

Model IR100 Universal Infrared Gas Analyzer

FEATURES

- Two models: simultaneous dual-gas (CO and CO₂) measurement model and single-gas dual-range measurement model
- Stable operation over the long term
- Less influence due to interfering gas
- Easy maintenance
- Wide variety of functions: self-diagnosis, simple calibration, automatic calibration, remote switching of measuring range, and range identification

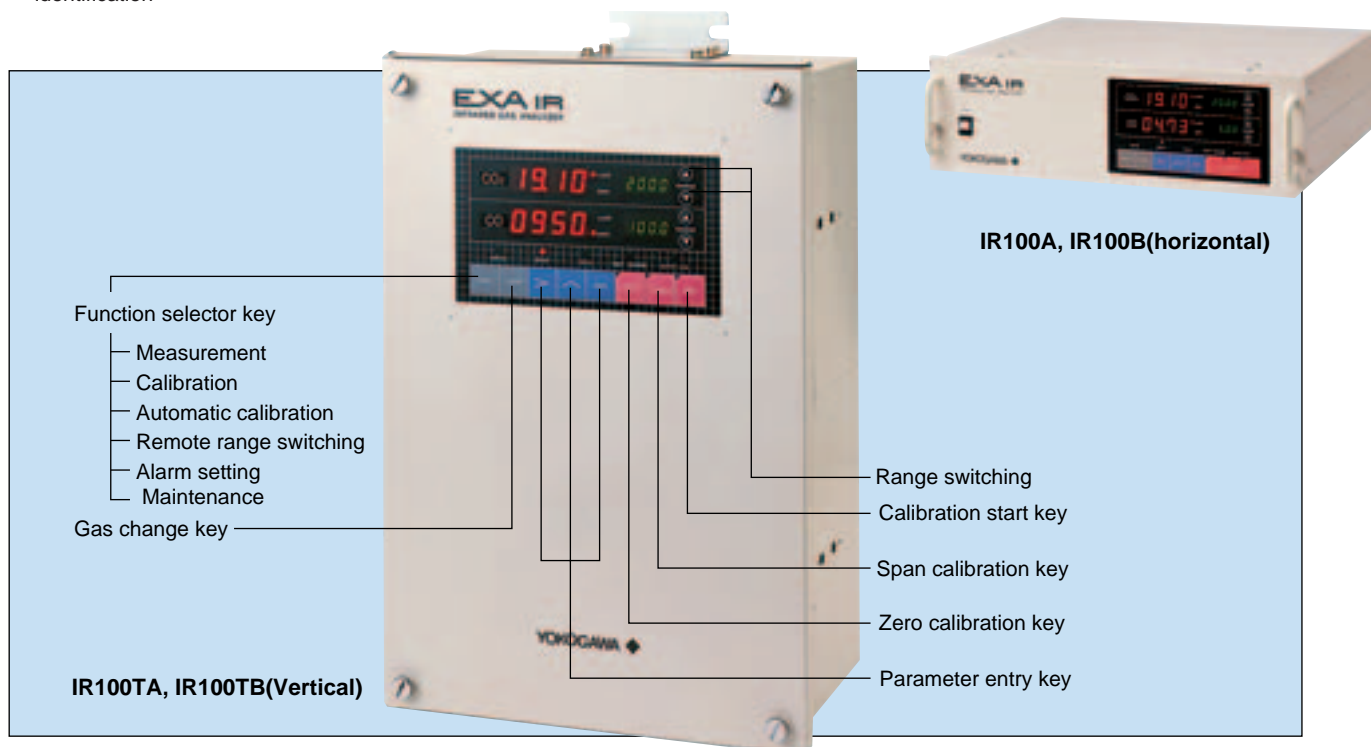

SPECIFICATIONS

- Models:
 - Single-gas dual-range measurement model, IR100TA(vertical model), IR100A(horizontal model)
 - Dual-gas measurement model IR100TB(vertical model), IR100B(horizontal model)
 - Operating principle: Infrared absorption (single beam)
 - Construction: Panel-mounted
 - Measured gases and measuring ranges:
 - IR100TA, IR100A (single-gas measurement)
 - CO₂: 0-500 ppm to 0-100%, CO: 0-500 ppm to 0-100%, CH₄: 0-1000 ppm to 0-100%
 - IR100TB, IR100B (simultaneous measurement of CO₂ and CO):
 - CO₂: 0-500 ppm to 0-100%, CO: 0-500 ppm to 0-100%
 - Repeatability: $\pm 0.5\%$ of FS for the primary range and $\pm 1\%$ of FS for the secondary range
 - Zero drift: $\pm 2\%$ of FS/week
 - Span drift: $\pm 2\%$ of FS/week
 - Response time (90% response): 15 seconds or less including the time required for substitution of the sample cell
 - Influence of interference gas: With 1000 ppm of CO, Reading of CO₂ ≤ 5 ppm, Reading of CH₄ ≤ 10 ppm
 - Sample gas condition: Flow rate 0.5 to 1 l/min, Pressure 500 Pa, Temperature 0 to 50°C
 - Ambient temperature: -5 to 45°C
 - Maximum allowable corrosive gases: NO_x: 1000 ppm, SO₂: 1000 ppm, HCl : 1 ppm, Others: none
 - Self-diagnosis: Corresponding error code is displayed for an abnormality.
 - Contact materials with gas:
 - Connection Japanese Industrial Standard (JIS) SUS314 stainless steel
 - Cell Gold or JIS SUS304 stainless steel
 - O-ring Neoprene
 - Output signals: Output 1 0 to 1 V DC, non-insulated, linearized signal, Output 2 4 to 20 mA DC, non-insulated, linearized signal
 - Dimensions (Panel mounting): IR100TA, IR100TB : 294 × 440 × 178 mm
IR100A, IR100B : 443 × 133 × 448 mm
 - Power supply: 100/115/220 V AC $\pm 10\%$, 50/60 Hz
- Refer to the GS11G2L1-01E for detailed specification

OPERATING PRINCIPLE

The single-beam method offers the following advantages:

1. The simple configuration simplifies handling and maintenance; and
2. The thermal flow sensor built into the detector is a hot-wire grid, and hence there are no moving parts. The temperature compensation (by a temperature sensor that should be installed near the detector) reduces the drift due to changes of ambient temperature. These features ensure superb stability for many years.

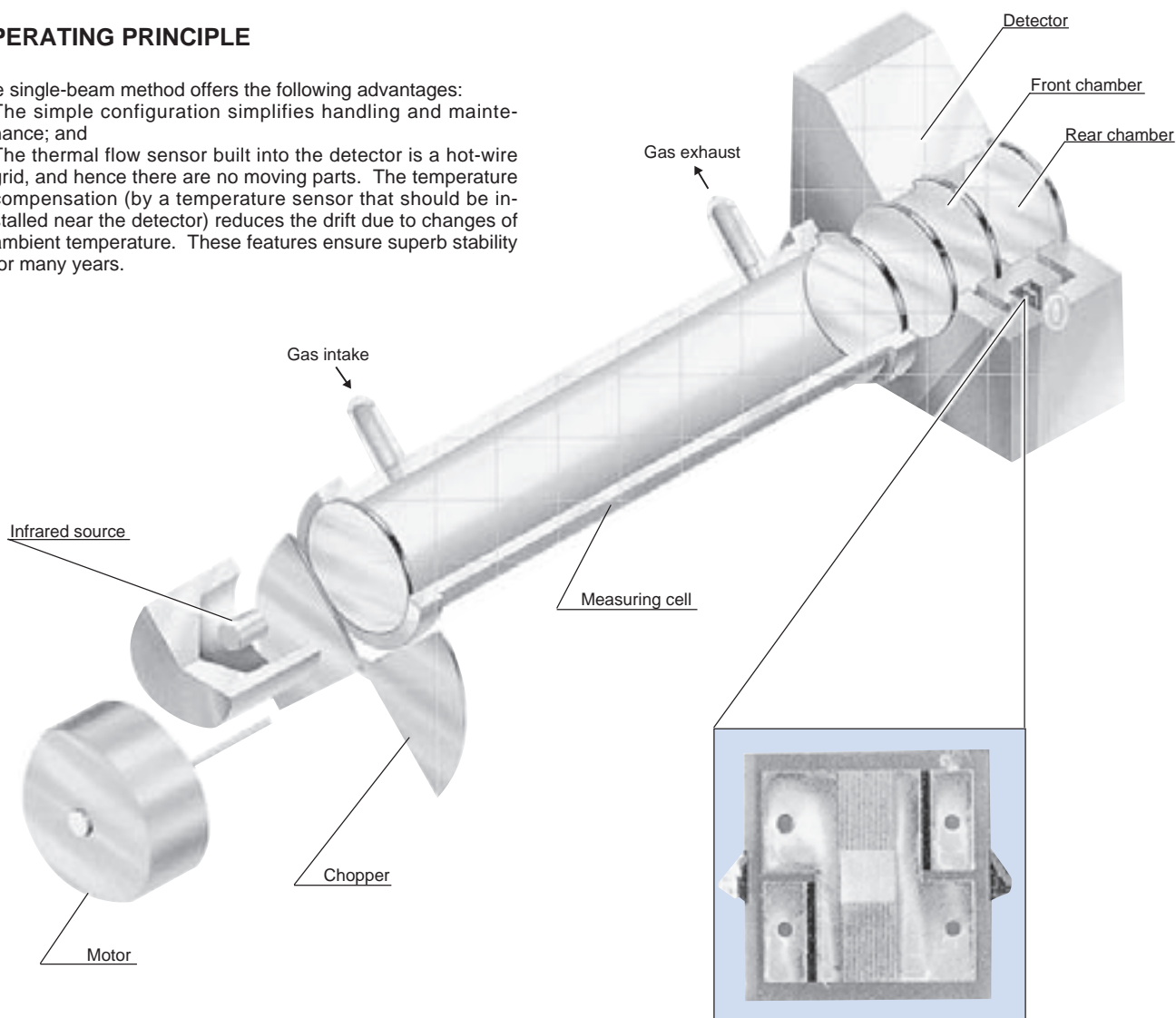

APPLICATIONS

- Blast furnace
- Converter
- Electric furnace
- Coke oven
- Cement kiln
- Coal kiln
- Carbonizing furnace
- Transforming furnace
- Underground motor pool
- Air-conditioning
- Green-house

CO: 0-40/0-50%, CO₂: 0-30/0-40%
 CO: 0-100%, CO₂: 0-100%
 CO: 0-100%, CO₂: 0-100%
 CO: 0-100%, CO₂: 0-100%
 CO: 0-1/0-5%
 CO: 0-1/0-5%
 CO₂: 0-1/0-2%
 CO₂: 0-0.5/0-1%

Thermal Flow Sensor

- Detects as a resistance value the flow of gas generated by the difference of the absorbed energy between the front chamber and rear chamber. From the change of this resistance, the concentration of the measured gas is calculated using Lambert-Beer's law.

YOKOGAWA

YOKOGAWA ELECTRIC CORPORATION

World Headquarters

9-32, Nakacho 2-chome, Musashino-shi,
Tokyo 180-8750, JAPAN
Tel.: +81-422-52-5617 Fax.: +81-422-52-3421

World Sales Headquarters

9-32, Nakacho 2-chome, Musashino-shi,
Tokyo 180-8750, JAPAN
Tel.: +81-422-52-6339 Fax.: +81-422-52-6552

YOKOGAWA ELECTRIC ASIA PTE. LTD.

5 Bedok South Road, Singapore 469270.
Tel.: (65)2419933 Fax.: (65)2419919

YOKOGAWA EUROPE B.V.

P.O.Box 163,3800 AD Amersfoort,
Vanadiumweg 11, 3812 PX Amersfoort,
THE NETHERLANDS
Tel.: +31-33-4-641611 Fax.: +31-33-4-641610

YOKOGAWA CORPORATION OF AMERICA

2 Dart Road
Newnan, GA 30265-1040, U.S.A.
Tel.: +1-770-254-0400 Fax.: +1-770-254-0928

YOKOGAWA AMERICA DO SUL S.A.

Avenida Jurua, 149 Alphaville CEP 06455-010 Barueri
Sao Paulo BRAZIL
Tel.: +55-11-7295-6282 Fax.: +55-11-421-3538

Represented by: