



**Model EXAxt AV550G
HART Protocol**

IM 11M12D01-51E

vigilantplant.™

Introduction

This is the HART Communicator manual for the EXAxt series of Model AV550G. This manual is described under the HART equipment that is ready to operate.

When using the HART Protocol for the EXAxt AV550G, please refer to the following instruction manuals.

◆ Special descriptions in this manual

This manual describes the products and instruction manuals listed below.

Products

AV550G: Averaging converter

Instruction manual

AV550G Instruction Manual: IM 11M12D01-01E

◆ Drawings in this manual

Drawings in this manual may be emphasized, abbreviated or partially omitted for easier explanation.

Screen images in this instruction manual are drawings to give you an idea of functions and operation; they may be slightly different from actual screen displays.

◆ Other items

The contents of this manual are subject to change without prior notice.

◆ After-sales Warranty

- Do not modify the product.
- During the warranty period, for repair under warranty carry or send the product to the local sales representative or service office. Yokogawa will replace or repair any damaged parts and return the product to you.
- Before returning a product for repair under warranty, provide us with the model name and serial number and a description of the problem. Any diagrams or data explaining the problem would also be appreciated.
- If we replace the product with a new one, we won't provide you with a repair report.
- Yokogawa warrants the product for the period stated in the pre-purchase quotation. Yokogawa shall conduct defined warranty service based on its standard. When the customer site is located outside of the service area, a fee for dispatching the maintenance engineer will be charged to the customer.
- In the following cases, customer will be charged repair fee regardless of warranty period.
 - Failure of components which are out of scope of warranty stated in instruction manual.
 - Failure caused by usage of software, hardware or auxiliary equipment, which Yokogawa Electric did not supply.
 - Failure due to improper or insufficient maintenance by user.
 - Failure due to modification, misuse or outside-of-specifications operation which Yokogawa does not authorize.
 - Failure due to power supply (voltage, frequency) being outside specifications or abnormal.
 - Failure caused by any usage out of scope of recommended usage.
 - Any damage from fire, earthquake, storms and floods, lightning, disturbances, riots, warfare, radiation and other natural changes.
- Yokogawa does not warrant conformance with the specific application at the user site. Yokogawa will not bear direct/indirect responsibility for damage due to a specific application.
- Yokogawa Electric will not bear responsibility when the user configures the product into systems or resells the product.
- Maintenance service and supplying repair parts will be covered for five years after the production ends. For repair for this product, please contact the nearest sales office described in this instruction manual.

Contents

Introduction	i
◆ Special descriptions in this manual	i
◆ Drawings in this manual	i
◆ Other items	i
◆ After-sales Warranty	ii
1. Operation via HART Communicator	1-1
1.1 Conditions of Communication Line	1-1
1.1.1 Interconnection between AV550G and HART Communicator	1-1
1.1.2 Communication Line Requirements	1-1
2. Basic Operation of the HART Communicator (Model 275)	2-1
2.1 Keys and Functions	2-1
2.2 Display	2-2
2.3 Calling Up Menu Addresses	2-3
2.4 Entering, Setting and Sending Data	2-5
3. Parameters	3-1
3.1 Menu Tree	3-1
3.2 Setting Parameters	3-7
3.2.1 Burst Mode	3-7
3.2.2 Multidrop Mode	3-8
3.2.3 Write Protection	3-10
3.3 Calibration	3-14
3.4 Indication Check	3-15
3.5 Blow Back	3-16
3.6 Self-Diagnostics	3-17
3.6.1 Control Card Self-Diagnostics	3-17
3.6.2 Channel Card Self-Diagnostics	3-18
3.7 Status Check	3-20
4. Maintenance	4-1
Revision Record	i

1. Operation via HART Communicator

1.1 Conditions of Communication Line

1.1.1 Interconnection between AV550G and HART Communicator

The HART Communicator can interface with the AV550G from the control room, the AV550G site, or any other wiring termination point in the loop, provided there is a minimum load resistance of 250Ω between the connection and the receiving instrument. To communicate, it must be connected in parallel with the AV550G, the connections are non-polarized. Figure 1.1 illustrates the wiring connections for direct interface at the AV550G site. The HART Communicator can be used for remote access from any terminal strip as well.

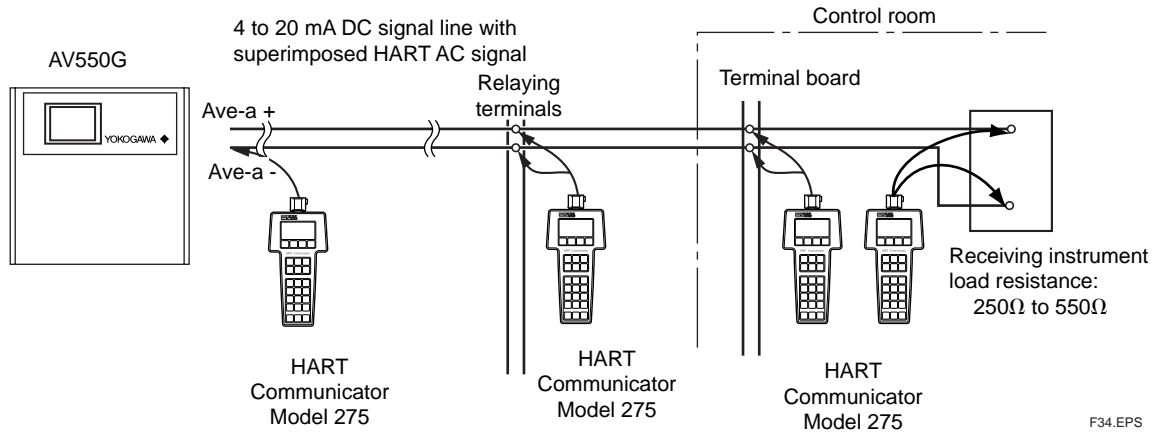

Figure 1.1 Interconnection Diagram

1.1.2 Communication Line Requirements

Specifications for Communication Line:

- Load resistance: 250 to 550Ω (including cable resistance)
When multidrop mode, see Figure 1.2.
- Minimum cable size: 24 AWG, (0.51 mm diameter)
- Cable type: Single pair shielded or multiple pair with overall shield
- Maximum twisted-pair length: 2,000 m
- Maximum multiple twisted-pair length: 1,000 m
- Use the following formula to determine cable length for a specific application;

$$L = \frac{65 \times 10^6}{(R \times C)} - \frac{(C_i + 10,000)}{C}$$

- where: L = length in feet or meters
- R = resistance in ohms, current sense resistance
- C = cable capacitance in pF/ft or pF/m
- C_i = 50,000 pF

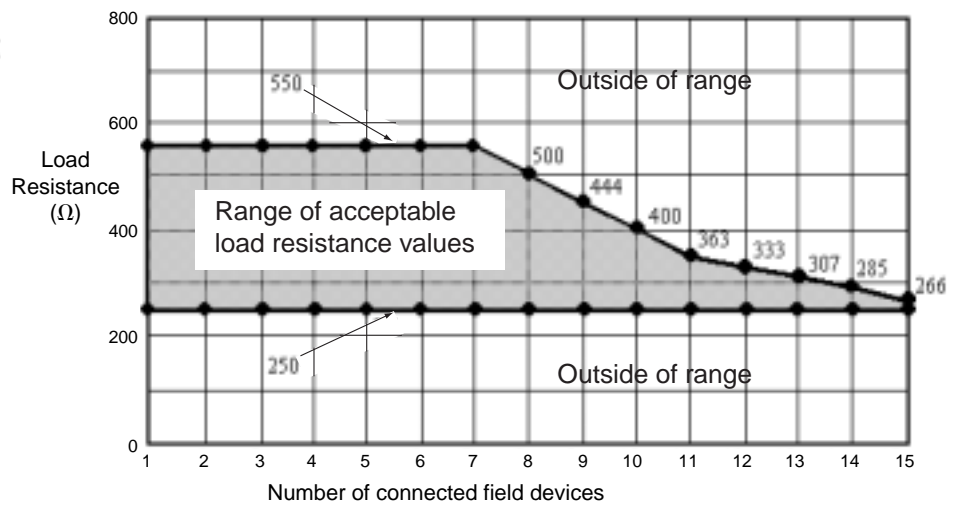

F010201.EPS

Figure 1.2 Load Resistance and Number of Devices in Multidrop Mode

2. Basic Operation of the HART Communicator (Model 275)

2.1 Keys and Functions

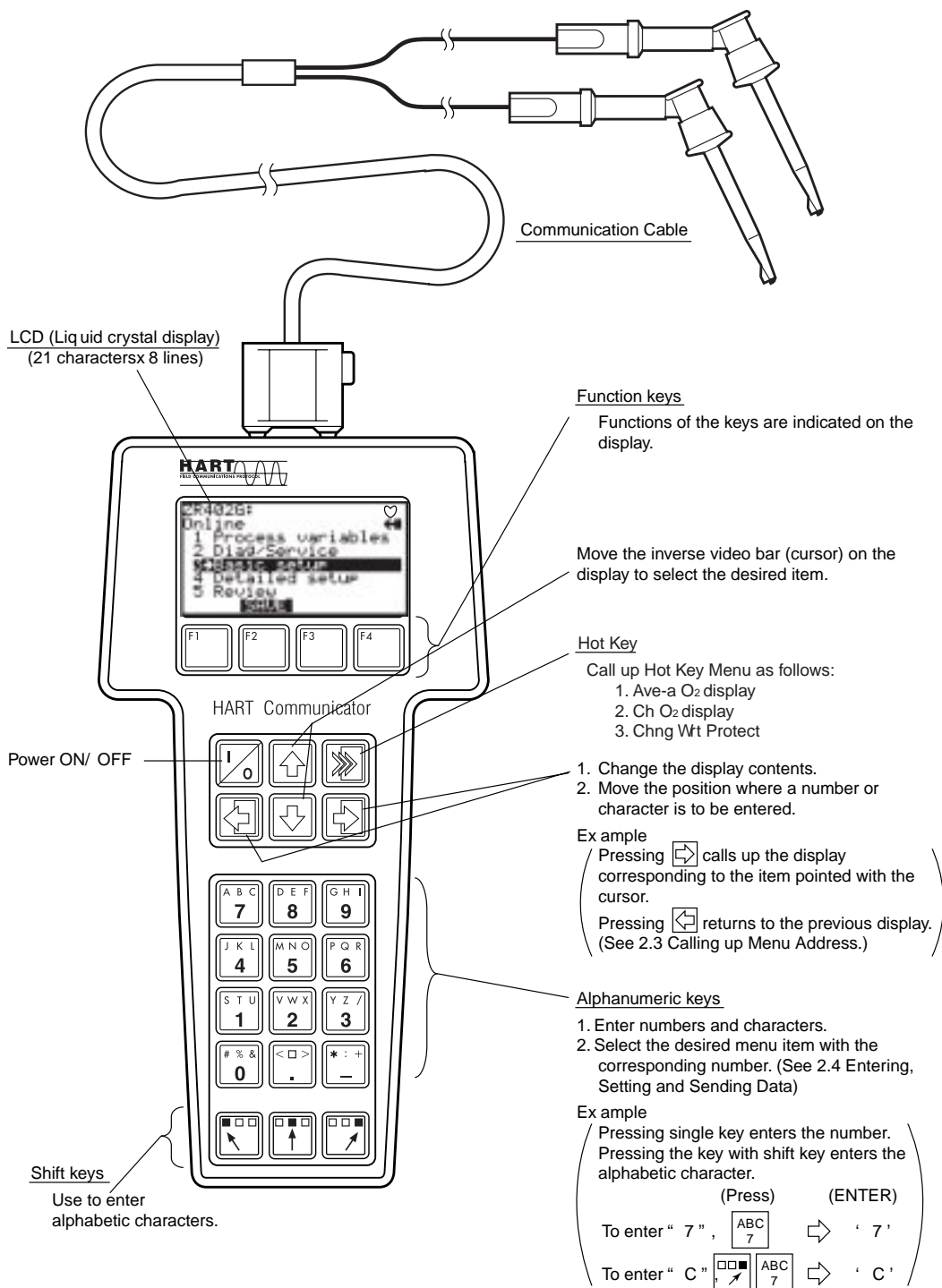

F020101.EPS

Figure 2.1 HART Communicator

2.2 Display

The HART Communicator automatically searches for AV550G on the 4 to 20 mA loop when it is turned on. When the HART Communicator is connected to a AV550G, it displays “**Online**” menu as shown below.

(If AV550G is not found, the communicator displays the message “No Device Found. Press OK....” Press the OK ‘F4’ function key and the main menu appears. Please retry after confirming the connection with the AV550.)

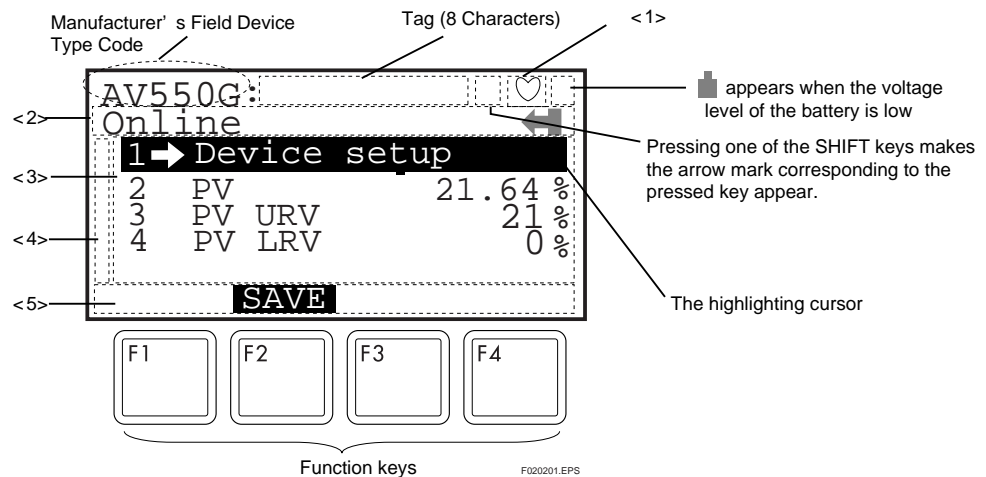

Figure 2.2 Display

- <1> ♥ appears and flashes during communication between the HART Communicator and the AV550G. In Burst mode*, ♥ appears.
- <2> The current display menu title appears.
- <3> Each item in menu of <2> appears.
- <4> ↓ and/or ↑ appear when the items are scrolled out of the display.
- <5> On any given menu, the label appearing above a function key indicates the function of that key in the current menu.

Note: (*) Refer to “3.2.1 Setting Parameters Burst Mode”.

Function Key Labels

F1	F2	F3	F4
HELP access on-line help	ON/OFF activates or deactivates a binary variable	ABORT terminate current task	OK acknowledge information on screen
RETRY try to re-establish communication	DEL delete current character or Hot Key Menu item	ESC leave value unchanged	ENTER accept user-entered data
EXIT leave the current menu	SEND send data to device, or mark data to send	QUIT terminate session because of a communication error	NEXT leave the current menu
YES answer to yes/ no question	PGUP move up one help screen	PGDN move down one help screen	NO answer to yes/ no question
ALL include current Hot Key item on Hot Key Menu for all devices	PREV go to previous message in a list of messages	NEXT go to next message in the list of messages	SKIP do not mark variable to be sent in off-line configuration
SAVE save information to communicator	EDIT edit a variable value	HOME go to the top menu in the device description	ONE include Hot Key item for one device
SEND send data to device, or mark data to send	ADD add current item to Hot Key Menu	BACK go back to menu from which HOME was pressed	

F0204.EPS



2.3 Calling Up Menu Addresses

3.1 Menu Tree shows the configuration of Online Menu which is needed for the operation with HART Communicator. The desired item can be displayed with ease by understanding the menu configuration.

When the HART Communicator is connected to the AV550G, “**Online**” menu will be displayed after the power is turned on (See Figure 2.2). Call up the desired item as follows:

Key operation

There are two ways to select a desired menu item.

1. Use the  or  key to select the desired item, and then press the  key.
2. Press the number key corresponding to the desired item.

- To return to the previous display, press the  key,

If **EXIT**, **ESC** and **ABORT** are displayed, press the desired function Key.

Example: Call up the “**Tag**” to change the tag number.

Check where “**Tag**” is located in the menu tree. Then, call up “**Tag**” on the display according to the menu tree.

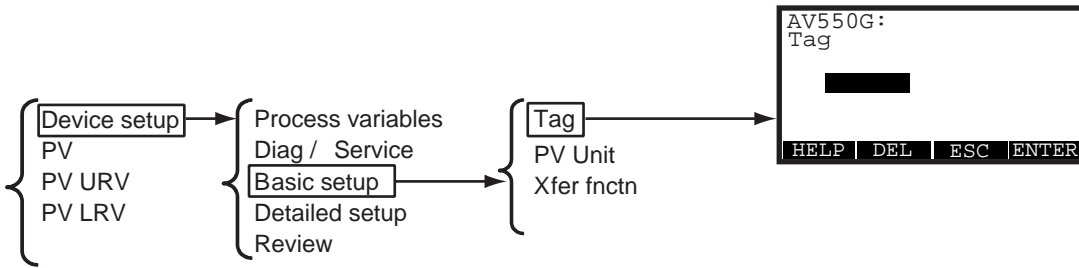

F020301.EPS

- | | Display | Operation | |
|---|--|---------------|--|
| 1 | AV550G:
Online
1 → Device setup
2 PV 21.64 %
3 PV URV 21 %
4 PV LRV 0 %
[SAVE] | or | Display 1 at left appears when the HART communicator is turned on. Select " Device set up " |
| 2 | AV550G:
Device setup
1 Process variables
2 Diag/Service
3 → Basic setup
4 Detailed setup
5 Review
[SAVE] [HOME] | x 2
or
 | Select " Basic setup ". |
| 3 | AV550G:
Basic setup
1 → Tag
2 PV Unit
3 Xfer fnctn Linear
[HELP] [SAVE] [HOME] | or | Select " Tag ". |
| 4 | AV550G:
Tag
[HELP] [DEL] [ESC] [ENTER] | | The display for Tag setting appears. (The default value of "Tag" is blank.) |

F020302.EPS

2.4 Entering, Setting and Sending Data

The data, which are entered with the keys, are set in the HART Communicator by pressing **ENTER (F4)**. Then, by pressing **SEND (F2)**, the data are sent to the AV550G. Note that the data are not set in the AV550G if **SEND (F2)** is not pressed. All the data set with the HART Communicator are held in memory unless power is turned off, so all data can be sent to the AV550G in one burst.

Operation

Entering data on the “**Tag**” setting display.

On alphabetic characters, only capital letters can be used for setting Tag No. with HART Communicator.

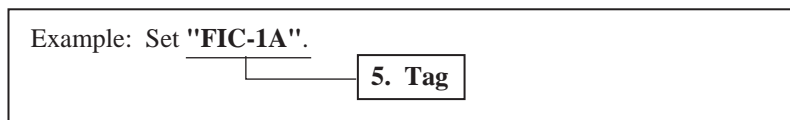

F020401.EPS

Call up "Tag" setting display.

1. Device setup ---> 3.basic setup ---> 5.Tag



On the setting display shown above, enter the data as follows:

Character to be entered	Operation	Display
F	DEF 8	F ██████████
I	GHI 9	F I ██████████
C	ABC 7	F I C ██████████
-	*: + —	F I C - ██████████
1	STU 1	F I C - 1 ██████████
A	ABC 7	F I C - 1 A ██████████

F020403.EPS

Display

1

```
AV550G:
Tag
  FIC-1A
HELP DEL ESC ENTER
```

2

```
AV550G:
Basic setup ←
1→Tag FIC-1A
2 PV Unit %
3 Xfer fnctn Linear
HELP SEND HOME
```

3

```
AV550G:FIC-1A
Basic setup ←
1→Tag FIC-1A
2 PV Unit %
3 Xfer fnctn Linear
HELP SAVE HOME
```

Operation



(ENTER)

Press **ENTER (F4)** to set the data in the HART Communicator after entering the data.



(SEND)

Press **SEND (F2)** to send the data to the AV550G.

♡ is flashing during communication.

SEND label changed to **SAVE** label, and the transmission is completed.

Press **HOME (F3)**, and return "Online Menu".

F020404.EPS

3. Parameters

3.1 Menu Tree

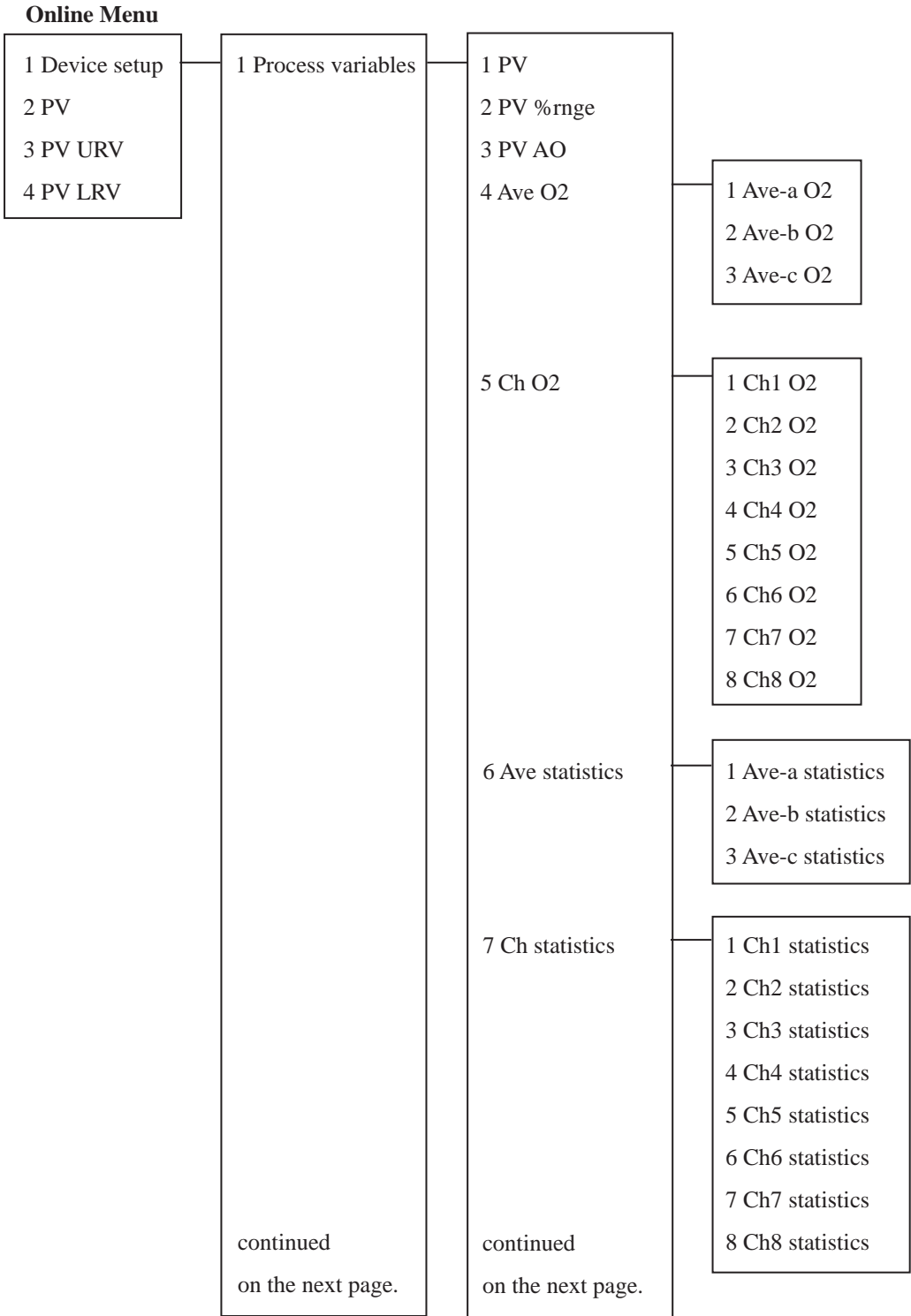

Online Menu

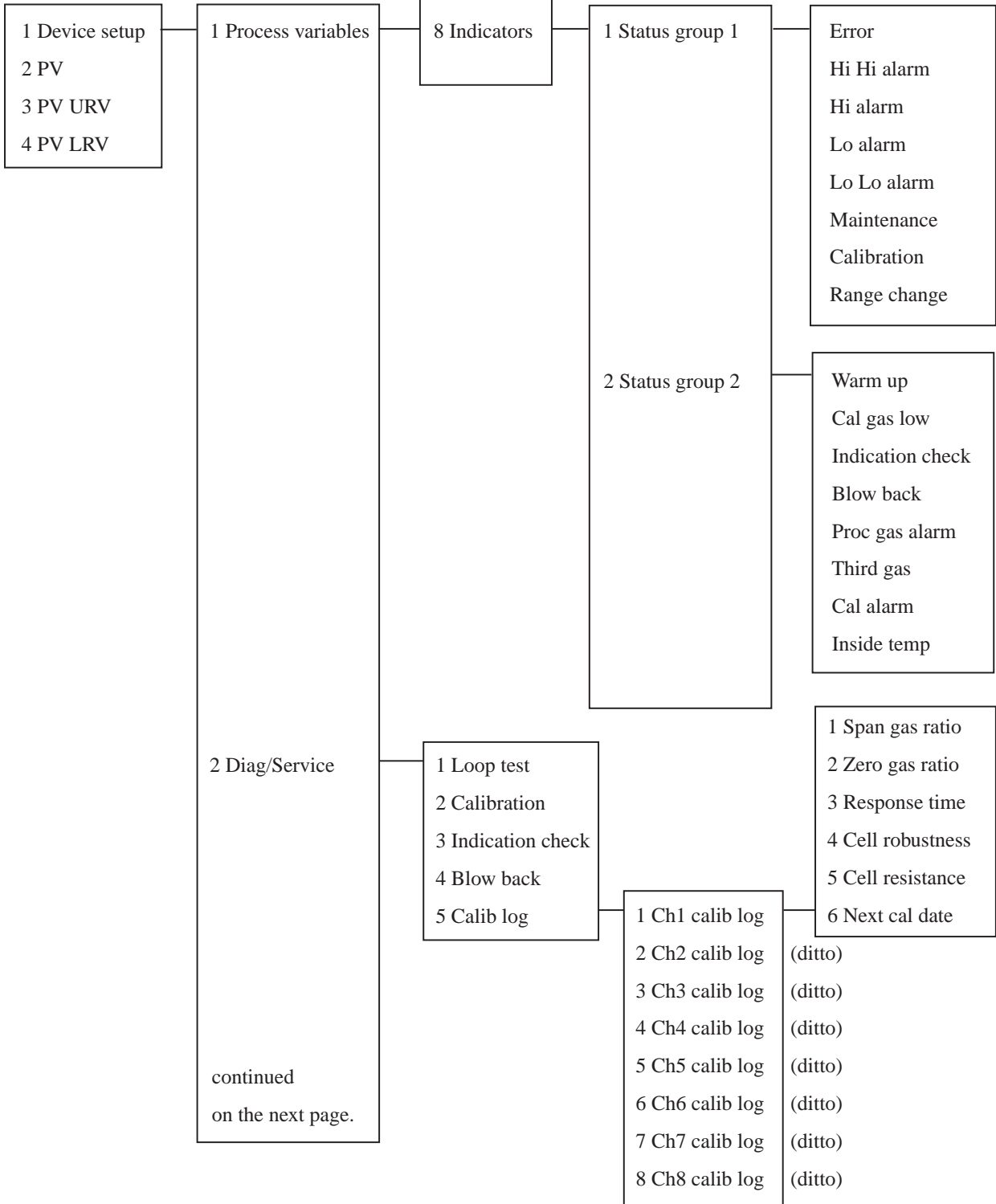

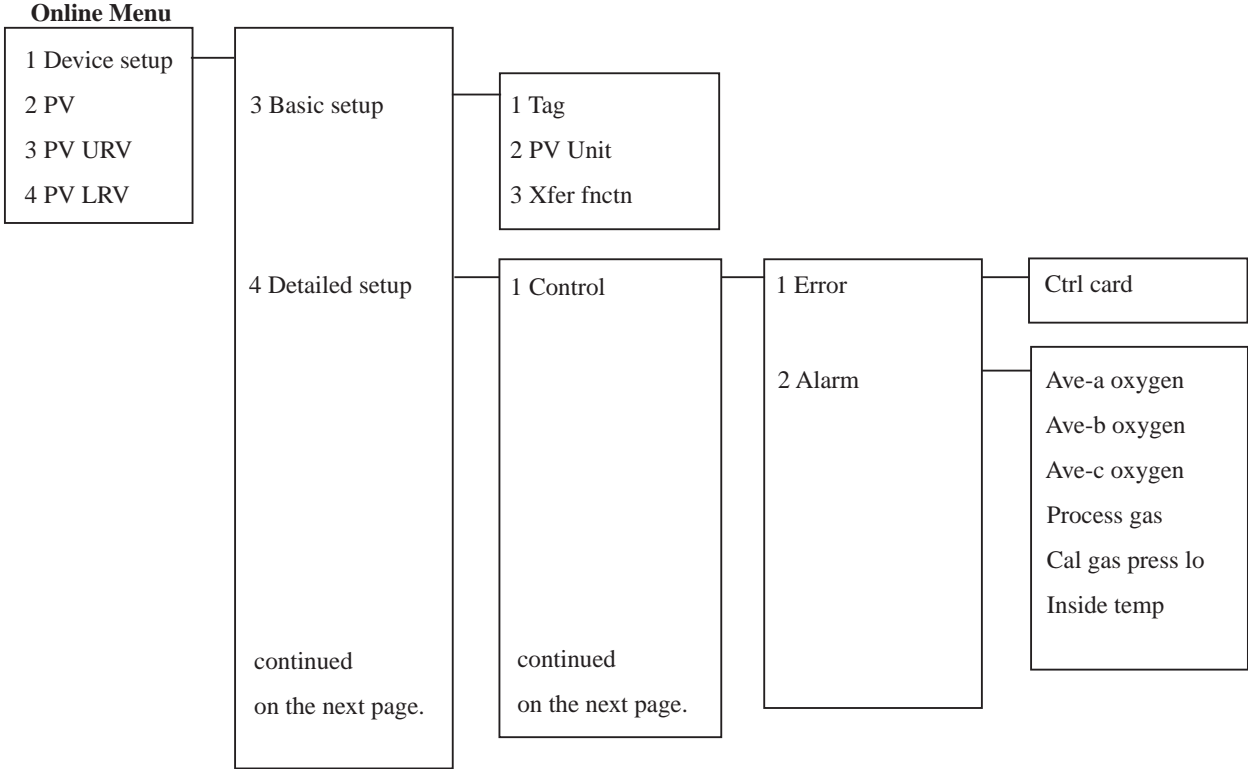

Online Menu

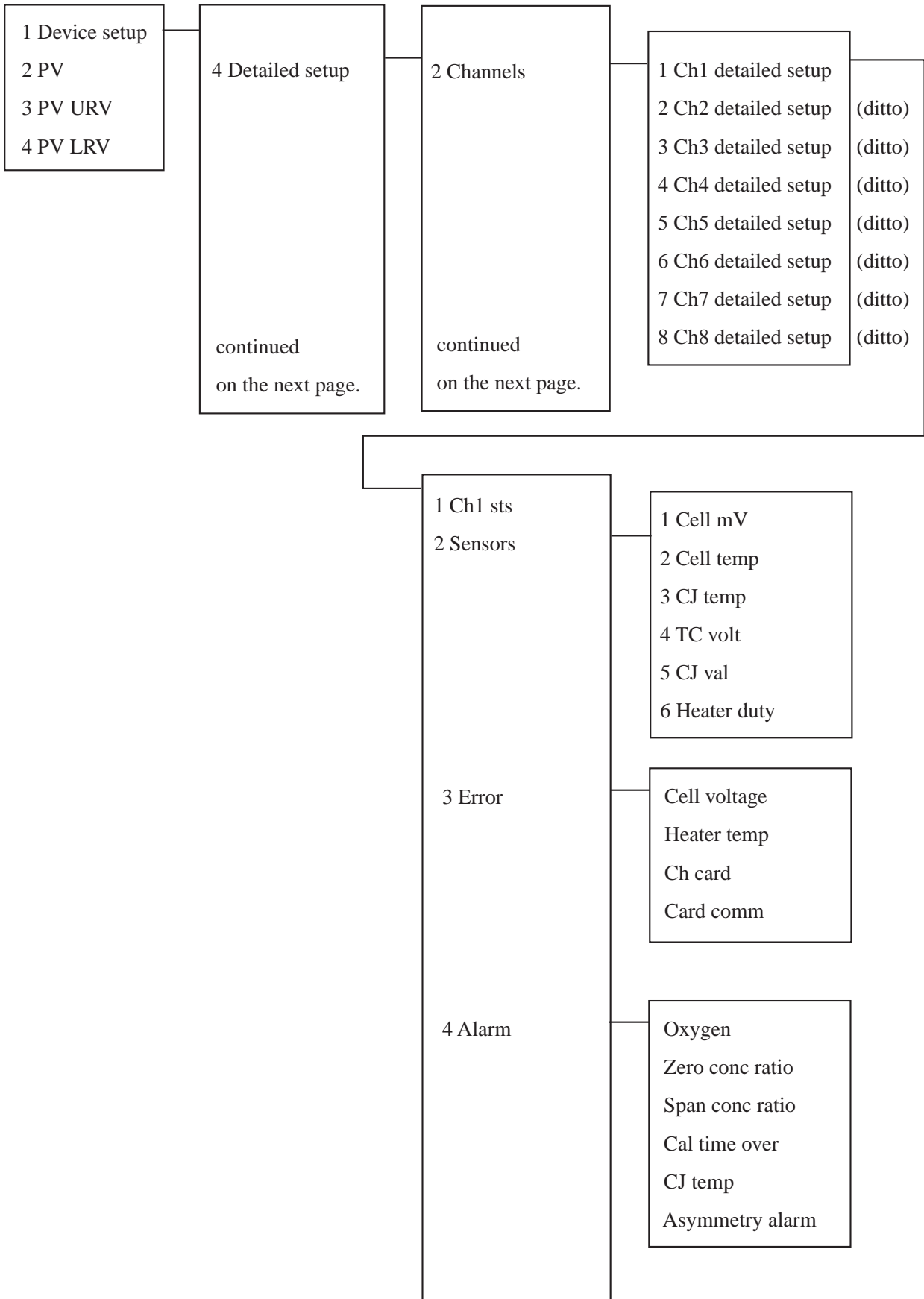

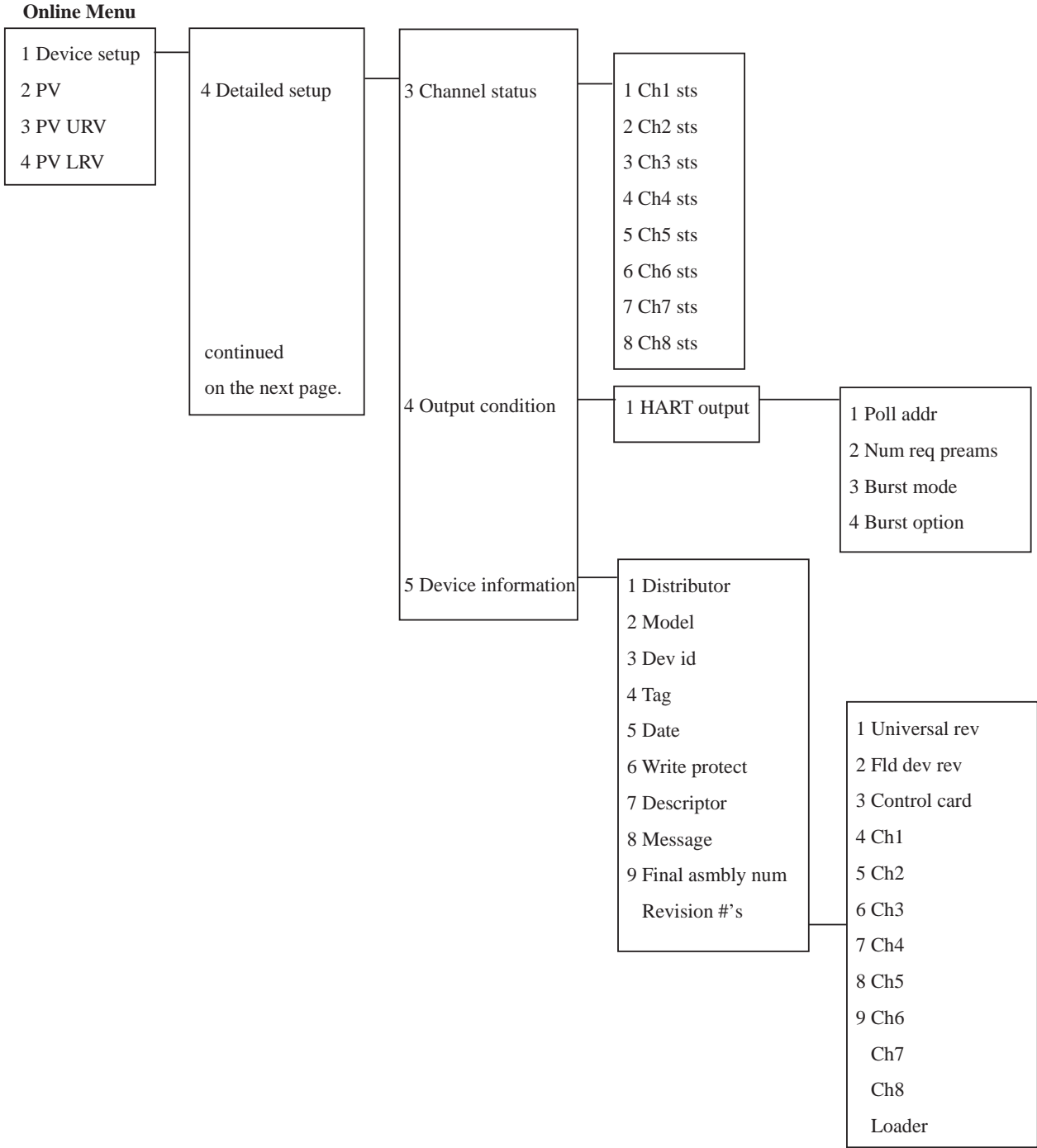

Online Menu

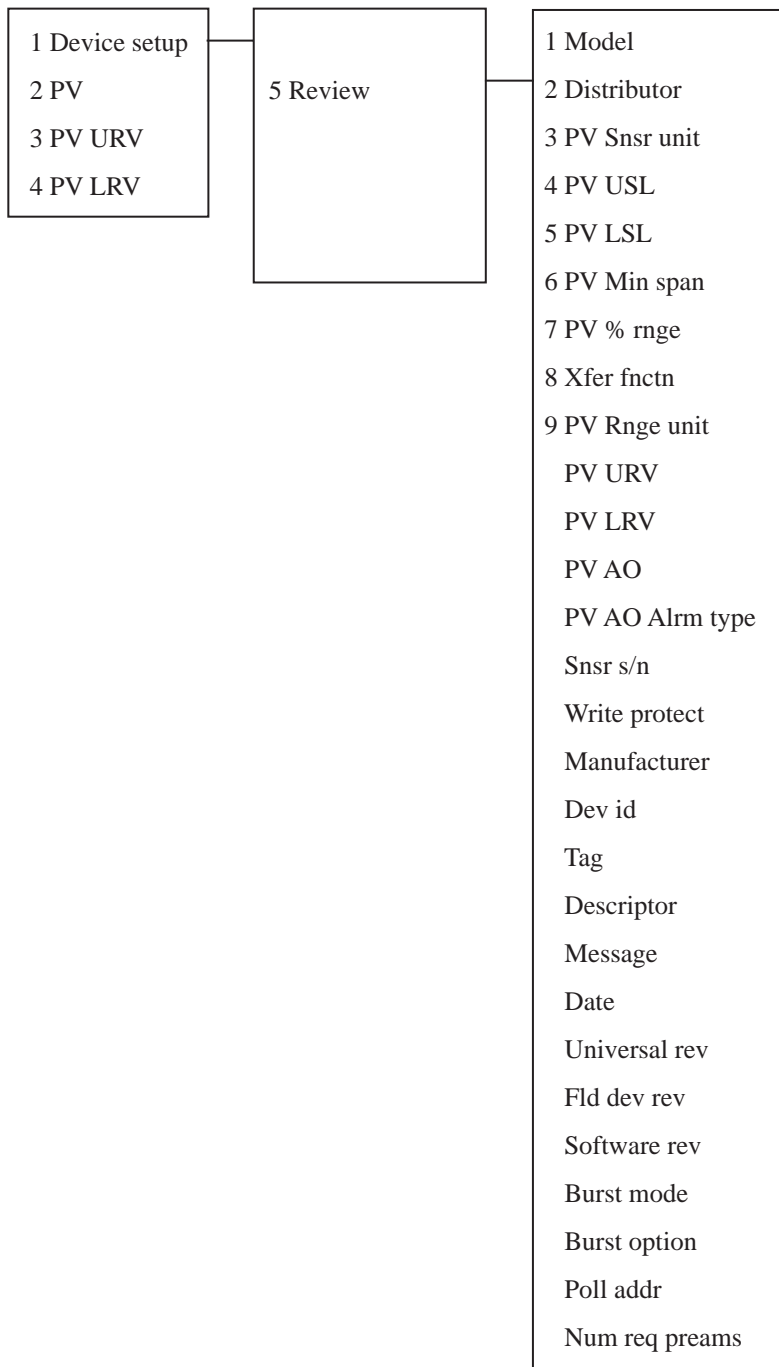

3.2 Setting Parameters

3.2.1 Burst Mode

The AV550G continuously sends the data stored in it when burst mode is set "On". Either one of measured value, % output value, or 4 to 20 mA output value can be selected and sent. The data is sent periodically at 75 ms intervals as a digital signal when the AV550G is set in burst mode. Therefore, communication by the HART simultaneous communicator is also possible.

Setting of Burst Mode



Call up "Burst option" display.

1.Device setup ---> 4.Detailed setup ---> 4.Output condition ---> 1.HART output ---> 4.Burst option

Display	Operation	
<pre>AV550G: Burst option ***** PV % range/current Process vars/crnt HELP ESC ENTER</pre>	 (ENTER)	Set data to be sent. <ul style="list-style-type: none"> ● Measured value (PV) ● % output value (% range/current) ● 4 to 20 mA output value (Process vars /crnt)

Call up "Burst mode" display.

3.HART output → 3.Burst mode

1	<pre>AV550G: Burst mode Off off on ESC ENTER</pre>	  (ENTER)	Set "On" and press ENTER (F4) .
2	<pre>AV550G: HART output 1 Poll addr 0 2 Num req preams 5 3→Burst mode On 4 Burst option PV HELP SEND HOME</pre>	 (SEND)	Press SEND (F2) .

F030209.EPS

3.2.2 Multi drop Mode

Field devices in multidrop mode refer to the connection of several field devices on a single communication line. Up to 15 field devices can be connected when set in multidrop mode. To activate multidrop communication, each field device address must be changed to a unique number in the range 1 to 15. This change deactivates the 4 to 20mA output and changes it to 4mA.

Setting of Multi drop Mode

Call up "Poll addr" display.

1.Device setup ---> 4.Detailed setup ---> 4.Output condition ---> 1.HART output ---> 1.Poll addr

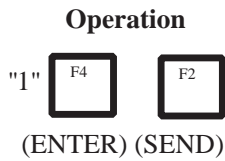
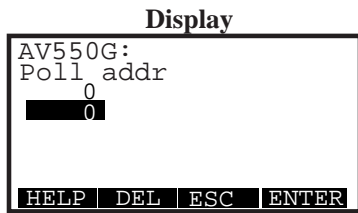

Set the polling address (a number from 1 to 15) and press **ENTER (F4)**. Then Press **SEND (F2)**.

F030210.EPS

Call up "Auto Poll" display.

HART output ---> Online Menu ---> Main Menu ---> 4.Utility ---> 1.Configure Communication ---> 1.Polling

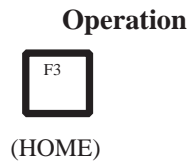
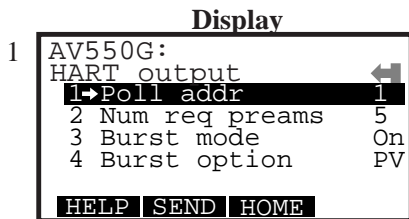

Return "Online Menu" with **HOME (F3)**.

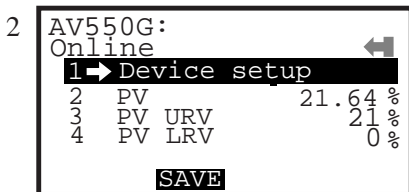

Return to "Main Menu" with a "previous" key.

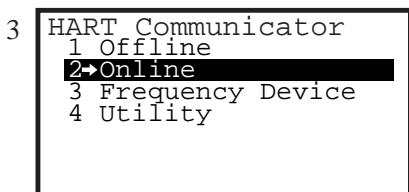

Select "Utility".

F030211.EPS

4

```

HART Communicator
Utility
1->Configure Communic
2 System Information
3 Listen for PC
4 Storage Location
↓5 Simulation
    
```

 Select "Configure Communication".

5

```



HART Communicator
Configure Communica
1->Polling
2 Contrast
3 Off Time
4 Ignore diagnostics
5 Delete Configs
HELP
    
```

 Select "Polling".

6

```

HART Communicator
Polling
Ask Before Polling
Never Poll
Ask Before Polling
Always poll
Digital poll
HELP ESC ENTER
    
```

 ×3  Select "Digital Poll" and press ENTER (F4).

(ENTER)

F030212.EPS

 **NOTE**

1. If "Polling" is set to "Never Poll" after the address is set, "Online Menu" cannot be called up and displayed. Be sure to set "Polling" to "Digital Poll" after setting the polling address.
2. When the same polling address is set for two or more field devices in multidrop mode, communication with those field devices is disabled.

Example: Communication when set in the multidrop mode.

Display

1

```

HART Communicator
Online
1->1: ZIA-01A
2 2: ZIA-02A
    
```

2

```

AV550G:ZIR-01A
Online
1->Device setup
2 PV 21.64 %
3 PV URV 21 %
4 PV LRV 0 %
SAVE BACK
    
```

3

```

HART Communicator
1 Offline
2->Online
3 Frequency Device
4 Utility
    
```

Operation

- (1) The HART Communicator searches for field devices is set in multidrop mode when the HART Communicator is turned on. When a HART Communicator is connected to a field device, its tag will be displayed (display 1).
- (2) Select desired field device. After that, normal communication with the selected field device is possible. However, the communication speed is slow in this case (display 2).
- (3) To communicate with another field device, call up display 3, and select "Online".
- (4) Display1 will appear. Repeat the above operation.

F030213.EPS

Releasing from Multidrop Mode

First, call up the "Poll addr" display, and set the address to 0.
 Second, call up the "Polling" display, and set "Never Poll".

 NOTE	If the above releasing method is carried out in the reverse order "Online Menu" can not be called up.
---	---

3.2.3 Software Write Protect







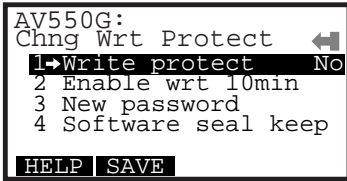

AV550G configured data is saved by the write protect function. Write protect status is set to YES when 8 alphanumeric characters are entered in the New password field and transferred to the AV550G. In write protect YES status, the averaging converter AV550G does not accept parameter changes. When the 8 alphanumeric string entered in the New password field is also entered in the Enable write field and transferred to the averaging converter, it will be possible to change averaging converter parameters during a 10 minute period.

To change the averaging converter from write protect YES status back to write protect NO status, enter 8 spaces in the New password field after write protect has been released using enable write.

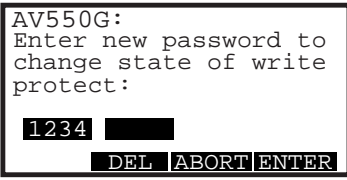
Setting Password

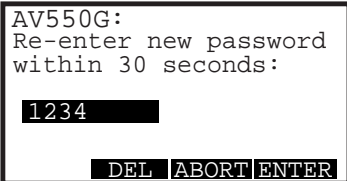
Example: Set the password to 1234

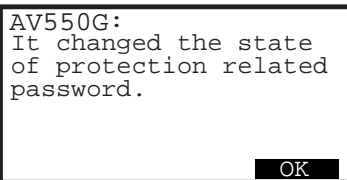
Call up "Chng Wrt protect" display.
 Hot key ---> 3.chng Wrt protect

Display	Operation	
1 		Select the "New password".
2 	'1 2 3 4'  (ENTER)	Set "1234" and press ENTER (F4) .
3 	"1 2 3 4"  (ENTER)	Reenter "1234" and press ENTER (F4) within 30 seconds.
4 	 (OK)	

F030215.EPS

5 AV550G:
Chng wrt Protect ←
1 Write protect Yes
2 Enable wrt 10min
3 → New password
4 Software seal keep
SAVE







F030216.EPS

Changing Password

Example: To change the password from 1234 to 6789A

Call up "Chng Wrt protect" display.

Hot key ---> 3.chng Wrt protect

	Display	Operation	
1	<pre> AV550G: Chng wrt Protect ← 1 Write protect Yes 2→Enable wrt 10min 3 New password 4 Software seal keep SAVE </pre>		Select the "Enable wrt 10min".
2	<pre> AV550G: Enter current password to enable to write for 10 minutes: 1234 DEL ABORT ENTER </pre>	'1 2 3 4'  (ENTER)	Set the old password "1234" and press ENTER (F4).
3	<pre> AV550G: Released the write protection for 10 minutes. ABORT OK </pre>	 (OK)	Press OK (F4).
4	<pre> AV550G: If you want to release completely, you have to change password to all of spaces. ABORT OK </pre>	 (OK)	Press OK (F4).
5	<pre> AV550G: Chng wrt Protect ← 1 Write protect No 2 Enable wrt 10min 3→New password 4 Software seal keep SAVE </pre>		Select the "New password".
6	<pre> AV550G: Enter new password to change state of write protect: 6789A DEL ABORT ENTER </pre>	"6789A"  (ENTER)	Set new password "6789A" and press ENTER (F4).
7	<pre> AV550G: Re-enter new password within 30 seconds: 6789A DEL ABORT ENTER </pre>	"6789A"  (ENTER)	Reenter new password "6789A" and press ENTER (F4).

F030218.EPS

8

AV550G:
It changed the state
of protection related
password.

OK



(OK)

Press **OK (F4)**.

F030219.EPS

**NOTE**

1. Enable Wrt 10 min releases write protect status for 10 minutes. While write protect status is released, enter a new password in the New Password field.
It will not be possible to set a new password when 10 minutes have elapsed.
2. To release write protect status completely, enter 8 spaces in the New Password field according to the instructions given in Changing the Password. This causes write protect status to change from YES to NO.

“Master password” and “Software Lock”

If you forget the password that has been registered, it is possible to release the mode for 10 minutes by using a master password. Enter YOKOGAWA to release Write protect status for 10 minutes. If this master password is used, the status shown in the parameter “Software seal” is changed from “Keep” to “Break” Press Hot key and select “3. Wrt Protect menu”. Current status is shown in “4 Software seal”. This status will be reverted from “Break” to “Keep” by registering a new password.

3.3 Calibration

Here we explain how to execute Semi-Auto Calibration using HART communications.

This requires the AV550G Calibration mode to have been set to Semi-Auto or Auto.

For further details, refer to “Section 9. Calibration” in the AV550G Instruction Manual.



NOTE

Calibration-related parameters can not be set remotely using HART communication.
 Calibration can not be canceled using HART communication.

Call up “Calibration” display.

1. Device setup ---> 2. Diag/Service ---> 3. Calibration

	Display	Operation	
1	AV550G: Select channel. 1 Ch1 2 Ch2 3 Ch3 4 Ch4 ↓ 5 Ch5 ABORT ENTER	<div style="border: 1px solid black; display: inline-block; padding: 2px 5px;">STU 1</div> <p>Select Channel to be calibrated (Ch.1 in this example).</p>	
2	AV550G: You select Ch1. Do you want to execute semi-auto calibration? ABORT ON	<div style="border: 1px solid black; display: inline-block; padding: 2px 5px;">F4</div> (OK) <p>Confirm that you want to execute calibration</p>	
3	AV550G: Diag/Service ← 1 Loop test 2→Calibration 3 Indication check 4 Blow back 5 Calib log HELP SAVE HOME	<p>Calibration is started using parameters (Cal. Time, Hold Time) set in the AV550G</p>	

F030301.EPS

3.4 Indication Check

Here we explain how to excute a Semi-Auto Indication Check using HART communications. This requires the AV550G Indication Check mode to have been set to Semi-Auto or Auto.

For further details, refer to “Section 10. Indication Check” in the AV550G Instruction Manual.

	<p>NOTE</p>	<p>Indication-Check-related parameters can not be set remotely using HART communication.</p> <p>Indication Check can not be canceled using HART communication.</p>
--	--------------------	--

Call up “Indication check” display.

- 1. Device setup ---> 2. Diag/Service ---> 3. Indication check

	Display	Operation	
1	<pre> AV550G: Select channel. 1 Ch1 2 Ch2 3 Ch3 4 Ch4 ↓5 Ch5 ABORT ENTER </pre>	<div style="border: 1px solid black; padding: 2px; display: inline-block;">STU 1</div>	<p>Select Channel for Indication Check (Ch.1 in this example).</p>
2	<pre> AV550G: You select Ch1. Do you want to execute semi-auto indication check? ABORT ON </pre>	<div style="border: 1px solid black; padding: 2px; display: inline-block;">F4 (OK)</div>	<p>Confirm that you want to execute Indication Check</p>
3	<pre> AV550G: Diag/Service ← 1 Loop test 2 Calibration 3→Indication check 4 Blow back 5 Calib log HELP SAVE HOME </pre>		<p>Indication Check is started using parameters (Check Time, Hold Time) set in the AV550G</p>

F030401.EPS

3.5 Blow Back

Here we explain how to execute a Semi-Auto Blow Back using HART communications. This requires the AV550G Blow Back mode to have been set to Semi-Auto or Auto.

For further details, refer to “Section 10.5 Blow Back” in the AV550G Instruction Manual.



NOTE

Blow-Back-related parameters can not be set remotely using HART communication.
Blow Back can not be canceled using HART communication.

Call up “Blow back” display.

1. Device setup ---> 2. Diag/Service ---> 4. Blow back

Display

1

```
AV550G:
Do you want to
execute blow back?

ABORT ON
```

Operation



(OK)

Confirm that you want to execute Blow Back

2

```
AV550G:
Diag/Service ←
1 Loop test
2 Calibration
3 Indication check
4 → Blow back
5 Calib log
HELP SAVE HOME
```

Blow Back is started using parameters (Blow Back Time, Hold Time) set in the AV550G

F030501.EPS









3.6 Self-Diagnostics

Here we explain how to check Error or Alarm messages from the AV550G using a HART Communicator. The table below shows the correspondence between error and alarm messages displayed on the HART Communicator and corresponding error and alarm messages in the AV550G. For more details about these error and alarm messages, and troubleshooting procedures, refer to “Section 12. Troubleshooting” in the AV550G Instruction Manual.

3.6.1 Control Card Self-Diagnostics

Call up “Detailed setup” display.

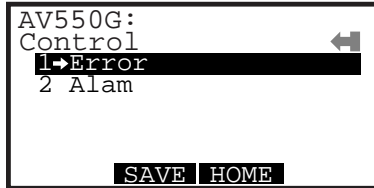
1. Device setup ---> 4. Detailed setup

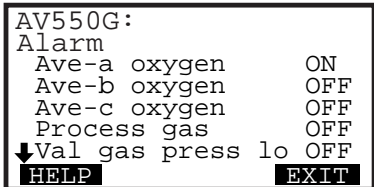



	Display	Operation	
1			Select “Control”
2			Select “Error”
3			If OFF is displayed (at right) then there are no errors. Revert to Error/Alarm screen.
4			Select “Alarm”
5			If OFF is displayed (at right) then there are no alarms. In the display at left, an Ave-a Oxygen Concentration Alarm has occurred.

F030601.EPS

3.6.2 Channel Card Self-Diagnostics

Call up “Detailed setup” display.

1. Device setup ---> 4. Detailed setup

	Display	Operation	
1	<pre> AV550G: Detailed setup ← 1 Control 2→Channels 3 Channel status 4 Output condition 5 Device information SEND HOME </pre>		Select “Channels”
2	<pre> AV550G: Channels ← 1→Ch1 detailed setup 2 Ch2 detailed setup 3 Ch3 detailed setup 4 Ch4 detailed setup ↓5 Ch5 detailed setup SAVE HOME </pre>		Select “Ch1 detailed setup” (this example shows how to display Self-Diagnostics for Channel 1).
3	<pre> AV550G: Channels ← 1→Ch1 detailed setup 2 Ch2 detailed setup 3 Ch3 detailed setup 4 Ch4 detailed setup ↓5 Ch5 detailed setup SAVE HOME </pre>		Select “Error”
4	<pre> AV550G: Error Cell voltage OFF Heater temp ON Ch card OFF Card comm OFF EXIT </pre>		<p>If OFF is displayed (at right) then there are no errors. In this example, a “Heater temp” alarm has occurred.</p> <p>Revert to Error/Alarm screen.</p>
5	<pre> AV550G: Ch1 detailed setup ← 1 Ch1 status 2 Sensors 3 Error 4→Alarm SEND HOME </pre>		Select “Alarm”
6	<pre> AV550G: Alarm Oxygen ON Zero conc ratio OFF Span conc ratio OFF Cal time over OFF ↓CJ temp OFF HELP EXIT </pre>		<p>If OFF is displayed (at right) then there are no alarms. In the display at left, an Oxygen concentration alarm has occurred.</p>

F030701.EPS

Table3.1 AV550G Alarms and Errors displayed on HART Communicator

	HART Communicator Display	Explanation	AV550G display
Control card	Ctrl card	Control card abnormality	Error 4
	Ave-a oxygen	Ave-a oxygen concentration outside alarm limits	Alarm 1
	Ave-b oxygen	Ave-b oxygen concentration outside alarm limits	
	Ave-c oxygen	Ave-c oxygen concentration outside alarm limits	
	Process gas	Process gas alarm contact signal received by AV550G	Alarm 6
	Cal gas press lo	Cal gas press lo alarm contact signal received by AV550G	Alarm 7
	Inside temp	AV550G case internal temperature over alarm limit	Alarm 9
Channel card	Cell voltage	Cell emf abnormal	Error 1
	Heater temp	Heater temperature abnormal	Error 2
	Ch card	Channel card abnormality detected	Error 3
	Card comm.	Communications between control card and channel card abnormal	Error 5
	Oxygen	Channel oxygen concentration outside alarm limits	Alarm 1
	Zero conc. ratio	Zero correction factor outside normal range	Alarm 2
	Span conc. ratio	Span correction factor outside normal range	Alarm 3
	Cal time over	Cell emf didn't stabilize during calibration interval	Alarm 4
	CJ temp	Cold (reference) junction temp. outside normal range	Alarm 5
	Asymmetry alarm	Abnormal change in asymmetry correction factor	Alarm 8

3.7 Status Check

You can check Channel Card Status using the HART Communicator. The meanings of these status indications are displayed in the table below.

Call up “Detailed setup” display.

1. Device setup ---> 4. Detailed setup

1

```

Display
AV550G:
Detailed setup  ←
1 Control
2 Channels
3→Channel status
4 Output condition
5 Device information
SAVE HOME
    
```

Operation

```

YZ/
3
    
```

Select “Channel status”

2

```

AV550G:
Channel Status  ←
1 Ch1 sts Measuring
2→Ch2 sts Disable
3 Ch3 sts Measuring
4 Ch4 sts Error
5 Ch5 sts None
SAVE HOME
    
```

In the display example at left, Channel 2 is Disabled, Channel 4 is in Error status, and Channel 5 is Not Installed.

You can scroll the screen to display status of channels 6 and later.

F030801.EPS

Table 3.2 HART Communicator Display and Channel Card Status

HART Communicator status display	Channel card status
None	Card is Not Installed
Disable	Channel is disabled
Warm up	Channel is in Warm Up status
Measuring	Channel is in Measurement status
Blow back	Channel is in Blow Back status
Cal	Channel is in Calibration status
Ind. check	Channel is in Indication Check status
Error	Channel is in Error status
Proc gas	Process Gas alarm has occurred.

4. Maintenance

Various sensor data can be viewed on the HART Communicator.

For more details, refer to “Section 10.1 Display” in the AV550G Instruction Manual.

Call up “Channels” display.

1. Device setup ---> 4. Detailed setup ---> 2. Channels

Display	Operation
<p>1</p> <pre> AV550G: Channels 1→Ch1 detailed setup 2 Ch2 detailed setup 3 Ch3 detailed setup 4 Ch4 detailed setup ↓5 Ch5 detailed setup SAVE HOME </pre>	<div style="border: 1px solid black; padding: 2px; display: inline-block; margin-right: 10px;">STU 1</div> <p>Select “Ch1 detailed setup” (this example shows how to display various data from Channel1).</p>
<p>2</p> <pre> AV550G: Ch1 detailed setup 1 Ch1 status 2→Sensors 3 Error 4 Alarm SAVE HOME </pre>	<div style="border: 1px solid black; padding: 2px; display: inline-block; margin-right: 10px;">VWX 2</div> <p>Select “Sensors”</p>
<p>3</p> <pre> AV550G: Sensors 1→Cell mV -0.02 mV 2 Cell temp 748 degC 3 CJ temp 0 degC 4 TC volt 31.17 mV 5 CJ val 996.6 ohm HELP SAVE HOME </pre>	<p>Various data from Channel 1 is displayed. Meanings of data labels in “Sensors” displayed on the HART communicator are shown in the table below.</p>

F030801.EPS

Table 4.1 Meaning of Data Labels in “Sensors”

HART Communicator display	Meaning of data
Cell mV	Cell emf displayed
Cell temp	Cell temperature is displayed
CJ temp	Cold junction (reference junction) temperature is displayed
TC volt	Thermocouple emf is displayed
CJ val	Cold junction (reference junction) resistance is displayed
Heater duty	Heater duty cycle ON time is displayed

Revision Record

Manual Title : Model EXAx t AV550G HART Protocol

Manual Number : IM 11M12D01-51E

Edition	Date	Remark (s)
1st	Feb. 2005	Newly published
