**User's
Manual**

EXA OR

**Model OR100
Panel Mount ORP Converter**

IM 12C11A01-01E

vigilantplant®

◆ Introduction

This manual covers the specifications, installation, operation and maintenance of the panel-mount version of the OR100 ORP converter. Please read this before using the OR100.

There are manuals for the related EXA100 series as follows:

Refer to them as required.

Model code	Manual Name	IM No.
PH100	Panel Mount pH Converter	IM 12B11A01-01E
OR100	Panel Mount ORP Converter	IM 12C11A01-01E
SC100	Panel Mount Conductivity Converter	IM 12D11A01-01E
PH10FP	KCl Refillable pH Sensor	IM 12B11C01-01E
PH10RP	KCl Replenish-free pH Sensor	IM 12B11C02-01E
OR10FP	KCl Refillable ORP Sensor	IM 12C11C01-01E
OR10RP	KCl Replenish-free ORP Sensor	IM 12C11C02-01E
SC10XB	Conductivity Sensor for SC100	IM 12D11C01-01E
WTB100	Terminal Box for EXA100 series	IM 12B11E01-01E
WF100	Extension Cable for EXA100 series	IM 12B11F01-01E
PH10HLD	Immersion Holder for EXA100 series	IM 12B11D01-01E
PH10HG	Guide-pipe Holder for EXA100 series	IM 12B11D02-01E

Not available in US

T000.eps

These products are used in Japan typically.

◆ For the safe use of this equipment

(1) About This Manual

- This manual should be passed on to the end user.
- The contents of this manual are subject to change without prior notice.
- The contents of this manual shall not be reproduced or copied, in part or in whole, without permission.
- This manual explains the functions contained in this product, but does not warrant that they will suitably the particular purpose of the user.
- Every effort has been made to ensure accuracy in the preparation of this manual. However, when you realize mistaken expressions or omissions, please contact the nearest Yokogawa Electric representative or sales office.
- This manual does not cover the special specifications. This manual may not be revised when changes in the hardware or software of the product does not affect the functions or performance of the product.
- If the product is not used in a manner specified in this manual, the safety of this product may be impaired and the warranty voided.

(2) Safety and Modification Precautions

- Follow the safety precautions in this manual when using the product to ensure protection and safety of the human body, the product and the system containing the product.

(3) The following safety symbols are used on the product as well as in this manual.

WARNING

A WARNING sign denotes a hazard. It calls attention to procedure, practice, condition or the like, which, if not correctly performed or adhered to, could result in injury or death of personnel.

CAUTION

A CAUTION sign denotes a hazard. It calls attention to procedure, practice, condition or the like, which, if not correctly performed or adhered to, could result in damage to or destruction of part or all of the product.

IMPORTANT

An IMPORTANT sign denotes that attention is required to avoid damage to the instrument or system failure.

NOTE

A NOTE sign denotes information necessary for essential understanding of operation and features.

Tip

This symbol gives information that complements the current topic.

SEE ALSO

This symbol identifies a source to which to refer.

 Protective Ground Terminal

 Function Ground Terminal (Do not use this terminal as the protective ground terminal.)

 Alternating current

 Power switch ON status

 Power switch OFF status

◆ NOTICE and Cautions

• Check specifications

When the instrument arrives, unpack the package with care and check that the instrument has not been damaged during transportation. In addition, please check that the specification matches the order, and that required accessories are not missing. Specifications can be checked by the model codes on the nameplate. Refer to Chapter 1.2 Specifications for the list of model codes.

• Details on operation parameters

When the OR100 panel mount ORP Converter at the user site, it will operate based on the operation parameters (initial data Table 5.1 to 5.3) set before shipping from the factory.

Ensure that the initial data is suitable for the operating conditions before starting operation. Where necessary, set the instrument parameters for appropriate operation. For details of setting data, refer to chapters 4 to 5.

When user changes the operation parameters, it is recommended to note down the changed setting data.

Front Panel of OR100



LED Display Symbols

- Alphanumerics are represented as follows on the LED display

Alphanumerics	LED Display	Alphanumerics	LED Display	Alphanumerics	LED Display
A	<i>A</i>	N	<i>n</i>	0	<i>0</i>
B	<i>b</i>	O	<i>o</i>	1	<i>1</i>
C	<i>C</i>	P	<i>P</i>	2	<i>2</i>
D	<i>d</i>	Q	<i>q</i>	3	<i>3</i>
E	<i>E</i>	R	<i>r</i>	4	<i>4</i>
F	<i>F</i>	S	<i>S</i>	5	<i>5</i>
G	<i>G</i>	T	<i>t</i>	6	<i>6</i>
H	<i>H</i>	U	<i>U</i>	7	<i>7</i>
I	<i>I</i>	V	<i>V</i>	8	<i>8</i>
J	<i>J</i>	W	<i>W</i>	9	<i>9</i>
K	<i>K</i>	X			
L	<i>L</i>	Y	<i>Y</i>		
M	<i>M</i>	Z	<i>Z</i>		

◆ After-sales Warranty

Warranty and Service

Yokogawa products and parts are guaranteed free from defects in workmanship and material under normal use and service for a period of (typically) 12 months from the date of shipment from the manufacturer. Individual sales organisations can deviate from the typical warranty period, and the conditions of sale relating to the original purchase order should be consulted. Damaged caused by wear and tear, inadequate maintenance, corrosion, or by the effects of chemical processed are excluded from this warranty coverage.

In the event of a warranty claim, the defective goods should be sent (freight paid) to the service department of the relevant sales organisation for repair or replacement (at Yokogawa discretion.) The following information must be included in the letter accompanying the returned goods:

- Part number, model code and serial number
- Original purchase order and date
- Length of time in service and a description of the process
- Description of the fault, and the circumstances of failure
- Process/environmental conditions that may be related to the installation failure of the device
- A statement whether warranty or non-warranty service is requested
- Complete shipping and billing instructions for return of goods, plus the name and phone number of a contact person who can be reached for further information.

Returned goods that have been in contact with process fluids must be decontaminated/disinfected before shipment. Goods should carry a certificate to this effect, for the health and safety of our employees. Material safety data sheets should also be included for all components of the processes to which the equipment has been exposed.

Contents

◆ Introduction	i
◆ For the safe use of this equipment	ii
◆ NOTICE and Cautions	iii
◆ After-sales Warranty	iv
1. Overview	1-1
1.1 EXA OR100 ORP converter	1-1
1.2 Check the specifications	1-1
1.3 Features of the EXA OR100 ORP converter	1-1
1.4 Standard Specifications	1-2
2. Preparation for Operation	2-1
2.1 Unpacking	2-1
2.2 Choosing an Installation Location	2-1
2.3 External Dimensions	2-2
2.4 Panel Cutout Dimensions	2-3
2.5 Mounting	2-3
3. Wiring.....	3-1
3.1 Pulling in Wiring	3-2
3.2 Noise prevention	3-2
3.3 Wiring Terminal Diagram	3-3
3.4 ORP sensor wiring	3-5
3.5 Wiring cable to intermediate terminal box	3-6
3.6 Output Signal Cable Wiring	3-7
3.7 Contact output wiring.	3-7
3.7.1 Wiring when S1 is used	3-7
3.7.2 Wiring for S2 (for two-contact-output case) or S2, S3 and S4 (four-contact output case)	3-9
3.8 Power and Ground Wiring	3-9
4. Overview of Operation Panel	4-1
4.1 Names and functions of operation panel keys	4-1
4.2 Key Operation	4-1
4.3 Switching Display Screens	4-2
4.4 Display Screen Examples	4-3
4.4.1 Initial display	4-3
4.4.2 Measurement screen	4-3
4.4.3 Calibration screen	4-4
4.4.4 Setting screen	4-4

5. Operation	5-1
5.1 Start up	5-1
5.1.1 Checking wiring	5-1
5.1.2 Start up ORP converter	5-1
5.1.3 Data setting	5-1
6. Sensor Check and Calibration Procedures	6-1
6.1 Overview of Sensor Checks and Calibration	6-1
6.1.1 Sensor checks	6-1
6.1.2 Calibration (manual calibration)	6-1
6.1.3 Sensor check solution	6-1
6.2 Checking Sensors	6-1
6.2.1 Preliminary	6-1
6.2.2 Checking sensors	6-2
6.3 Manual Calibration	6-2
6.3.1 Preliminary	6-2
6.3.2 Manual calibration procedures	6-3
6.4 Canceling Calibration	6-4
6.5 If an Error Occurs during Calibration	6-4
6.5.1 Recovering from an Error	6-4
6.5.2 Quitting calibration screen	6-4
7. Maintenance and Cleaning	7-1
7.1 Periodic Maintenance	7-1
7.1.1 Sensor cleaning	7-1
7.1.2 Checking the KCl solution for ORP sensor	7-1
7.2 Preventive Maintenance	7-1
7.2.1 ORP converter terminal isolation	7-1
7.2.2 Checking ORP sensor displays	7-1
8. Troubleshooting.....	8-1
8.1 Unexpected Value Displayed (Pinpointing the Causes of Problems with Converter or Sensor)	8-1
8.2 Displaying Errors	8-3
8.3 Checks and Corrective Action	8-3
8.3.1 ORP measurement out of range	8-3
8.3.2 Converter defective	8-3
8.3.3 Calibration asymmetry potential error	8-3
Customer Maintenance Parts List	i
Revision Record	i

1. Overview

1.1 EXA OR100 ORP converter

The EXA OR100 ORP converter is a panel-mount unit with built-in general-purpose preamp, large 4-digit LED display for measured value and 4-digit LED display for settings.

1.2 Check the specifications

The model number and suffix codes are shown below. Check that what you were supplied is the same as what you ordered.

Model	Suffix code	Option code	Description
OR100			Panel mounted ORP converter
_____	-A		Always -A
Label language	-E		English
	-J		Japanese
Contact output	-21		2 contact outputs
	-41		4 contact outputs
_____	-NN		Always -NN
Option	Construction	/65	with sealing for IP65 (front only)

T1.0E.EPS

1.3 Features of the EXA OR100 ORP converter

- (1) Large 4-digit display.
- (2) You can easily calibrate the unit with standard solution.
- (3) You can select either two output contacts or four ; and you can select each contact output type from : high, low, high high, low low, and high high / low low.
- (4) Isolated 4 to 20 mA analog output of measured value.
- (5) Calibration values and measured values can be read to 1 mV, making high accuracy measurement and calibration possible.
- (6) The operation panel is rated for operation in an IP55. IP65 for front panel is optional.
- (7) 96 mm x 96 mm DIN size panel mount instrument. Depth is 120 mm and weight is 600 g.
- (8) Full set of self-diagnostic functions with indication of errors such as measurement out of range, converter abnormal, calibration-time error.

1.4 Standard Specifications

Measurement: Oxidation-reduction potential (ORP) of a solution
 Measuring range: -1500 to 1500 mV
 Indication
 Display: Digital (LED)
 Range: -1500 to 1500 mV
 Resolution: 1 mV
 Indication items: ORP reading, setting, status
 Input signal
 ORP input range: -1500 to 1500 mV
 Transmission signal output
 Number of output points: 1 output, ORP reading only
 Output signal: 4 to 20 mA DC, isolated
 Load resistance: 600Ω or less
 Transmission signal range: Configurable within measuring range (by 100 mV unit),
 factory setting: -1500 to 1500 mV, minimum span: 100 mV
 Maintenance output signal: Output hold “enabled/disabled” selectable
 Hold output value: Last measured value/preset value (2.0 to 20.8 mA) selectable
 Fail output signal: Downscale burnout (2 mA) “enabled/disabled” selectable

Contact output

Contact type : Relay contact output
 Number of contacts : 2 or 4 outputs (must be specified when ordering)
 Contact action : On/Off action
 Contact functions : Selectable: High, low, high-high, low-low, high-high/low-low limit alarms, FAIL
 Contact output hysteresis : 0 to 1000 mV (configurable)
 Contact output delay time : 0 to 200 seconds (configurable)

Contact rating : When 2 contact outputs specified

S1 : 240 VAC 3A or 30 V DC 3A (resistance load), (NC/NO/COM, 3 terminals)
 S2 : 240 VAC 3A or 30 V DC 3A (resistance load), (NO)

When 4 contact outputs specified

S1 : 240 VAC 3A or 30 V DC 3A (resistance load), (NC/NO/COM, 3 terminals)
 S2, S3, S4 : 240 V AC 3A or 30 V DC 3A (resistance load), (NO), shared common
 Maximum load current on common is 3A.

Contact status:

Table 1.1

Contact	Function selected						
	H, L, HH, LL, HH/LL limit alarms				FAIL		
	Power off	Power on		Power off	Power on		
No alarm		Alarm	No alarm		Alarm		
S1	NO-COM	Open	Open	Closed	Open	Closed	Open
	NC-COM	Closed	Closed	Open	Closed	Open	Closed
S2		Open	Open	Closed	Open	Closed	Open
S3 when specified		Open	Open	Closed	Open	Closed	Open
S4 when specified		Open	Open	Closed	Open	Closed	Open

Note: When a contact is activated, the LED on display panel turns on.

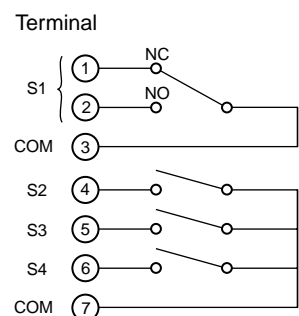

Ambient temperature : -5 to 45 °C
 Storage temperature : -25 to 70 °C
 Ambient humidity : 10 to 90% RH, non-condensing
 Construction : Front panel : Dust-proof and drip-proof construction IP55, IP65 (when “/65” option specified)
 Materials : ABS resin and polycarbonate

Power supply : Rated voltage 100 to 240 V AC ($\pm 10\%$), 50/60 Hz
Power consumption : Max. 9 VA
Weight : Approx. 600g
Dimensions : 96 (W) x 96 (H) x 122 (D) mm
Mounting : Panel mount
Panel cutout dimensions : 92 (W) x 92 (H) mm
Wiring : M4 screw terminal (protective grounding terminal),
M3.5 screw terminal (other terminals)
Grounding : grounding resistance 100 Ω or less

Functional specifications

Calibration function : Manual shift calibration (one point calibration at specified setpoint)
Zero shift range: -500 to 500 mV
Self-diagnostics function:
FAIL output : ORP measuring range failure and converter failure
Error indication: Zero shift failure, standard solution measuring range failure

Calibration function

Converter performance: under normal operating conditions
Linearity: ± 3 mV
Repeatability: ± 2 mV

Sensors can be connected with OR100:

OR10FP KCl Refillable ORP Sensor for OR100*, OR10RP Replenish-free ORP Sensor for OR100*,
FU20 (no simultaneous pH measurement available), OR8ERG*, OR8EFG*
Maximum total connection cable length: 50 m (sensor cable length included)

* Not available in US. These sensors are used in Japan typically.

2. Preparation for Operation

2.1 Unpacking

When the instrument arrives, unpack the package with care and check that the instrument has not been damaged during transportation. In addition, please check that the specification matches the order, and required accessories are not missing. If damage is found retain the original packing materials (including the outer box) and immediately notify the carrier and the relevant Yokogawa sales office.

2.2 Choosing an Installation Location

The OR100 converter should be installed as close as possible to the sensor to avoid long cable runs between sensor and converter, the cable length should not exceed 50 meters (150 feet.) Select an installation site where:



CAUTION

To minimize the risk of electric shock, the converter should be mounted on the converter panel before power is applied.

- Mechanical vibrations and shocks are negligible
- No relay/power switches are in the direct environment
- Access is possible rear of the unit for wiring
- The transmitter is not mounted in direct sunlight or severe weather conditions
- Maintenance procedures are possible (avoiding corrosive environments)

The ambient temperature and humidity of the installation environment must be within the limits of the instrument specifications.

2.3 External Dimensions

• ORP Converter

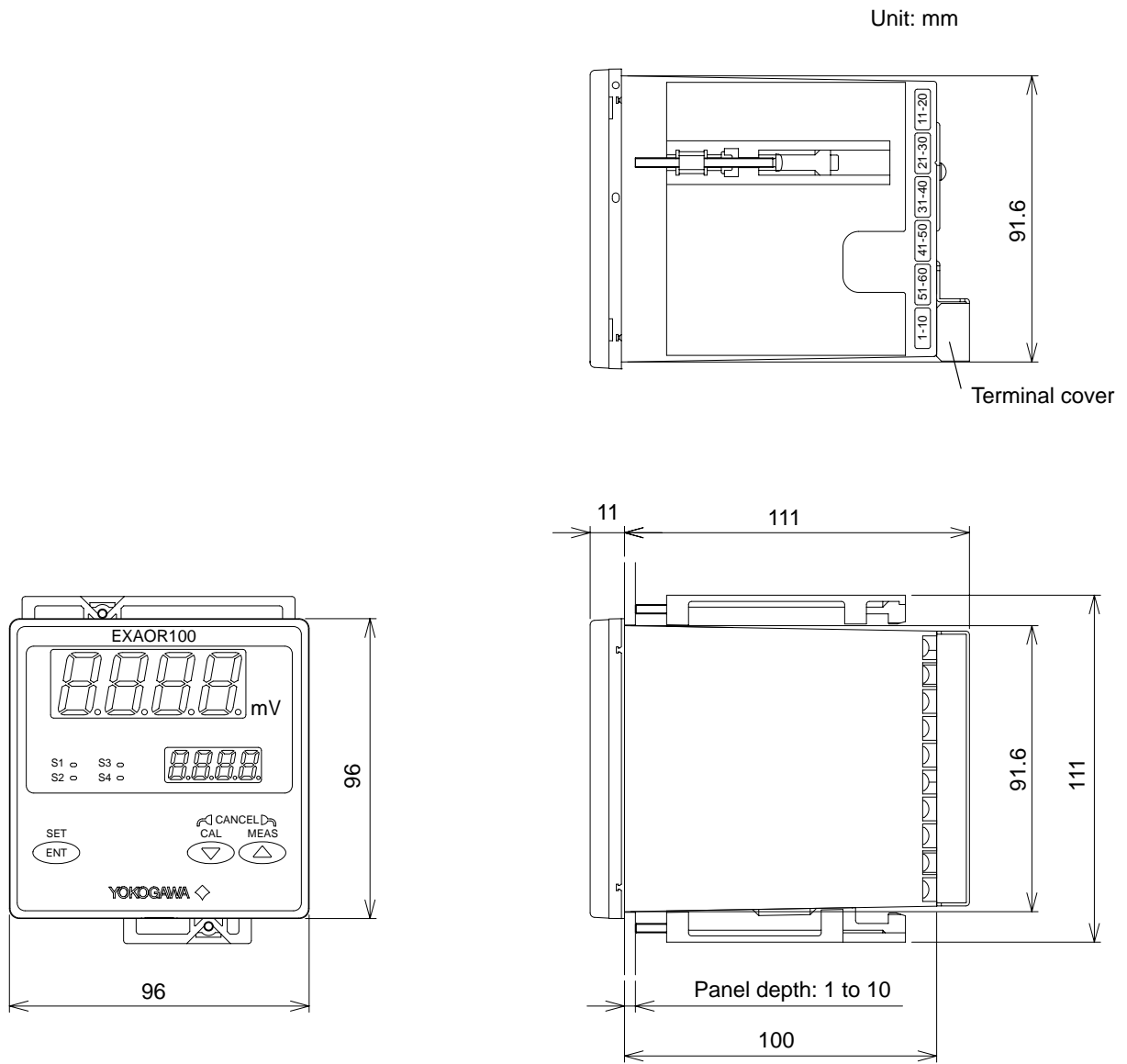

Fig. 2.1

2.4 Panel Cutout Dimensions

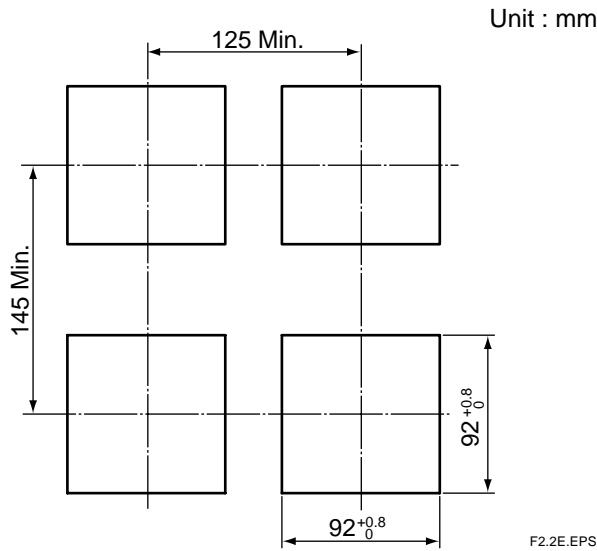

Fig. 2.2

2.5 Mounting

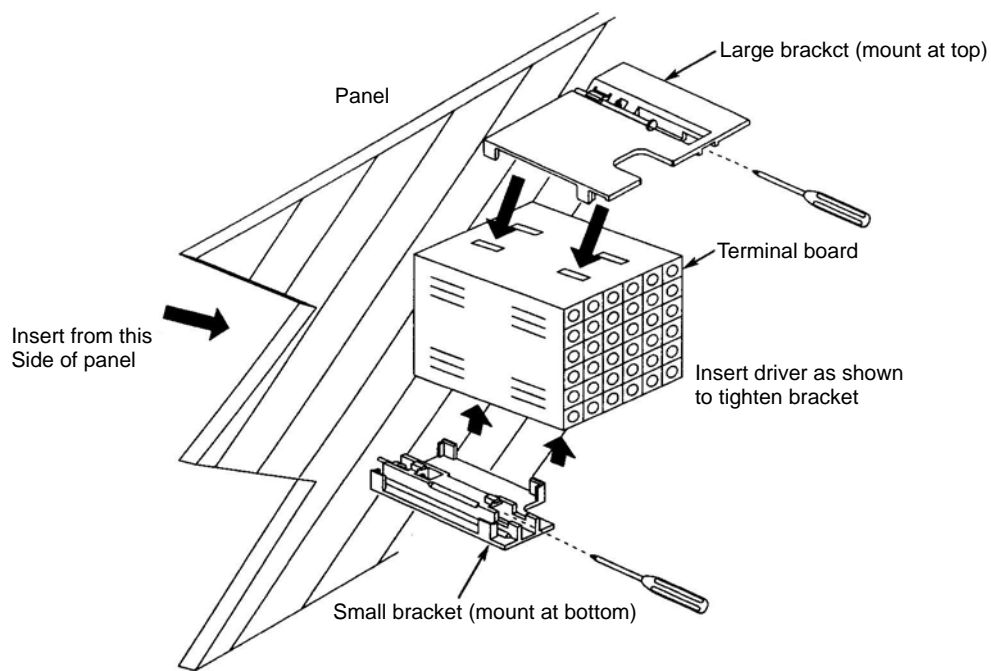

Fig. 2.3

Procedure 1

Prepare panel cut out according to dimensions shown on previous page.

Procedure 2

Insert instrument from the front of the panel.

Procedure 3

Mount top and bottom brackets (see figure) to fix instrument to panel.

 **IMPORTANT**

If instrument is a tight fit in cutout, do not force it as case or mounting brackets may be damaged.

 **IMPORTANT**

The instrument may be installed with the rear inclined at an angle up to 30° below front.
Do not incline with below rear.

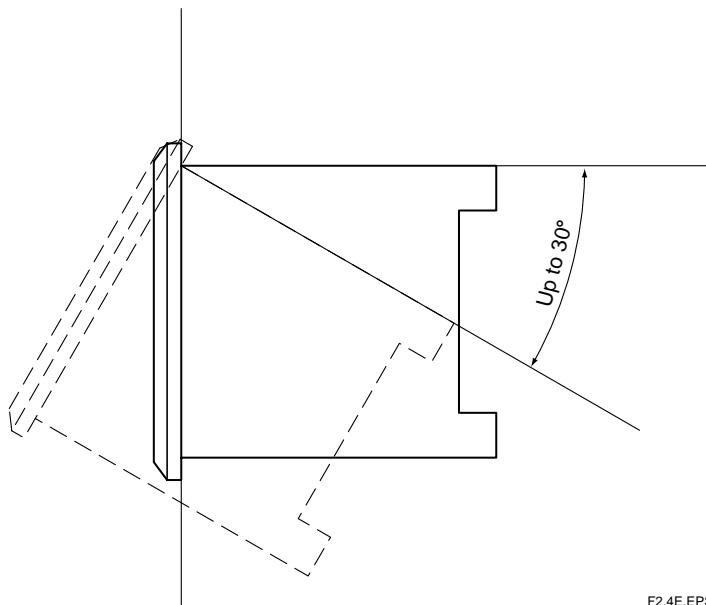

Fig. 2.4

F2.4E.EPS

3. Wiring

This section explains wiring of the EXA OR100 ORP converter.

WARNING

Be sure to turn off power supply, and check with a tester or the like that connected cables do not have dangerous voltages applied. Do not touch terminals if power may be applied.

The recommended specifications for wiring terminals are shown below.

(1) Protective grounding terminal

Use crimp-on terminals, designed to fit an ISO M4 screw, with an insulating sleeve.

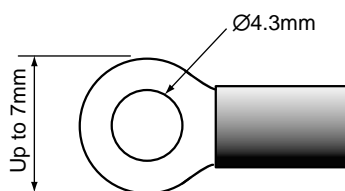

F3.1E.EPS

Fig. 3.1

■ Recommended terminals

Table 3.1

Maker	model	For wire size:	Tightening torque
JST Co., Ltd	V2-M4	2mm ²	1.2N · m { 12 kgf · cm } Up to or less

T3.1E.EPS

(2) Other terminals

Use crimp-on terminals, designed to fit an ISO M3.5 screw, with an insulating sleeve.

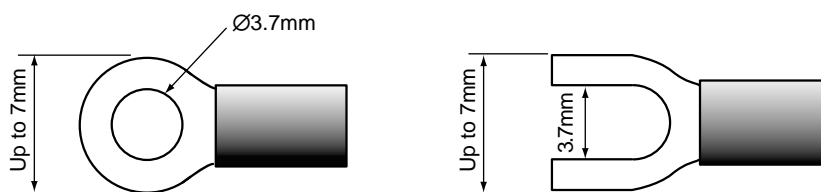

F3.2E.EPS

Fig. 3.2

■ Recommended terminals

Table 3.2

Maker	model	For wire size:	Tightening torque
Japan AMP Co., Ltd	1.25-YS3A	0.3~1.65mm ²	0.8N · m { 8 kgf · cm } Up to or less
JST Co., Ltd	YD1.25-3.5		

T3.2E.EPS

3.1 Pulling in Wiring

When wiring cables to terminals on the rear of the instrument, pull the cables into the instrument in the direction shown in Fig. 3.3.



There's a terminal wiring diagram on the instrument nameplate on the side of the converter.

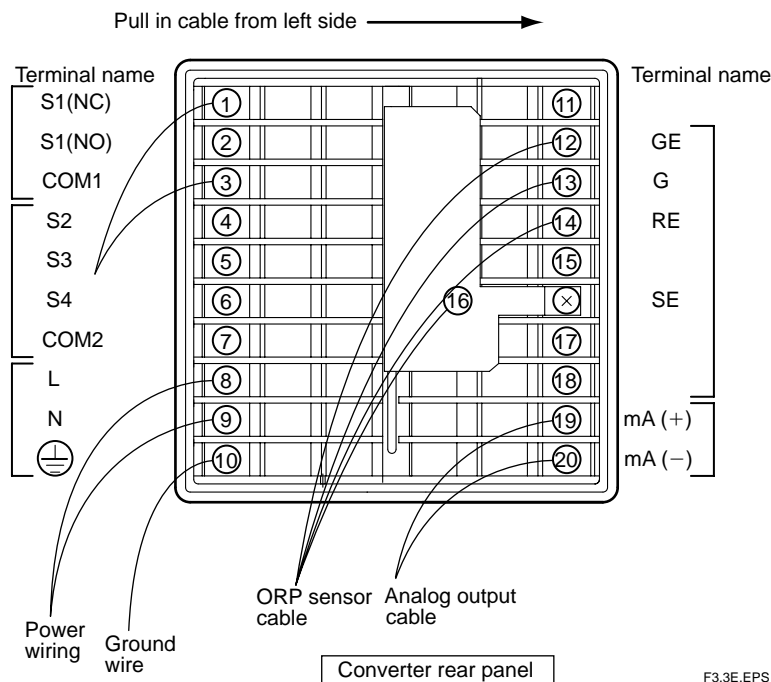

Fig. 3.3 Direction to pull in wiring

F3.3E.EPS

3.2 Noise prevention

When wiring, take the following precautions to minimize the effects of noise:

- * Keep input circuit wiring as far as possible from power or ground wiring.
- * Shielded wires, with single-point grounding, are effective for minimizing pickup of static electric fields.
- * Twisted pair wire is effective in minimizing inductive noise pickup.

3.3 Wiring Terminal Diagram

There are wiring terminals on the rear of the OR100 converter. Wire to terminals 1 to 10 and terminals 11 to 20 as shown in Fig. 3.4. The terminal block cannot be removed.

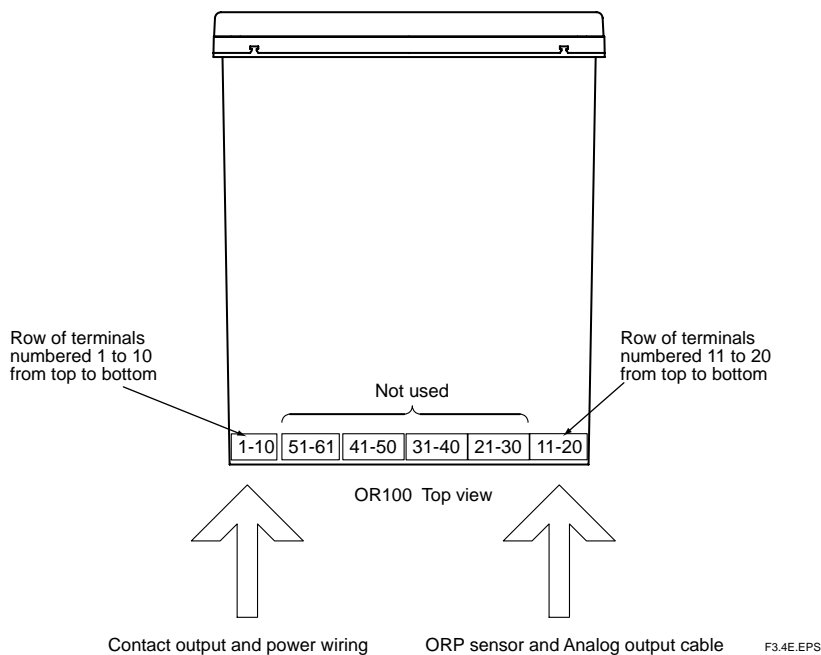

Fig. 3.4 Cable wiring position

(1) When intermediate terminal box is used *



NOTE

Terminal size of protective ground is ISO M4, other terminal size is ISO M3.5. There's a terminal wiring diagram on the instrument nameplate on the side of the converter.

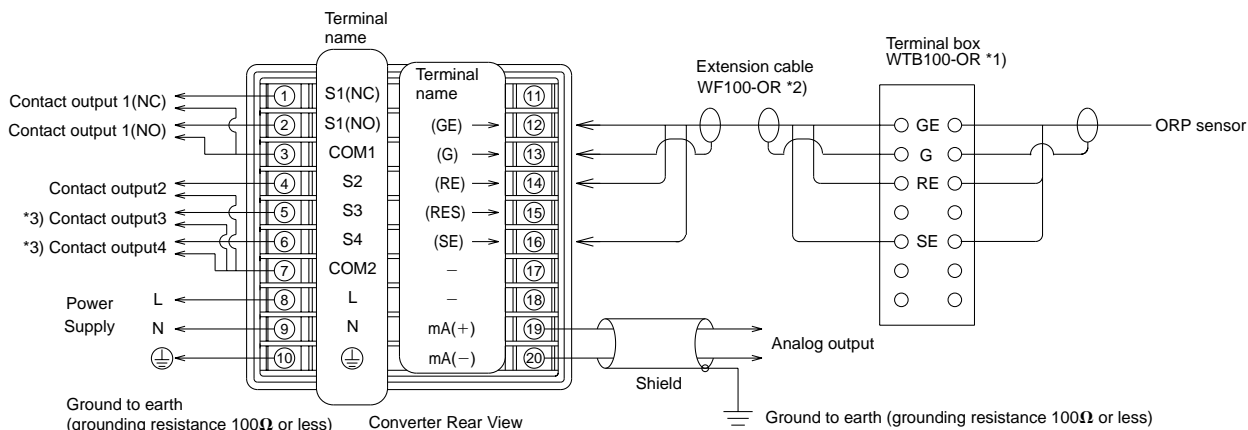

Note: Terminals are M3.5 screws. Terminal diagram is shown on the name plate on the side of the converter.

Fig. 3.5 Wiring diagram when intermediate terminal box is used

* This combination is used in Japan typically.

(2) When intermediate terminal box is not used.

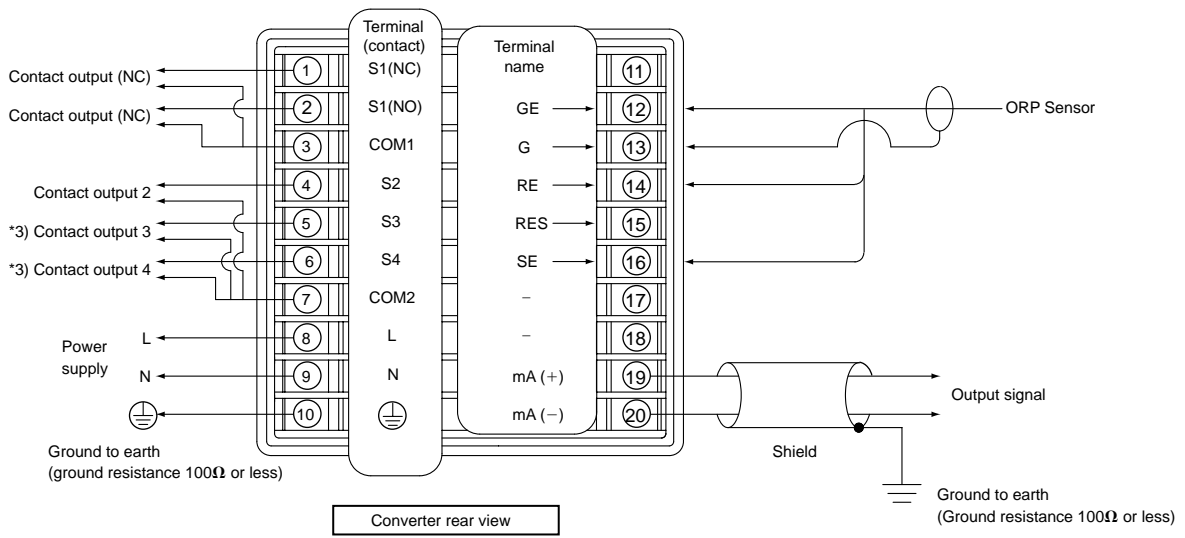

Fig. 3.6 Wiring diagram when intermediate terminal box is not used

When only two contact outputs are used, contact outputs 3 and 4 (S3 and S4) are not used. When four contact outputs are used, S3 and S4 share the same common lead (COM2).

Table 3.1 Terminal wiring example

Terminal no.	Signal name	Signal description
1	S1(NC)	Contact output 1 (relay contact) NC
2	S1(NO)	Contact output 1 (relay contact) NO
3	COM1	Contact output 1 (common)
4	S2	Contact output 2 (relay contact)NO
5	S3	Contact output 3 (relay contact) NO
6	S4	Contact output 4 (relay contact) NO
7	COM2	Contact output 2 (common) (shared by S2,S3 & S4)
8	L	Power line L
9	N	Power line N
10	⊕	Protective grounding terminal
11	-	Reserved
12	GE	Measure electrode input terminal
13	G	Measure electrode shield terminal
14	RE	Reference electrode input terminal
15	-	Reserved
16	SE	Ground electrode (cable shield) terminal
17	-	Reserved
18	-	Reserved
19	mA(+)	Analog output terminal (+)
20	mA(-)	Analog output terminal (-)

T3.3E.EPS

NOTE

Figures 3.5 and 3.6 seem to indicate that cable can be pulled in from right hand side, but in fact cable can only be pulled in from left hand side as described in Sec. 3.1.

3.4 ORP sensor wiring

This section describes connection of the Model OR10FP KCl Refillable ORP sensor or the Model OR10RP KCl Replenish-free ORP sensor to the OR100 ORP converter.

 **NOTE**

For a description of how to connect these sensors via extension cable and intermediate terminal box, refer to IM 12B11E01-01E for the WTB100 intermediate terminal box, and refer to IM 12B11F01-01E for the WF100 extension cable.

The procedure for connecting a sensor to the OR100 ORP converter is as follows:

- (1) Connect the ORP sensor (detector) by cable to the terminals. The color coding of the wires in the cable and the corresponding terminals that they are connected to are listed below:

① ORP converter terminal no.

- 11
- 12
- 13
- 14
- 15
- 16
- 17
- 18

Cable core color code for OR10FP and OR10RP ORP sensors

- Do not use
- Red (GE)
- Green (G)
- Brown (RE)
- Do not use
- Black (SE)
- Do not use
- Do not use

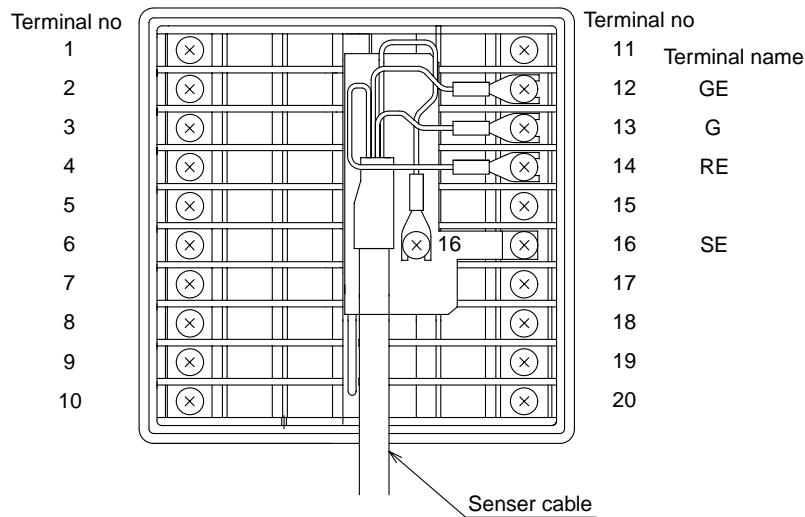

Converter rear panel diagram

F3.4.1E.EPS

(Reference) A tag which indicates the colors, markings, and numbers corresponding to terminals, is attached the sensor cable.

② ORP converter terminal no.

11
12
13
14
15
16
17
18

Cable core color code for
OR8EFG and OR8ERG ORP detectors

Do not use
Red (GE)
Green (G)
Brown (RE)
Do not use
Black (SE)
Do not use
Do not use

 **NOTE**

When using the OR8EFG or OR8ERG which have pin terminals, be sure to replace the SE pin terminal with a forked terminal, as if you use the pin terminal is prone to pulling out, resulting in unreliable measurements.

③ ORP converter terminal no.

11
12
13
14
15
16
17
18

Cable core code for FU20 ORP detectors

Do not use
14 (GE)
Do not use
13 (RE)
Do not use
Connect to no.12 of ORP converter
Do not use
Do not use

 **IMPORTANT**

FU20 cable core numbers do not agree with converter terminal numbers, so care is required.
You should also tape ends of unused wires, and secure wires so they cannot move around, to help avoid inadvertent short circuits.

3.5 Wiring cable to intermediate terminal box

When the OR100 ORP converter is separated by a distance from the ORP detector, use the WTB100 or BA10 terminal box and WF10 extension cable to connect them.

3.6 Output Signal Cable Wiring

WARNING

To minimize the risk of electric shock, before connecting or disconnecting wires be sure to confirm that the ORP converter power is OFF.

The output signal wiring from the OR100 converter connects to recorders or the like. Use two-core shielded cable for this wiring.

- (1) Connect connecting cable to the terminals. Be sure to use the recommended terminals and be sure that they are the correct size for the cable copper core diameter.
- (2) As shown in Figures 3.4 and 3.5 of Section 3.3, ground to earth and ground connection at one point only.

3.7 Contact output wiring.

3.7.1 Wiring when S1 is used

A terminal cover is fitted to reduce the risk of electric shock when power is applied. When connecting contact output wiring, you need to loosen the two cover screws to remove the cover. After completing the wiring, take care not to forget to replace the cover.

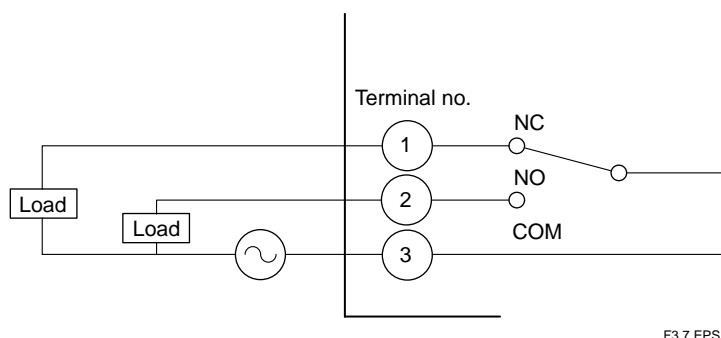

F3.7.EPS

Fig. 3.7 Relay contact output wiring

- * If you want to connect a load which exceeds the contact rating (voltage rating 240 V AC, current rating 3A resistive load, 30 VDC 3A resistive load) then you need to use a slave relay.
- * If you connect an inductive load like a solenoid valve or slave relay then in parallel with the contacts you should connect a CR filter (when switching AC) or a diode (when switching DC), or contact life may be affected.

WARNING

* Be sure to disconnect power before removing the terminal cover. Since there is the risk of electric shock, turn off power and confirm that terminals are not live before wiring.

Under no circumstances should terminals be touched while power is applied.

Recommended CR filters

Table 3.2

Maker	Models
MATSUO Electric co.,Ltd	CR UNIT 953, 955 etc.
SHIZUKI Electric co.,Ltd	SKV, SKVB etc.
RUBYCON Corporation	CR-CFS, CR-U etc.

T3.4E.EPS

• For an DC relay

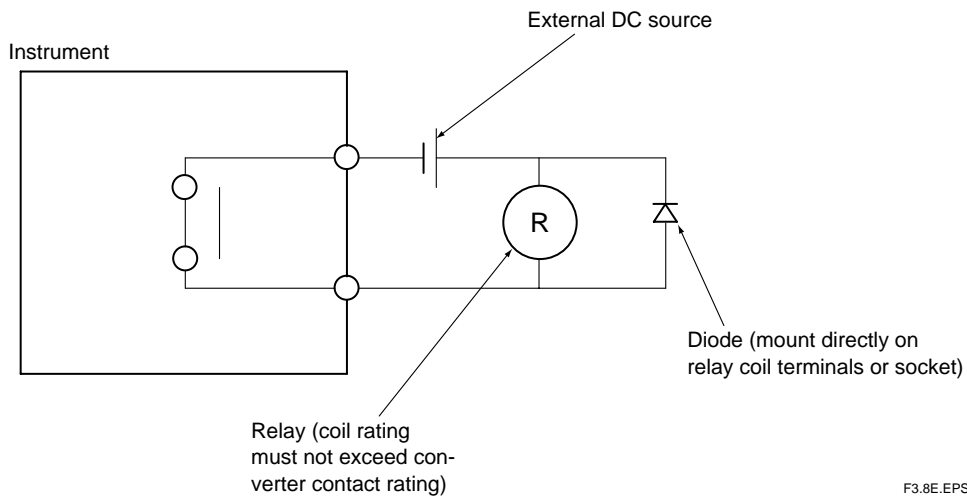

F3.8E.EPS

Fig. 3.8

• For an AC relay

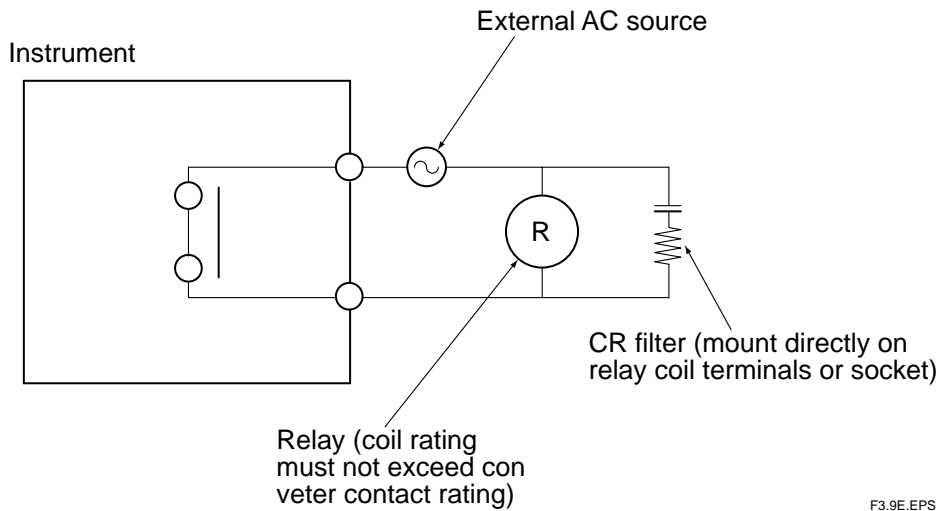

F3.9E.EPS

Fig. 3.9

3.7.2 Wiring for S2 (for two-contact-output case) or S2, S3 and S4 (four-contact output case)

A terminal cover is fitted to reduce the risk of electric shock when power is applied. When connecting contact output wiring, you need to loosen the two cover screws to remove the cover. After completing the wiring, take care not to forget to replace the cover.

- (1) If you want to connect a load which exceeds the contact rating (voltage rating 240 V AC, current rating 3A resistive load) then you need to use a slave relay as shown in Sec. 3.7.1.
- (2) If switching a very small current, then -- if possible -- connecting a bleeder resistor in parallel with the relay (or the like) that is the load, can improve contact reliability.
- (3) If you connect an inductive load like a solenoid valve or slave relay then in parallel with the contacts you should connect a CR filter (when switching AC) or a diode (when switching DC), or contact life may be affected. Contact life is typically at least 10,000 switching operations with a resistive load.
- (4) Use the recommended terminals to terminate connecting cables, and make sure that they are the correct size to match the cable core diameter.

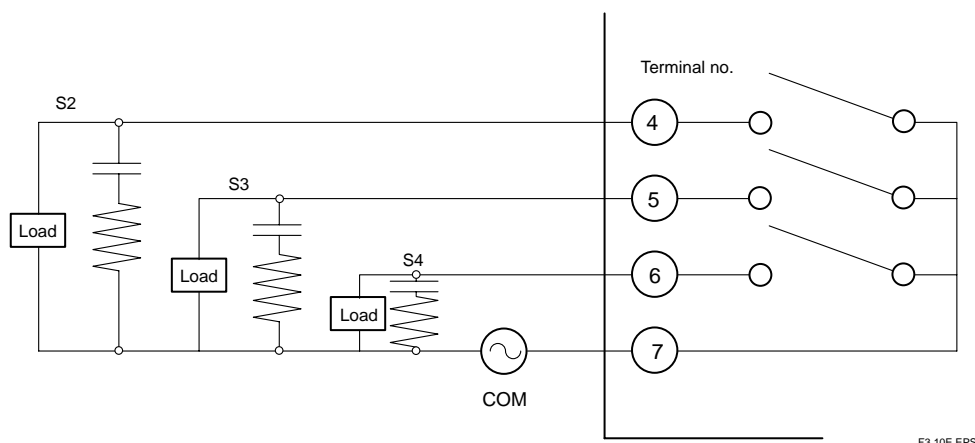

Fig. 3.10

3.8 Power and Ground Wiring

- * Power: This wiring should connect a power source of the correct voltage and frequency to the OR100 ORP Converter. The power wiring should be heavy vinyl sheath cable rated at 600V.
- * Ground: Ground to earth (ground resistance 100 ohms or less).

A terminal cover is fitted to reduce the risk of electric shock when power is applied. When connecting contact output wiring, you need to loosen the two cover screws to remove the cover. After completing the wiring, take care not to forget to replace the cover.

WARNING

- * Be sure to disconnect power before removing the terminal cover. Since there is the risk of electric shock, turn off power and confirm that terminals are not live before wiring

NOTE

The OR100 ORP converter does not have a power switch built in. You should add an on-off switch with two poles to disconnect both sides of the power line near the equipment.

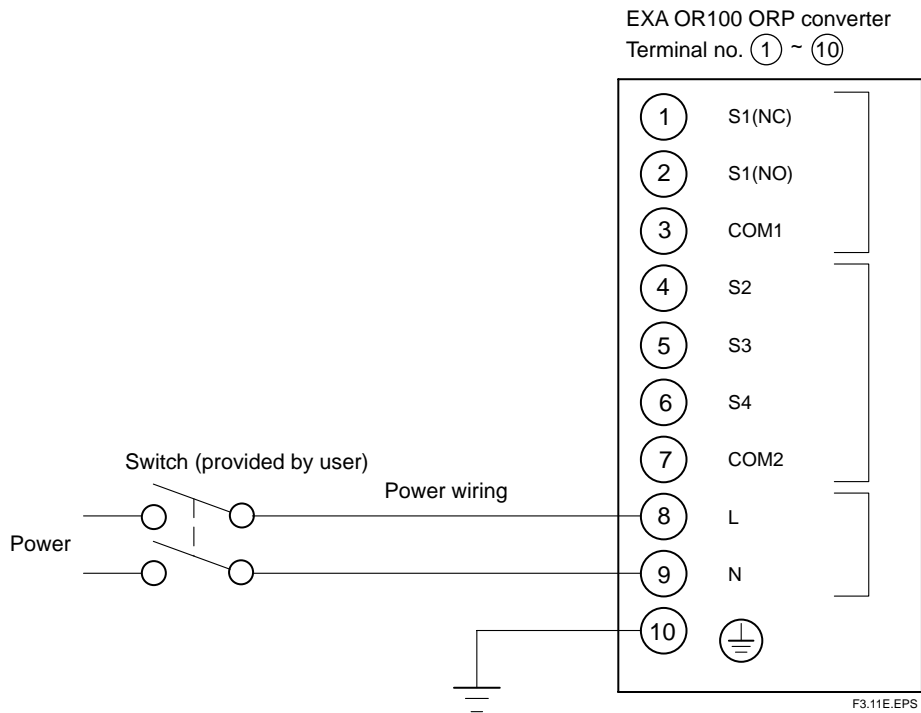

Fig. 3.11

 **NOTE**

Any errors in power and ground wiring may damage the converter. Before applying power to the converter, be sure to check the wiring.

4. Overview of Operation Panel

4.1 Names and functions of operation panel keys

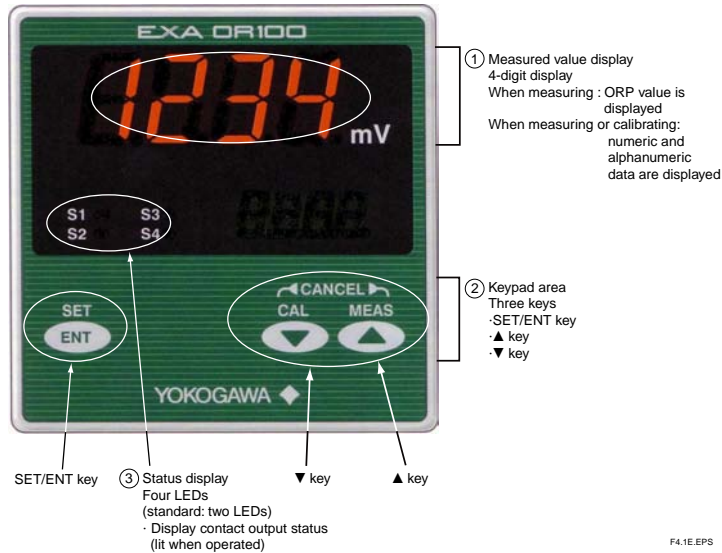

Fig. 4.1

4.2 Key Operation

On the OR100 front panel, there are three keys for screen mode switching and data entry.

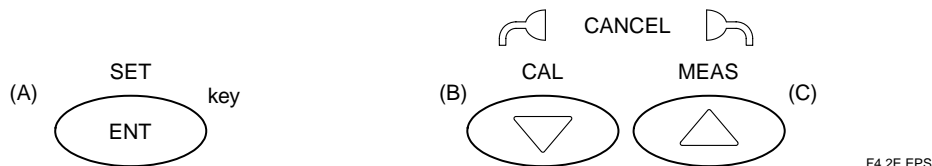

Fig. 4.2 Layout of three keys on front panel

Main uses of these keys are as follows:

(A) SET/ENT key: Used to conform mode changes and data settings.

- From the measurement panel, if you hold down the SET/ENT key for at least three seconds, the data setting screen is then displayed.

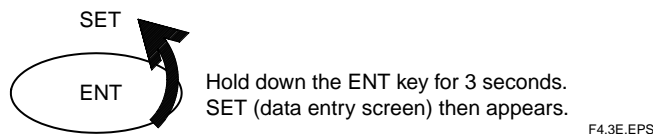

Fig. 4.3

(B) ▼ key: Use to select different menu items or reduce data setting value.

- Holding down this key for at least three seconds switches to the calibration screen.

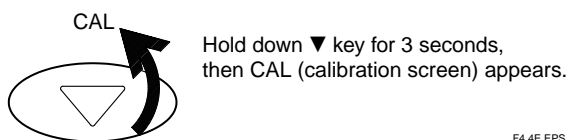

Fig. 4.4

(C) ▲ key: Use to select different menu item or increase data setting value.

- Holding down this key for at least three seconds from calibration or data setting top screen switches to the measurement screen.

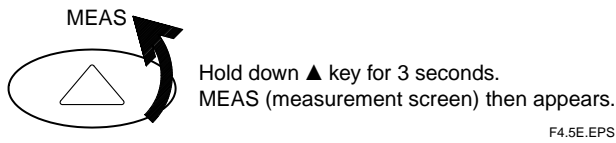

Fig. 4.5

(B) and (C) Pressing ▲ and ▼ keys simultaneously cancel operations.

4.3 Switching Display Screens

The OR100 has three menu screens: measurement, calibration and data setting screens. The screen-switching diagram is shown below.

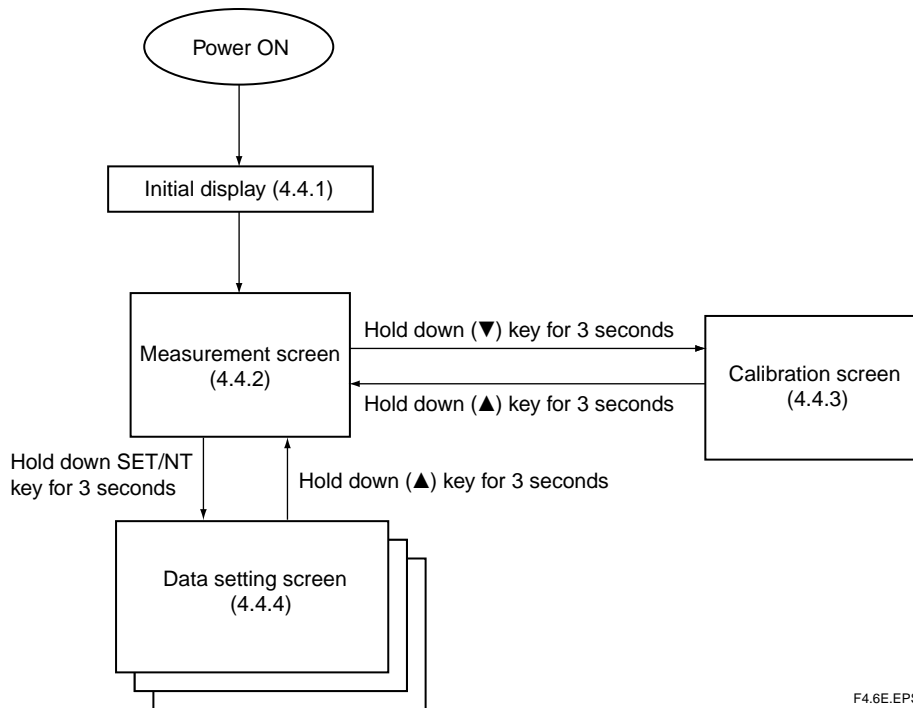

Fig. 4.6

4.4 Display Screen Examples

4.4.1 Initial display

- Display when the converter is normal
- 1) All LEDs are lit when the converter is powered on.
 - 2) Then all LEDs turn off.



Fig. 4.7 All LEDs lit

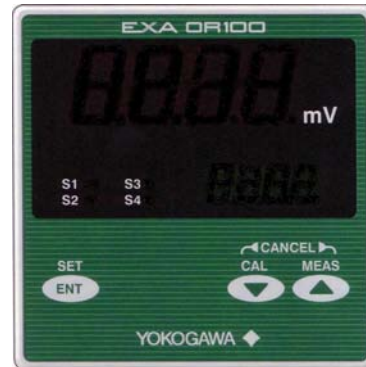

Fig. 4.8 All LEDs off

- 3) Then the measurement screen appears.



Fig. 4.9 Measurement screen

4.4.2 Measurement screen

- 1) Measurement screen
 - Measurement display: Displays ORP value. Integer display (-1500 to 1500)
 - Auxiliary display: Nothing is displayed during measurement.

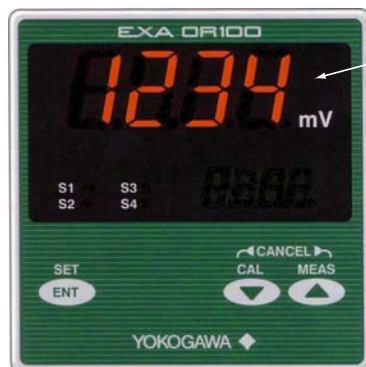

ORP display
Integer display: 4 digits
(-1500 to 1500)

Fig. 4.10 Measurement screen

F4.10E.EPS

4.4.3 Calibration screen

(1) Displaying measurement screen
 Hold down the ▼ key for 3 seconds to switch to the calibration screen.



Hold down this key for 3 seconds.
F4.11E.EPS

Fig. 4.11 Measurement screen

(2) Calibration screen



Fig. 4.12 Calibration screen

* Hold down the ▲ key for at least 3 seconds to return to the measurement screen.

4.4.4 Setting screen

(1) Measurement screen display
 Hold down SET/ENT key for at least 3 seconds to switch to data setting screen.



Hold down this key for 3 seconds.
F4.13E.EPS

Fig. 4.13 Measurement screen

* Hold down the ▲ key for at least 3 seconds to return to the measurement screen.

(2) Setting screen



Fig. 4.14 Setting screen

* Hold down the ▲ key for at least 3 seconds to return to the measurement screen.

5. Operation

5.1 Start up

5.1.1 Checking wiring

Check that all wiring connections have been properly completed (see Section 3.3).

5.1.2 Start up ORP converter

Apply power (specified on the instrument nameplate) to the OR100 Panel Mounted ORP Converter.

5.1.3 Data setting

Set the following parameters — (1) analog output parameters, (2) alarm parameters, and (3) other parameters — :

- (1) Analog output parameters
This screen is for user setting of analog output parameters.
- (2) Alarm parameters
This screen is for user setting of alarm parameters.
- (3) This screen is for user setting of measurement parameters other than (1) and (2) above.



NOTE

For key operations and LED display, see Section 4, "Overview of Operation Panel" and Table of LED display symbols, provided earlier in this manual.

(1) Analog output parameter setting screen (Ao.PA: displayed on the screen)

This screen is for user setting of analog output parameters. A list of menu options on the screen is shown below:

Table 5.1

Name	Parameter	Setting range	Default value	Note
Ao.PA	Menu title	Not applicable (NA)	NA	Set on a 100-mV basis
rL	Range low limit	-1500 to 1500 mV	-1500 mV	100 mV or greater (difference between high and low limit range)
rH	Range high limit	-1500 to 1500 mV	1500 mV	100 mV or greater
M.HLd	Hold during maintenance	0: No hold 1: Hold 2: Set value 1: Hold	1: Hold	
H.Ao	Hold output setting	2.0 to 20.8 mA	2.0	
F.HLd	Hold if abnormal	0: No hold 1: Burnout (2 mA)	1: Burnout (2 mA)	

T5.1E.EPS

Fig. 5.1 shows a flow chart for analog output parameter setting.

(2) Alarm parameter setting screen (Alrm displayed on the screen))

This screen is for user setting of alarm data. A list of menu options on this screen is shown below:

Table 5.2

Name	Parameter	Setting range	Default value	Note
Alrm	top menu	Not applicable (NA)	NA	
S1	S1	0: high-limit alarm 1: low-limit alarm 2: high-high limit alarm 3: low-low limit alarm 4: high-high limit/low-low limit alarm 5: abnormal	0: high-limit alarm	
HY1	S1 hysteresis	0 to 1000 mV	10 mV	On 1-mV basis
dLY1	S1 delay time	0 to 200 seconds	0	
S2	S2	0: high-limit alarm 1: low-limit alarm 2: high-high limit alarm 3: low-low limit alarm 4: high-high limit/low-low limit alarm 5: abnormal	1: low-limit alarm	
HY2	S2 hysteresis	0 to 1000 mV	10 mV	On 1-mV basis
dLY2	S2 delay time	0 to 200 seconds	0	
S3	S3	0: high-limit alarm 1: low-limit alarm 2: high-high limit alarm 3: low-low limit alarm 4: high-high limit/low-low limit alarm 5: abnormal	2: high-high limit alarm	When suffix code is -21, S3 does not appear.
HY3	S3 hysteresis	0 to 1000 mV	10 mV	When suffix code is -21, HY3 does not appear.
dLY3	S3 delay time	0 to 200 seconds	0	When suffix code is -21, dLY3 does not appear.
S4	S4	0: high-limit alarm 1: low-limit alarm 2: high-high limit alarm 3: low-low limit alarm 4: high-high limit/low-low limit alarm 5: abnormal	3: low-low limit alarm	When suffix code is -21, S4 does not appear.
HY4	S4 hysteresis	0 to 1000 mV	10 mV	When suffix code is -21, HY4 does not appear.
dLY4	S4 delay time	0 to 200 seconds	0	When suffix code is -21, dLY4 does not appear.
H.A	High-limit alarm	-1500 to 1500 mV	1500 mV	On a 10-mV basis
L.A	Low-limit alarm	-1500 to 1500 mV	-1500 mV	On a 10-mV basis
HH.A	High-high limit alarm	-1500 to 1500 mV	1500 mV	On a 10-mV basis
LL.A	Low-low limit alarm	-1500 to 1500 mV	-1500 mV	On a 10-mV basis

T5.2E.EPS

A flow chart for setting alarm parameters is shown below.
 For four contact outputs:

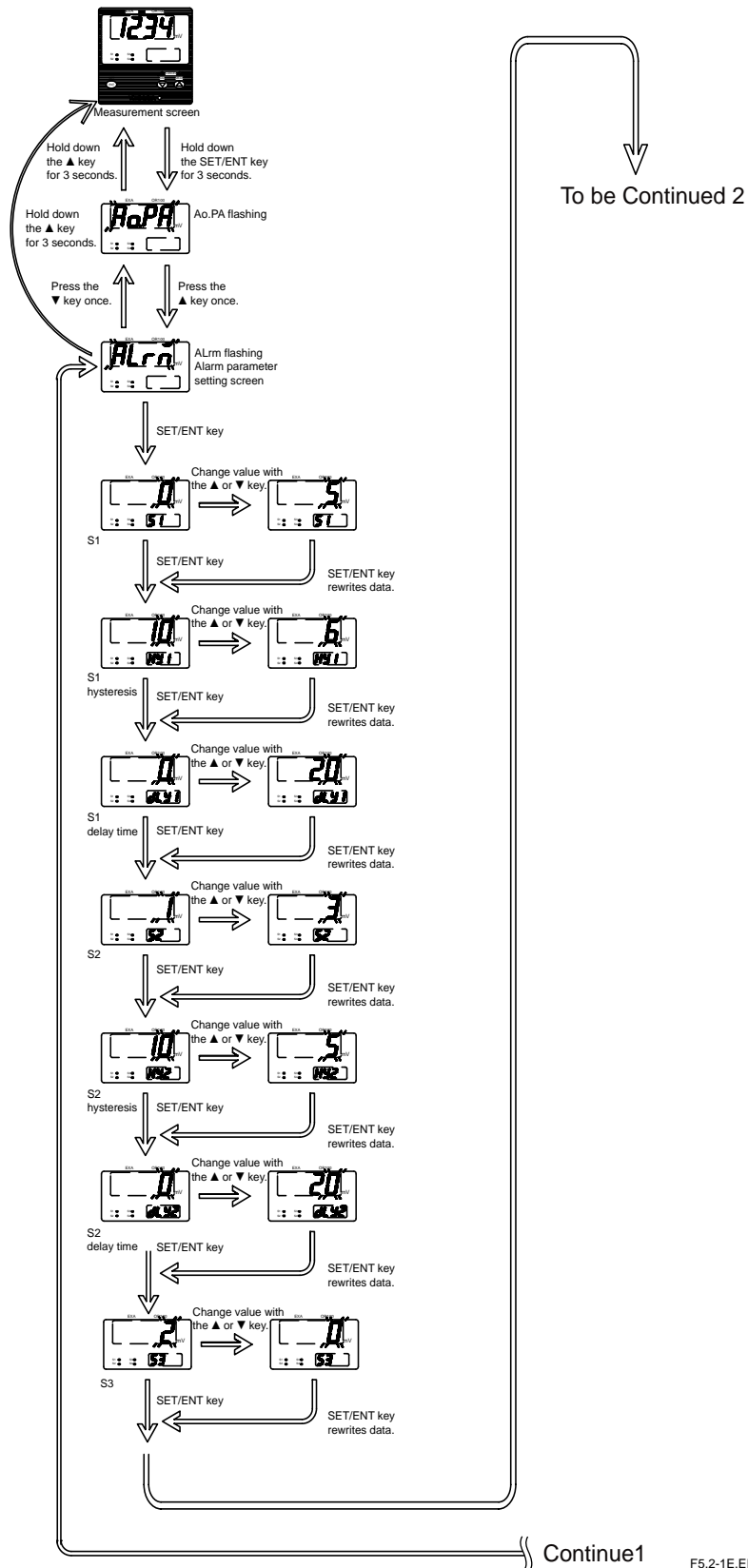

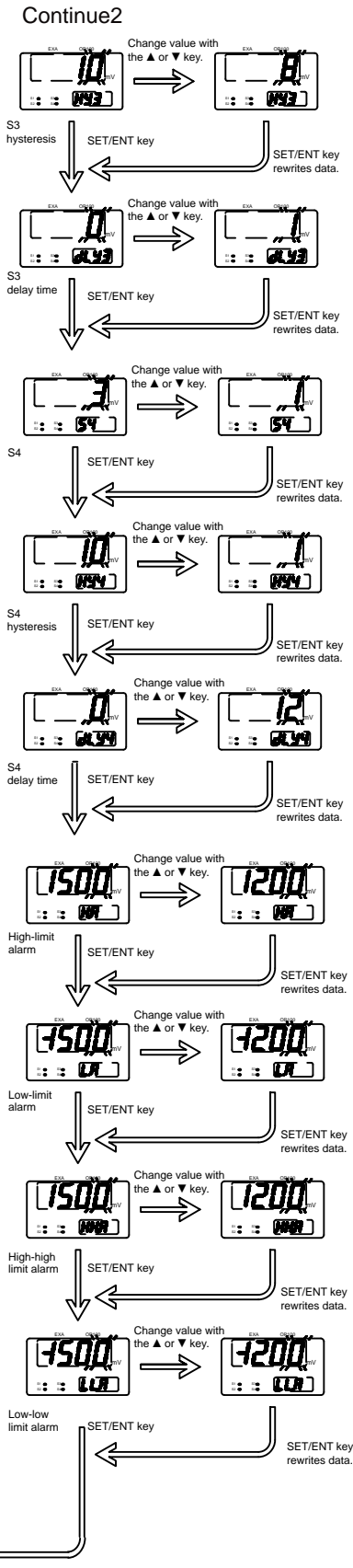

F5.2-2E.EPS

Fig. 5.2 Flow chart for setting alarm parameters

* To cancel the alarm parameter setting, press both ▼ and ▲ keys simultaneously.

(3) **Other parameter setting screen (otHr displayed on the screen)**

This screen is for user setting of parameters for other measurements. A list of menu options for this screen is shown below.

Table 5.3

Name	Parameter	Setting range	Default value	Note
otHr	Menu title	Not applicable (NA)	NA	
CHK	Measured value checks	No checks	No checks	Displays the current mV values.
d.InS	InSP menu display flag setting	0: No display 1: Display	0: No display	Always set to 0 (zero). When the power is turned off, set value will be 0 (zero).

 For use by factory authorized personnel only

T5.3E.EPS

An example of setting other measurement parameters is flowcharted below:

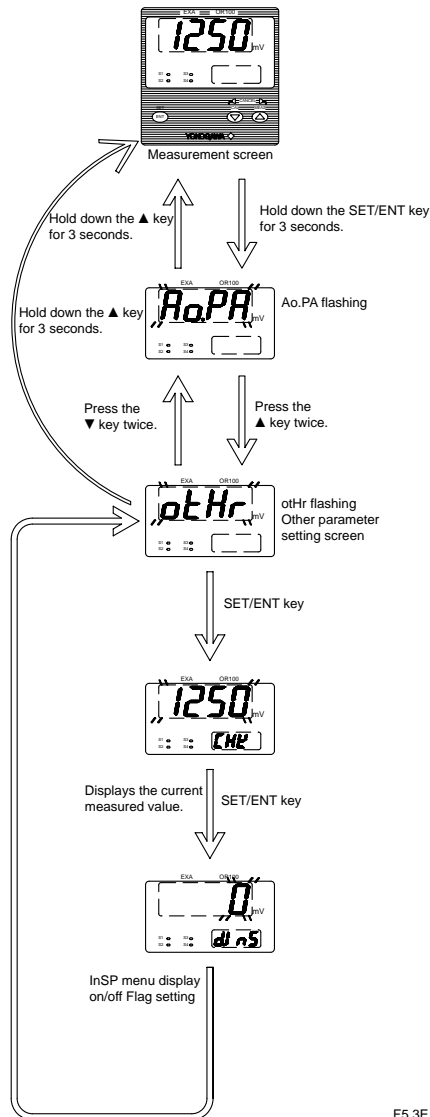

F5.3E.EPS

Fig. 5.3

* To cancel the alarm parameter setting, press both ▼ and ▲ keys simultaneously.

6. Sensor Check and Calibration Procedures

Dirt attached to the liquid junction or sensitive parts (platinum electrodes) may have an adverse effect on electromotive force and response characteristics, so ORP sensors require periodic cleaning for good operating conditions. ORP sensors should be checked and calibrated if the following conditions are met.

(1) Sensor checks

- If a new ORP sensor is used or the existing sensor has been unused for an extended period of time.
- When an ORP sensor sensitive part (platinum electrode) or a liquid junction is cleaned.

(2) Calibration

- If sensor electromotive force is outside the allowable ranges.
- If the measured value by the ORP sensor is adjusted to the measured value by other sensors.

6.1 Overview of Sensor Checks and Calibration

6.1.1 Sensor checks

A standard solution with known Oxidation-Reduction Potential should be measured. Check that the measured value is within the allowable range. The sensor shall be checked in the measurement mode.

6.1.2 Calibration (manual calibration)

Use a solution with ORP values to calibrate that the ORP sensor for OR100 indicates those values. During manual calibration, the measured value of the ORP sensor for OR100 is adjusted to the known value. This calibration procedure is also used where sensor check results are somewhat outside the allowable ranges. For more details, see Section 6.3, later in this manual.

6.1.3 Sensor check solution

Use a Quinhydrone solution or iron solution for sensor checking.

6.2 Checking Sensors

6.2.1 Preliminary

- (1) Rinse the ORP sensor sensitive part and any grime with clean water.
- (2) Preparation for sensor check solution*.

*

If you do not have any suitable check solution, use Quinhydrone reagent (or iron reagent) and follow the instructions below for preparation of a check solution.

Procedures for making sensor check solutions

[Quinhydrone solution]

Put one bag reagent into the 250-ml wide-mouth bottle. Pour pure water in the bottle and dissolve it to a 250-ml solution. If pure-water temperature is low, the reagent may not dissolve completely and some reagent may be floating, but no problems occur in actual use.

[Iron solution]

Put both light purple and light green reagents (one bag each) used for a preparation into a 250-ml wide-mouth bottle. Dissolve these reagents with 2 mol/l sulfuric acid to be the total amount of 250 ml.

If concentrated sulfuric acid is used for preparation, first pour pure water into a wide-mouth bottle containing reagents and, while stirring these reagents, pour concentrated sulfuric acid of 14 ml into the bottle and then dissolve reagents with pure water to be a 250-ml solution.

NOTE

The company supplies reagents for Quinhydrone solution, part number K9024EC. You can purchase reagents for iron solution, part number K9024ED. Concentrated sulfuric acid should be arranged by the customer.

WARNING

Care shall be taken in handling concentrated sulfuric acid when preparing a solution.

Figure 6.1 shows allowable ranges (voltage ranges indicated by a normal ORP sensor) of oxidation-reduction potential (ORP) of Quinhydrone and iron solutions.

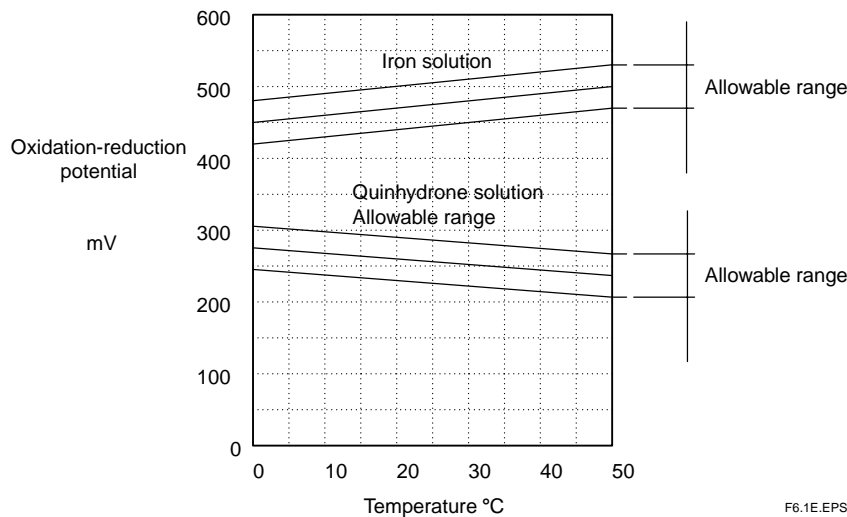

Fig. 6.1

6.2.2 Checking sensors

Display the CHK on the other parameter setting screen to check the ORP sensor.

Note: This will place the 4-20mA in hold.

- (1) Immerse the ORP sensor in the checking solution.
- (2) Read a displayed value.

Note: Allow a sensor value to be stabilized, and then read a displayed value.

Note: If the displayed value is outside the allowable range, conduct a manual calibration by referring to Section 6.3, later in this manual.

6.3 Manual Calibration

6.3.1 Preliminary

Rinse the ORP sensor sensitive part and any grime with clean water.

Note: Follow the instructions below for sample extraction.

- If the OR100 measurements cannot be compared with the standard measured values by the ORP meter in real time, sampling should be conducted immediately before the calibration, or a larger number of samples should be extracted to prevent ORP values from being changed with temperature change, or the like.
- Sample a solution indicating an ORP value as remote as possible from 0 mV within the measurable range.

 **NOTE**

Use our portable ORP meter calibrated with a standard ORP meter. A calibration adjustment should be made with the values displayed by this ORP meter.

6.3.2 Manual calibration procedures

To conduct manual calibration, follow these instructions:

- 1) Hold down the ▼ key on the measurement screen for 3 seconds to switch to the manual calibration screen displaying “CAL” in the auxiliary display area.
- 2) Immerse the ORP sensor in a solution with known ORP values.
- 3) Press the SET/ENT key to flash CAL in the auxiliary display area. (Flashing the CAL implies that the calibration is started.)
- 4) Press the SET/ENT key to flash a measured value in the measurement display area. CAL is displayed in the auxiliary display area.
- 5) Allow the measured value to be stabilized. Press the SET/ENT key. The least significant digit of the measured values flashes in the measurement display area. CAL is displayed in the auxiliary display area.
- 6) Set the calibrated values with the ▲ and ▼ keys.
- 7) Press the SET/ENT key to stop flashing in the measurement display area. “Ent1” flashes in the auxiliary display area. At this time, the calibrated data are effective in the measured value. If recalibration is to be made in the same solution, press the ▲ and ▼ keys simultaneously.
- 8) To ensure the calibrated data, press the SET/ENT key. “Good” is flashed in the auxiliary display area. The calibration results are written to the EEPROM.
- 9) Press the SET/ENT key to return to the CAL display.
- 10) The ORP sensor is returned to the process. Hold down the ▲ key for at least 3 seconds to return to the measurement screen.

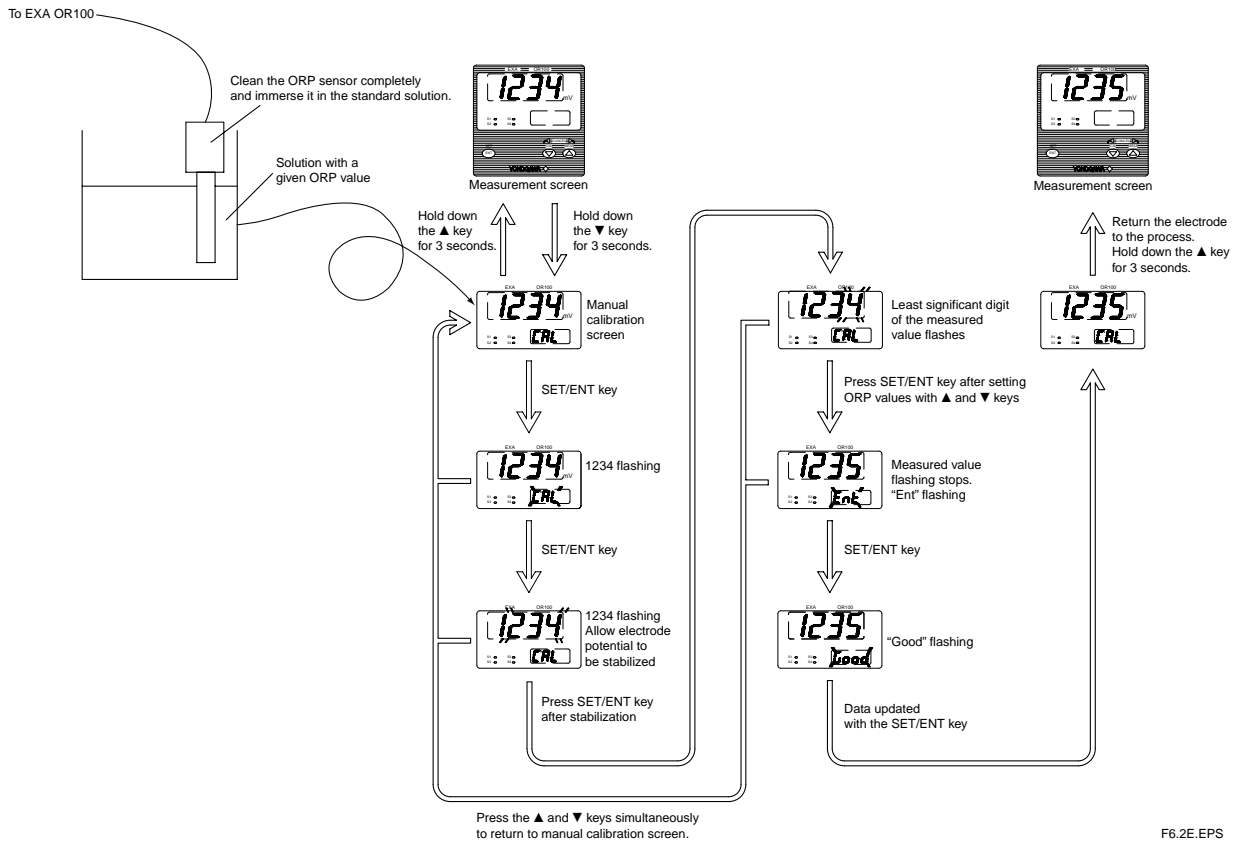

Fig. 6.1

F6.2E.EPS

6.4 Canceling Calibration

To cancel the calibration:

- 1) Press the ▲ and ▼ keys simultaneously several times until the first calibration screen (CAL display in the auxiliary display area) appears. At this time, the calibration results are not updated.
- 2) Restore the sensor to the process and hold down the ▲ key for at least 3 seconds to return to the measurement screen.

6.5 If an Error Occurs during Calibration

If the zero offset is outside the range -500 mV to 500 mV, a calibration error will result. Measured values are displayed in the measured value display area and an error code flashes in the auxiliary display area. No calibrated results are updated.

(For more details on error codes, see Tables 8.1 and 8.2, later in this manual.)



NOTE

Key entries are accepted only when the ▲ and ▼ keys are pressed simultaneously on both the auto-calibration screen and manual calibration screen.

6.5.1 Recovering from an Error

To make a recalibration:

- 1) Press the ▲ and ▼ keys simultaneously several times until the first calibration screen appears.
- 2) Press the SET/ENT key. Then you can perform calibration work again.

6.5.2 Quitting calibration screen

- 1) Press the ▲ and ▼ key simultaneously to return to the first calibration screen.
- 2) Hold down the ▲ key for at least 3 seconds to return to the measurement screen



NOTE

Be sure to restore the sensor to the process before pressing the keys.

7. Maintenance and Cleaning

7.1 Periodic Maintenance

7.1.1 Sensor cleaning

When the platinum electrode or liquid junction of the ORP sensor becomes dirty, the measured value may be unstable or drift, and response may become very slow. To avoid this, clean the sensor periodically.

7.1.2 Checking the KCl solution for ORP sensor

If KCl refillable ORP sensors are used, replenish KCl solutions periodically.



NOTE

Refer to applicable ORP sensor instruction manuals for replenishing KCl solutions.

7.2 Preventive Maintenance

7.2.1 ORP converter terminal isolation

ORP sensor input terminals shall be isolated with each other with a high resistance. Check the sensor terminals once or twice a year to confirm that they are not dirty, and have not been affected by condensation.

7.2.2 Checking ORP sensor displays

Use soft cloth or tissue paper to clean off any dirt on the displays of the OR100 ORP converter. If required, you may use neutral detergent to remove dirt, but avoid using organic solvents.

8. Troubleshooting

8.1 Unexpected Value Displayed (Pinpointing the Causes of Problems with Converter or Sensor)

A. If unexpected values are displayed

Step 1:

- Check the KCl level in the sensor.

Step 2:

- Check if the sensor electrode is dirty.

If dirty, follow these steps to clean the electrode:

- (1) Use clean water to wash the ORP electrode, reference electrode, and liquid junction.
- (2) If any stain does not wash off, use a cotton-tipped swab.
- (3) Chemical (metallic) stain may be removed by immersing in a solution containing dilute hydrochloric acid of approximately 1N for several minutes, then washing off with clean water.

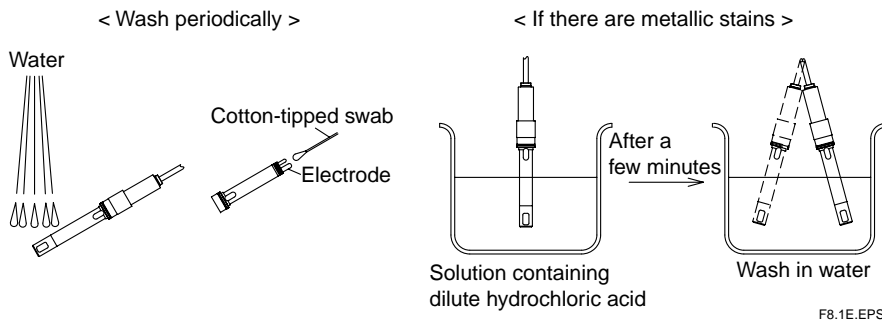

Step 3:

- Use the standard solution or a special solution for calibration.

Case 1: Though the calibration is made normally, but a displayed value is still abnormal, the electrode may be degraded.

Case 2: If no errors occur and calibration does not end normally, refer to B below.

Case 3: If error occur during calibration, refer to C below.

B. If the calibration is not being conducted normally.

- (1) Use a new standard calibration solution.
- (2) Repeat Steps 1 and 2 in A above.
- (3) If things do not proceed normally even if the calibration is conducted again.

The existing electrode may be degraded. Prepare a new sensor.

If an error occurs during calibration:

Follow the flowchart instructions below. Refer to Section 8.2, "Displaying Errors," later in this manual.

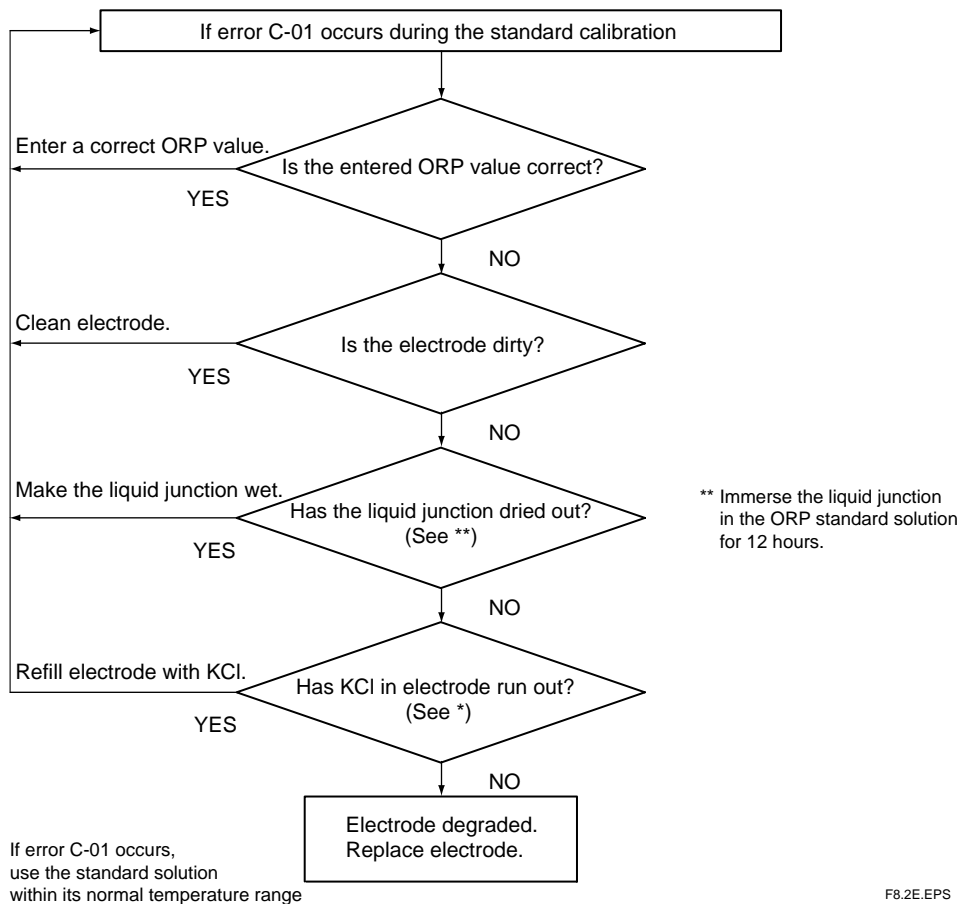

C. If an error occurs during measurement:

Follow the procedures shown in the flowchart below.
Refer to Section 8.2, "Displaying Errors," later in this manual.

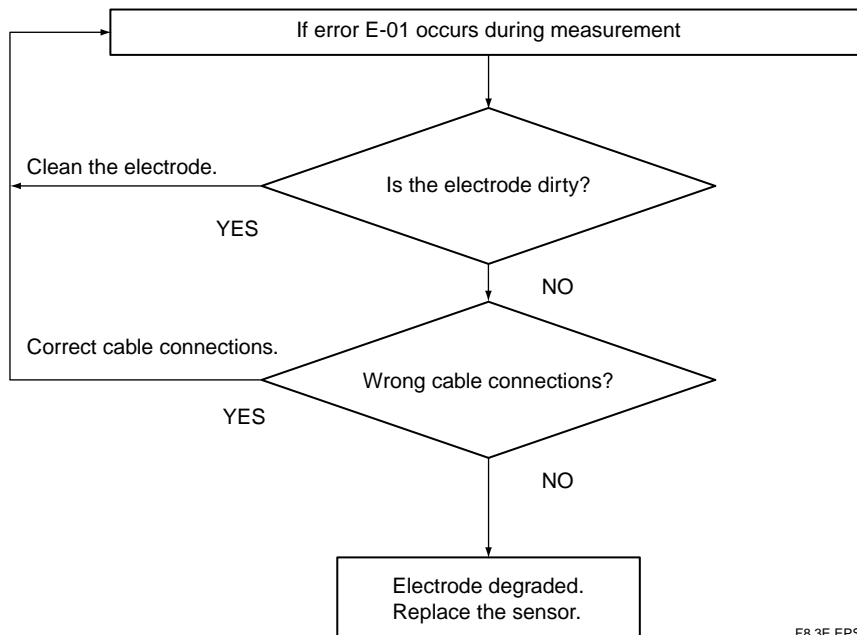

D. If replacing sensor does not revert to normal:

- The converter may be defective.

E. Error E-04 occurs.

- The converter may be defective.

8.2 Displaying Errors

If the OR100 converter detects any problem, an error (with error code flashing) is displayed in the message area. If an FAIL contact output has been set, the corresponding contact is closed to indicate that the OR100 converter is defective. In addition, if output hold options are specified, the converter output is kept at 2 mA (burnout downscale action). Error numbers and error details are shown below.

Table 8.1

Error number	Auxiliary display	Error detail
1	E-01	ORP measurement out of range
4	E-04	Converter defective

T8.1E.EPS

Table 8.2

Calibration error number	Auxiliary display	Error detail
1	C-01	Asymmetry potential error

T8.2E.EPS

For error code details, see Section 8.3.

8.3 Checks and Corrective Action

If an error occurs, check the cause of error according to the error number and take corrective action. Error numbers do not disappear unless otherwise the causes of error are removed.

8.3.1 ORP measurement out of range

Auxiliary display: E-01

[Cause]

The ORP measurement is outside the ORP measurement range -1500 to 1500 mV.

[Corrective action]

- (1) Check electrical connections between the ORP sensor and converter.
- (2) Check for disconnected ORP sensor cables.
- (3) Check for dirty liquid junction. Check for defective electrode part.
- (4) If a defective ORP sensor is found, replace the ORP sensor with a new one.

8.3.2 Converter defective

Auxiliary display: E-04

[Cause]

Converter defective

[Corrective action]

Turn the power OFF and ON. If error code E-04 is displayed, contact the company.

8.3.3 Calibration asymmetry potential error

Auxiliary display: C-01

[Cause]

If asymmetry potential is outside the range -500 mV to 500 mV, a calibration error occurs.

[Corrective action]

- (1) The entered ORP values are not correct.
- (2) Check for dirty ORP sensor or liquid junction. If it is dirty, clean the electrode.
- (3) The ORP sensor may be degraded.
- (4) If the ORP sensor is defective, replace the ORP sensor.

Customer Maintenance Parts List

Model OR100 Panel Mount ORP Converter

EXA OR

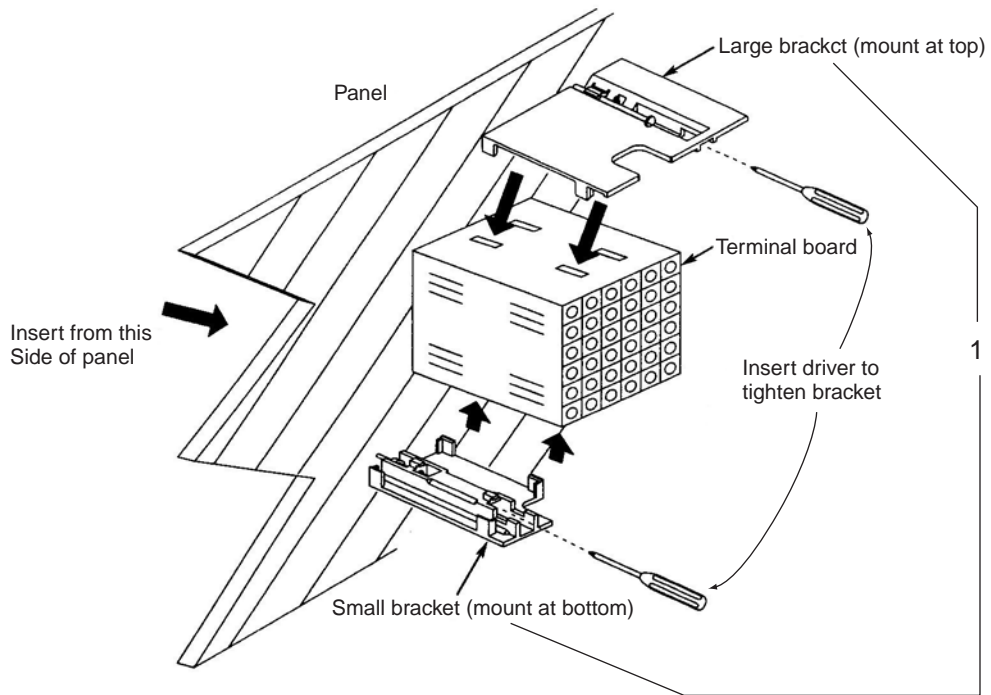

Item	Part No.	Qty	Description
1	T9115NL	1	Mount assembly

Revision Record

Manual Title : Model OR100 Panel Mount ORP Converter

Manual Number : IM 12C11A01-01E

Edition	Date	Remark (s)
1st	May. 2003	Newly published
2nd	Mar. 2004	US modifications
3rd	May 2004	UL, CSA, EMC standards added
4th	Oct. 2008	UL, CSA, EMC, C-tick standard deleted, because out of certifications Page 1-3 Section 1.4 Standard Specification, Installation altitude deleted, Safety and EMC copmpliance deleted, because out of certifications; Page 3-9 Section 3.8 Power and Ground Wiring, Note for power on-off switch modified. CMPL 12C11A01-01E added.
