

Oxidation Monitoring in the Cyanide Wastewater Treatment Process

Industry: Electrical and Electronics
Product: pH/ORP Analyzer

Introduction

Cyanide-bearing wastewater from mining and electroplating facilities and certain types of chemical plants is toxic and must be treated by oxidation with chlorine or chloride to bring the cyanide concentration within regulatory limits. The waste materials contain alkaline, rare earth metals, and other heavy metals such as iron, nickel, zinc, cadmium, copper, silver and gold. As well as sometimes can contain the deadly poison, cyanide. As the speed of the oxidation reaction is closely tied to the pH value, a pH analyzer is used together with an

ORP (oxidation-reduction potential) analyzer to monitor the completion of the reaction. The use of these analyzers also ensures that excessive amounts of chemicals (e.g., chlorine) are not used to produce the reaction. Both 2-wire and 4-wire analyzers are suitable for this measurement system. A gold electrode should be used for ORP measurement of cyanide-containing solutions.

Expected Benefits

- Measures pH/ORP of cyanide wastewater continuously
- Reduces operating costs

Process Overview

Cyanide decomposition takes place in two stages. In the primary reaction, cyanide is oxidized to cyanate under high alkaline conditions (high pH and ORP). In the first reaction tank, the pH of the waste is measured and caustic (NaOH at 50% strength) is injected to raise the pH to 10 or higher. The oxidation reduction potential (ORP) of the waste is measured, and chlorine gas (Cl₂) is automatically injected to raise the ORP to 400 mV or higher. The reaction normally occurs within 5 to 10 minutes. In the secondary reaction, the cyanate is further oxidized under near-neutral conditions and converted to harmless carbon dioxide and nitrogen gases. In the second reaction tank, the pH of the waste is measured, and acid is injected to lower pH to 7-8. This process takes 2 to 5 minutes. In the third reaction tank, the ORP of the waste is measured and chlorine gas (Cl₂) is automatically injected to raise the ORP to 600 mV or higher (Meanwhile the pH controller maintains the set-point at 7-8, correcting for any acidity created by the addition of the chlorine gas). This reaction occurs, taking 10 to 15 minutes, then the cyanide is eventually converted to harmless materials by the above reaction and the waste can be discharged.

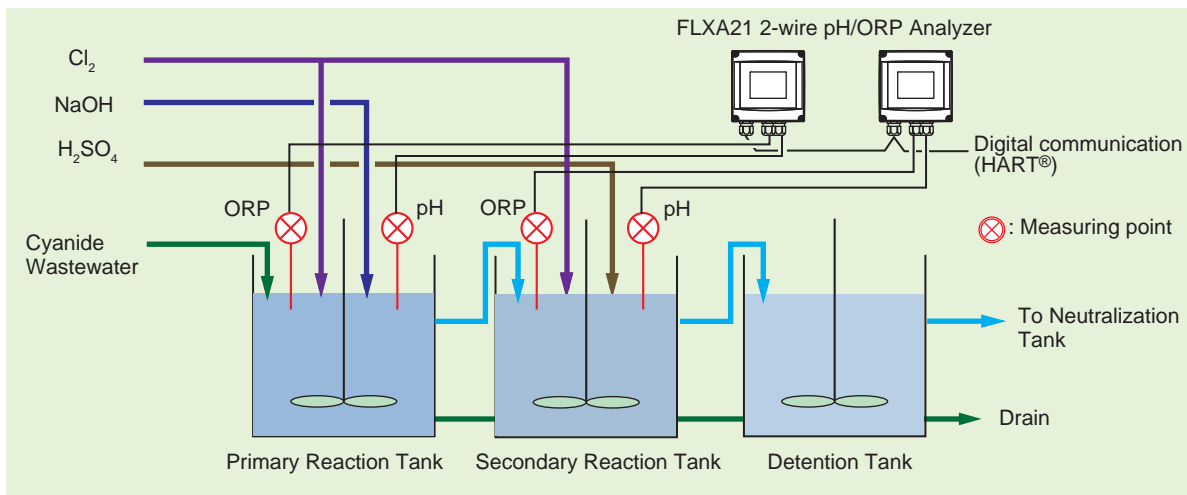

	Primary reaction	Secondary reaction
Chemical reaction	$\text{NaCN} + \text{Cl}_2 + 2\text{NaOH} \rightarrow \text{NaCNO} + 2\text{NaCl} + \text{H}_2\text{O}$	$2\text{NaCNO} + 4\text{NaOH} + 3\text{Cl}_2 \rightarrow 2\text{CO}_2 + 6\text{NaCl} + \text{N}_2 + 2\text{H}_2\text{O}$
pH value	10 < pH < 11	7.5 < pH < 8.5
ORP value	Approx. 300 to 350 mV	Approx. 600 to 650 mV

Solution Details

Measurement system

2-wire/4-wire pH/ORP measurement system

Sensor/Holder

KCl refillable ORP sensor

OR8EFG-AU-□□-TT1-□*A

KCl refillable pH sensor

PH8EFP-□□-TN-TT1-N-□*A

Submersion type holder

PH8HS-PP-□□-T-NN-NN*A

Terminal box (when needed)

WTB10-PH5 (for 2-wire system)

WTB10-PH3 (for 4-wire system)

Analyzer/converter

2-wire pH/ORP analyzer (pH+ORP 2 input)

FLXA21-D-P-S-AA-P1-P1-A-N-LA-N

Distributor (for 2-wire system)

PH201G- A□*B

4-wire pH/ORP converter

PH450G-A-□

Utilities

FLXA21

Power supply: 23 to 40 V DC (from distributor)

PH201G distributor (for 2-wire system)

Power supply: 100 V: 20 to 130 V DC/80 to 138 V AC, 47 to 63 Hz
220 V: 120 to 340 V DC/138 to 264 V AC, 47 to 63 Hz

Power consumption: 24 V DC: approx. 200 mA
100 V AC: approx. 7 VA
220 V AC: approx. 11 VA

PH450G

Power supply: 90 to 264 V AC, 50/60 Hz

Power consumption: approx. 15 VA

Measurement Conditions

1. Cyanide curve measured with chlorine

[Measurement of water with a pH value of 9 using a gold electrode (as the indicating electrode) and an Ag/AgCl electrode with 4 mol (as the reference electrode)]

Oxidation reaction of CN^- with Cl_2 exhibits a characteristic curve that is not ideal (see the figure on the right). This is because firstly an excessive amount of chlorine increased the plateau potential of the intermediate, cyanogen chloride to 500 to 600 mV, and secondly oxidation reaction started in the secondary reaction tank to form CNO^- , resulting in a decrease in ClO^- and stopping the potential from increasing.

2. Using a gold electrode as the indicating electrode for ORP measurement

A gold electrode should be used to ensure accurate measurement of ORP in cyanide solutions. When the potential is near or under 200 mV during the cyanide oxidation process, a platinum electrode produces a catalytic reaction that causes hydrogen to form on the electrode surface. This generates potential and affects measured values.

