

Humidity Measurement for Paper Dryer Control

Industry: Pulp and Paper
Product: Zirconia Humidity Analyzer

Introduction

Drying is an important part of the papermaking process that evaporates the remaining water in the wet paper web. This is performed with a dryer, and the humidity control in this dryer is essential to maintaining high paper quality (e.g., strength, paper surface) and high heat energy efficiency.

The ZR402G/HS Direct In Situ Zirconia High Temperature Humidity Analyzer requires no sampling system and operates stably in high-temperature environments. It has been well received in the marketplace.

Expected Benefits

- Increases the heat energy efficiency of the dryer in the papermaking process
- Ensures high paper quality
- Reduces operating costs

Process Overview

The pulp suspension is dispersed uniformly, dewatered, and pressed to produce wet paper, the moisture content of which is approximately 20 to 50%. The remaining water is removed by evaporation. This is achieved by passing the sheet through a steam-heated roll in a closed dryer. The water is evaporated by recirculating hot (50 to 120 °C), low-humidity air through the dryer. To maintain the specified humidity, humidity meters are installed at several locations in the dryer.

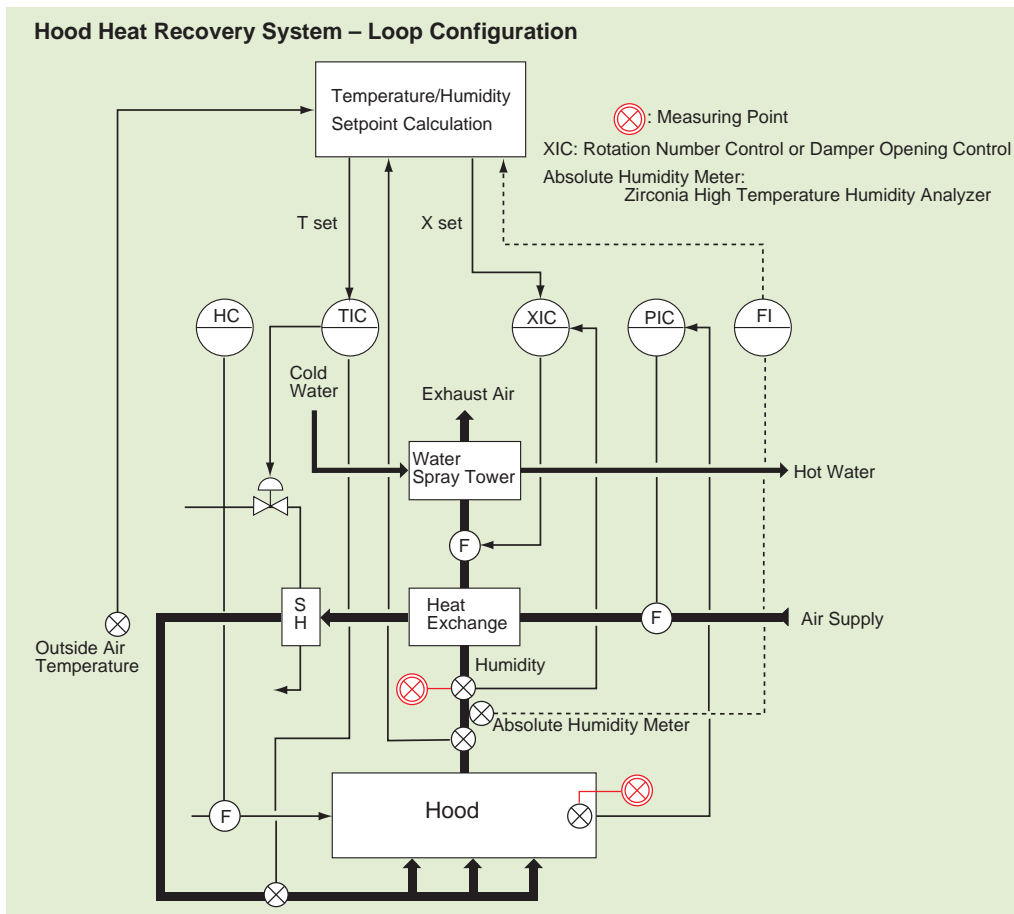

Solution Details

Field Data

Process conditions

Measurement point:	Closed (semi-closed) hood or exhaust duct of hood with humidistat control
Temperature:	50 to 120 °C
Pressure:	Negative
Dust:	Trace amounts (paper dust)

Measurement system

Detector:

ZR22G-040-S-C-E-□-□-E-A/□

Dust protector:

ZH21B-040-A*B

Converter:

ZR402G-□-E-E-A/HS/□

Flow setting unit:

ZA8F-A*C/Z Z: with dehumidifier (when needed)

Calibration gas unit:

Pressure regulator for gas cylinder:

P/N G7013XF (inlet W22, outlet Rc1/4) or P/N G7014XF (inlet W22, outlet 1/4NPT)

Case assembly for calibration gas cylinder: P/N E7044KF

Note: the calibration gas cylinder must be purchased locally

Utilities

Power supply:	rated voltage: 100 to 240 V AC
	operating voltage range: 85 to 264 V AC
	rated frequency: 50/60 Hz
operating frequency range: 45 to 66 Hz	

Power consumption: approx. 100 VA (300 VA max.)

Instrument air (reference gas): pressure: 300 to 700 kPa

Notes

- The humidity measurement system introduced here can also be used in dryers in the flour and starch making processes.

Notes on Installation

- The sensor is hot. To remove a possible ignition source, a dust protector should be used to prevent suspended paper dust from coming into contact with the sensor.
- Since the process humidity is low, the humidity of the reference air greatly affects the accuracy. Clean, dry air such as instrument air should be used as the reference air. If such air is not available, a customized flow setting unit with a dehumidifier should be used.

Note on dew points of instrument air or air from flow setting unit with dehumidifier:

Instrument air: -18 to -9 °C (0.1236 to 0.2823 vol% H_2O)

Air at outlet of flow setting unit with dehumidifier:

1 to 2 ±0.1 °C (0.6479 to 0.6962 vol% H_2O)

