

## Selection of Sensor Holders for Liquid Analyzers Used in a Batch Sewage Treatment System

**Industry:** Wastewater  
**Product:** Liquid Analyzers

### Introduction

In a batch tank, analyzers such as dissolved oxygen (DO) analyzers, oxidation-reduction potential (ORP) meters, and mixed liquor suspended solid (MLSS) analyzers are used. To reduce the maintenance frequency, measures must be taken to prevent dirt accumulation on the sensor. As the liquid level in a tank can vary greatly, great care should be taken when selecting the sensor installation position in a tank.

### Expected Benefits

- Ensures stable, continuous measurement in heavily contaminated liquid
- Reduces operating costs
- Eliminates the need for manual cleaning

### Process Overview

The batch treatment method is an intermittent sewage treatment method where a sequential process of sewage intake, aeration, settling, and drainage is performed repeatedly in a single reaction tank (batch tank). Characteristics of this method include:

- Stable treatment even if the sewage volume changes
- Compact facilities: requiring no settling tanks
- Removal of not only organic matter but also nitrogen and phosphorus

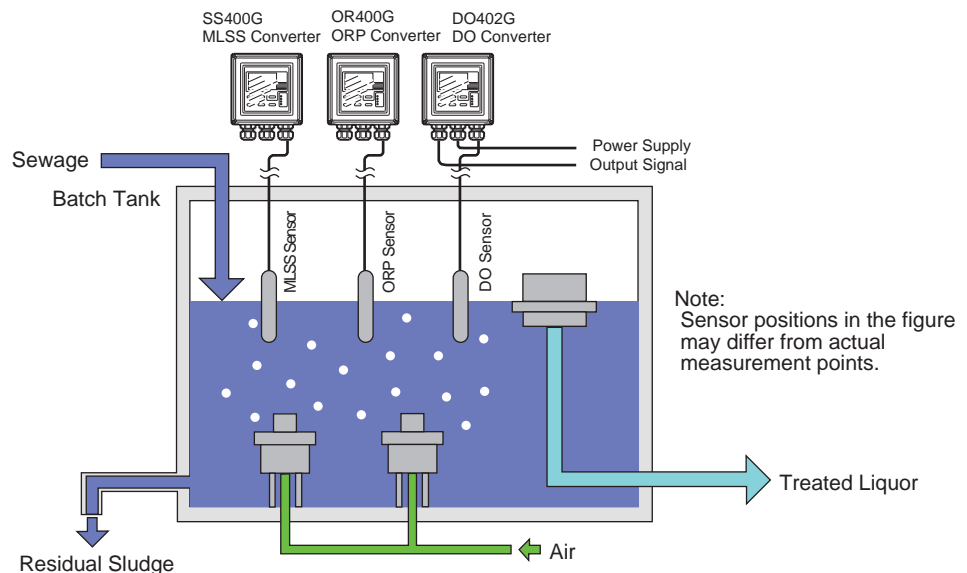

### Field Data

Cleaning effectiveness testing of DO analyzer

Output signal comparison between no cleaning and water jet cleaning

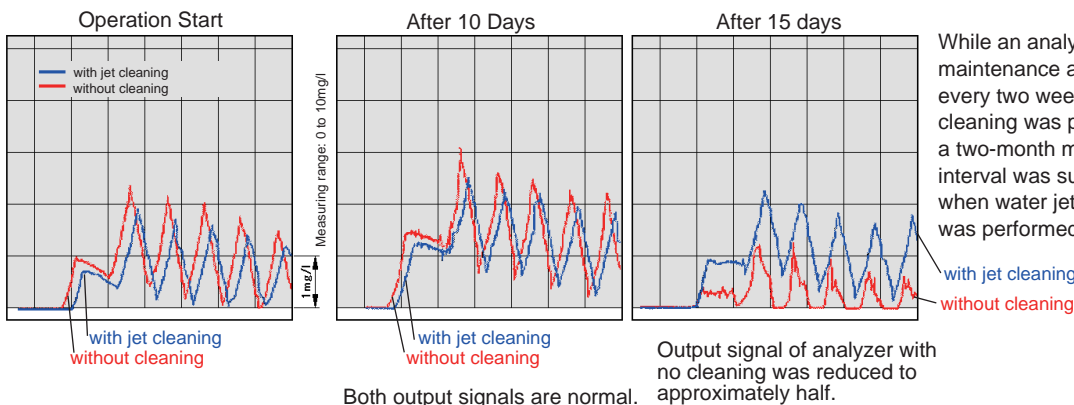

While an analyzer required maintenance approximately every two weeks when no cleaning was performed, a two-month maintenance interval was sufficient when water jet cleaning was performed.

Both output signals are normal.

**Solution Details (Holder List)**

<p align="center"><b>DO402 Dissolved Oxygen Analyzer</b></p> <p>Typical DO sensor holders that are suited for batch tanks include the guide pipe type with water jet cleaner (custom-ordered), vertical floating type, and guide pipe type. The guide pipe type with water jet cleaner and vertical floating types have excellent maintainability. For a batch tank with a lid, the vertical floating type should be used.</p>		
<p><b>Guide Pipe Type with Water Jet Cleaner</b></p>	<p><b>Vertical Floating Type</b></p>	<p><b>Guide Pipe Type</b></p>
<p><b>Configuration Components</b></p> <ul style="list-style-type: none"> <li>• DO sensor: DO30G-NN-50-□□-PN</li> <li>• Holder: Custom-ordered</li> <li>• Converter: DO402G-1-□-E</li> <li>• Solenoid valve: PH8MV-W-□□-□0°C</li> </ul>	<p><b>Configuration Components</b></p> <ul style="list-style-type: none"> <li>• DO sensor: DO30G-NN-50-□□-PN</li> <li>• Holder: PB360G-PV-□5-NN</li> <li>• Converter: DO402G-1-□-E</li> </ul>	<p><b>Configuration Components</b></p> <ul style="list-style-type: none"> <li>• DO sensor: DO30G-NN-50-□□-PN</li> <li>• Holder: PH8HG-PV*A</li> <li>• Converter: DO402G-1-□-E</li> </ul>
<p align="center"><b>OR400 ORP Analyzer</b></p> <p>Typical ORP sensor holders suited for batch tanks are a guide pipe type with water jet cleaner (custom-ordered) and an immersion type.</p>		<p align="center"><b>SS400 MLSS Analyzer</b></p> <p>Typical MLSS sensor holders suited for batch tanks are a suspension type with jet cleaner and a vertical floating type.</p>
<p><b>Guide Pipe Type with Water Jet Cleaner</b></p>	<p><b>Immersion Type</b></p>	<p><b>Suspension Type with Jet Cleaner</b></p>
<p><b>Configuration Components</b></p> <ul style="list-style-type: none"> <li>• ORP sensor: OR8EFG-AU-□□-TT1-N*A</li> <li>• Holder: Custom-ordered</li> <li>• Converter: OR400G-□-E</li> <li>• Solenoid valve: PH8MV-W-□□-□0°C</li> </ul>	<p><b>Configuration Components</b></p> <ul style="list-style-type: none"> <li>• ORP sensor: OR8EFG-AU-□□-TT1-N*A</li> <li>• Holder: PH8HS-PP-□□-T-NN-NN*A</li> <li>• Converter: OR400G-□-E</li> </ul>	<p><b>Configuration Components</b></p> <ul style="list-style-type: none"> <li>• MLSS detector: SS300G-NN-□□-PN/JTJ</li> <li>• Holder: HH350G-NN-□0-JT-JP</li> <li>• Converter: SS400G-N-□-E</li> </ul>