

General Specifications

Model YTA80 Temperature Transmitter

YTA SERIES

The YTA80 is a head mount type of temperature transmitter that accepts thermocouple, RTD, ohms or DC millivolts input and converts it to digital communication signal based on FOUNDATION™ Fieldbus protocol. The YTA80 conforms to the standard DIN formB head mounting.

Common specifications:

Supply voltage, DC: Standard, YTA80/KN2.....	9 – 32V
ATEX, YTA80/KS2	9 – 30V
In FISCO installations	9 – 17.5V
Consumption	< 11mA
Max.current increase in the event of an error	< 7mA
Isolation voltage, test	1.5kVAC for 60sec
Isolation voltage, operation.....	50VRMS/75VDC
Warm-up time	30sec
Signal/noise ratio	min.60dB
Response time (programmable)	1 – 60 sec
Updating time	< 400ms
Execution time, PID controller.....	< 200msec
Execution time, analogue input.....	< 50msec
Signal dynamics, input.....	24 bit
Calibration temperature	20 – 28°C
Ambient temperature limits (Option code may affects limit)	-40°C to +85°C
Vibration.....	IEC 60068-2-6 and IEC60068-2-64
Lloyd's specification no.1	4g/2 – 100Hz
Humidity.....	< 95%RH (non-cond.)
Dimensions.....	ø44 x 20.2mm
Tightness (enclosure / terminal).....	IP68/IP00
Weight.....	55g

Electrical specs, RTD and linear resistance input:

RTD type	Min. Value	Max. Value	Norm
Pt25 - Pt1000	-200°C	+850°C	IEC60751/JIS C1604
Ni25 - Ni1000	-60°C	+250°C	DIN43760
Cu10 - Cu1000	-50°C	+200°C	$\alpha = 0.00427$
Lin.resistance	0 Ω	10kΩ	-
Potentiometer	0 Ω	100kΩ	-

Cable resistance per wire	50Ω
Sensor current.....	Nom. 0.2mA
Effect of sensor cable resistance (3-/4-wire).....	< 0.002Ω/Ω
Sensor error detection	Yes
Short circuit detection	< 15Ω

TC input:

Type	Min. value	Max. value	Norm
B	+400°C	+1820°C	IEC60584-1
E	-100°C	+1000°C	IEC60584-1
J	-100°C	+1200°C	IEC60584-1
K	-180°C	+1372°C	IEC60584-1
L	-200°C	+900°C	DIN 43710
N	-180°C	+1300°C	IEC60584-1
R	-50°C	+1760°C	IEC60584-1
S	-50°C	+1760°C	IEC60584-1
T	-200°C	+400°C	IEC60584-1
U	-200°C	+600°C	DIN 43710
W3	0°C	+2300°C	ASTM E988-90
W5	0°C	+2300°C	ASTM E988-90
Ext. CJC	-40°C	+135°C	IEC60751



Cold junction compensation (CJC)	< ±0.5°C
Sensor error detection	Yes
Sensor error current When detecting	Nom. 4μA
Else	0μA
Short circuit detection	< 3mV

Voltage input:

Measurement range	-800 - +800mV
Min. measurement range (span)	2.5mV
Input resistance	10MΩ

Output:

FOUNDATION™ Fieldbus protocol	FF protocol
Protocol standard.....	FF design specifications
Version	ITK 4.6
Function blocks	2 analogue and 1 PID
Capability	Basic or Master

Observed authority requirements:

EMC 2004/108/EC, Emission and Immunity.....	EN 61326
ATEX 94/9/EC	EN60079-0, EN60079-11, EN60079-15, EN60079-27, EN60079-26, EN61241-0, EN61241-11 EN60079-27 (FISCO)



Accuracy: (The greater of general and basic values)

General values		
Input type	Absolute accuracy	Temperature coefficient
All	≤±0.05% of reading	≤±0.002% of reading / °C

Basic values		
Input type	Basic accuracy	Temperature coefficient
Pt100 and Pt1000	≤ ±0.1°C	≤ ±0.002°C/°C
Ni100	≤ ±0.15°C	≤ ±0.002°C/°C
Cu10	≤ ±1.3°C	≤ ±0.02°C/°C
Lin. R	≤ ±0.05Ω	≤ ±0.002Ω/°C
Volt	≤ ±10μV	≤ ±0.2μV/°C
TC type: E, J, K, L, N, T, U	≤ ±0.5°C	≤ ±0.01°C/°C
TC type: B, R, S, W3, W5	≤ ±1°C	≤ ±0.025°C/°C

EMC immunity influence	<±0.1% of reading
Extended EMC immunity: NAMUR NE21, A criterion, burst	<±1% of reading

MODEL AND SUFFIX CODES

Model	Suffix code	Descriptions
YTA80		Temperature Transmitter (Head Mount Type) FOUNDATION™ Fieldbus protocol
	/KN2	KEMA 05 ATEX 1026X Type n approval II 3 G EEx nA[L] IIC T4...T6
	/KS2	KEMA 05 ATEX 1025 intrinsically safe approval II 1GD EEx ia IIC T4...T6 T65°C...T105°C or II 2(1) GD EEx ib[ja]IIC T4...T6 T65°C...T105°C
	/DRC	Din Rail clip
	/L1	Single point Calibration

Ex data: Signal output/supply, terminal 1 to 2: Max. ambient temperature depends on the Po of the connected barrier.

YTA80/KS2				
Class I, Zone 0, EEx ia IIC, Entity/FISCO				
Unit	Barrier where Po < 0.84W	Barrier where Po < 1.3W	Suitable for FISCO systems	Suitable for FISCO systems
Ui	30VDC	30VDC	17.5VDC	15VDC
Ii	120mADC	300mADC	250mADC	900mADC
Pi	0.84W	1.3W	2.0W	5.32W
Li	1μH	1μH	1μH	1μH
Ci	2.0nF	2.0nF	2.0nF	2.0nF
T1...T4	Tamb.< 85°C	Tamb.< 75°C	Tamb.< 85°C	Tamb.< 85°C
T5	Tamb.< 70°C	Tamb.< 65°C	Tamb.< 60°C	Tamb.< 60°C
T6	Tamb.< 60°C	Tamb.< 45°C	Tamb.< 45°C	Tamb.< 45°C

YTA80/KS2		YTA80/KN2
Class I, Zone 1, EEx ib IIC, Entity/FISCO		Zone 2, EEx nA[L] IIC
Unit	Barrier where Po < 5.32W	FISCO segment coupler
Ui	30VDC	17.5VDC
Ii	250mADC	All
Pi	5.32W	All
Li	1μH	1μH
Ci	2.0nF	2.0nF
T1...T4	Tamb.< 85°C	Tamb.< 85°C
T5	Tamb.< 75°C	Tamb.< 75°C
T6	Tamb.< 60°C	Tamb.< 60°C

Connections:

All connection options are shown in the user manual. Connections with two sensors can be configured for 2 measurements, difference, average or redundancy.

Input:

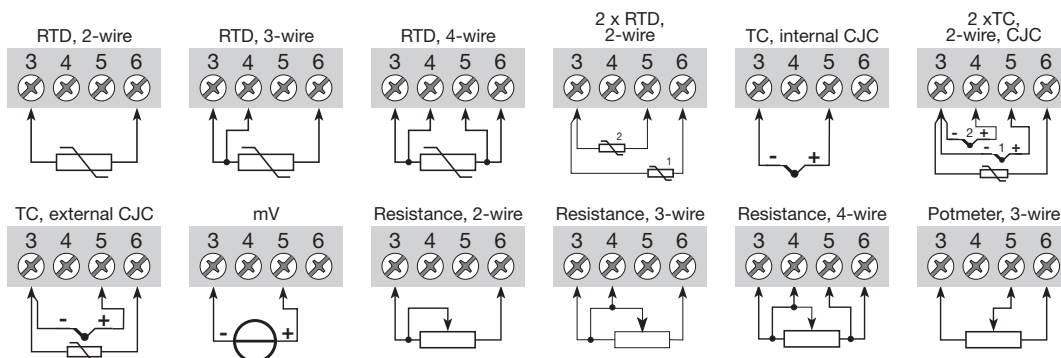

Output:

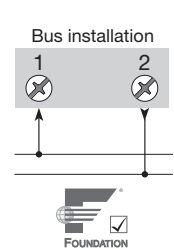

YOKOGAWA ELECTRIC CORPORATION
World Headquarters
 9-32, Nakacho 2-chome, Musashino-shi
 Tokyo 180-8750
 Japan
www.yokogawa.com

YOKOGAWA CORPORATION OF AMERICA
 2 Dart Road
 Newnan GA 30265
 USA
www.yokogawa.com/us

YOKOGAWA EUROPE B.V.
 Euroweg 2
 3825 HD Amersfoort
 The Netherlands
www.yokogawa.com/eu

YOKOGAWA ELECTRIC ASIA Pte. LTD.
 5 Bedok South Road
 Singapore 469270
 Singapore
www.yokogawa.com/sg

YOKOGAWA CHINA CO. LTD.
 3F Tower D Cartelo Crocodile Building
 No.568 West Tianshan Road Changing District
 Shanghai, China
www.yokogawa.com/cn

YOKOGAWA MIDDLE EAST B.S.C.(c)
 P.O. Box 10070, Manama
 Building 577, Road 2516, Busaiten 225
 Muharraq, Bahrain
www.yokogawa.com/bh

Yokogawa has an extensive sales and distribution network. Please refer to the European website (www.yokogawa.com/eu) to contact your nearest representative.



YOKOGAWA ◆

GS 01C50C04-01E-E

Subject to change without notice
 Copyright©

Printed in The Netherlands, 3-1104 (A) I