

PST Scheduler Engineering Guide with Fisher positioner

Copyright and Trademark Notices

■ Trademark Acknowledgments

All Right Reserved, Copyright 2012 © Yokogawa Electric Corporation

For Chapter 8 courtesy of Fisher Controls, Copyright 2012 © Fisher Controls.

■ Trademark Acknowledgments

- PRM is a registered trademark of Yokogawa Electric Corporation in the United States and Japan.
- ProSafe and Vnet/IP are registered trademarks of YOKOGAWA.
- Microsoft, Windows are either registered trademarks or trademarks of Microsoft Corporation in the United States and/or other countries.
- Ethernet is a registered trademark of XEROX Corporation.
- HART is a registered trademark of the HART Communication Foundation.
- All other company and product names mentioned in this manual are trademarks or registered trademarks of their respective companies.
- We do not use TM or ® mark to indicate those trademarks or registered trademarks in this manual.

Contents

1	Introduction	4
2	PST Device	5
3	System configuration.....	6
4	PST Scheduler workflow.....	7
5	Detailed PST Scheduler setup.....	8
5.1	Connection between device and controller (SCS)	8
5.2	Registration to PRM of device.....	8
5.3	Exporting the device list.....	10
5.4	Configuring the PST Scheduler Client connection.....	11
5.5	Starting the PST Scheduler Client.....	11
5.6	Importing device information.....	12
5.7	Managing PST groups	14
5.8	Arranging devices into groups	14
5.9	Scheduling a PST.....	15
5.10	Check a PST function	16
5.11	Confirm the status of the PST function in PRM.....	17
6	The PST setting.....	18
7	The example of PST schedule.....	19
7.1	Maximum duration.....	19
7.2	PST Mode	20
7.3	PST Execution Mode.....	21
8	The connection for every device.....	22
8.1	Fisher DVC6000 SIS	22
8.1.1	Feature.....	22
8.1.2	System configuration	23
8.1.3	Equipments list.....	23
8.1.4	DTM	24
8.1.5	Wiring	25
8.1.6	Application.....	26
8.1.7	PST related parameter	26
8.1.8	Valve operation in PST	27

1 Introduction

This document is an engineering guide of PST Scheduler (the R3.04.00 or later edition of PRM) with Fisher positioner. The purpose of this document is for an engineer to understand how to use PST Scheduler and to build a demo system. Therefore, it is the minimum composition needed in order to operate PST. In a real job, the system configuration and engineering according to plant operation are required.

Chapter 2 – 7: Engineering guide of PST Scheduler.

Chapter 8: Settings for Fisher positioner.

2 PST Device

The following list shows the positioners and DTMs which have passed the integration test with PST Scheduler. The newest information can be referred to by the following website.

< <http://www.yokogawa.com/fbs/Interoperability/fbs-pst-en.htm> >

Table 2-1 Integration test with PST Scheduler

Vendor	Device Model	Protocol	Device Rev.	Manufacturer ID	Device Type	Remark
Dresser	SVI II ESD	HART	1	000065	00CB	R3.04 or later
Fisher	DVC6000 SIS	HART	2	000013	0003	R3.04 or later
Flowserve	Logix3200MD	HART	2	000030	0005	R3.04 or later
Metso Automation	VG800	HART	6	000057	00EB	R3.04 or later Metso valve needs a RCI (Remoting Communication Interface) card
Metso Automation	VG9000H	HART	1	000057	00D9	R3.05 or later Metso valve needs a RCI (Remoting Communication Interface) card
Samson AG	373x-3	HART	6	000042	00EF	R3.04 or later

3 System configuration

The target engineering of this book is building the system of Figure 3-1, in order to perform the following operation.

- The device which is the target of PST is registered into PRM.
- PST is started from PST Scheduler.
- An ESD function is started from the switch connected to SCS (ProSafe-RS).

The ESD valve (valve positioner) which is the target of PST Scheduler differs in connection with SCS for every model, and differs also in ESD operation. There is what performs ESD by turning on a contact output, a thing which performs ESD by making below fixed an analog output (4-20 mA), etc. in a valve positioner, and the application corresponding to each is needed.

In this book, execution of ESD is started by turning ON (closed) a contact input switch. No interlock for a start is constructed (take into consideration in a real job).

Refer to Chapter 8 for the connection method for every ESD valve.

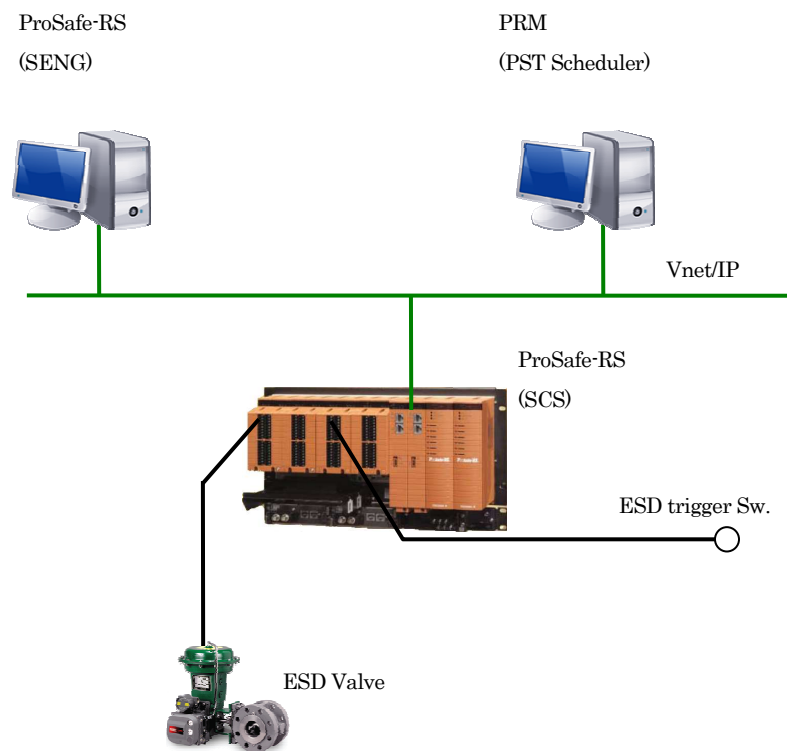

Figure 3-1 System configuration

4 PST Scheduler workflow

The work flow about a setup of PST Scheduler is as follows.

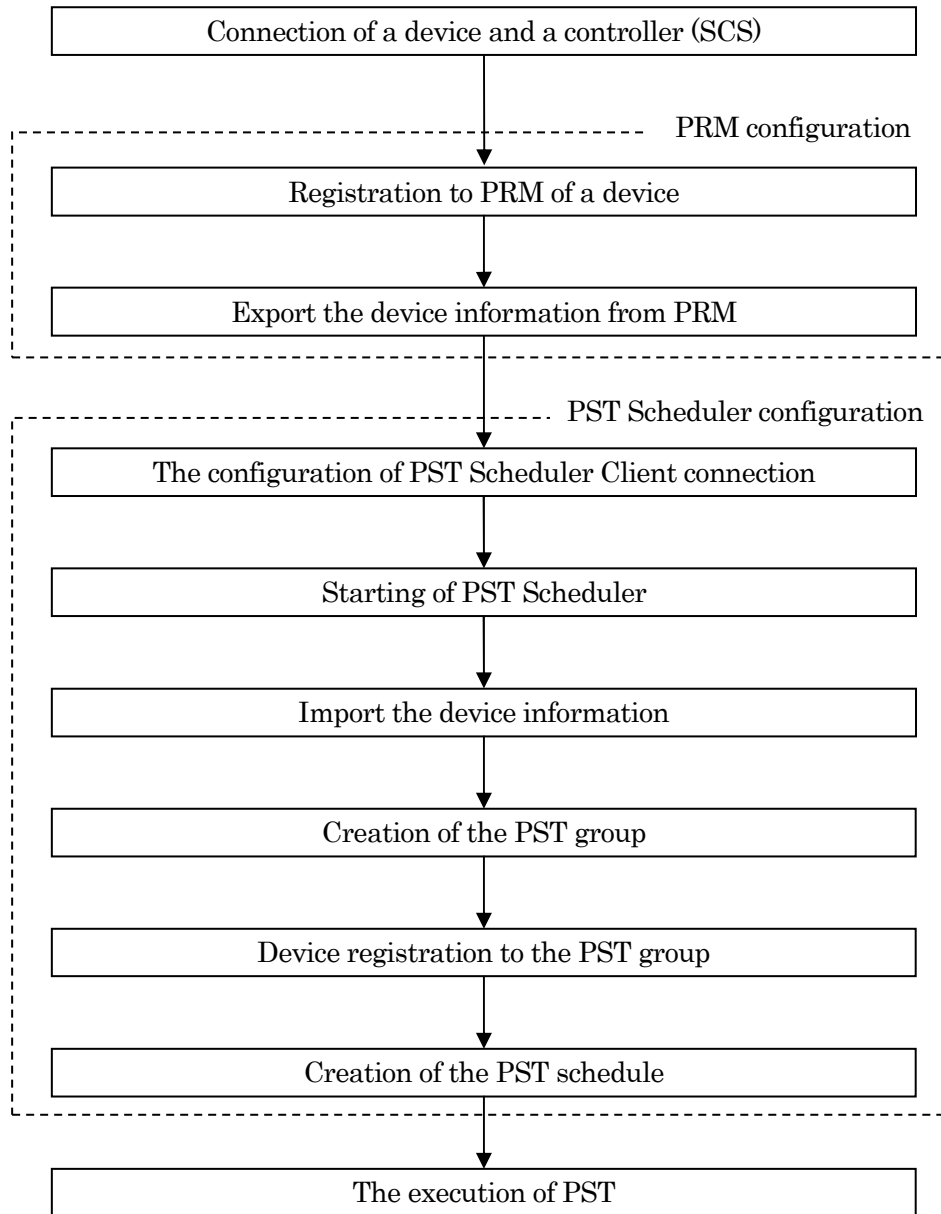

Figure 4-1 Workflow

5 Detailed PST Scheduler setup

The details of each work in a setup of PST Scheduler are described below.

5.1 Connection between device and controller (SCS)

The device (valve positioner) which performs PST is connected to a controller (SCS). Refer to Chapter 8 for the connection method.

5.2 Registration to PRM of device

The device needs to be registered into PRM in order to operate a device by PST Scheduler.

1) Set up Device Path

About IO module which connected the device, Device Path is set up with the setup tool of PRM.

2) DD file copy

DD file of a device is copied to the folder of PRM. DD file comes to hand from a vendor. The copy place of a DD file is as follows.

(PRM installation drive)\PRM\DD\HART\000042\00EF

3) DTM installation

DTM of an object device is installed. DTM comes to hand from a vendor.

4) Plug & Play Execution

Plug & Play is performed by PRM and a device is registered.

-Trouble Shoot

A device cannot be recognized

->The connection mistake of a device

->The HART module of a valve is not operating since the output to a valve is 0% (less than 4mA).

->0.1% or more (100% recommendation) of the output to a valve is used.

->The address is set as the device.

->The address of a device is changed into 0.

->The range of the polling address of a Device Path setup is extended.

5) Associating the DTM to the device

It is necessary to associate the DTM to the device.

The item “DTM Works...” in the right-click menu at the device is not gray out if the DTM is already associated to the device.

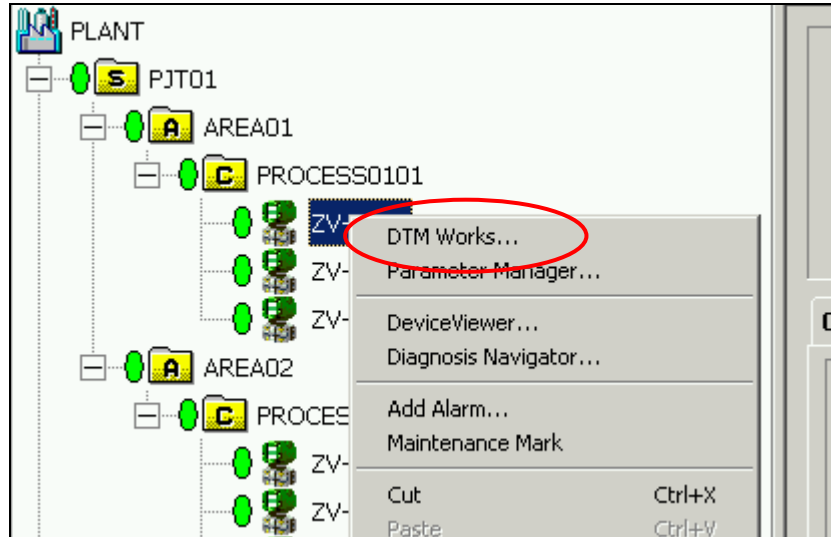

Figure 5-1 Device associated to the DTM

To associate the DTM with device, you must perform the following operations if the DTM is not associated to the device:

- 1) On the left pane of the PRM Setup Tool, expand PRM Client and select [DTM Setup].
- 2) On the right pane, click [Start DTM Setup].
A dialog box appears, asking if you want to update the DTM catalog.
- 3) Click [Yes].
The catalog update process starts. After it completes, the DTM Setup window appears, displaying a list of DTMs installed on the local computer and their device class association.
- 4) Find the DTM that you have just installed by looking at the Name column.
- 5) Associate the DTM to a device class by selecting the appropriate values from the drop-down lists available in the cells under the following columns:
 - Vendor
 - Model
 - Revision
- 6) Click [OK].

You can now use the DTM to configure a device of the corresponding class in PRM Client.

DTM Name	DTM Revision	Comm. Type	DTM Vendor	Vendor	Model	Device Revision
Fisher Controls DVC6000 v02.01	1.4.138.7	HART	Fisher Controls	Fisher Controls	DVC6000	2
Lgx3200MD	5	HART	Flowserve	Flowserve Corporation	0x0005	2
SAMSON 373X-3 (Rev5)	1.44	HART	SAMSON AG			
SAMSON 373X-3 (Rev6)	1.51	HART	SAMSON AG	SAMSON AG	3730	6
SVI II ESD HART	203-3.1	HART	Dresser Masonella	Dresser Valve Division	SVI2ESD	1
VG800	2.0	HART	Metso Automation	Metso Automation	ValvGuard	6
VG800	1.0	HART	Metso Automation			

Figure 5-2 Associating the DTM to the device

5.3 Exporting the device list

The device registration to the PST Scheduler is performed through the device list exported from PRM. Follow these steps to export the device list:

- 1) Right-click anywhere in the device list, and select [Export Device List].
Alternatively, from the menu bar, select [File] > [Export] > [Device List].
- 2) In the file selection dialog box, navigate to the location where you want to export the file.
- 3) Type a file name for the device list that you are exporting.
The default file name is "PRMDeviceList.csv".
- 4) Click [Save].
The device list is exported.

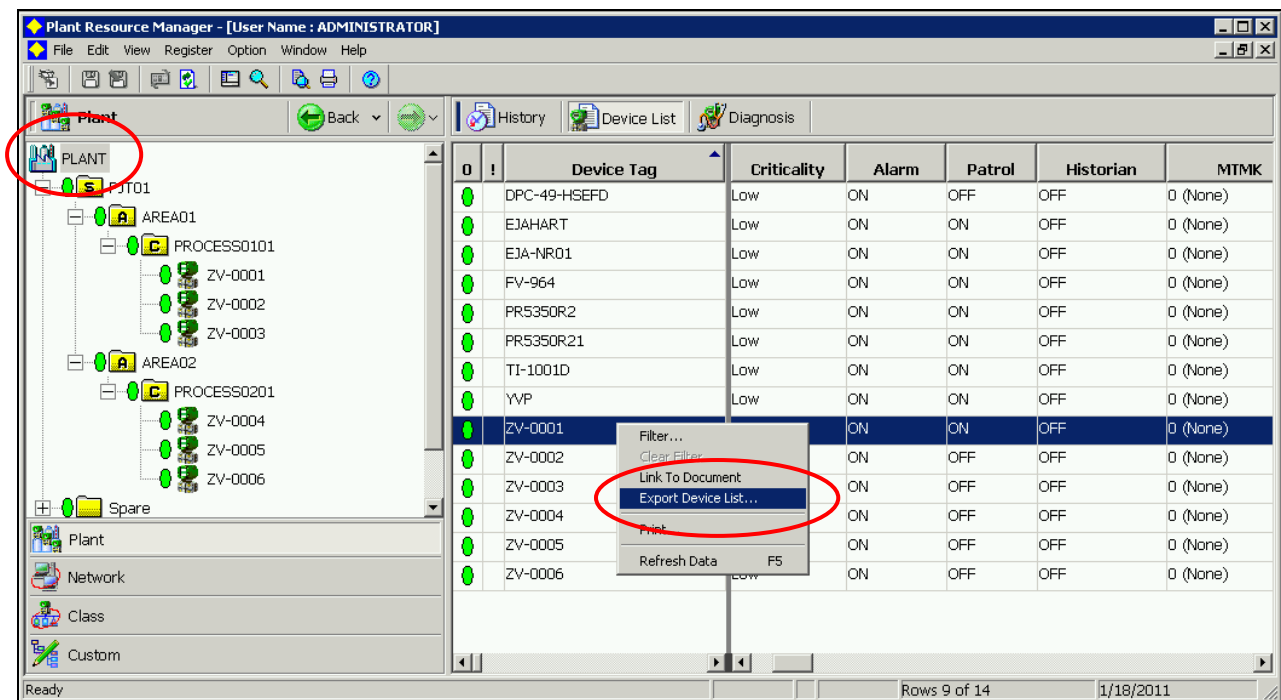

Figure 5-3 Exporting the device list

5.4 Configuring the PST Scheduler Client connection

Follow these steps to configure the PST Scheduler Client connection:

- 1) From your desktop, select [Start] > [All Programs] > [YOKOGAWA PRM] > [Tool] > [PST Scheduler Setup Tool].
The PST Scheduler Setup Tool window appears.
- 2) On the left pane of the PST Scheduler Setup Tool, expand PST Scheduler and select [Connection].
The PST Scheduler Server box appears on the right pane.
- 3) In the PST Scheduler Server box, type the computer name or IP address of the computer installed with the PST Scheduler Server.
- 4) Click [Apply].

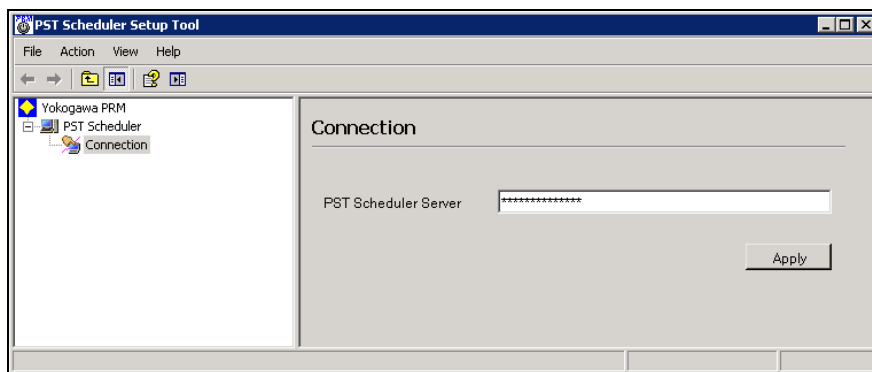

Figure 5-4 PST Scheduler Setup Tool

5.5 Starting the PST Scheduler Client

Follow these steps to start the PST Scheduler Client:

- 1) From your desktop, select [Start] > [All Programs] > [YOKOGAWA PRM] > [PST Scheduler].
The PST Scheduler - Login dialog box appears.
- 2) Login as “Administrator” account.
The passwords for these accounts are the same as the user names.



Figure 5-5 PST Scheduler - Login dialog box

5.6 Importing device information

The device information is imported the device list exported from the PRM Client. Follow these steps to import a CSV file that contains the device list from the PRM system:

- 1) Open the Group Management window.
Click [Configuration] menu, and then click [Device List] icon.

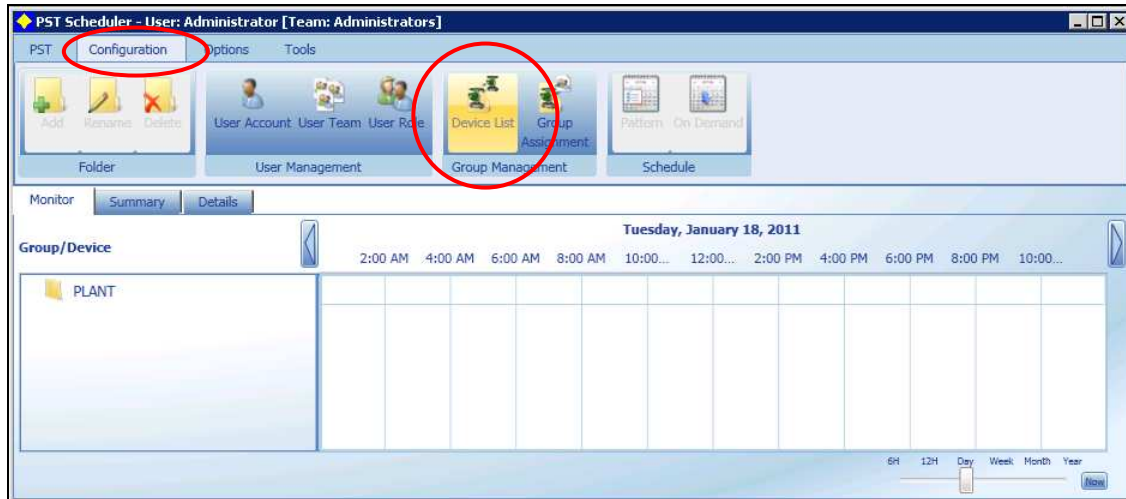

Figure 5-6 Group Management window

- 2) On the Ribbon, click [Import].
The Open dialog box appears.
- 3) Select the CSV file and click [Open] to import the CSV file.



Figure 5-7 Group Management window

- 4) In the dialog box, select the devices to import by performing these steps:
 - (1) In the PRM Server box, type the name or IP address of the computer installed with the PRM

Server.

- (2) In the Field Communication Server box, type the name or IP address of the computer installed with the Field Communications Server.
- (3) From the Device Tag list, select the check boxes of the devices that you want to import.

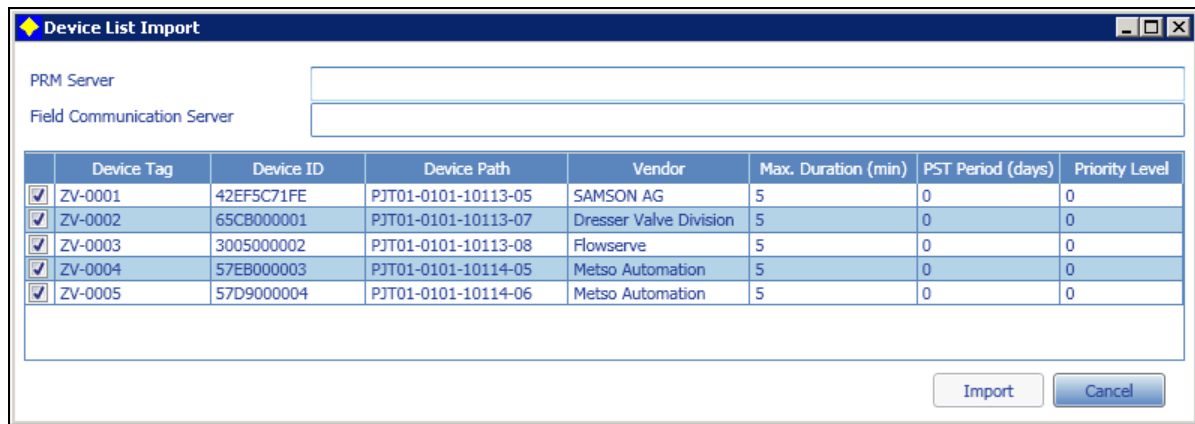

Figure 5-8 Select the devices to import

- 5) Click [Import].

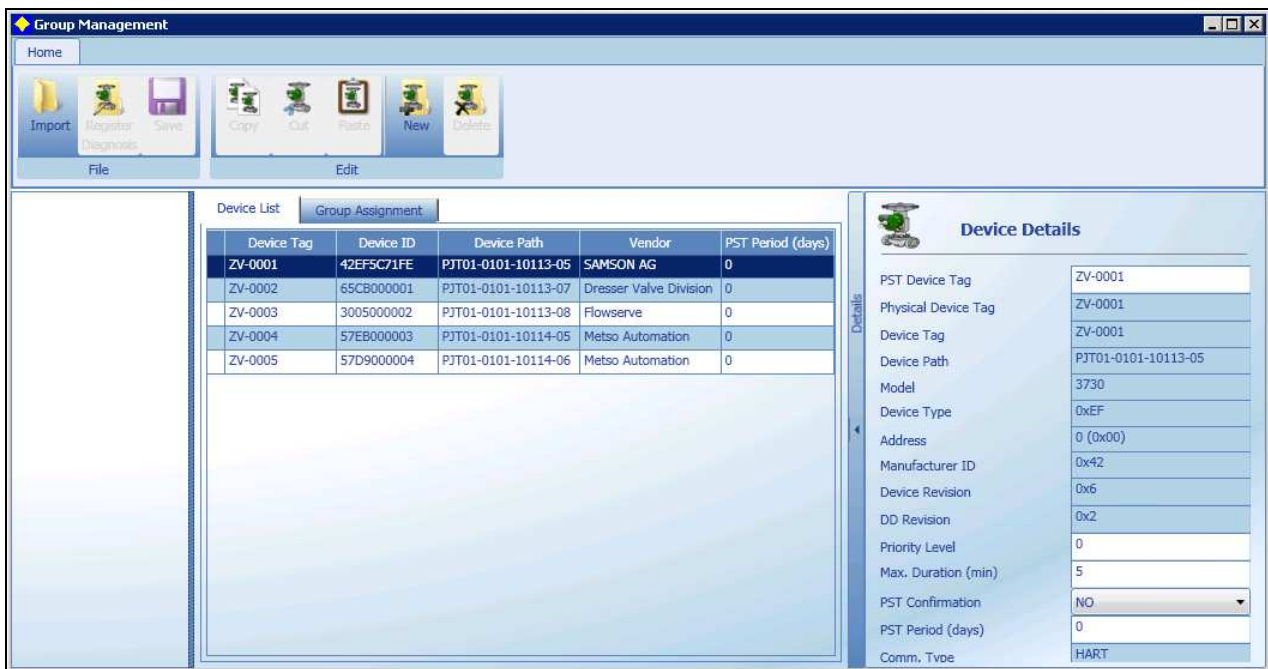

Figure 5-9 Imported devices

5.7 Managing PST groups

It is necessary to create PST group because the PST is scheduled by the group.

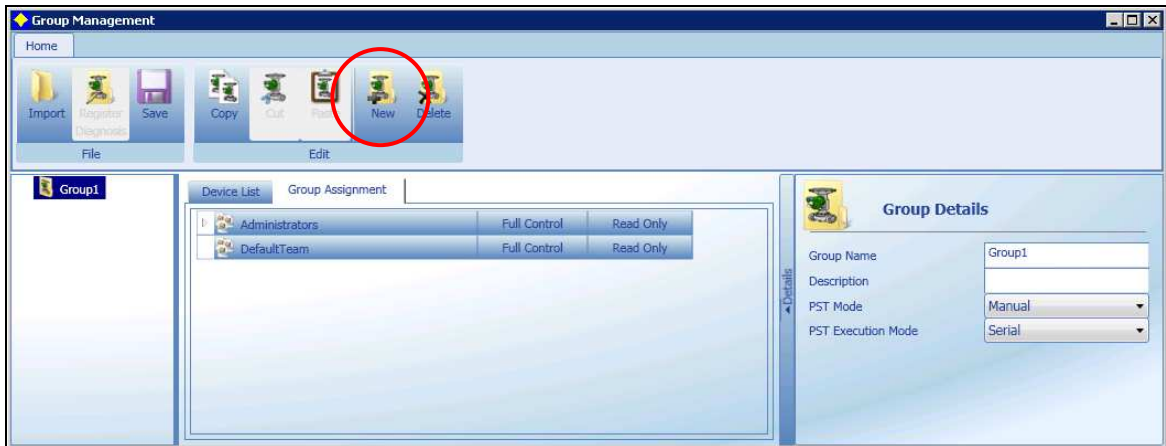

Figure 5-10 Create PST group

5.8 Arranging devices into groups

Drag and drop the selected device(s) into the destination group.

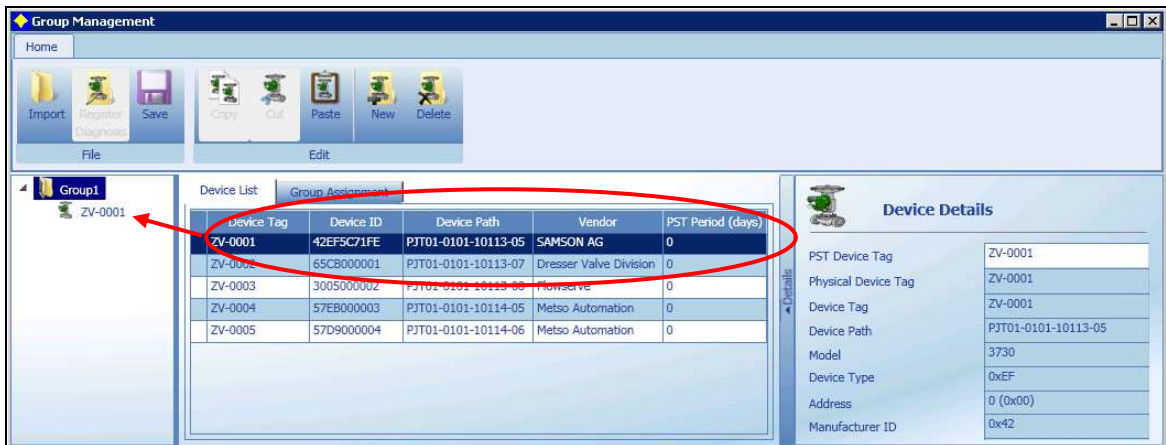

Figure 5-11 Arranging devices into groups

5.9 Scheduling a PST

Configure the PST schedules of a group. Follow these steps to open the PST Group Scheduler dialog box:

- 1) In the Schedule group of the Configuration tab, click, [Pattern] icon
The PST Group Scheduler dialog box appears.

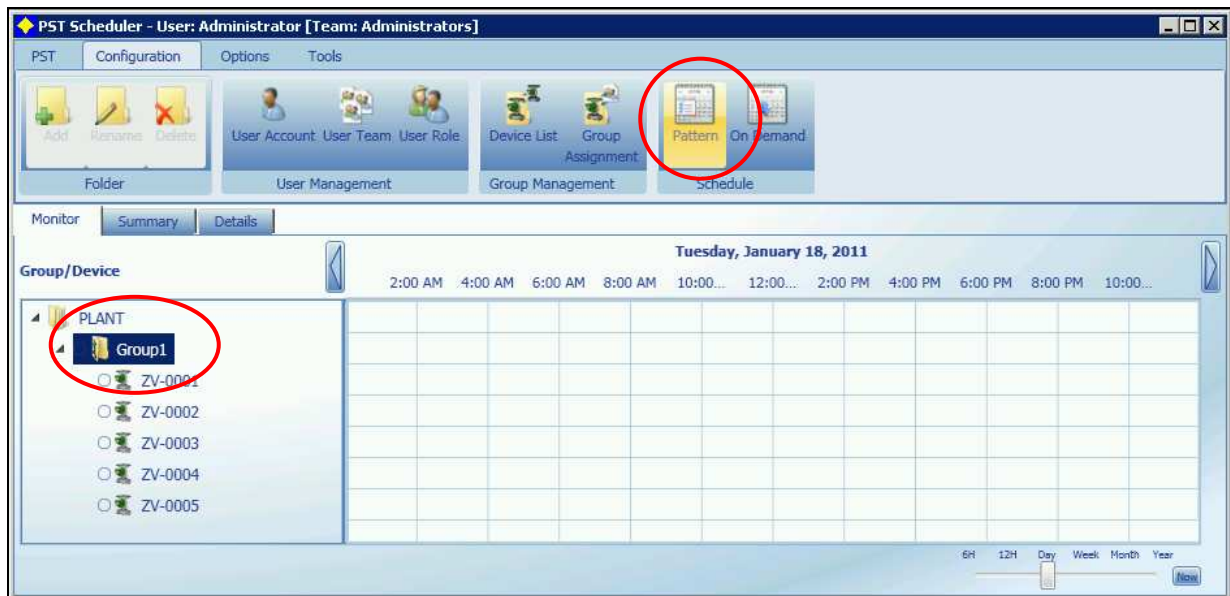

Figure 5-12 PST Group Scheduler dialog box

- 2) Scheduling a pattern PST

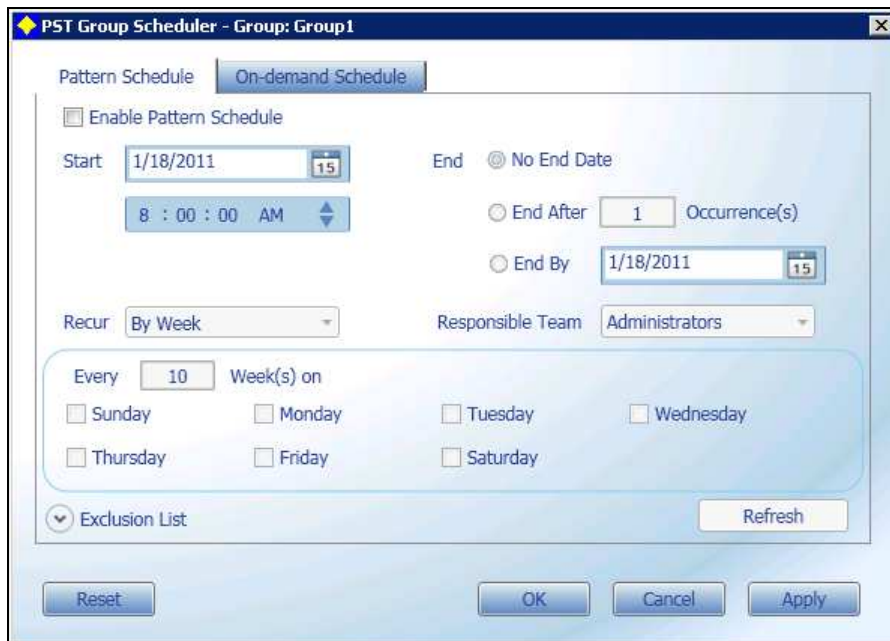

Figure 5-13 Scheduling a pattern PST

- 3) Click [OK].
The PST schedule for the group is displayed in the Monitor tab of the PST Scheduler Client window.

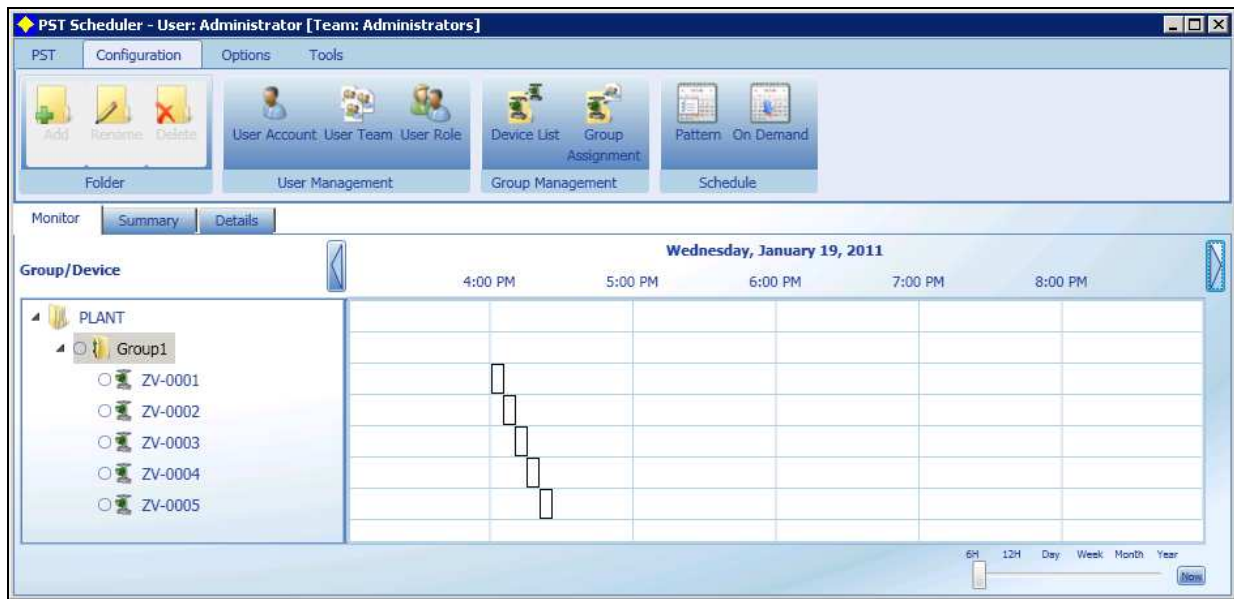

Figure 5-14 Monitor tab of the PST Scheduler Client window

5.10 Check a PST function

Check a PST function. There are the following two methods in execution of a PST function.

- Waiting for the time scheduled the PST function.
- Execution by manual.
Click [Start] in the PST tab of the Ribbon.

5.11 Confirm the status of the PST function in PRM

The status of the PST function can be confirmed as the Maintenance Alarm in PRM.

The screenshot displays the Plant Resource Manager (PRM) interface. The left sidebar shows a tree view of the plant structure, including PJT01, AREA01, PROCESS0101, and ZV-0001. The main window shows a 'History' tab with a table of maintenance events. The table has columns for Occurrence Time, Device Tag, Object Criticality, Message Priority, and a description. The details pane below the table shows the following information:

Occurrence Time	Device Tag	Object Criticality	Message Priority	
1/19/2011 12:01:45	ZV-0001	Low	Low	PST Success
1/19/2011 11:59:33	ZV-0001	Low	Low	Device is normal.
1/19/2011 11:56:55	ZV-0001	Low	High +	PST Fail
1/19/2011 11:48:41	ZV-0001	Low	Low	PST Success

Details:

<Title(Message Number)>
PST Success(0)

<Model Name(Object Name)>
3730(ZV-0001)

<Location>
DevicePath=PJT01-0101-10113-05

<Problem>
PST Success

<Action>
Action is not required.
For the confirmation, please click to launch [PST Scheduler Client](#).
PST Scheduler Client shows the current status and past history to help your further detail analysis.

<Diag ID>
8

<Diag Name>
PST Scheduler

Figure 5-15 Maintenance Alarm

6 The PST setting

The PST Scheduler only transmits a PST execution command to the device. So it is necessary to set up with the parameters of the device for the PST function.

Since these setting are different for every device, refer Chapter 8 for them.

7 The example of PST schedule

The sample setting for the demonstration is given.

7.1 Maximum duration

The “Max. Duration” is the maximum duration is to conduct a PST. Follow these steps to set that:

- 1) Open the Group Management window.
- 2) Select the device, and the input “Max. Duration”.

The maximum of PST execution time is set up here. When the execution time of the PST exceeds the set period of “Max. Duration”, it becomes the end of an error by timeout. The default of “Max. Duration” is 5 (min).

It is necessary to set up this “Max. Duration” according to the device if the execution time of PST is set up for a long time by the configuration of the device,

The screenshot shows the 'Group Management' window with a 'Device List' table and a 'Device Details' panel. The 'Max. Duration (min)' field in the 'Device Details' panel is highlighted with a red circle.

Device Tag	Device ID	Device Path	Vendor	PST Period (days)
ZV-0001	42EF5C71FE	PJT01-0101-10113-05	SAMSON AG	0
ZV-0002	65CB000001	PJT01-0101-10113-07	Dresser Valve Di	0
ZV-0003	3005000002	PJT01-0101-10113-08	Flowserve	0
ZV-0004	57EB000003	PJT01-0101-10114-05	Metso Automatic	0
ZV-0005	57D9000004	PJT01-0101-10114-06	Metso Automatic	0

Device Details

PST Device Tag	ZV-0001
Physical Device Tag	ZV-0001
Device Tag	ZV-0001
Device Path	PJT01-0101-10113-05
Model	3730
Device Type	0xEF
Address	0 (0x00)
Manufacturer ID	0x42
Device Revision	0x6
DD Revision	0x2
Priority Level	0
Max. Duration (min)	5
PST Confirmation	NO
PST Period (days)	0
Comm. Type	HART
Vendor	SAMSON AG
Related Tag	
Maintenance Status	NO

Figure 7-1 Max. Duration

7.2 PST Mode

There are three kinds of PST Mode, Manual (manual operation), Semi-Auto (semiautomatic), and Auto (automatic). The following operation is performed, when it becomes the scheduled PST execution time.

This setting is chosen at the [PST Mode] in the Group Management window.

Manual:

The PST Scheduler displays a reminder to the user, informing that it is time to perform a scheduled PST. However, the user needs to perform PST for the devices manually.

Semi-Auto:

The PST Scheduler asks for confirmation from the user before it performs a scheduled PST for the group.

Auto:

The PST Scheduler performs a scheduled PST for the group without asking confirmation from the user.

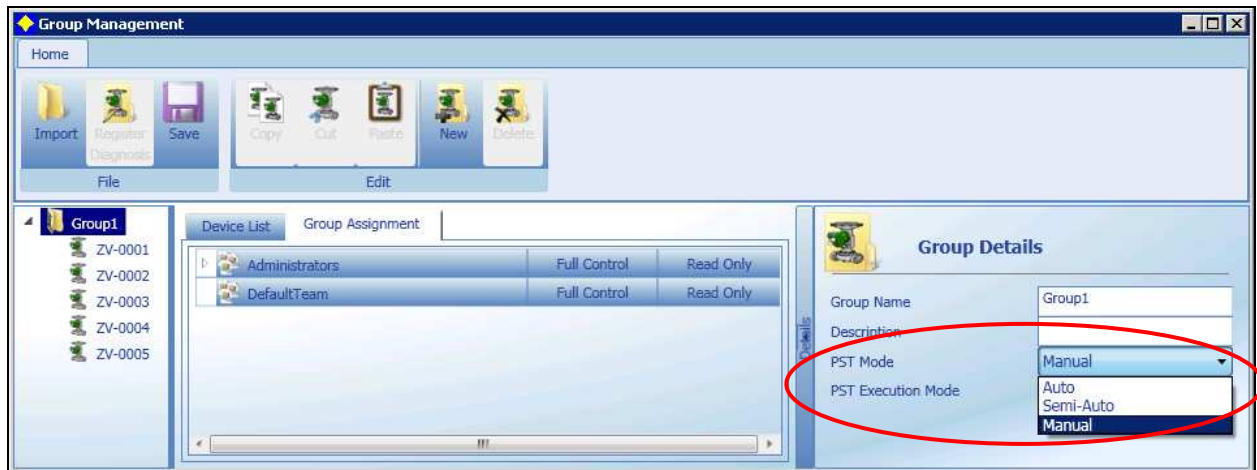

Figure 7-2 PST Mode

7.3 PST Execution Mode

There are two kinds of schedules of PST, Serial and Parallel.

This setting is chosen at the [PST Execution Mode] in the Group Management window.

Serial:

The PST Scheduler performs PST on devices in the group one by one, starting from the top of the list.

Parallel:

The PST Scheduler performs PST on all devices in the group at the same time.

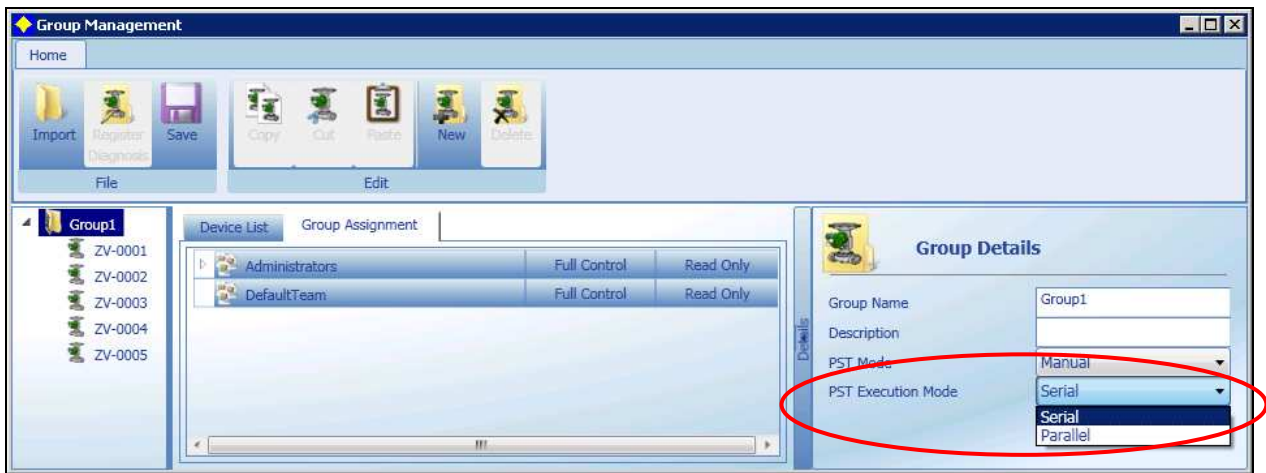

Figure 7-3 PST Execution Mode

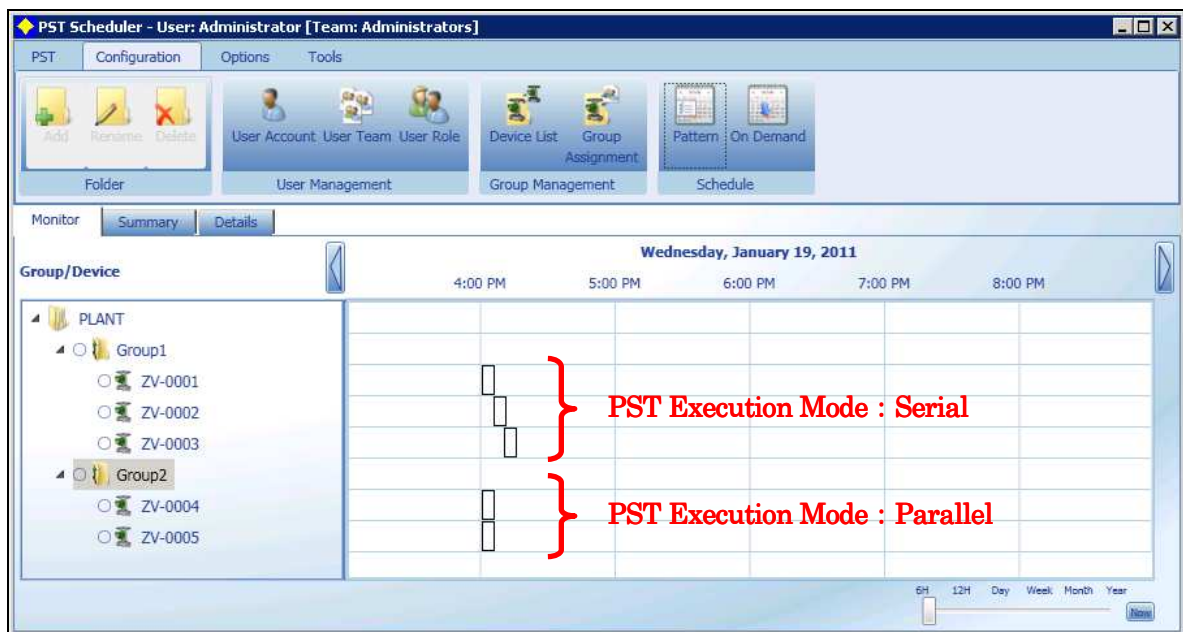

Figure 7-4 Difference in the PST Execution Mode

8 The connection for every device

8.1 Fisher DVC6000 SIS

8.1.1 Feature

There are the following features in this device.

ESD:

The ESD function will operate, if an output is less than the value set up with the Tvl/Press Cutoffs parameter. The default value of the Tvl/Press Cutoffs parameter is 50%.

SIL:

This device is certified as suitable for use in a SIL3 application. (When the control signal is 0 - 20 mA, 0 – 24 V or 4 – 20 mA)

FST:

Since this device can set up the working range of PST up to 30%, it cannot perform FST (Full Stroke Test) using PST Scheduler.

Connection between ProSafe-RS and PRM:

HART communication is made by AO module.

ValveLink™ DTM:

ValveLink software can be used to set up and test the DVC6000 SIS in safety instrumented system applications. ValveLink software for DVC6000 SIS digital valve controllers provides:

- “Setup Wizard” feature to configure the DVC6000 SIS digital valve controller for use in a Safety Instrumented System with pictorial pneumatic hookup representation to help ensure tubing is correctly connected.
- Simultaneous overlay of up to ten Valve Signature and Partial Stroke diagnostic tests. This allows graphical comparison of valve variation from a history of diagnostic tests.
- “Signature Analyzer” feature to automate the interpretation of Valve Signature and Partial Stroke diagnostic data. The Signature Analyzer uses a set of user configurable limits to help determine possible issues with the valve assembly, such as a broken shaft or stem.

8.1.2 System configuration

The example of system configuration is as follows.

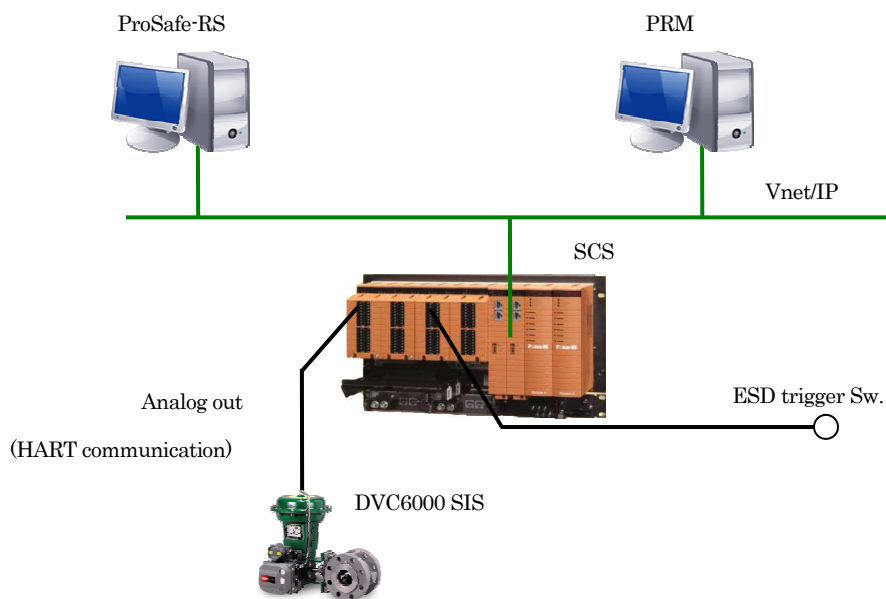

Figure 8-1 Example of system configuration

8.1.3 Equipments list

The equipments for example of systems configuration (Figure 8-1) are shown in the following table.

Table 8-1 Equipment list

Item	Name	Model/ Software revision	Manufacturer	Remark
SCS	Duplexed Safety Control Unit	SSC50D	Yokogawa	Including redundant PSU (100-120VAC) & CPU module
AO (installed in SCS)	16ch Analog Output Module (HART communication)	SAI533-H33	Yokogawa	With Hart communication
DVC6000 SIS	Partial Stroke Test device	DVC6000 SIS	Fisher	
(SENG)	ProSafe-RS software	R1.02.00	Yokogawa	
(PRM)	PRM software	R3.04.00	Yokogawa	Including DTM works
(PRM)	DTM software	DVC6000 SIS ValveLink DTM 11.1	Fisher	

8.1.4 DTM

DTM used for the combination test with PST Scheduler is shown in the following table.

Table 8-DVC6000 SIS DTM

Vendor	Device Model	Protocol	DTM Version	Manufacturer ID	Device Type	Device Rev.
Fisher	DVC6000 SIS	HART	ValveLink DTM 11.1	0x13	0x03	2

It is necessary to obtain this DTM from the Fisher.

In order to register this DTM into PRM, it sets up as follows by DTM Browser.

DTM Name	DTM Revision	DTM Vendor	Vendor	Model	Device Revi...
DVC6000	5	Fisher Controls International LLC	Fisher Controls	DVC6000	1
DVC6200/DVC6000	3	Fisher Controls International LLC	Fisher Controls	DVC6000	2
DYF V1.1	1.4.160.0	YOKOGAWA	YOKOGAWA	DYF	1
DYF V2.1	1.4.160.0	YOKOGAWA	YOKOGAWA	DYF	2
DYF V3.1	1.4.160.1	YOKOGAWA	YOKOGAWA	DYF	3
F.M.V1.2	1.4.155.1.4	YOKOGAWA	YOKOGAWA	F.M.	1

8.1.5 Wiring

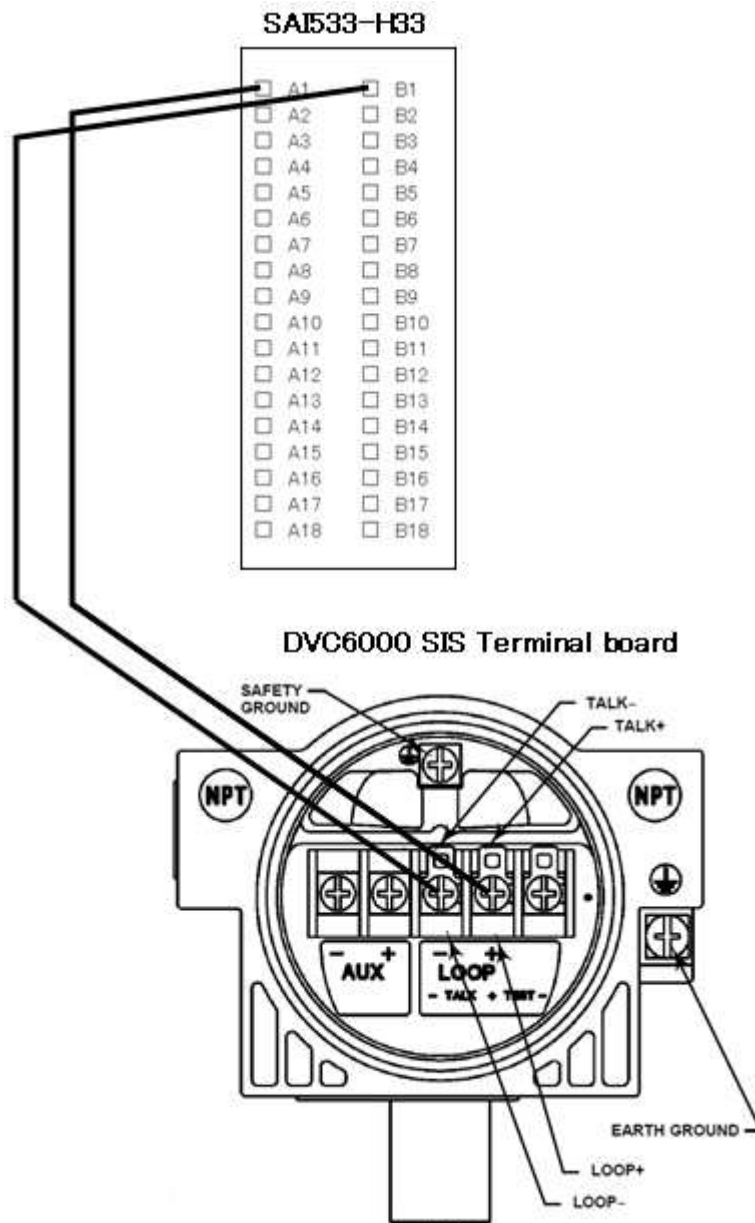

Figure 8-2 Wiring

8.1.6 Application

The example of an application with Yokogawa ProSafe-RS is as follows.
 The ESD function will operate, if the DI (ex. DI010301) is true.

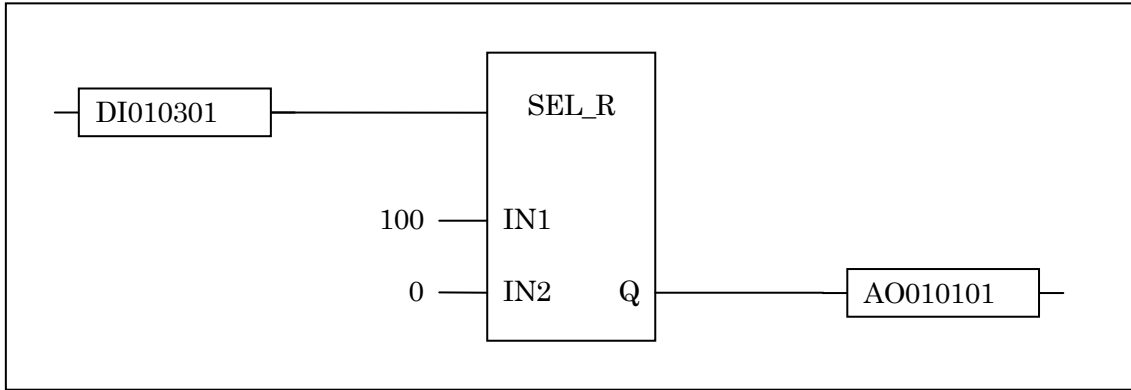

Figure 8-3 Application

8.1.7 PST related parameter

Please refer to the DVC6000 SIS Instruction Manual Supplement (Part number D103285X012) for instrument setup using ValveLink™ software which can be found online at:
http://www.documentation.emersonprocess.com/groups/public/documents/instruction_manuals/d103285x012.pdf.

Recommended values are as follows.

Table 8-2 PST related parameter

Parameter	Recommended value	
Max Travel Movement	10%	Valve travel of PST (%) Range: 0.0 – 30.0%
Stroke Speed	1%/sec	Ramp rate of PST (%/sec) 1%/sec, 0.5%/sec, 0.25%/sec, 0.12%/sec, 0.06%/sec
Pause Time	10 sec	Stand-by time in the PST Target (sec) 5sec, 10sec, 15sec, 20sec, 30 sec

8.1.8 Valve operation in PST

Valve operation in PST is as follows.

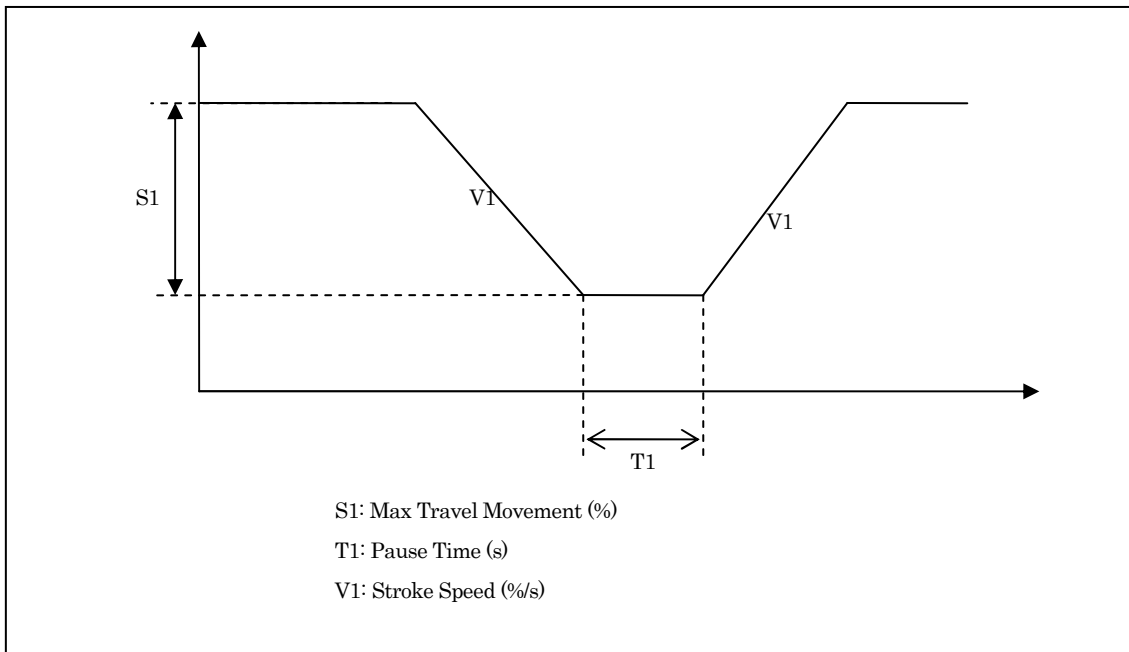

Figure 8-4 Valve operation in PST