

PST Scheduler Engineering Guide with Flowserve positioner

Copyright and Trademark Notices

■ Trademark Acknowledgments

All Right Reserved, Copyright 2012 © Yokogawa Electric Corporation
For Chapter 8 courtesy of Flowserve, Copyright 2012 © Flowserve.

■ Trademark Acknowledgments

- PRM is a registered trademark of Yokogawa Electric Corporation in the United States and Japan.
- ProSafe and Vnet/IP are registered trademarks of YOKOGAWA.
- Microsoft, Windows are either registered trademarks or trademarks of Microsoft Corporation in the United States and/or other countries.
- Ethernet is a registered trademark of XEROX Corporation.
- HART is a registered trademark of the HART Communication Foundation.
- All other company and product names mentioned in this manual are trademarks or registered trademarks of their respective companies.
- We do not use TM or ® mark to indicate those trademarks or registered trademarks in this manual.

Contents

1	Introduction	4
2	PST Device	5
3	System configuration.....	6
4	PST Scheduler workflow.....	7
5	Detailed PST Scheduler setup.....	8
5.1	Connection between device and controller (SCS)	8
5.2	Registration to PRM of device.....	8
5.3	Exporting the device list.....	10
5.4	Configuring the PST Scheduler Client connection.....	11
5.5	Starting the PST Scheduler Client.....	11
5.6	Importing device information.....	12
5.7	Managing PST groups	14
5.8	Arranging devices into groups	14
5.9	Scheduling a PST.....	15
5.10	Check a PST function	16
5.11	Confirm the status of the PST function in PRM.....	17
6	The PST setting.....	18
7	The example of PST schedule.....	19
7.1	Maximum duration.....	19
7.2	PST Mode	20
7.3	PST Execution Mode.....	21
8	The connection for every device.....	22
8.1	Flowserve Logix3200MD.....	22
8.1.1	Feature.....	22
8.1.2	System configuration	23
8.1.3	Equipments list.....	24
8.1.4	DTM	24
8.1.5	Wiring	25
8.1.6	Application.....	26
8.1.7	PST related parameter	26
8.1.8	Valve operation in PST	28

1 Introduction

This document is an engineering guide of PST Scheduler (the R3.04.00 or later edition of PRM) with Flowserve positioner. The purpose of this document is for an engineer to understand how to use PST Scheduler and to build a demo system. Therefore, it is the minimum composition needed in order to operate PST. In a real job, the system configuration and engineering according to plant operation are required.

Chapter 2 – 7: Engineering guide of PST Scheduler.

Chapter 8: Settings for Flowserve positioner.

2 PST Device

The following list shows the positioners and DTMs which have passed the integration test with PST Scheduler. The newest information can be referred to by the following website.

< <http://www.yokogawa.com/fbs/Interoperability/fbs-pst-en.htm> >

Table 2-1 Integration test with PST Scheduler

Vendor	Device Model	Protocol	Device Rev.	Manufacturer ID	Device Type	Remark
Dresser	SVI II ESD	HART	1	000065	00CB	R3.04 or later
Flowserve	Logix3200MD	HART	2	000030	0005	R3.04 or later
Metso Automation	VG800	HART	6	000057	00EB	R3.04 or later Metso valve needs a RCI (Remoting Communication Interface) card
Metso Automation	VG9000H	HART	1	000057	00D9	R3.05 or later Metso valve needs a RCI (Remoting Communication Interface) card
Samson AG	373x-3	HART	6	000042	00EF	R3.04 or later

3 System configuration

The target engineering of this book is building the system of Figure 3-1 **System configuration**, in order to perform the following operation.

- The device which is the target of PST is registered into PRM.
- PST is started from PST Scheduler.
- An ESD function is started from the switch connected to SCS (ProSafe-RS).

The ESD valve (valve positioner) which is the target of PST Scheduler differs in connection with SCS for every model, and differs also in ESD operation. There is what performs ESD by turning on a contact output, a thing which performs ESD by making below fixed an analog output (4-20 mA), etc. in a valve positioner, and the application corresponding to each is needed.

In this book, execution of ESD is started by turning ON (closed) a contact input switch. No interlock for a start is constructed (take into consideration in a real job).

Refer to Chapter 8 for the connection method for every ESD valve.

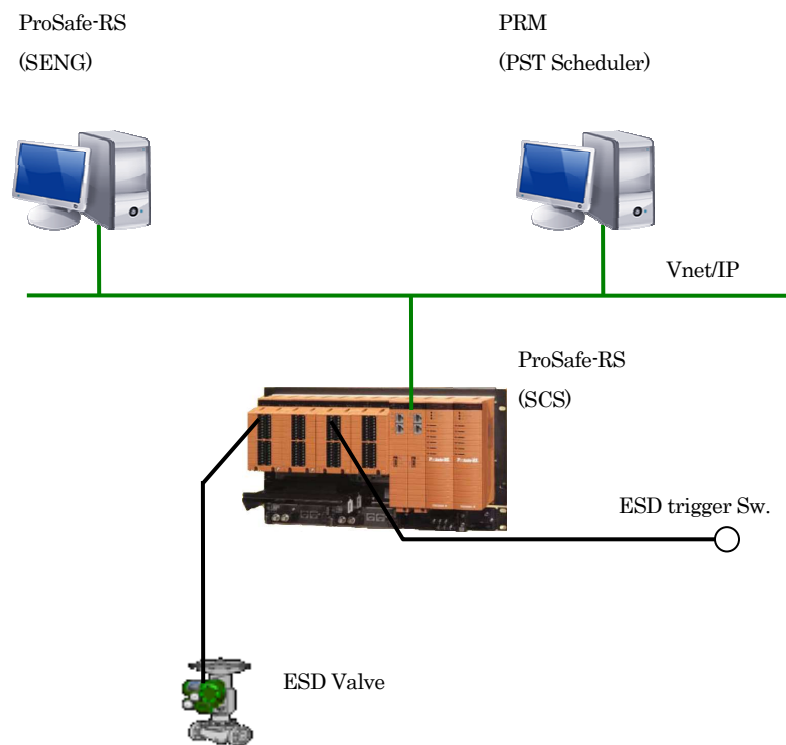

Figure 3-1 System configuration

4 PST Scheduler workflow

The work flow about a setup of PST Scheduler is as follows.

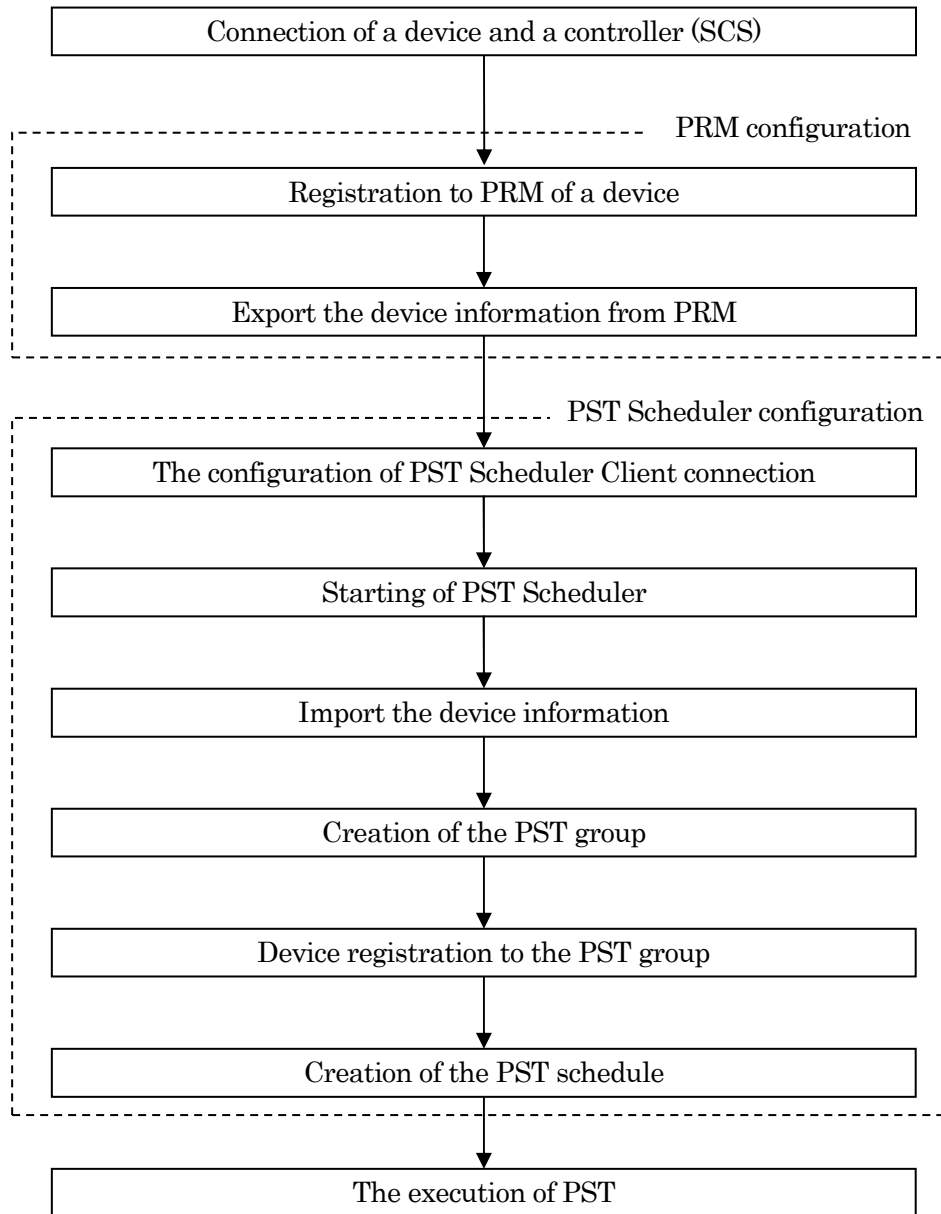

Figure 4-1 Workflow

5 Detailed PST Scheduler setup

The details of each work in a setup of PST Scheduler are described below.

5.1 Connection between device and controller (SCS)

The device (valve positioner) which performs PST is connected to a controller (SCS). Refer to Chapter 8 for the connection method.

5.2 Registration to PRM of device

The device needs to be registered into PRM in order to operate a device by PST Scheduler.

1) Set up Device Path

About IO module which connected the device, Device Path is set up with the setup tool of PRM.

2) DD file copy

DD file of a device is copied to the folder of PRM. DD file comes to hand from a vendor. The copy place of a DD file is as follows.

(PRM installation drive)\PRM\DD\HART\Manufacturer ID\Device Type

* Refer to Table 2-1 for Manufacturer ID and Device Type.

3) DTM installation

DTM of an object device is installed. DTM comes to hand from a vendor.

4) Plug & Play Execution

Plug & Play is performed by PRM and a device is registered.

-Trouble Shoot

A device cannot be recognized

->The connection mistake of a device

->The HART module of a valve is not operating since the output to a valve is 0% (less than 4mA).

->0.1% or more (100% recommendation) of the output to a valve is used.

->The address is set as the device.

->The address of a device is changed into 0.

->The range of the polling address of a Device Path setup is extended.

5) Associating the DTM to the device

It is necessary to associate the DTM to the device.

The item “DTM Works...” in the right-click menu at the device is not gray out if the DTM is already associated to the device.

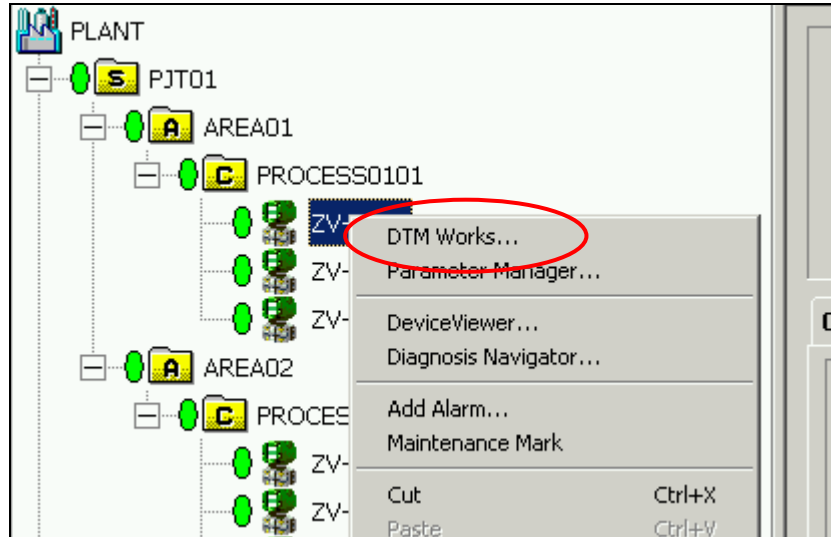

Figure 5-1 Device associated to the DTM

To associate the DTM with device, you must perform the following operations if the DTM is not associated to the device:

- 1) On the left pane of the PRM Setup Tool, expand PRM Client and select [DTM Setup].
- 2) On the right pane, click [Start DTM Setup].
A dialog box appears, asking if you want to update the DTM catalog.
- 3) Click [Yes].
The catalog update process starts. After it completes, the DTM Setup window appears, displaying a list of DTMs installed on the local computer and their device class association.
- 4) Find the DTM that you have just installed by looking at the Name column.
- 5) Associate the DTM to a device class by selecting the appropriate values from the drop-down lists available in the cells under the following columns:
 - Vendor
 - Model
 - Revision
- 6) Click [OK].

You can now use the DTM to configure a device of the corresponding class in PRM Client.

DTM Name	DTM Revision	Comm. Type	DTM Vendor	Vendor	Model	Device Revision
Fisher Controls DVC6000 v02.01	1.4.138.7	HART	Fisher Controls	Fisher Controls	DVC6000	2
Lgx3200MD	5	HART	Flowserve	Flowserve Corporation	0x0005	2
SAMSON 373X-3 (Rev5)	1.44	HART	SAMSON AG	SAMSON AG		
SAMSON 373X-3 (Rev6)	1.51	HART	SAMSON AG	SAMSON AG	3730	6
SVI II ESD HART	203-3.1	HART	Dresser Masonella	Dresser Valve Division	SVI2ESD	1
VG800	2.0	HART	Metso Automation	Metso Automation	ValvGuard	6
VG800	1.0	HART	Metso Automation			

Figure 5-2 Associating the DTM to the device

5.3 Exporting the device list

The device registration to the PST Scheduler is performed through the device list exported from PRM. Follow these steps to export the device list:

- 1) Right-click anywhere in the device list, and select [Export Device List].
Alternatively, from the menu bar, select [File] > [Export] > [Device List].
- 2) In the file selection dialog box, navigate to the location where you want to export the file.
- 3) Type a file name for the device list that you are exporting.
The default file name is "PRMDeviceList.csv".
- 4) Click [Save].
The device list is exported.

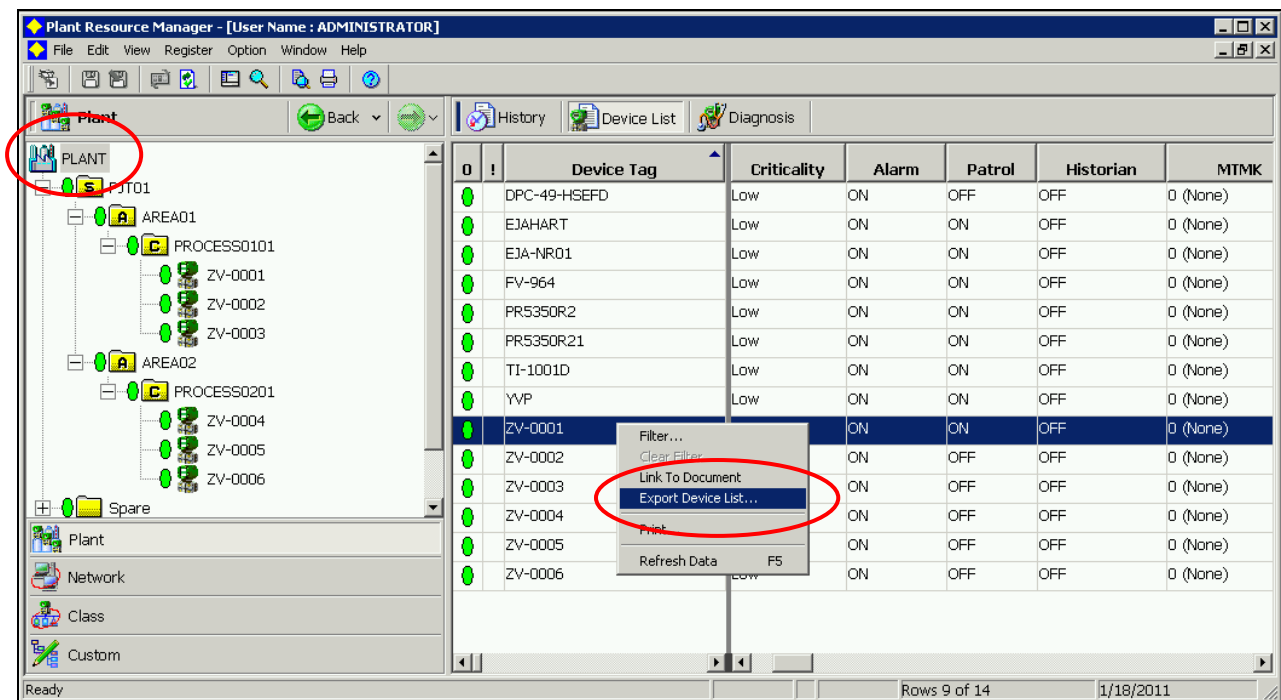

Figure 5-3 Exporting the device list

5.4 Configuring the PST Scheduler Client connection

Follow these steps to configure the PST Scheduler Client connection:

- 1) From your desktop, select [Start] > [All Programs] > [YOKOGAWA PRM] > [Tool] > [PST Scheduler Setup Tool].
The PST Scheduler Setup Tool window appears.
- 2) On the left pane of the PST Scheduler Setup Tool, expand PST Scheduler and select [Connection].
The PST Scheduler Server box appears on the right pane.
- 3) In the PST Scheduler Server box, type the computer name or IP address of the computer installed with the PST Scheduler Server.
- 4) Click [Apply].

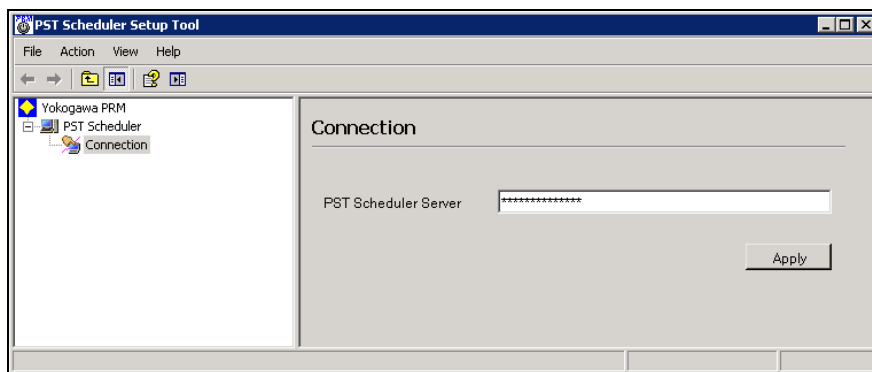

Figure 5-4 PST Scheduler Setup Tool

5.5 Starting the PST Scheduler Client

Follow these steps to start the PST Scheduler Client:

- 1) From your desktop, select [Start] > [All Programs] > [YOKOGAWA PRM] > [PST Scheduler].
The PST Scheduler - Login dialog box appears.
- 2) Login as “Administrator” account.
The passwords for these accounts are the same as the user names.



Figure 5-5 PST Scheduler - Login dialog box

5.6 Importing device information

The device information is imported the device list exported from the PRM Client. Follow these steps to import a CSV file that contains the device information from the PRM system:

- 1) Open the Group Management window.
Click [Configuration] menu, and then click [Device List] icon.

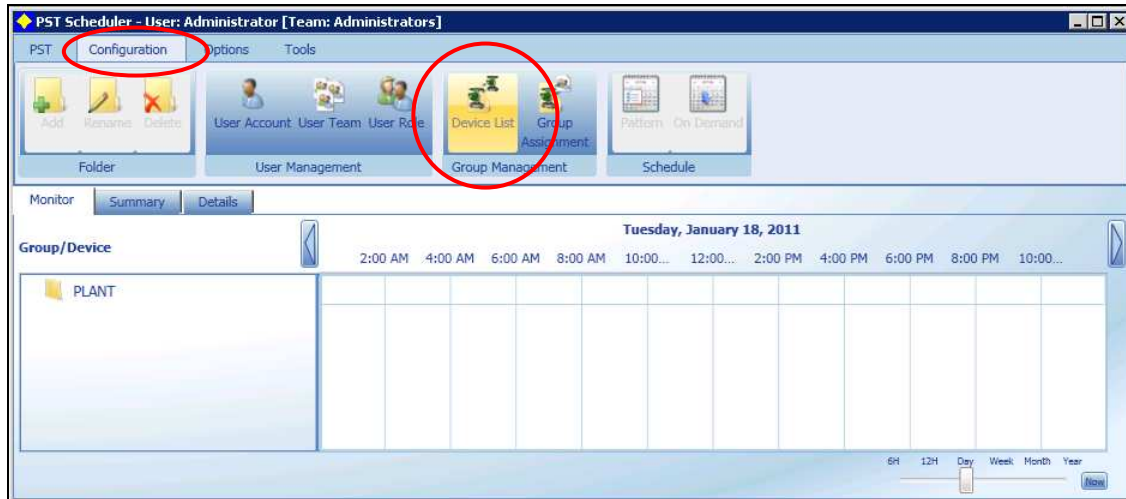

Figure 5-6 Group Management window

- 2) On the Ribbon, click [Import].
The Open dialog box appears.
- 3) Select the CSV file and click [Open] to import the CSV file.



Figure 5-7 Group Management window

- 4) In the dialog box, select the devices to import by performing these steps:
 - (1) In the PRM Server box, type the name or IP address of the computer installed with the PRM

Server.

- (2) In the Field Communication Server box, type the name or IP address of the computer installed with the Field Communications Server.
- (3) From the Device Tag list, select the check boxes of the devices that you want to import.

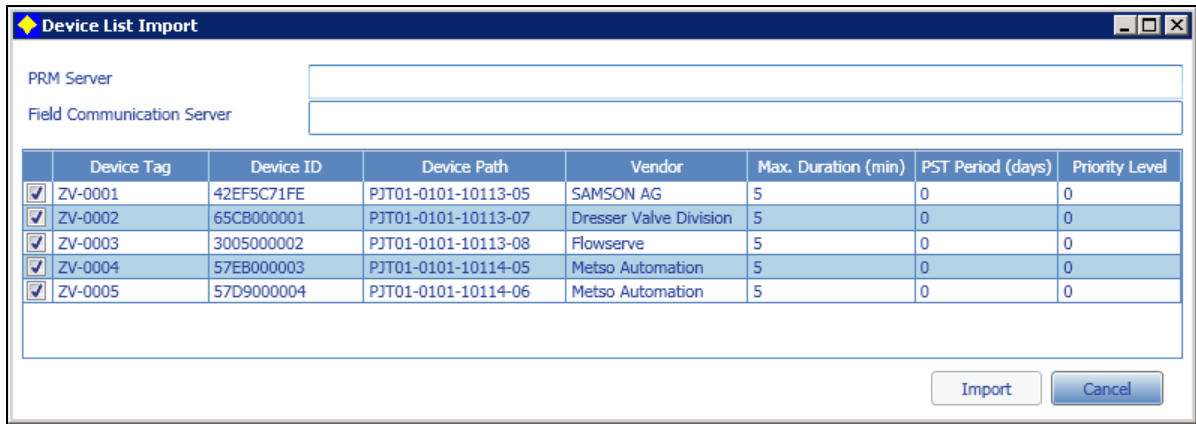

Figure 5-8 Select the devices to import

- 5) Click [Import].

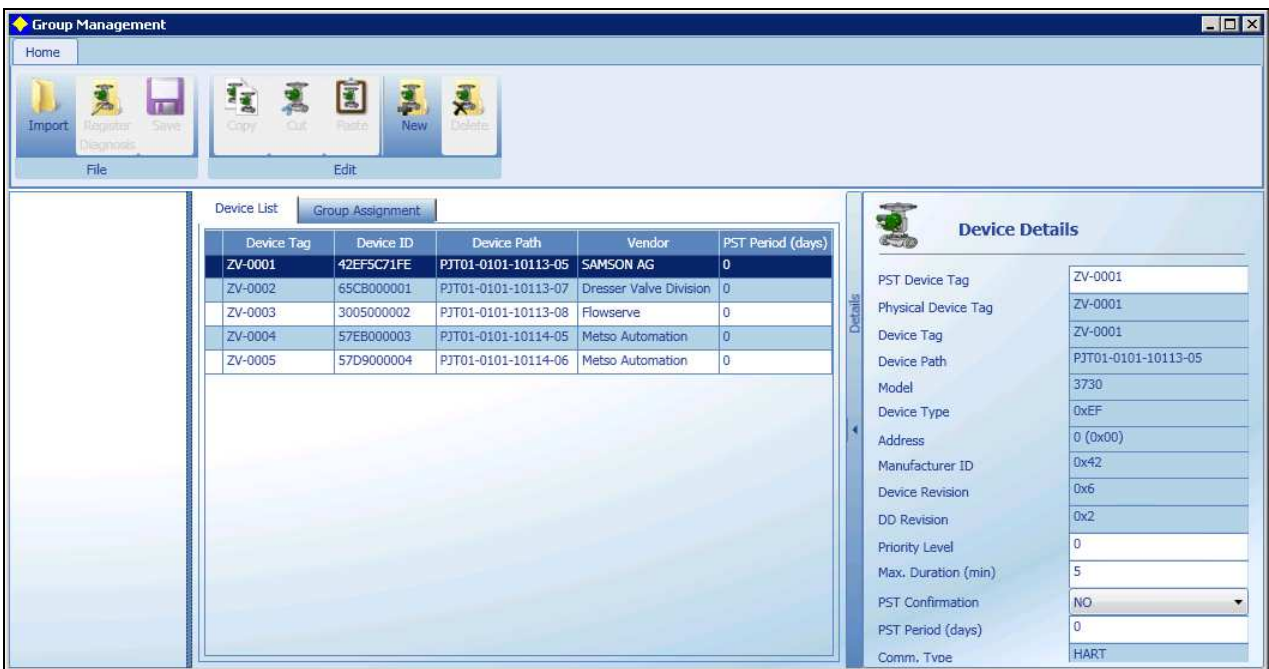

Figure 5-9 Imported devices

5.7 Managing PST groups

It is necessary to create PST group because the PST is scheduled by the group.

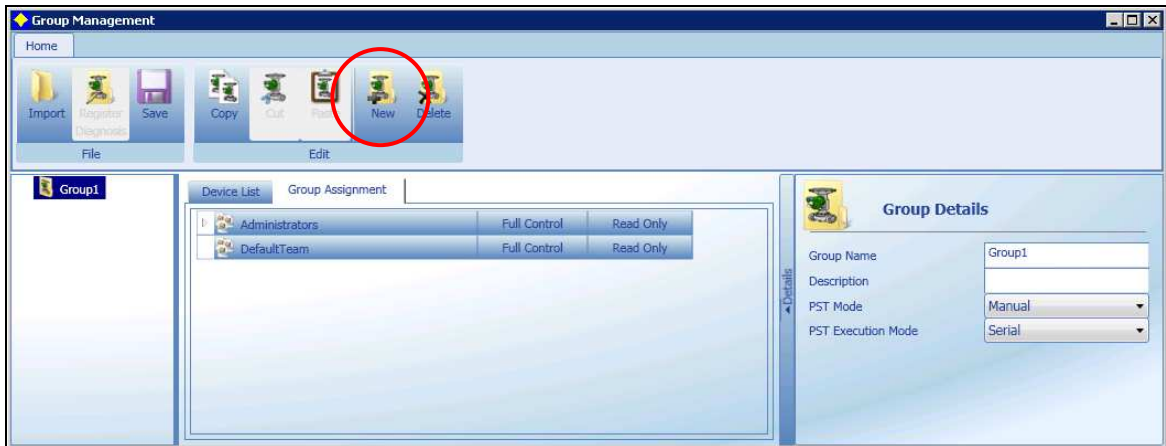

Figure 5-10 Create PST group

5.8 Arranging devices into groups

Drag and drop the selected device(s) into the destination group.

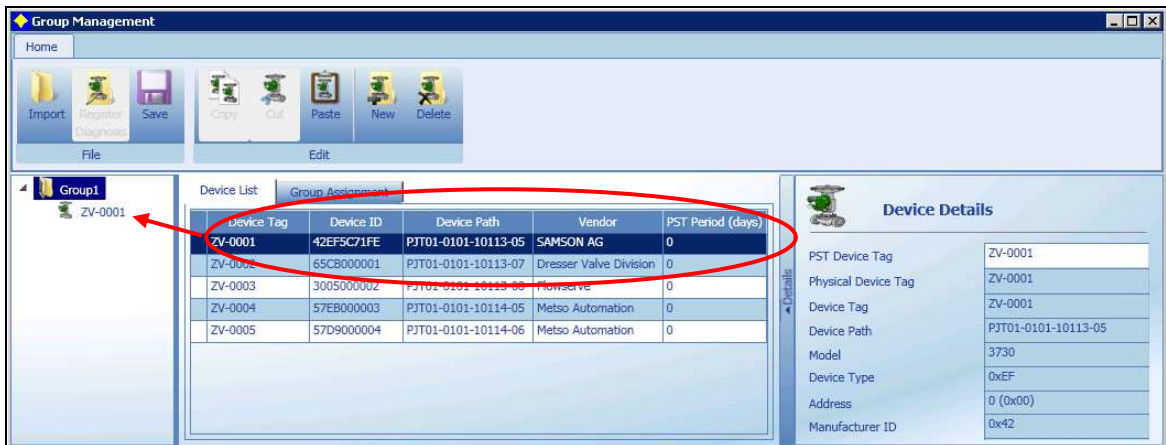

Figure 5-11 Arranging devices into groups

5.9 Scheduling a PST

Configure the PST schedules of a group. Follow these steps to open the PST Group Scheduler dialog box:

- 1) In the Schedule group of the Configuration tab, click, [Pattern] icon
The PST Group Scheduler dialog box appears.

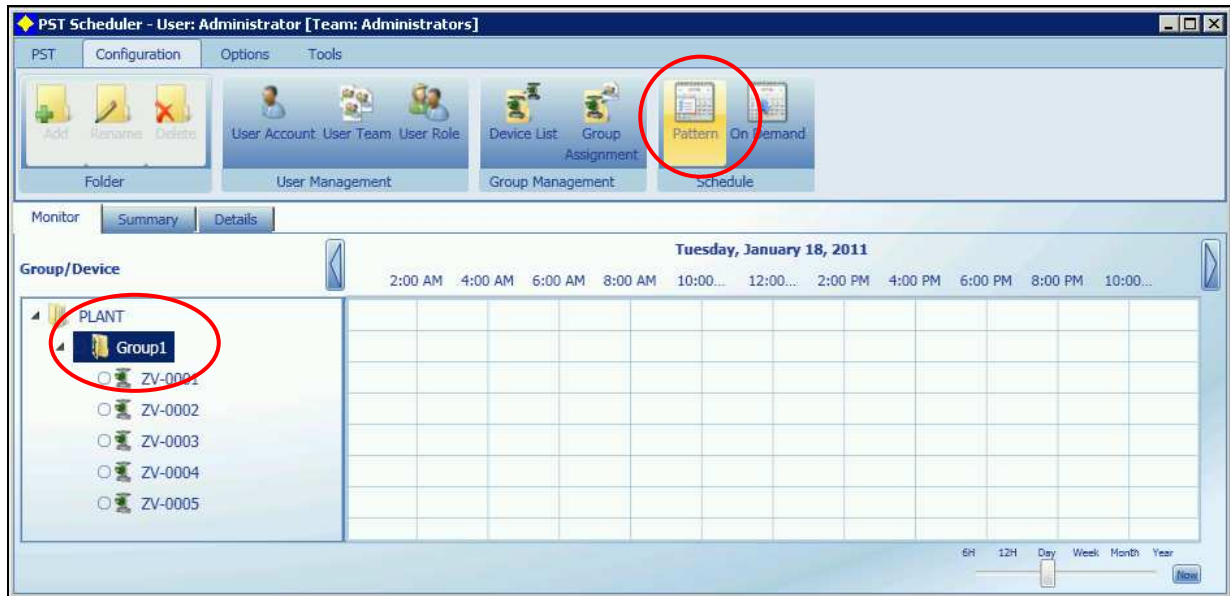

Figure 5-12 PST Group Scheduler dialog box

- 2) Scheduling a pattern PST

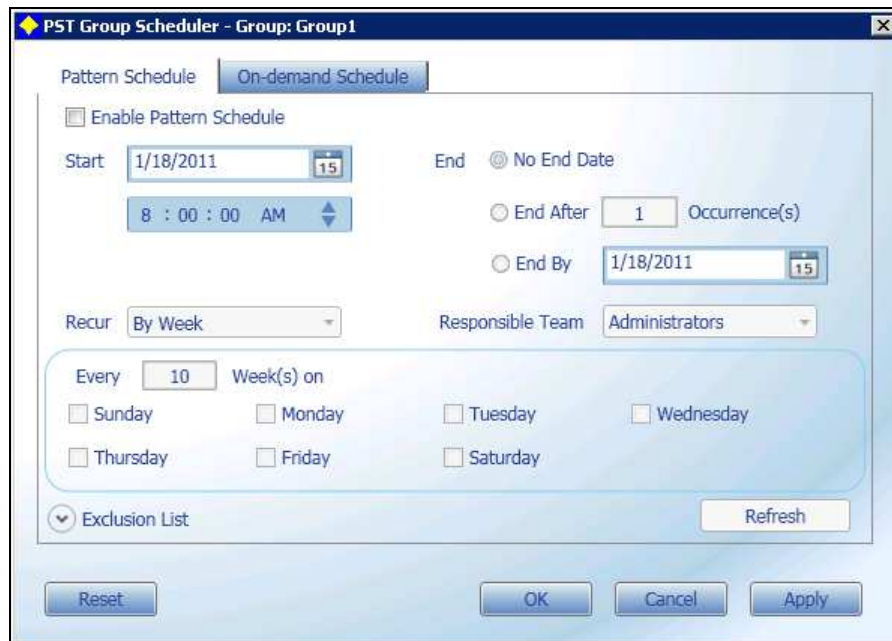

Figure 5-13 Scheduling a pattern PST

- 3) Click [OK].
The PST schedule for the group is displayed in the Monitor tab of the PST Scheduler Client window.

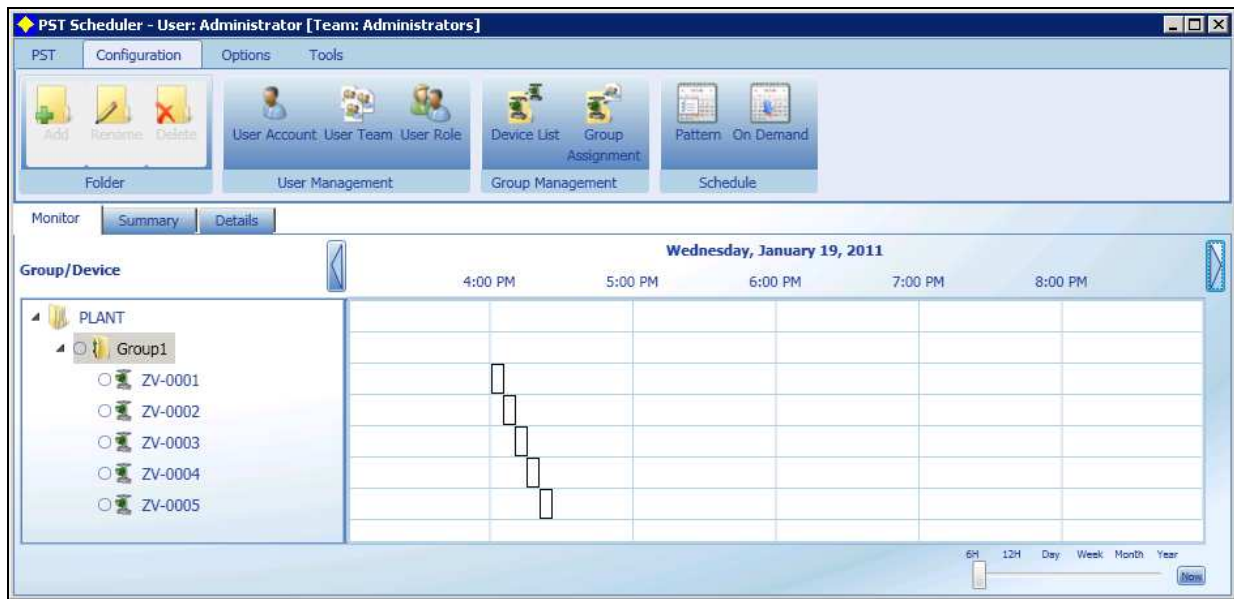

Figure 5-14 Monitor tab of the PST Scheduler Client window

5.10 Check a PST function

Check a PST function. There are the following two methods in execution of a PST function.

- Waiting for the time scheduled the PST function.
- Execution by manual.
Click [Start] in the PST tab of the Ribbon.

5.11 Confirm the status of the PST function in PRM

The status of the PST function can be confirmed as the Maintenance Alarm in PRM.

The screenshot displays the Plant Resource Manager (PRM) interface. The left sidebar shows a tree view of the plant structure, including areas like AREA01 and AREA02, and processes like ZV-0001, ZV-0002, and ZV-0003. The main window shows a 'History' tab with a table of maintenance events. The table has columns for Occurrence Time, Device Tag, Object Criticality, Message Priority, and a description. The details pane below the table shows the following information:

```

<Title(Message Number)>
PST Success(0)

<Model Name(Object Name)>
3730(ZV-0001)

<Location>
DevicePath=PJT01-0101-10113-05

<Problem>
PST Success

<Action>
Action is not required.
For the confirmation, please click to launch PST Scheduler Client.
PST Scheduler Client shows the current status and past history to help your further detail analysis.

<Diag ID>
8

<Diag Name>
PST Scheduler
  
```

The status bar at the bottom indicates 'Rows 1 of 11' and the date '1/19/2011'.

Figure 5-15 Maintenance Alarm

6 The PST setting

The PST Scheduler only transmits a PST execution command to the device. So it is necessary to set up with the parameters of the device for the PST function.

Since these setting are different for every device, refer Chapter 8 for them.

7 The example of PST schedule

The sample setting for the demonstration is given.

7.1 Maximum duration

The “Max. Duration” is the maximum duration is to conduct a PST. Follow these steps to set that:

- 1) Open the Group Management window.
- 2) Select the device, and the input “Max. Duration”.

The maximum of PST execution time is set up here. When the execution time of the PST exceeds the set period of “Max. Duration”, it becomes the end of an error by timeout. The default of “Max. Duration” is 5 (min).

It is necessary to set up this “Max. Duration” according to the device if the execution time of PST is set up for a long time by the configuration of the device,

The screenshot shows the 'Group Management' software interface. On the left, a tree view shows 'Group1' containing devices ZV-0001 through ZV-0005. The main area is divided into a 'Device List' table and a 'Device Details' panel. The 'Device List' table has the following data:

Device Tag	Device ID	Device Path	Vendor	PST Period (days)
ZV-0001	42EF5C71FE	PJT01-0101-10113-05	SAMSON AG	0
ZV-0002	65CB000001	PJT01-0101-10113-07	Dresser Valve Di	0
ZV-0003	3005000002	PJT01-0101-10113-08	Flowserve	0
ZV-0004	57EB000003	PJT01-0101-10114-05	Metso Automatic	0
ZV-0005	57D9000004	PJT01-0101-10114-06	Metso Automatic	0

The 'Device Details' panel for ZV-0001 shows various fields. The 'Max. Duration (min)' field is highlighted with a red circle and contains the value '5'. Other fields include PST Device Tag, Physical Device Tag, Device Tag, Device Path, Model, Device Type, Address, Manufacturer ID, Device Revision, DD Revision, Priority Level, PST Confirmation, PST Period (days), Comm. Type, Vendor, Related Tag, and Maintenance Status.

Figure 7-1 Max. Duration

7.2 PST Mode

There are three kinds of PST Mode, Manual (manual operation), Semi-Auto (semiautomatic), and Auto (automatic). The following operation is performed, when it becomes the scheduled PST execution time.

This setting is chosen at the [PST Mode] in the Group Management window.

Manual:

The PST Scheduler displays a reminder to the user, informing that it is time to perform a scheduled PST. However, the user needs to perform PST for the devices manually.

Semi-Auto:

The PST Scheduler asks for confirmation from the user before it performs a scheduled PST for the group.

Auto:

The PST Scheduler performs a scheduled PST for the group without asking confirmation from the user.

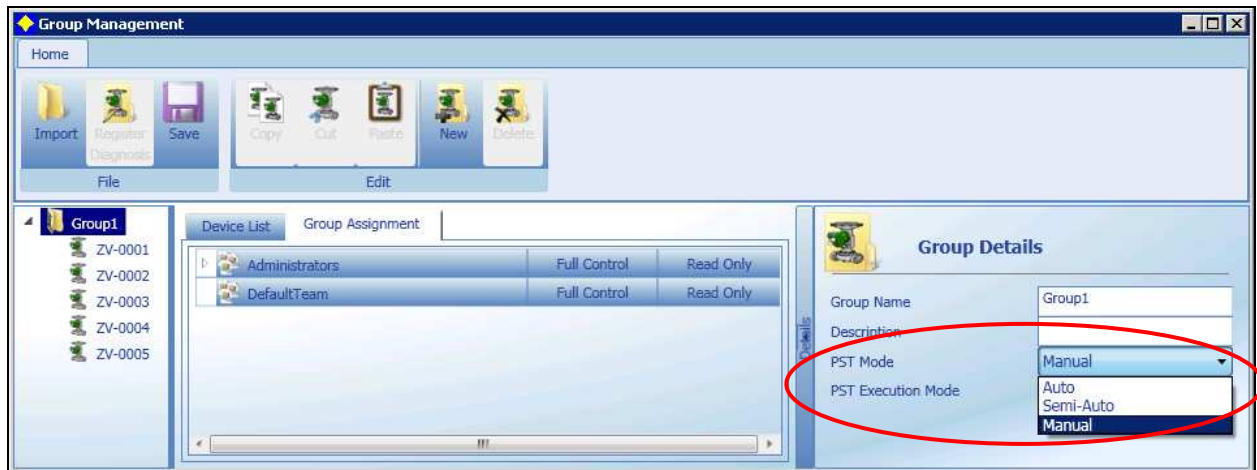

Figure 7-2 PST Mode

7.3 PST Execution Mode

There are two kinds of schedules of PST, Serial and Parallel.

This setting is chosen at the [PST Execution Mode] in the Group Management window.

Serial:

The PST Scheduler performs PST on devices in the group one by one, starting from the top of the list.

Parallel:

The PST Scheduler performs PST on all devices in the group at the same time.

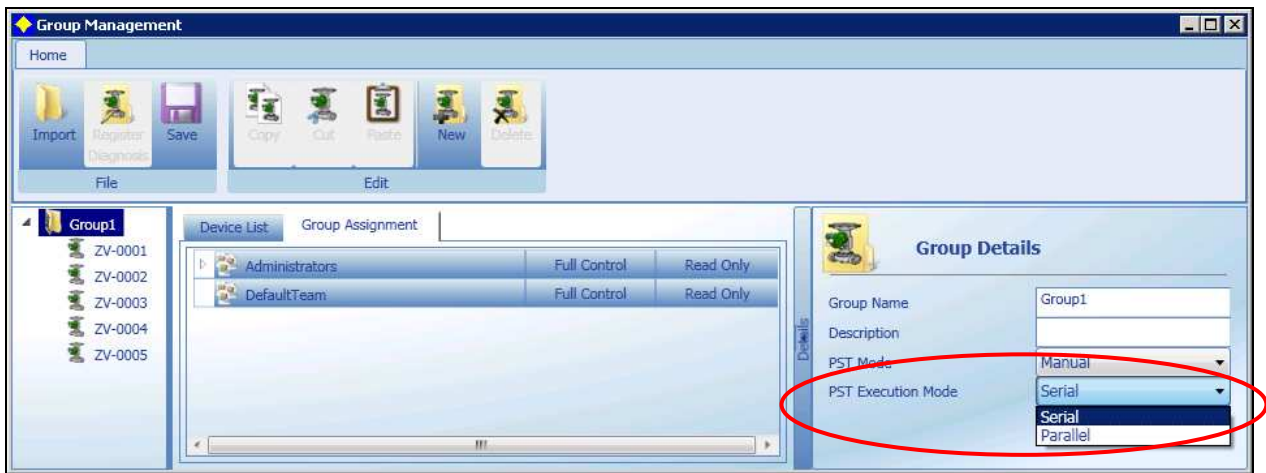

Figure 7-3 PST Execution Mode

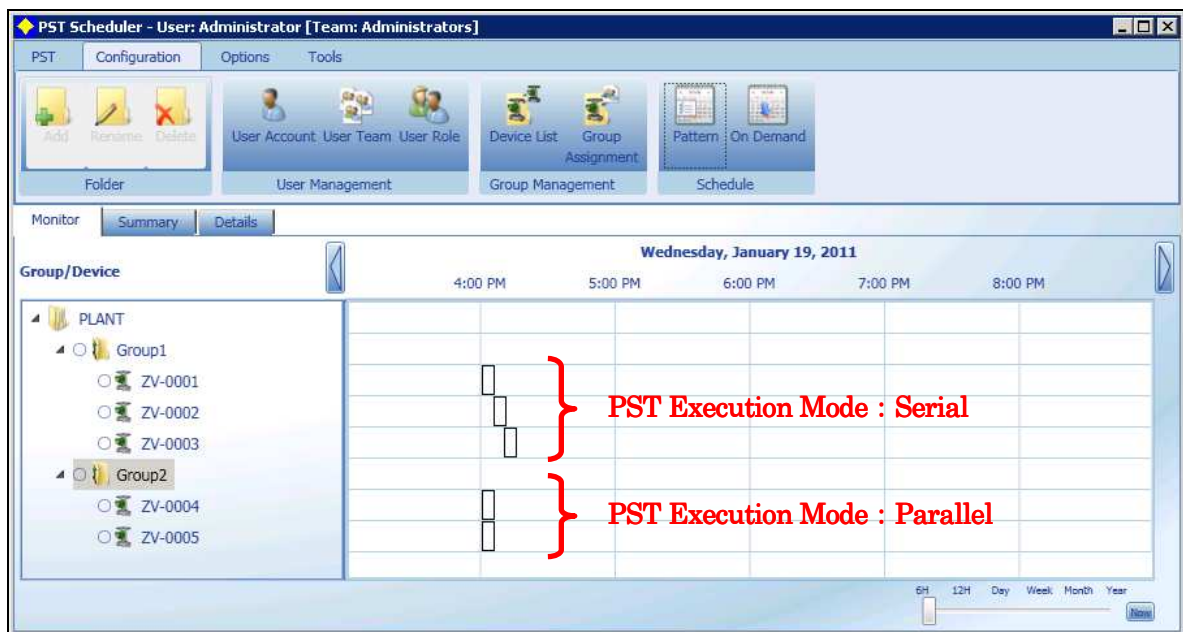

Figure 7-4 Difference in the PST Execution Mode

8 The connection for every device

8.1 Flowserve Logix3200MD

8.1.1 Feature

There are the following features in this device.

ESD:

The positioner is not for the safety system.

The ESD function will operate, if an output is 4mA

SIL:

This device is certified by SIL2.

FST:

It can perform FST (Full Stroke Test) using PST Scheduler if the parameters for working range of PST are set. (Start Position:100%, Stop Position:0%)

Connection between ProSafe-RS and PRM:

HART communication is made by AO module.

Note:

The device usually moves at the Analog command mode (4 - 20mA). But it moves at the Digital command mode (HART communication) after the PST command is received. So the ESD function does not work during the PST function is working.

8.1.2 System configuration

The example of system configuration is as follows.

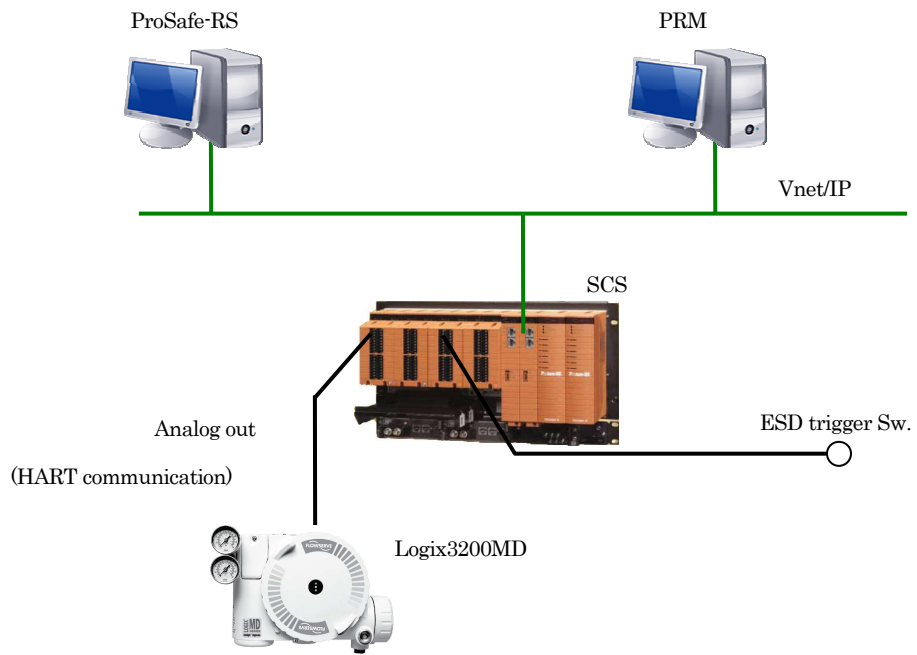

Figure 8-1 System configuration

8.1.3 Equipments list

The equipments for systems configurations are shown in the following table.

Table 8-1 Equipment list

Item	Name	Model / Software revision	Manufacturer	Remark
SCS	Duplexed Safety Control Unit	SSC50D	Yokogawa	Including redundant PSU (100-120VAC) & CPU module
AO (installed in SCS)	16ch Analog Output Module (HART communication)	SAI533-H33	Yokogawa	With Hart communication
Logix3200MD	Partial Stroke Test device	Logix3200MD	Flowserve	
(SENG)	ProSafe-RS software	R1.02.00	Yokogawa	
(PRM)	PRM software	R3.04.00	Yokogawa	Including DTM works
(PRM)	DTM software	Logix3200MD/Rev5	Flowserve	

8.1.4 DTM

DTM used for the combination test with PST Scheduler is shown in the following table.

Table 8-2 Logix3200MD DTM

Vendor	Device Model	Protocol	DTM Version	Manufacturer ID	Device Type	Device Rev.
Flowserve	Logix3200MD	HART	5	0x30	0x0005	2

It is necessary to obtain this DTM from the Flowserve.

The DTM is for a fee.

In order to register this DTM into PRM, it sets up as follows by DTM Browser.

DTM Name	DTM Revision	Comm. Type	DTM Vendor	Vendor	Model	Device Revision
Fisher Controls DVC6000 v02.01	1.4.138.7	HART	Fisher Controls	Fisher Controls	DVC6000	2
Lgx3200MD	5	HART	Flowserve	Flowserve Corporation	0x0005	2
SAMSON 373X-3 (Rev5)	1.44	HART	SAMSON AG	SAMSON AG	3730	6
SAMSON 373X-3 (Rev6)	1.51	HART	SAMSON AG	SAMSON AG	3730	6
SVII ESD HART	203-3.1	HART	Dresser Masoneilan	Dresser Valve Division	SVI2ESD	1
VG800	2.0	HART	Metso Automation	Metso Automation	ValvGuard	6
VG800	1.0	HART	Metso Automation	Metso Automation	ValvGuard	6

8.1.5 Wiring

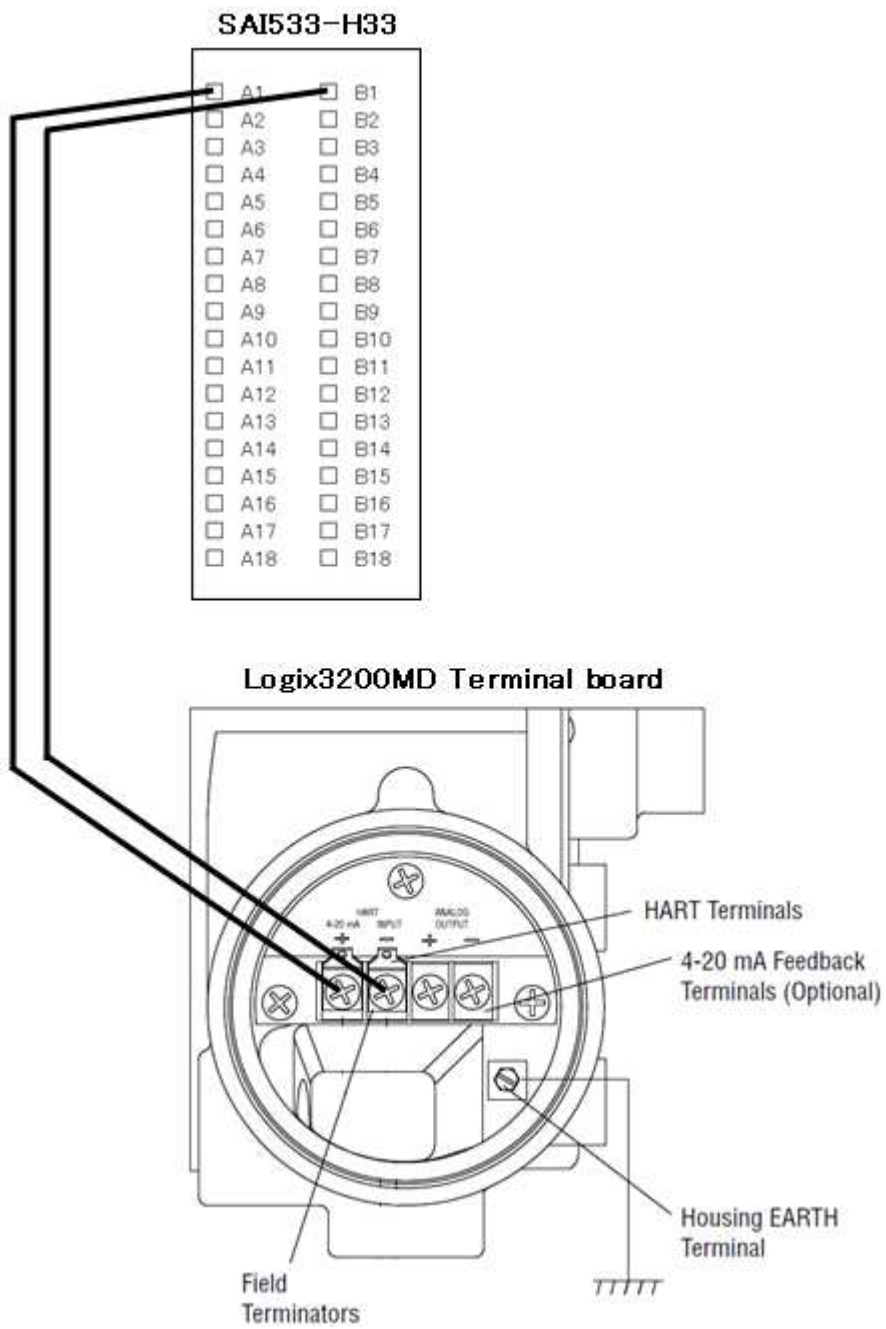

Figure 8-2 Wiring

8.1.6 Application

The example of an application with Yokogawa ProSafe-RS is as follows.
The ESD function will operate, if the DI (ex. DI010301) is true.

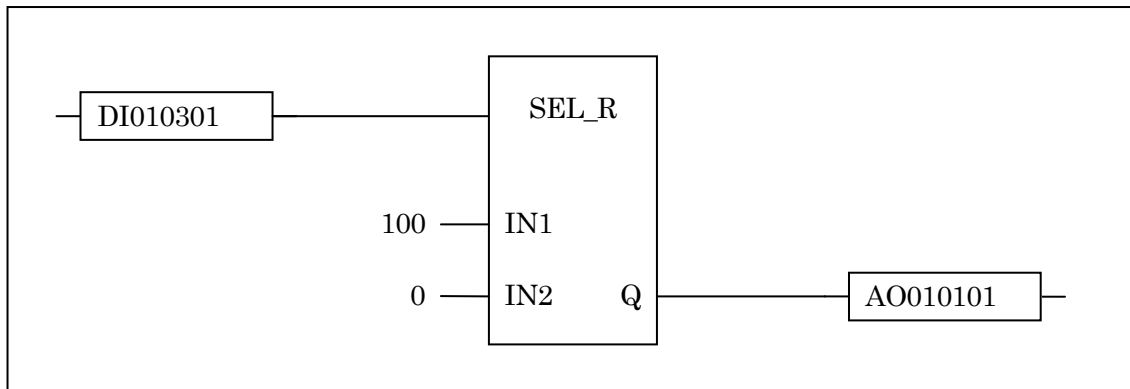

Figure 8-3 Application

8.1.7 PST related parameter

The PST related parameters and their recommended value are as follows.

Table 8-3 PST related parameter

Parameter	Recommended value	
Start Position	95 %	The start position of PST (%)
Stop Position	80 %	The stop position of PST (%)
Time to Target	20 sec	The time to move to the stop position form the start position (sec)
Test Duration	50sec	PST execution time (sec)

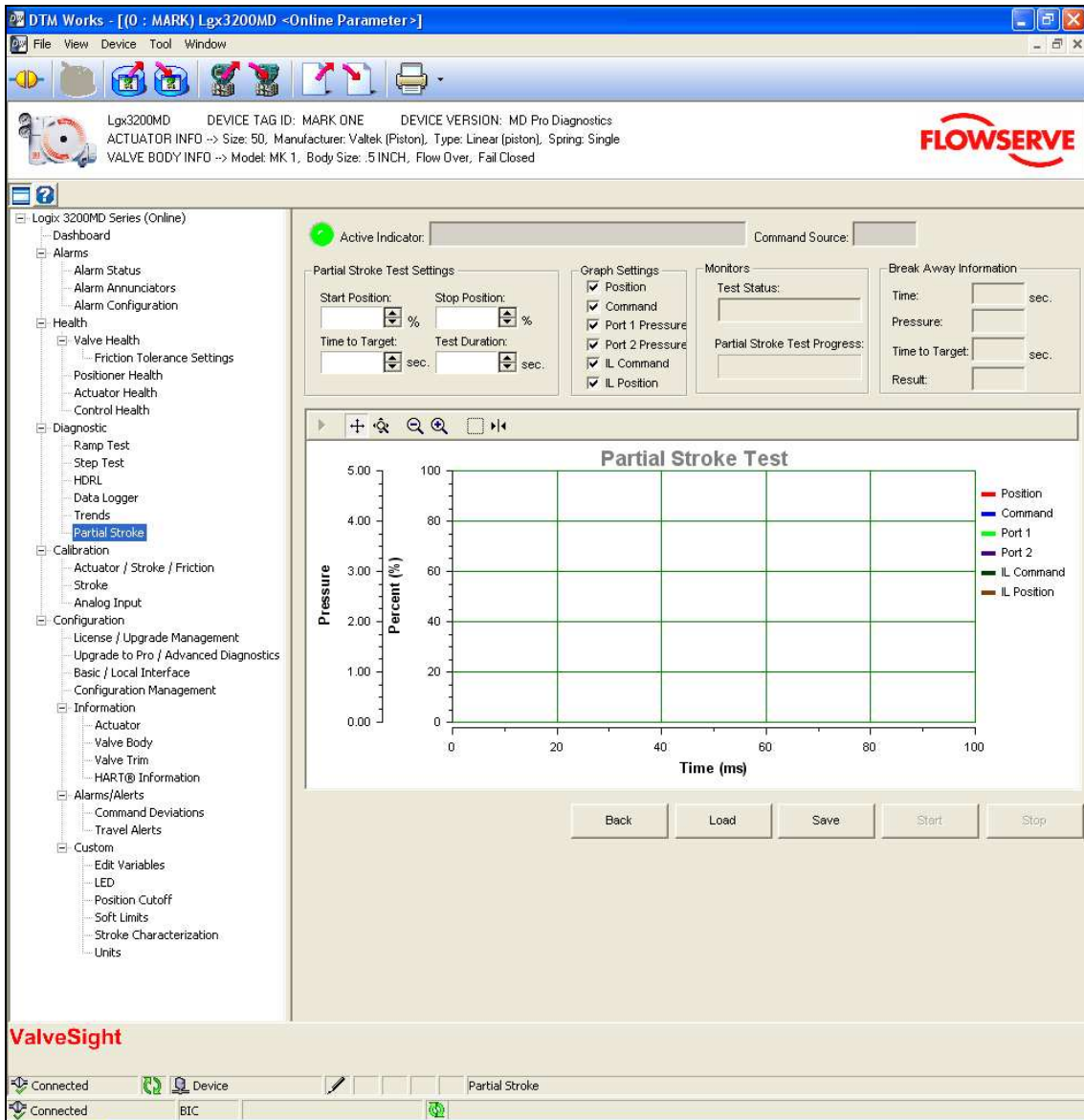

Figure 8-4 DTM

8.1.8 Valve operation in PST

Valve operation in PST is as follows.

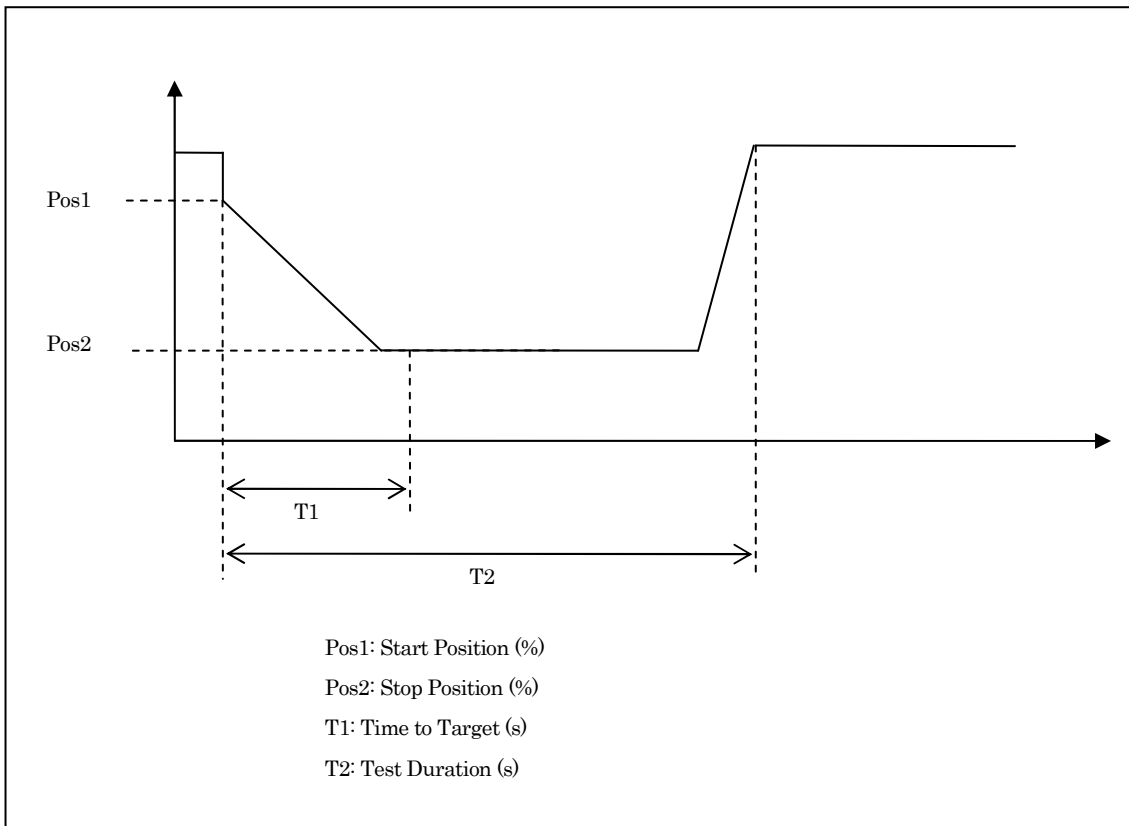

Figure 8-5 Valve operation in PST