

Drawings

AXF025, AXF032, AXF040, AXF050 AXF Integral Flowmeter/Remote Flowtube AXF Standard (DIN Flange)



Fluorocarbon PFA/Polyurethane Rubber/Natural Soft Rubber/EPDM Rubber Lining

Integral Flowmeter Remote Flowtube Integral Flowmeter Remote Flowtube

Unit : mm
(approx. inch)

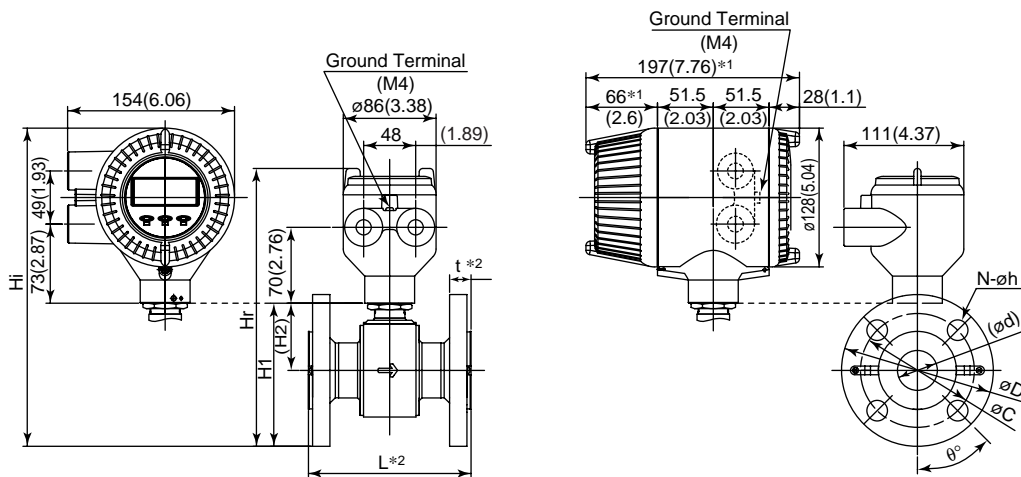

Fig11E.EPS

*No infra-red switches are furnished for Fieldbus communication type.

Model code:

AXF025 G ^{*5} D E 1 A
AXF032 W F 2 U
AXF040 C G N
AXF050 P

□ 1 □ - B D 4 1
□ 2 □ - C D 4 1

*5: D, E, F, G; Integral Flowmeter, N, P: Remote Flowtube

* When option code RA, RB, or RC is selected, the direction of electrical connection change as below.

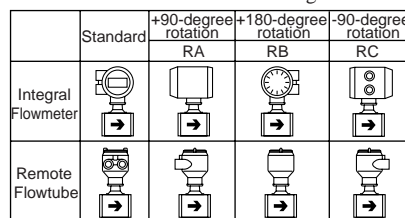

F19-1E.EPS

*1: When indicator code N is selected, subtract 12mm(0.47inch) from the value in the figure. In case of explosion proof type with indicator, add 5 mm (0.2 inch) to it.

*2: Depending on the selection of grounding ring code and optional code, add the following value to "L"(face-to-face length) and "t"(thickness of flange).

Grounding Ring Code	L		t		L		t	
	S, L, H, V	P, T	N					
Option Code	None	+0	+0	+26(1.02)	+13(0.51)	-2(0.08)	-1(0.04)	
GA, GC, GD (Special Gaskets)	+8(0.31)	+4(0.16)	+30(1.18)	+15(0.59)	-	-		

*3: When submersible type or option code DHC is selected, waterproof glands and a 30m long cable are attached. Add 9.5kg(20.9lb) to the weight in the table.

Model	Process Connection	BD4(DIN PN40)			BD4/CD4 (DIN PN40)
	Size code	025	032	040	050
	Size	25 (1)	32 (1.25)	40 (1.5)	50 (2)
	Lining code	A,U	A,U	A,U	A,U D,G
Remote Flowtube	Face-to-face length L ₃ ^{*2}	200 (7.87)	200 (7.87)	200 (7.87)	200 (7.87)
	Outside dia. øD	115 (4.53)	140 (5.51)	150 (5.91)	165 (6.50)
	Thickness t ^{*2}	22 (0.87)	22 (0.87)	22 (0.87)	24 (0.94)
	Inner diameter of Grounding ring ød	28 (1.10)	34 (1.34)	41 (1.61)	53 (2.09)
	Pitch circle dia. øC	85 (3.35)	100 (3.94)	110 (4.33)	125 (4.92)
	Bolt hole interval θ°	45	45	45	45
Integral Flowmeter	Hole dia. øh	14 (0.55)	18 (0.71)	18 (0.71)	18 (0.71)
	Number of holes N	4	4	4	4
	Height H1	115 (4.54)	131 (5.16)	143 (5.63)	162 (6.36)
	Height H2	58 (2.28)	61 (2.40)	68 (2.67)	79 (3.11)
Remote Flowtube	Max. Height Hr	239 (9.42)	255 (10.04)	267 (10.51)	286 (11.24)
	Weight kg (lb) ^{*3}	4.7 (14.1)	6.1 (17.2)	6.9 (19.0)	8.7 (22.9)
Integral Flowmeter	Max. Height Hi	277 (10.90)	293 (11.54)	304 (11.98)	323 (12.72)
	Weight kg (lb)	6.4 (10.4)	7.8 (13.4)	8.6 (15.2)	10.4 (19.2)

TD13E.EPS

Lining code : A; Fluorocarbon PFA, U; Polyurethane Rubber
D; Natural Soft Rubber, G; EPDM Rubber

Unless otherwise specified, difference in the dimensions are specified as : General tolerance = ± (Criteria of tolerance class IT18 in JIS B0401) / 2

Integral Flowmeter

BRAIN/HART Communication Type

Terminal configuration

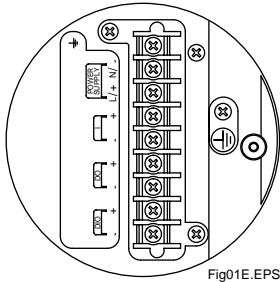

Fig01E.EPS

Terminal wiring

Terminal Symbols	Description
	Functional grounding
N/- L/+	Power supply
I+ I-	Current output 4 to 20mA DC
DO+ DO-	Pulse output/Alarm output/ Status output
DIO+ DIO-	Alarm output/Status output Status input
	Protective grounding (Outside of the terminal)

Fig01-2E.EPS

Remote Flowtube

Terminal configuration

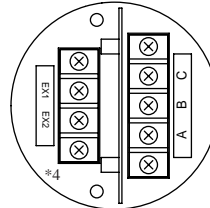

*4: In case of explosion proof type, (functional grounding terminal) is added.

Fig02E.EPS

Terminal wiring

Terminal Symbols	Description
A B C	Flow signal output
EX1 EX2	Excitation current input
	Protective grounding (Outside of the terminal)

FOUNDATION Fieldbus/PROFIBUS PA Communication type

Terminal configuration

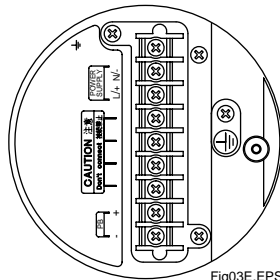

Fig03E.EPS

Terminal wiring

Terminal Symbols	Description
	Functional grounding
N/- L/+	Power supply
FB+ FB-	Fieldbus communication signal
	Protective grounding (Outside of the terminal)

Fig01-3E.EPS