

Integral Flowmeter Remote Flowtube

Integral Flowmeter Remote Flowtube

Unit : mm  
(approx. inch)

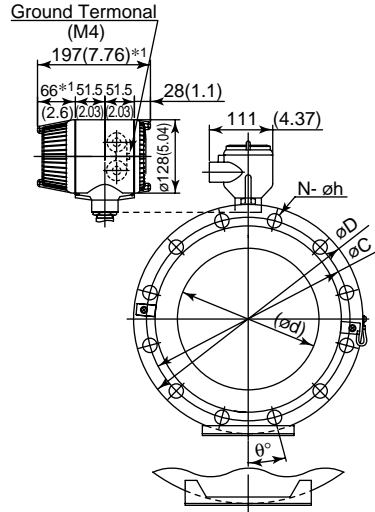
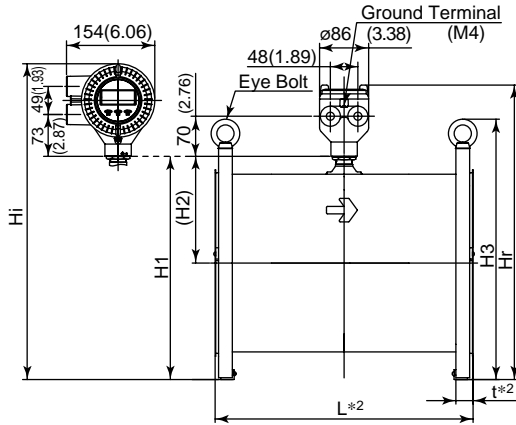

for AXF300, AXF350, AXF400

Fig14E.EPS

\*No infra-red switches are furnished for Fieldbus communication type.

#### Model code:

AXF250 G  
AXF300 W  
AXF350 C  
AXF400 C

D<sup>\*5</sup> A  
E 1 U  
F 2 D  
G N  
P

□ 1 □ 2 □ 1

B A □  
C A □ 1

\*5: D, E, F, G; Integral Flowmeter, N, P: Remote Flowtube

Model	Process Connection		BA1/CA1 (ANSI Class 150)				BA2/CA2 (ANSI Class 300)	
	Size code		250	300	350	400	250	300
	Size		250 (10)	300 (12)	350 (14)	400 (16)	250 (10)	300 (12)
	Lining code		A, U, D, G	A, U, D, G	A, U, D, G	A, U, D, G	A, U, D, G	A, U, D, G
Remote Flowtube	Face-to-face length	L <sup>*2</sup>	450 (17.72)	500 (19.69)	550 (21.65)	600 (23.62)	450 (17.72)	500 (19.69)
	Outside dia.	øD	406.4 (16.00)	482.6 (19.00)	533.4 (21.00)	596.9 (23.50)	444.5 (17.50)	520.7 (20.50)
	Thickness	t <sup>*2</sup>	38.2 (1.50)	39.8 (1.57)	45.1 (1.78)	46.6 (1.83)	55.7 (2.19)	58.8 (2.31)
	Inner diameter of Grounding ring	ød	243 (9.57)	291.3 (11.47)	323.4 (12.73)	373.5 (14.70)	243 (9.56)	291.3 (11.47)
	Pitch circle dia.	øC	362.0 (14.25)	431.8 (17.00)	476.3 (18.75)	539.8 (21.25)	387.4 (15.25)	450.9 (17.75)
Integral Flowmeter	Bolt hole interval	θ°	15	15	15	11.25	11.25	11.25
	Hole dia.	øh	25.4 (1.00)	25.4 (1.00)	28.4 (1.12)	28.4 (1.12)	28.4 (1.12)	31.8 (1.25)
	Number of holes	N	12	12	12	16	16	16
	Height	H1	403 (15.87)	466 (18.35)	512 (20.16)	572 (22.52)	422 (16.61)	485 (19.09)
Remote Flowtube	Height	H2	197 (7.76)	221 (8.70)	243 (9.57)	270 (10.63)	197 (7.76)	221 (8.70)
	Height	H3	460 (18.11)	537 (21.14)	596 (23.46)	660 (25.98)	499 (19.65)	575 (22.64)
	Max. Height	Hr	527 (20.75)	590 (23.23)	636 (25.04)	696 (27.40)	546 (21.50)	609 (23.98)
Integral Flowmeter	Weight kg (lb) <sup>*3</sup>		83.4 (183.8)	104.8 (231.0)	151.8 (334.7)	185.3 (408.5)	133.0 (293.1)	176.7 (389.5)
	Max. Height	Hi	565 (22.24)	628 (24.72)	674 (26.54)	734 (28.90)	584 (22.99)	647 (25.47)
	Weight kg (lb)		85.1 (187.6)	106.5 (234.8)	153.5 (338.4)	187.0 (412.3)	134.7 (296.9)	178.4 (393.3)

Lining code : A; Fluorocarbon PFA, U; Polyurethane Rubber  
D; Natural Soft Rubber, G; EPDM Rubber

TD02-14E.EPS

\* When option code RA, RB, or RC is selected, the direction of electrical connection change as below.

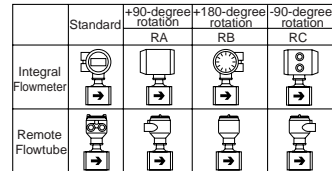

F19-1E.EPS

\*1: When indicator code N is selected, subtract 12mm(0.47inch) from the value in the figure. In case of explosion proof type with indicator, add 5 mm (0.2 inch) to it.  
\*2: Depending on the selection of grounding ring code and optional code, add the following value to "L"(face-to-face length) and "t"(thickness of flange).

Nominal Size: 250mm to 300mm				
	L	t	L	t
Grounding Ring Code	S, L, H, V		N	
Option Code is "None"	+0	+0	-6(0.24)	-3(0.12)

Nominal Size: 350mm to 400mm				
	L	t	L	t
Grounding Ring Code	S, L, H, V		N	
Option Code is "None"	+0	+0	-10(0.39)	-5(0.20)

\*3: When submersible type or option code DHC is selected, waterproof glands and a 30m long cable are attached. Add 9.5kg(20.9lb) to the weight in the table.

Unless otherwise specified, difference in the dimensions are specified as : General tolerance = ± (Criteria of tolerance class IT18 in JIS B0401) / 2

## Integral Flowmeter

### BRAIN/HART Communication Type

#### Terminal configuration

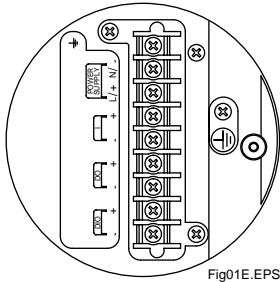

Fig01E.EPS

#### Terminal wiring

Terminal Symbols	Description
	Functional grounding
N/- L/+	Power supply
I+ I-	Current output 4 to 20mA DC
DO+ DO-	Pulse output/Alarm output/ Status output
DIO+ DIO-	Alarm output/Status output Status input
	Protective grounding (Outside of the terminal)

Fig01-2E.EPS

## Remote Flowtube

#### Terminal configuration

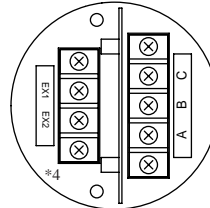

\*4: In case of explosion proof type, (functional grounding terminal) is added.

Fig02E.EPS

#### Terminal wiring

Terminal Symbols	Description
A B C	Flow signal output
EX1 EX2	Excitation current input
	Protective grounding (Outside of the terminal)

### FOUNDATION Fieldbus/PROFIBUS PA Communication type

#### Terminal configuration

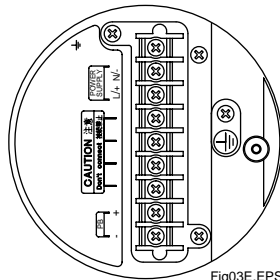

Fig03E.EPS

#### Terminal wiring

Terminal Symbols	Description
	Functional grounding
N/- L/+	Power supply
FB+ FB-	Fieldbus communication signal
	Protective grounding (Outside of the terminal)

Fig01-3E.EPS