

### AXF Integral Flowmeter/Remote Flowtube Replacement Model for Earlier ADMAG or ADMAG AE (JIS Flange) Fluorocarbon PFA/Polyurethane Rubber Lining

Integral Flowmeter    Remote Flowtube

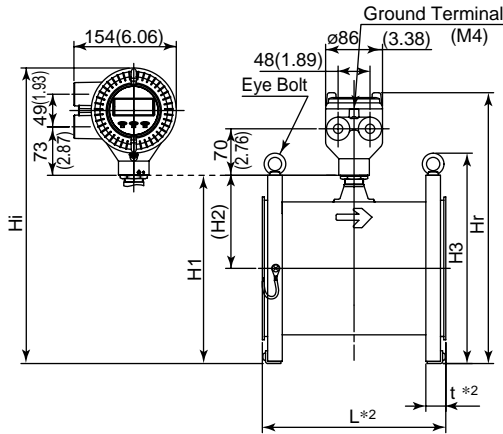

Integral Flowmeter    Remote Flowtube

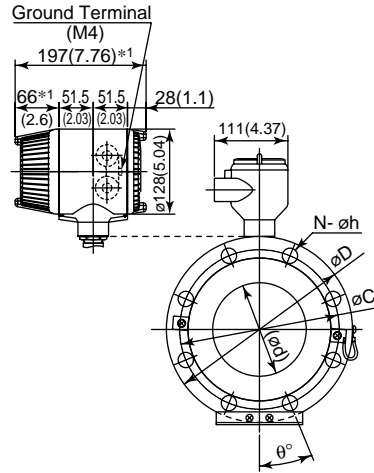

Unit : mm  
(approx. inch)

Fig15E.EPS

\*No infla-red switches are furnished for Fieldbus communication type.

#### Model code:

$\begin{matrix} D \\ E \\ F \\ G \\ N \\ P \end{matrix}^{*5}$   
 AXF150 G — A U □ 1 □ — C J □ 2  
 AXF200 W — F 2 □ 1 □ — C G □ 2  
 AXF250 C — G N □ 2 □ — C G □ 2

\*5: D, E, F, G; Integral Flowmeter, N, P: Remote Flowtube

\* When option code RA, RB, or RC is selected, the direction of electrical connection change as below.

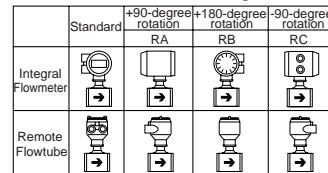

F19-1E.EPS

- \*1: When indicator code N is selected, subtract 12mm(0.47inch) from the value in the figure. In case of explosion proof type with indicator, add 5 mm (0.2 inch) to it.
- \*2: Depending on the selection of grounding ring code and optional code, add the following value to "L"(face-to-face length) and "t"(thickness of flange).

Nominal Size: 150, 200mm						
Grounding Ring Code	S, L, H, V		P, T		N	
	Option Code	None	+0	+0	+28(1.1)	+14(0.55)
	GA, GC, GD (Special Gaskets)	+2(0.08)	+1(0.04)	+30(1.18)	+15(0.59)	-

Nominal Size: 250mm				
Grounding Ring Code	S, L, H, V		N	
	Option Code is "None"	+0	+0	-6(0.24)

- \*3: When submersible type or option code DHC is selected, waterproof glands and a 30m long cable are attached. Add 9.5kg(20.9lb) to the weight in the table.

Model	Process Connection		CJ1(JIS10K)			CJ2(JIS20K)			CG1(JISF12)		
	Size code		150	200	250	150	200	250	150	200	250
	Size		150 (6)	200 (8)	250 (10)	150 (6)	200 (8)	250 (10)	150 (6)	200 (8)	250 (10)
	Lining code		A,U	A,U	A,U	A,U	A,U	A,U	A,U	A,U	A,U
Remote Flowtube	Face-to-face length	L *2	270 (10.63)	340 (13.39)	430 (16.93)	270 (10.63)	340 (13.39)	430 (16.93)	270 (10.63)	340 (13.39)	430 (16.93)
	Outside dia.	øD	280 (11.02)	330 (12.99)	400 (15.75)	305 (12.01)	350 (13.78)	430 (16.93)	290 (11.42)	342 (13.46)	410 (16.14)
	Thickness	t *2	31 (1.22)	31 (1.22)	33 (1.30)	37 (1.46)	39 (1.54)	43 (1.69)	31 (1.22)	33 (1.30)	33 (1.30)
	Inner diameter of Grounding ring	ød	140.7 (5.54)	188.9 (7.44)	243 (9.57)	140.7 (5.54)	188.9 (7.44)	243 (9.57)	145.4 (5.72)	192.9 (7.59)	243 (9.57)
	Pitch circle dia.	øC	240 (9.45)	290 (11.42)	355 (13.98)	260 (10.24)	305 (12.01)	380 (14.96)	247 (9.72)	299 (11.77)	360 (14.17)
	Bolt hole interval	θ°	22.5	15	15	15	15	15	30	22.5	22.5
Integral Flowmeter	Hole dia.	øh	23 (0.91)	23 (0.91)	25 (0.98)	25 (0.98)	25 (0.98)	27 (1.06)	19 (0.75)	19 (0.75)	23 (0.91)
	Number of holes	N	8	12	12	12	12	12	6	8	8
	Height	H1	284 (11.18)	334 (13.15)	400 (15.75)	297 (11.69)	344 (13.54)	415 (16.34)	289 (11.38)	340 (13.39)	405 (15.94)
	Height	H2	141 (5.55)	166 (6.54)	197 (7.76)	141 (5.55)	166 (6.54)	197 (7.76)	141 (5.55)	166 (6.54)	197 (7.76)
Remote Flowtube	Height	H3	325 (12.80)	375 (14.76)	454 (17.87)	350 (13.78)	395 (15.55)	484 (19.06)	335 (13.19)	387 (15.24)	464 (18.27)
	Max. Height	Hr	408 (16.06)	458 (18.03)	524 (20.63)	421 (16.57)	468 (18.43)	539 (21.22)	413 (16.26)	464 (18.27)	529 (20.83)
Integral Flowmeter	Weight kg (lb) *3		29 (63.9)	39 (86.0)	64 (141.1)	38.3 (84.4)	53.6 (118.2)	92.5 (203.9)	31.1 (68.6)	44.6 (98.3)	67.4 (148.6)
	Max. Height	Hi	446 (17.56)	496 (19.53)	562 (22.13)	459 (18.07)	506 (19.92)	577 (22.72)	451 (17.76)	502 (19.76)	567 (22.32)
	Weight kg (lb)		30.7 (67.7)	40.7 (89.7)	65.7 (144.8)	40.0 (88.2)	55.3 (121.9)	94.2 (207.7)	32.8 (72.3)	46.3 (102.1)	69.1 (152.3)

T02-20E.EPS

Lining code : A; Fluorocarbon PFA, U; Polyurethane Rubber

Unless otherwise specified, difference in the dimensions are specified as : General tolerance = ± (Criteria of tolerance class IT18 in JIS B0401) / 2

## Integral Flowmeter

### BRAIN/HART Communication Type

#### Terminal configuration

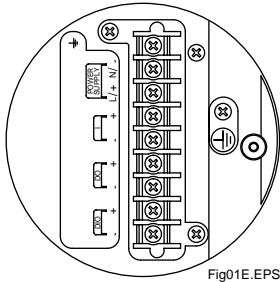

Fig01E.EPS

#### Terminal wiring

Terminal Symbols	Description
	Functional grounding
N/- L/+	Power supply
I+ I-	Current output 4 to 20mA DC
DO+ DO-	Pulse output/Alarm output/ Status output
DIO+ DIO-	Alarm output/Status output Status input
	Protective grounding (Outside of the terminal)

Fig01-2E.EPS

## Remote Flowtube

#### Terminal configuration

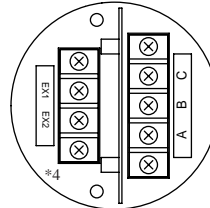

\*4: In case of explosion proof type, (functional grounding terminal) is added.

Fig02E.EPS

#### Terminal wiring

Terminal Symbols	Description
A B C	Flow signal output
EX1 EX2	Excitation current input
	Protective grounding (Outside of the terminal)

### FOUNDATION Fieldbus/PROFIBUS PA Communication type

#### Terminal configuration

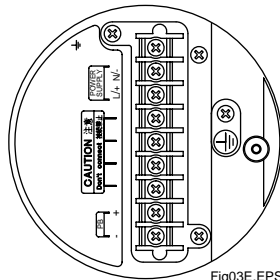

Fig03E.EPS

#### Terminal wiring

Terminal Symbols	Description
	Functional grounding
N/- L/+	Power supply
FB+ FB-	Fieldbus communication signal
	Protective grounding (Outside of the terminal)

Fig01-3E.EPS