

Model DY
Vortex Flowmeter
Model DYA
Vortex Flow Converter
Fieldbus Communication Type



Please use the attached sheets for the pages listed below in IM 1F6F0-01E. (5th)

Page and Item	Contents of Correction
Chapter 9: Page 9-1 to 9-5 Chapter 10: Page 10-1 to 10-11	Temperature specification change and corrections

9. GENERAL SPECIFICATIONS

9.1 Standard Specifications

For items other than those described below, refer to GS 01F06A00-01EN.

Applicable Models:

All the models of DY and DYA with Fieldbus communication functions (Output code: F). These models conform to the following EMC conformity standards:

EN61326-1 Class A, Table 2 (For use in industrial locations), EN61326-2-3

EN55011 Class A Group 1

Caution: This instrument is a Class A product, and it is designed for use in the industrial environment. Please use this instrument in the industrial environment only.

Note: Use the metal conduit for the remote cable.

Normal Operating Condition

Power Supply Voltage:

9 to 32 V DC for general-purpose, flameproof types and Nonincendive type

9 to 24 V DC for intrinsically safe type (Entity model)

9 to 17.5 V DC for intrinsically safe type (FISCO model)

Mass Flow Accuracy using Arithmetic (AR) function block:

(when outer temperature sensor and outer pressure sensor are used)

Accuracy +/- %: of Reading

Fluid	Mass Flow Accuracy	Notes		
		Input for Temperature, Pressure	Reference input condition for Mass Flow Accuracy	Flow computing
Saturated steam (Temperature base)	±1.7% (<35m/s) ±2.2% (35m/s–80m/s)	Temperature	Temperature range +100 to +330°C Temperature accuracy ±0.1%	Density computing by temperature using standard steam table (IAPWS-IF97: International Association for the Properties of Water and Steam)
Saturated steam (Pressure base)		Pressure	Pressure range 0.1MPa to Flange rating Pressure accuracy ±0.2%	Density computing by pressure using standard steam table (IAPWS-IF97: International Association for the Properties of Water and Steam)
Superheated steam		Temperature and Pressure	Pressure condition: Pressure range 0.1MPa to Flange rating Pressure accuracy ±0.2% Temperature condition: Temperature range +100 to + 450°C Temperature accuracy ±0.1%	Density computing by temperature and pressure using standard steam table (IAPWS-IF97: International Association for the Properties of Water and Steam)
General gas	Not fixed	Temperature and Pressure	Accuracy is changed by fluctuating Deviation factor K on Temperature, Pressure condition	Temperature, pressure compensation computing using gas equation (Boyle-Charles's) at fixed Deviation factor K.
Liquid	Not fixed	Temperature	Accuracy is changed by setting value for Temperature compensation factor	Density computing by temperature using equation API • JIS K2249.
General gas including Natural gas	For Natural gas ±1.1% (<35m/s) ±1.6% (35m/s–80m/s)	Temperature and Pressure	For Natural gas accuracy condition is Pressure condition: Pressure range 0 to 12MPa Pressure signal ±0.2% Temperature condition: Temperature range –10 to + 65°C Temperature signal ±0.1% General gas is computed using physical properties supported by DIPPR database (AIChE: American Institute of Chemical Engineers)	For natural gas, AGA No.8 is applied for temperature, pressure compensation computing For general gas and liquid, DIPPR database is applied (AIChE: American Institute of Chemical Engineers) for Mass flow computing. Density parameters are downloaded by FSA120 • FieldMate Flow Navigator.
Liquid	Not fixed	Temperature	Computed using physical properties supported by DIPPR database (AIChE: American Institute of Chemical Engineers)	

1) Mass Flow Accuracy for Steam and Natural gas is computed adding by Temperature and Pressure compensation based on Volumetric Flow Accuracy.

2) Mass Flow Accuracy for AI output is the same as Smart type (BRAIN, HARTprotocol). Refer to GS 01F06A00-01EN.

3) This temperature range differs to the equipment specification of digitalYEWFLOW.

T01-01.EPS

**Mass Flow or Volumetric Flow at Nominal/Standard condition Accuracy using Arithmetic (AR) function block:
(when Multi-variable type (MV) and outer pressure sensor are used)**

Accuracy +/- %: of Reading

Fluid	Mass Flow Accuracy	Notes		
		Input for Temperature, Pressure	Reference condition for Mass Flow Accuracy	Flow computing
Saturated steam (Temperature base)	±2.0% (<35m/s) ±2.5% (35m/s–80m/s)	Temperature	Temperature range +100 to +250°C	Density computing by temperature using standard steam table (IAPWS-IF97: International Association for the Properties of Water and Steam)
Saturated steam (Pressure base)		Pressure	Pressure range 0.1MPa to Flange rating Pressure accuracy ±0.2%	Density computing by pressure using standard steam table (IAPWS-IF97: International Association for the Properties of Water and Steam)
Superheated steam		Temperature and Pressure	Pressure condition: Pressure range 0.1MPa to Flange rating Pressure accuracy ±0.2% Temperature condition: Temperature range +100 to + 250°C	Density computing by temperature and pressure using standard steam table (IAPWS-IF97: International Association for the Properties of Water and Steam)
General gas	Not fixed	Temperature and Pressure	Accuracy is changed by fluctuating Deviation factor K on Temperature, Pressure condition	Temperature, pressure compensation computing using gas equation (Boyle-Charles's) at fixed Deviation factor K.
Liquid	Not fixed	Temperature	Accuracy is changed by setting value for Temperature compensation factor	Density computing by temperature using equation API • JIS K2249.
General gas including Natural gas	For Natural gas ±2.0% (<35m/s) ±2.5% (35m/s–80m/s)	Temperature and Pressure	For Natural gas accuracy condition is Pressure condition: Pressure range 0 to 12MPa Pressure signal ±0.2% Temperature condition: Temperature range –10 to + 65°C General gas is computed using physical properties supported by DIPPR database (AIChE: American Institute of Chemical Engineers)	For natural gas, AGA No.8 is applied for temperature, pressure compensation computing For general gas and liquid, DIPPR database is applied (AIChE: American Institute of Chemical Engineers) for Mass flow computing. Density parameters are downloaded by FSA120 • FieldMate Flow Navigator.
Liquid	Not fixed	Temperature	Computed using physical properties supported by DIPPR database (AIChE: American Institute of Chemical Engineers)	

1) Mass Flow Accuracy for Steam and Natural gas is computed adding by Temperature and Pressure compensation based on Volumetric Flow Accuracy.

2) Refer to GS 01F06A00-01EN about mass and volumetric flow accuracy of AI1 output and temperature accuracy of AI2 output.

T01-02.EPS

Electrical Specifications

Output Signals:

Digital communication signal compliant with the FOUNDATION Fieldbus protocol

Communication Requirement

Condition of Communication Line:

Supply voltage: 9 to 32 V DC

Supply current: 15 mA maximum

24 mA maximum for the software download

Functional Specifications:

Functional specifications for Fieldbus communication conform to the standard specifications (H1) of FOUNDATION fieldbus.

Function blocks

Block name	Number	Execution time	Note
AI	3	29 ms	AI1: Monitors the flow rate and totalized flow rate;, AI2: Monitors the temperature for a model with the multi-variable type option; AI3: Volumetric flow input for mass flow rate calculation of AR.
DI	2	25 ms	Flow and temperature limit switches
AR	1	40 ms	Mass flow calculation
IT	1	40 ms	Integrator block integrates a variable as a function of the time or accumulates the counts
PID	1	40 ms	Applicable when LC1 option is specified

T02.EPS

Link master function (BASIC of factory setting)

9.2 Optional Specifications

For options other than below, see GS 01F06A00-01EN.

(Note1) For intrinsically safe approval, use the barrier certified by the testing laboratories (BARD-400 is not applicable).

Item	Description	Code
PID Function	Provides a PID control function block.	LC1
Multi-variable Type	Provides a temperature sensor (Pt 1000) built into the vortex shedder bar, enabling the AI2 function block to output the process fluid temperature, and mass flow rates to be calculated. (For details, see GS 01F06A00-01EN.)	MV
Software download function	Based on FOUNDATION Fieldbus Specification (FF-883) Download class: Class 1	EE
Factory Mutual (FM)	FM explosion-proof Approval Applicable Standard: FM3600 1998, FM3611 1999, FM3615 1989, FM3810 1989, Including Supplement 1 1995, ANSI/NEMA 250 1991 Type of Protection: Explosion-proof for Class I, Division 1, Groups A, B, C, and D; Dust-ignitionproof Class II/III, Division 1, Groups E, F, and G. "SEAL ALL CONDUITS WITHIN 18 INCHES." "WHEN INSTALLED IN DIV.2, SEALS NOT REQUIRED." Enclosure Rating: NEMA TYPE 4X Temperature Code: T6 Ambient Temperature: -29 to +60°C (Integral Type Flowmeter and Remote Type Flowmeter) -40 to +60°C (Remote Type Converter) Maximum Working Pressure: 16 MPa (DY015 to DY200) 5 MPa (DY250 and DY300). Electrical Connection: ANSI 1/2 NPT female	FF1
	FM Intrinsically Safe Approval (Note 1) , Nonincendive Applicable Standard: FM3600 1998, FM3610 1999, FM3611 1999, FM3810 1989, IEC60079-27 2006, ANSI/NEMA 250 1991, ISA 60079-27 2006 Type of Protection : Intrinsically Safe for Class I, II, III, DIV.1, Groups A, B, C, D, E, F and G, T4, and Class I, Zone 0, AEx ia IIB/IIC T4, Entity, FISCO Nonincendive for Class I, II, Div.2, Groups A, B, C, D, F and G, Class III, DIV.1, Class I, Zone 2, Group IIC, FNICO Ambient Temperature : -29 to +60°C (Integral Type Flowmeter) -29 to +80°C (Remote Type Flowmeter) -40 to +60°C (Remote Type Converter) Indoors and Outdoors : NEMA TYPE 4X Electrical Parameters : Intrinsically Safe [Entity] Vmax=24V, Imax=250mA, Pi=1.2W, Ci=1.76nF, Li=0 [FISCO (IIC)] Vmax=17.5V, Imax=380mA, Pi=5.32W, Ci=1.76nF [FISCO (IIB)] Vmax=17.5V, Imax=460mA, Pi=5.32W, Ci=1.76nF, Li=0 Nonincendive Vmax=32V, Ci=1.76nF, Li=0 Electrical Connection : ANSI 1/2NPT female	FS16

T03-01.EPS

9. GENERAL SPECIFICATIONS

Item	Description	Code
CENELEC ATEX (KEMA)	<p>CENELEC ATEX(KEMA) explosion-proof Approval Applicable Standard: EN50014: 1997, EN50018: 2000, EN60529: 1991, EN61010-1: 1993 Type of Protection: EExd IIC T6...T1 (Integral Type Flowmeter and Remote Type Flowmeter) EExd IIC T6 (Remote Type Converter)</p> <p>Group: II Category: 2G Process Temp. : T6; 85°C, T5; 100°C, T4; 135°C, T3; 200°C, T2 (*); 300°C, T1 (*); 450°C (*: Use /HT version above 250°C) Degree of Protection of Enclosure: IP67 Tamb: -29 to +60°C (Integral Type Flowmeter and Remote Type Flowmeter) : -40 to +60°C (Remote Type Converter) : -30 to +60°C (Remote Type Converter with indicator) Maximum Working Pressure: 15 MPa (DY015 to DY200) 5 MPa (DY250 and DY300)</p> <p>Electrical Connection: ANSI 1/2 NPT female, ISO M20 × 1.5 female</p>	KF1
	<p>CENELEC ATEX(KEMA) Intrinsically Safe Approval (Note 1) Applicable Standard : EN50014: 1997, EN50020: 2002, EN50284: 1999, EN60529: 1991 Type of Protection: EEx ia IIB/IIC T4...T1 (Integral Type Flowmeter and Remote Type Flowmeter) EEx ia IIB/IIC T4 (Remote Type Converter)</p> <p>Group: II Category: 1G Maximum Working Pressure: 15MPa (DY015 to DY200) 5MPa (DY250 and DY300) Tamb: -29 to +60°C (Integral Type Flowmeter) : -29 to +80°C (Remote Type Flowmeter) : -40 to +60°C (Remote Type Converter) Process Temp. : T4; 135°C, T3; 200°C, T2; 300°C, T1;450°C (Use /HT version above 250°C) For connection to certified Intrinsically Safe circuit with Supply circuit of Integral Type Flowmeter and Remote Type Converter: [Entity] Vmax=24V, Imax=250mA, Pi=1.2W, Ci=1.76nF, Li=0 [FISCO (IIC)] Vmax=17.5V, Imax=380mA, Pi=5.32W, Ci=1.76nF [FISCO (IIB)] Vmax=17.5V, Imax=460mA, Pi=5.32W, Ci=1.76nF, Li=0 Connect sensor circuit of DYA and DY-N</p> <p>Electrical Connection: ANSI 1/2NPT female, ISO M20 × 1.5 female</p>	KS26
CENELEC ATEX	<p>CENELEC ATEX Type n Approval Applicable Standards: EN 60079-15 :2005, IEC 60079-0 :2004, IEC 60079-11 :1999, EN 60529 :1991 Type of protection: EX nL IIC T4...T1 (Integral Type Flowmeter and Remote Type Flowmeter) EX nL IIC T4 (Remote Type Converter)</p> <p>Group: II Category: 3G Maximum Working Pressure: 15MPa (DY015 to DY200) 5MPa (DY250 and DY300) Ambient Temperature: -29 to 60°C (-29 to 140° F)(Integral Type Flowmeter) -29 to 80°C (-29 to 176° F)(Remote Type Flowmeter) -40 to 60°C (-40 to 140° F)(Remote Type Converter) Process Temperature: T4; 135°C, T3; 200°C, T2 (*); 300°C, T1 (*); 450°C (*: Use /HT version above 250°C) Degree of Protection of Enclosure: IP67 Maximum Capacitance of Cable: 160nF</p> <p>Electrical Connection : ANSI 1/2NPT female, ISO M20 × 1.5 female</p>	KN25
Canadian Standards Association (CSA)	<p>CSA Explosion-proof Approval Applicable Standard: C22.1-98, C22.2 No.0, C22.2 No.0.4, C22.2 No.0.5, C22.2 No.25, C22.2 No.30, C22.2 No.94, C22.2 No.142, C22.2, No.61010-1, ANSI/ISA-12.27.01 Type of Protection: explosion-proof for Class I, Groups B, C and D; Class II, Groups E, F and G; Class III. For Class I, Division 2 location: "FACTORY SEALED, CONDUIT SEAL NOT REQUIRED." Enclosure: Type 4X Temperature Code: T6...T1(Integral Type Flowmeter and Remote Type Flowmeter) T6 (Remote Type Converter) Amb. Temp.: -29 to +60°C (Integral Type Flowmeter and Remote Type Flowmeter) -40 to +60°C (Remote Type Converter) Process Temp. : T6;85°C, T5;100°C, T4;135°C, T3;200°C, T2;300°C, T1;450°C Maximum Working Pressure: 15 MPa (DY015 to DY200) 5 MPa (DY250 and DY300)</p> <p>Electrical Connection: ANSI 1/2 female</p>	CF1
	<p>CSA Explosion-proof Approval • The approval specification is the same with /CF1. • Process Sealing Certification Dual Seal Certified by CSA to the requirement of ANSI/ISA 12.27.01 No additional sealing required</p>	CF11
Standard Association of Australia (SAA)	<p>SAA Flame Proof Approval Applicable Standard: AS 2380.1-1989, AS2380.2-1991, AS1939-1990 Type of protection: Ex d IIC T6...T1, IP67 Amb.Temp.: -29 to +60°C (Integral Type Flowmeter and Remote Type Flowmeter) -40 to +60°C (Remote Type Converter) Max. process temp. : T6;85°C, T5;100°C, T4;135°C, T3;200°C, T2;300°C, T1;450°C</p> <p>Electrical connection: ANSI 1/2 NPT female, ISO M20 × 1.5 female</p>	SF1
Technology Institution of Industrial Safety (TIIS), Japan	<p>TIIS explosion-proof ExdIIC T6 approval Amb. temp. : -20 to 60°C (integral type flowmeter and remote type flowmeter) Electrical connection: JIS G1/2 female</p>	JF3

T03-02.EPS

Setting When Shipped.

Item	AI1 for Flow Rate Signal (Standard)	AI2 for Temperature Signal (with MV Option)
Tag number* (PD_TAG)	Set to "FT1003" by default unless otherwise specified when ordered.	
Output mode (L_TYPE)	"Direct"	
Upper and lower calculation range limits and unit (XD_SCALE)	The upper range limit will be set to the maximum flow rate range specified in the registered sizing data, or to the 0 to 10 m ³ /h range in case of UNCALIBRATION.	-40 to 260°C or -40 to 500°F
Upper and lower output range limits and unit (OUT_SCALE)		
Node address	Set to 0xF2 unless otherwise specified when ordered.	

T04.EPS

Explanation of parameters:

- (1) XD_SCALE: Defines the input values from the transducer block (input range of the sensor) corresponding to 0% and 100% values in the calculation inside the AI function block. For a digital YEW FLO, the values set as the flow span or temperature range (optional) are stored in this parameter.
- (2) OUT_SCALE: Output scaling parameter. Defines the output values corresponding to 0% and 100% values in the calculation inside the AI function block.
- (3) L_TYPE: Determines whether the values passed from the transducer block (sensor) should be output without processing ("Direct") or through scaling conversion based on OUT_SCALE ("Indirect").

10. EXPLOSION PROTECTED TYPE INSTRUMENT

In this section, further requirements and differences for explosion proof type instrument are described except JIS Flame proof. For explosion proof type instrument, the description in this chapter is prior to other description in this Instruction Manual.



WARNING

- Only trained persons use this instrument in industrial locations.

10.1 CENELEC ATEX (KEMA)



WARNING

- Only trained persons use this instrument in industrial locations.

10.1.1 Technical Data

• Explosion proof

Applicable Standard : EN50014: 1997, EN50018: 2000

Certificate : KEMA 01ATEX2072

Type of protection: EEx d IIC T6...T1 (Integral Type Flowmeter and Remote Type Flowmeter)
EEx d IIC T6 (Remote Type Converter)

Group: II

Category: 2G

Temperature Class: (Integral Type Flowmeter and Remote Type Flowmeter)

Temperature Class	Ambient Temperature	Process Temperature
T6	60°C	≦85°C
T5	60°C	≦100°C
T4	60°C	≦135°C
T3	60°C	≦200°C
T2 *1	60°C	≦300°C
T1 *1	60°C	≦450°C

T100101-1.eps

*1 Note: Use /HT version above 250°C

Temperature Class: T6 (Remote Type Converter)

Enclosure: IP67

Tamb: -29 to +60°C (Integral Type Flowmeter and Remote Type Flowmeter)

-40 to +60°C (Remote Type Converter)

-30 to +60°C (Remote Type Converter with indicator)

Power Supply: 10.5 to 42Vdc max.

Output Signal: Current Output; 4 to 20mAcd

Pulse output; On=2Vdc, 200mA

Off=42Vdc, 4mA

Maximum Working Pressure: 16MPa(DY015 to DY200)

5MPa(DY200 and DY300)

Electrical Connection: ANSI 1/2 NPT female,
ISO M20 X 1.5 female

• Intrinsically Safe

Applicable Standard: EN50014: 1997, EN50020: 2002

EN50284: 1999, EN60529: 1991

Certificate: KEMA 03ATEX1136X

Type of Protection: EEx ia IIB/IIC T4...T1 (Integral Type Flowmeter and Remote Type Flowmeter)
EEx ia IIB/IIC T4 (Remote Type Converter)

Group: II

Category: 1G

Maximum Working Pressure: 16MPa (DY015 to DY200)

5MPa (DY250 and DY300)

Tamb: -29 to +60°C (Integral Type Flowmeter)

-29 to +80°C (Remote Type Flowmeter)

-40 to +60°C (Remote Type Converter)

(Integral Type Flowmeter)

Temperature Class	Ambient Temperature	Process Temperature
T4	60°C	≦135°C
T3	60°C	≦200°C
T2*	60°C	≦300°C
T1*	60°C	≦450°C

T100101-2.eps

*: Use /HT version above 250°C

(Remote Type Flowmeter)

Temperature Class	Ambient Temperature	Process Temperature
T4	80°C	≦135°C
T3	80°C	≦200°C
T2*	80°C	≦300°C
T1*	80°C	≦450°C

T100101-3.eps

*: Use /HT version above 250°C

Electrical data:

Supply and Output Circuit (SUPPLY + and -, PULSE + and -);

Maximum Input Voltage $U_i = 30 \text{ V}$

Maximum Input Current $I_i = 165 \text{ mA}$

Maximum Input Power $P_i = 0.9 \text{ W}$

Internal Capacitance $C_i = 6 \text{ nF}$

Internal Inductance $L_i = 0.15 \text{ mH}$

For the connection of DYA to DY-N :

Maximum cable capacitance: 160nF

Electrical Connection: ANSI 1/2 NPT female, ISO M20 X 1.5 female

Special conditions for safe use

1. For process temperatures above 260°C the flow meters of the DY/HT or DY-N/HT series must be used.
2. Because the enclosures of the flow meters and the flow converter are made of aluminium alloy, when used in a potentially explosive atmosphere requiring apparatus of equipment category 1 G, they must be installed so, that even in the event of rare incidents, an ignition source due to impact of friction between the enclosure and iron/steel is excluded.

• Type of Protection “n”

Applicable Standard: EN60079-15: 2005, IEC60079-0: 2004,
IEC60079-11: 1999, EN60529: 1991

Type of protection: Ex nL IIC T4...T1 (Integral Type
Flowmeter and Remote Type Flowmeter)
EEx nL IIC T4 (Remote Type Converter)

Group: II

Category: 3G

Maximum Working Pressure: 16MPa (DY015 to DY200)
5MPa (DY250 and DY300)

Degree of protection of enclosure: IP67

Tamb. : -29 to +60°C (Integral Type Flowmeter)

-29 to +80°C (Remote Type Flowmeter)

-40 to +60°C (Remote Type Converter)

(Integral Type Flowmeter)

Temperature Class	Ambient Temperature	Process Temperature
T4	60°C	≦135°C
T3	60°C	≦200°C
T2*	60°C	≦300°C
T1*	60°C	≦450°C

T100101-4.eps

*: Use /HT version above 250°C

(Remote Type Flowmeter)

Temperature Class	Ambient Temperature	Process Temperature
T4	80°C	≦135°C
T3	80°C	≦200°C
T2*	80°C	≦300°C
T1*	80°C	≦450°C

T100101-5.eps

*: Use /HT version above 250°C

Electrical data

Signal/Supply and Pulse circuit

Ui= 32Vdc (30Vdc for the remote converter),

Ci= 1.76nF, Li= 0mH

For connection of DY-N series

Maximum capacitance of cable: 160nF

Connect to DYA series only

Electrical Connection: ANSI 1/2 NPT female, ISO M20 X 1.5
female

10.1.2 Installation**WARNING**

- All wiring shall comply with local installation requirements and local electrical code.
- Use the suitable heat-resisting cables (over 90°C) for the digital YEW FLO Model DY Series Vortex Flowmeter when the ambient temperature exceeds +70°C and/or the process temperature exceeds 135°C.
- The cable entry devices shall be certified in type of protection flame proof enclosure “d” and suitable for the conditions of use and correctly installed.
- Unused apertures shall be closed with certified blanking elements in type of protection flame proof enclosure “d”.

10.1.3 Operation**WARNING**

- Wait 10 min. after power is turned off, before opening the covers.
- Take care not to generate mechanical spark when access to the instrument and peripheral devices in hazardous locations.

10.1.4 Maintenance and Repair**WARNING**

- The instrument modification or parts replacement by other than authorized representative of Yokogawa Electric Corporation is prohibited and will void the certification.

10.1.5 Installation Diagram of Intrinsically safe (and Note)

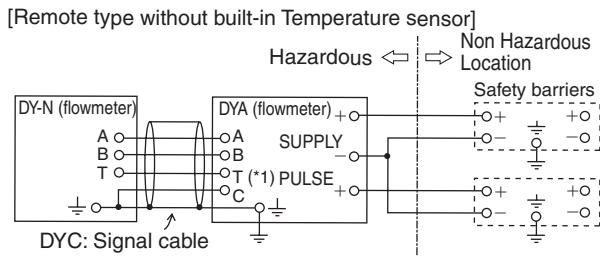
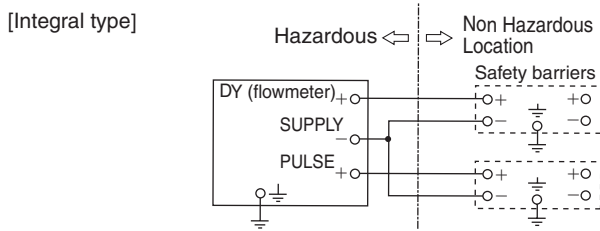

Note: In any safety barrier used output current must be limited by a resistor 'R' such that $I_o=U_o/R$

Electric data:
 Supply and Output Circuit (SUPPLY + and -, PULSE+ and -)
 Maximum Input Voltage U_i : 30V
 Maximum Input Current I_i : 165mA
 Maximum Input Power P_i : 0.9W
 Internal Capacitance C_i : 6nF
 Internal Inductance L_i : 0.15mH

F100101.EPS

10.1.6 Installation Diagram of Type of Protection "n"

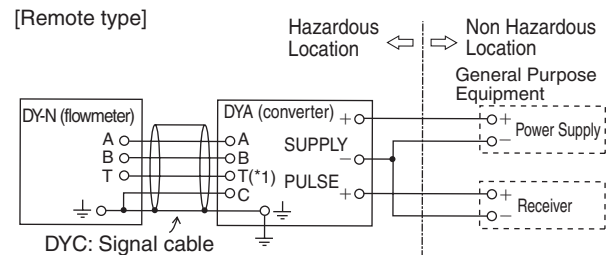
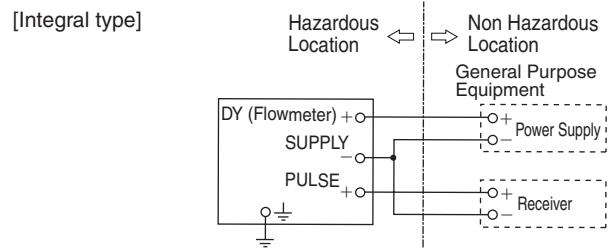

(*1): Wire for T terminal
 With temperature sensor type: Installed
 Without temperature sensor type: Not Installed

Electric data:
 Maximum Input Voltage U_i : 30V
 Internal Capacitance C_i : 6nF
 Internal Inductance L_i : 0.15mH

F100101-1.EPS

IMPORTANT

- In hazardous location, BT200 BRAIN Terminal can not be connected to the digital YEWFLOW which is approved by CENELEC (KEMA) Intrinsically Safe. (See the IM 1C0A11-01E).

10.1.7 Screw Marking

The type of electrical connection is stamped near the electrical connection port according to the following codes.

SCREW SIZE	MARKING
M20 X 1.5	⚠ M
1/2-14NPT	⚠ A

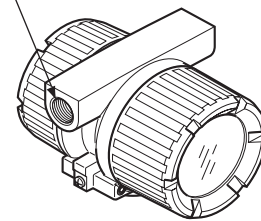

F100103.EPS

10.1.8 Name Plate

[Integral type, Flameproof]

digital YEW FLO VORTEX FLOWMETER		OUTPUT	MWP	MPa at 38°C	TAG NO.
MODEL	STYLE	K-FACTOR			 No. KEMA 03ATEX2072 Ex II IC T4-T1 IP67 Tamb: -20 TO +80°C ENCLOSURE: IP67 TEMP CLASS: T6 T5 T4 T3 T2 T1 PROCESS TEMP: 150 200 300 450°C NOTE: USE /HT VERSION ABOVE 250°C
SUFFIX		RANGE			
		NO.			
SUPPLY		V DC	WARNING THE PROCESS TEMP ≥ 200°C USE THE HEAT-RESISTING CABLE OF HIGHER THAN 90°C AFTER DE-ENERGIZING, DELAY 3 MINUTES BEFORE OPENING. THE ENCLOSURE IS HOT AT HIGH PROCESS TEMP.		
YOKOGAWA		Made in China TOKYO 180-8750 JAPAN			N200 UE

[Remote type detector, Flameproof]

digital YEW FLO VORTEX FLOWMETER		MWP	MPa at 38°C	TAG NO.	
MODEL	STYLE	K-FACTOR		 No. KEMA 03ATEX2072 Ex II IC T4-T1 IP67 Tamb: -20 TO +80°C ENCLOSURE: IP67 TEMP CLASS: T6 T5 T4 T3 T2 T1 PROCESS TEMP: 150 200 300 450°C NOTE: USE /HT VERSION ABOVE 250°C	
SUFFIX		RANGE			
		NO.			
SUPPLY		V DC	WARNING THE PROCESS TEMP ≥ 200°C USE THE HEAT-RESISTING CABLE OF HIGHER THAN 90°C AFTER DE-ENERGIZING, DELAY 3 MINUTES BEFORE OPENING. THE ENCLOSURE IS HOT AT HIGH PROCESS TEMP.		
YOKOGAWA		Made in China TOKYO 180-8750 JAPAN			N200 WE

[Remote type converter, Flameproof]

digital YEW FLO VORTEX FLOW CONVERTER		OUTPUT		TAG NO.	
MODEL	STYLE	K-FACTOR		 No. KEMA 03ATEX2072 Ex II IC T4-T1 IP67 Tamb: -20 TO +80°C ENCLOSURE: IP67 TEMP CLASS: T6 T5 T4 T3 T2 T1 PROCESS TEMP: 150 200 300 450°C NOTE: USE /HT VERSION ABOVE 250°C	
SUFFIX		RANGE			
		NO.			
SUPPLY		V DC	WARNING THE PROCESS TEMP ≥ 200°C USE THE HEAT-RESISTING CABLE OF HIGHER THAN 90°C AFTER DE-ENERGIZING, DELAY 3 MINUTES BEFORE OPENING.		
YOKOGAWA		Made in China TOKYO 180-8750 JAPAN			N200 YE

[Integral type, Intrinsically safe]

digital YEW FLO VORTEX FLOWMETER		OUTPUT	---	TAG NO.	
MODEL	STYLE	K-FACTOR		 No. KEMA 03ATEX1159 X Ex II IC T4-T1 IP67 Tamb: -20 TO +80°C Ex II IB T4-T1 IP67 Tamb: -20 TO +80°C FISCO FIELD DEVICE SEE CERTIFICATE FOR DATA NOTE: USE /HT VERSION ABOVE 250°C	
SUFFIX		RANGE			
		NO.			
SUPPLY		9~17.5(24) V DC	WARNING THE PROCESS TEMP ≥ 200°C USE THE HEAT-RESISTING CABLE OF HIGHER THAN 90°C THE ENCLOSURE IS HOT AT HIGH PROCESS TEMP. REFER TO USER'S MANUAL FOR SUPPLY.		
YOKOGAWA		Made in China TOKYO 180-8750 JAPAN			N200 UT

[Integral type detector, Intrinsically safe]

digital YEW FLO VORTEX FLOWMETER		MWP	MPa at 38°C	TAG NO.	
MODEL	STYLE	K-FACTOR		 No. KEMA 03ATEX1159 X Ex II IC T4-T1 IP67 Tamb: -20 TO +80°C Ex II IB T4-T1 IP67 Tamb: -20 TO +80°C CONNECT TO DIA SERIES ONLY SEE CERTIFICATE FOR DATA NOTE: USE /HT VERSION ABOVE 250°C	
SUFFIX		RANGE			
		NO.			
SUPPLY		V DC	WARNING THE PROCESS TEMP ≥ 200°C USE THE HEAT-RESISTING CABLE OF HIGHER THAN 90°C THE ENCLOSURE IS HOT AT HIGH PROCESS TEMP.		
YOKOGAWA		Made in China TOKYO 180-8750 JAPAN			N200 WT

[Integral type converter, Flameproof]

digital YEW FLO VORTEX FLOW CONVERTER		OUTPUT	---	TAG NO.	
MODEL	STYLE	K-FACTOR		 No. KEMA 03ATEX1159 X Ex II IC T4-T1 IP67 Tamb: -20 TO +80°C Ex II IB T4-T1 IP67 Tamb: -20 TO +80°C FISCO FIELD DEVICE SEE CERTIFICATE FOR DATA	
SUFFIX		RANGE			
		NO.			
SUPPLY		9~17.5(24) V DC	REFERENCE TO USER'S MANUAL.		
YOKOGAWA		Made in China TOKYO 180-8750 JAPAN			N200 YT

[Integral type, Type n protection]

digital YEW FLO VORTEX FLOWMETER		OUTPUT	---	TAG NO.	
MODEL	STYLE	K-FACTOR		 Ex II IC T4-T1 IP67 Tamb: -20 TO +80°C ENCLOSURE: IP67 TEMP CLASS: T4 T3 T2 T1 PROCESS TEMP: 150 200 300 450°C (I = 32V, CI = 1.76mH, LI = 0mH) NOTE: USE /HT VERSION ABOVE 250°C	
SUFFIX		RANGE			
		NO.			
SUPPLY		9~32V DC	WARNING THE PROCESS TEMP ≥ 200°C USE THE HEAT-RESISTING CABLE OF HIGHER THAN 90°C THE ENCLOSURE IS HOT AT HIGH PROCESS TEMP.		
YOKOGAWA		Made in China TOKYO 180-8750 JAPAN			N200 UV

[Remote type detector, Type n protection]

digital YEW FLO VORTEX FLOWMETER		MWP	MPa at 38°C	TAG NO.	
MODEL	STYLE	K-FACTOR		 Ex II IC T4-T1 IP67 Tamb: -20 TO +80°C ENCLOSURE: IP67 TEMP CLASS: T4 T3 T2 T1 PROCESS TEMP: 150 200 300 450°C NOTE: USE /HT VERSION ABOVE 250°C	
SUFFIX		RANGE			
		NO.			
SUPPLY		V DC	WARNING THE PROCESS TEMP ≥ 200°C USE THE HEAT-RESISTING CABLE OF HIGHER THAN 90°C THE ENCLOSURE IS HOT AT HIGH PROCESS TEMP.		
YOKOGAWA		Made in China TOKYO 180-8750 JAPAN			N200 WV

[Remote type converter, Type n protection]

digital YEW FLO VORTEX FLOW CONVERTER		OUTPUT	---	TAG NO.	
MODEL	STYLE	K-FACTOR		 Ex II IC T4-T1 IP67 Tamb: -20 TO +80°C ENCLOSURE: IP67 UI = 32V, CI = 1.76mH, LI = 0mH	
SUFFIX		RANGE			
		NO.			
SUPPLY		9~32V DC	WARNING THE PROCESS TEMP ≥ 200°C USE THE HEAT-RESISTING CABLE OF HIGHER THAN 90°C THE ENCLOSURE IS HOT AT HIGH PROCESS TEMP.		
YOKOGAWA		Made in China TOKYO 180-8750 JAPAN			N200 YV

MODEL: Specified model code

SUFFIX : Specified suffix code

STYLE: Style code

SUPPLY : Supply voltage

OUTPUT : Output signal

MWP : Maximum working pressure

K-FACTOR : Device-specific factor

RANGE: Specified range

NO.: Manufacturing serial number *1

*1) The first digit in the final three numbers of the serial number appearing after "NO." on the nameplate indicates the year of production. The following is an example of a serial number for a product that was produced in 2011:

NO. S5K965926 135

↑Produced in 2011

TAG NO. : Specified TAG No.

CE: CE marking

0344: The identification number of the notified body.

II2G: Group II Category 2 Gas atmosphere

II1G: Group II Category 1 Gas atmosphere

II3G: Group II Category 3 Gas atmosphere

10.2 FM

10.2.1 Technical Data

• Explosion Proof

Applicable Standard: FM3660 1998, FM3611 1999,
FM3615 1989, FM3810 1989,
Including Supplement 1 1995,
ANSI/NEMA 250 1991

Type of Protection: Explosion proof for Class I, Division 1,
Groups A,B, C and D;
Dust-ignition proof for Class II/III,
Division 1, Groups E, F,and G.

"SEAL ALL CONDUITS 18 INCHES." " WHEN
INSTALLED IN DIV.2, SEALS NOT REQUIRED"

Enclosure Rating: NEMA Type 4X

Temperature Code: T6

Ambient Temperature: -29 to 60°C (Integral Type Flowmeter
and Remote Type Flowmeter)
-40 to 60°C (Remote Type Converter)

Power Supply: 42Vdc max. (Integral Type Flowmeter and
Remote Type Converter)

Output Signal (Integral Type Flowmeter):

Current Output; 4 to 20mA

Pulse Output; On=2Vdc, 200mA

Off=42Vdc, 4mA

Output Signal (Remote Type Flowmeter):

Output Signal to Converter; 30Vp-p, 100µAp-p

Input/Output Signal (Remote Type Converter):

Current Output; 4 to 20mA

Pulse Output; On=2Vdc, 200mA

Off=42Vdc, 4mA

Input Signal from Flowmeter; 30Vp-p, 100µAp-p

Maximum Working Pressure: 15MPa (DY015 to DY200)

5MPa (DY250 and DY300)

Electrical connection : ANSI 1/2 NPT female (Special)

• Intrinsically Safe

Applicable Standard: FM3600: 1998, FM3610: 1999,
FM3611: 1999, FM3810: 1989,
IEC60079-27: 2006,
ANSI/NEMA 250 1991,
ISA 60079-27 2006

Type of Protection : Intrinsically Safe for Class I, II, III,
DIV.1, Groups A, B, C, D, E, F and G, T4, and Class
I, Zone 0, AEx ia IIB/IIC T4, Entity, FISCO
Nonincendive for Class I, II, Div.2, Groups A, B, C,
D, F and G, Class III, DIV.1, Class I, Zone 2, Group
IIC, FNICO

Ambient Temperature :

-29 to +60°C (Integral Type Flowmeter)

-29 to +80°C (Remote Type Flowmeter)

-40 to +60°C (Remote Type Converter)

Indoors and Outdoors : NEMA Type 4X

Electrical Parameters : Intrinsically Safe

[Entity] Vmax=24V, Imax=250mA, Pi=1.2W,

Ci=1.76nF, Li=0

[FISCO (IIC)] Vmax=17.5V, Imax=380mA,

Pi=5.32W, Ci=1.76nF

[FISCO (IIB)] Vmax=17.5V, Imax=460mA,

Pi=5.32W, Ci=1.76nF, Li=0

Nonincendive

Vmax=32V, Ci=1.76nF, Li=0

10.2.2 Wiring

• Explosion proof



WARNING

- All wiring shall comply with National Electrical Code ANSI/NFPA 70 and Local Electrical Code.
- "SEAL ALL CONDUITS 18 INCHES" " WHEN INSTALLED DIV.2, SEALS NOT REQUIRED".

• Intrinsically Safe



NOTE

- The FM Approved Hand Held Communicator may be connected at any point in the loop between the digital YEW FLO and the Control Equipment.

10.2.3 Operation

• Explosion proof



WARNING

- Note a warning label worded as follows.
Warning: OPEN CIRCUIT BEFORE REMOVING COVER.
INSTALL IN ACCORDANCE WITH THE INSTRUCTION MANUAL (IM) IF6A1-01E.
- Take care not to generate mechanical spark when access to the instrument and peripheral devices in hazardous locations.

10.2.4 Maintenance and Repair



WARNING

- The instrument modification or part replacements by other than authorized representative of Yokogawa Electric Corporation is prohibited and will void the approval of FM Approvals.

10.2.5 Installation Diagram

Intrinsically Safe (and WARNING)

[Integral type]

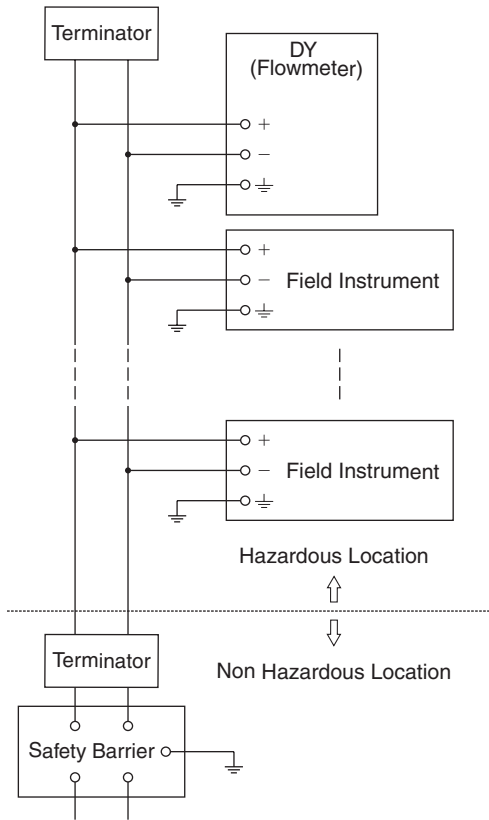

[Remote type]

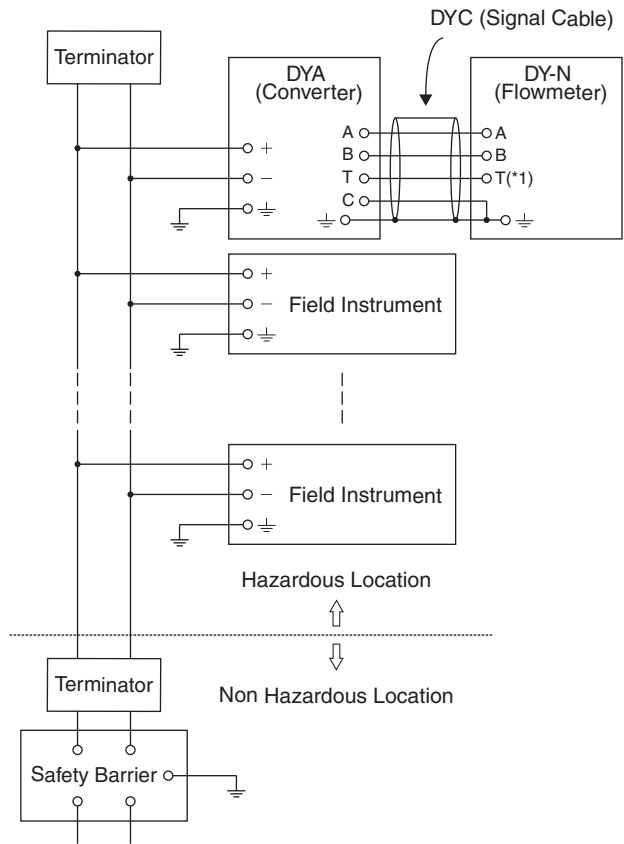

(*1) Wire for T terminal
 With Temperature sensor type : installed
 Without Temperature sensor type : not installed

F100201_1.EPS

• FISCO rules

The FISCO Concept allows the interconnection of intrinsically safe apparatus to Safety Barrier not specifically examined in such combination. The criterion for such interconnection is that the voltage (V_{max}), the current (I_{max}) and the power (P_i) which intrinsically safe apparatus can receive and remain intrinsically safe, considering faults, must be equal or greater than the voltage (U_o , V_o , V_t), the current (I_o , I_{sc} , I_t) and the power (P_o) which can be provided by the Safety Barrier (supply unit). In addition, the maximum unprotected residual capacitance (C_i) and inductance (L_i) of each apparatus (other than the terminators) connected to the Fieldbus must be less than or equal to 5nF and 10 μ H respectively.

In each I.S. Fieldbus segment only one active source, normally the Safety Barrier, is allowed to provide the necessary power for the Fieldbus system. The allowed voltage (U_o , V_o , V_t) of the Safety Barrier used to supply the bus must be limited to the range of 14V d.c. to 24V d.c. All other equipment connected to the bus cable has to be passive, meaning that the apparatus is not allowed to provide energy to the system, except to a leakage current of 50 μ A for each connected device. Separately powered equipment needs a galvanic isolation to insure that the intrinsically safe Fieldbus circuit remains passive.

The cable used to interconnect the devices needs to comply with the following parameters:

Loop resistance R': 15 ... 150 Ω /KM

Inductance per unit length L': 0.4 ... 1mH/km

Capacitance per unit length C': 80 ... 200 nF/km

$C' = C'$ line/line + 0.5 C' line/screen, if both lines are floating

or

$C' = C'$ line/line + C' line/screen, if the screen is connected to one line

Length of spur Cable: max. 30m

Length of trunk cable: max. 1Km

Length of splice: max. 1m

Terminators

At each end of the trunk cable an approved line terminator with the following parameters is suitable:

$R = 90 \dots 100\Omega$

$C = 0 \dots 2.2 \mu$ F.

System evaluation

The number of passive devices like transmitters, actuators, connected to a single bus segment is not limited due to I.S. reasons. Furthermore, if the above rules are respected, the inductance and capacitance of the cable need not to be considered and will not impair the intrinsic safety of the installation.

Installation Notes For FISCO and Entity Concepts:

1. The Intrinsic Safety Entity concept allows the interconnection of FM Approved Intrinsically safe devices with entity parameters not specifically examined in combination as a system when:
 U_o or V_o or $V_t \leq V_{max}$, I_o or I_{sc} or $I_t \leq I_{max}$, $P_o \leq P_i$. C_a or $C_o \geq \sum C_i + \sum C_{cable}$, For inductance use either L_a or $L_o \geq \sum L_i + \sum L_{cable}$ or $L_c/R_c \leq (L_a/R_a$ or $L_o/R_o)$ and $L_i/R_i \leq (L_a/R_a$ or $L_o/R_o)$
2. The Intrinsic Safety FISCO concept allows the interconnection of FM Approved Intrinsically safe devices with FISCO parameters not specifically examined in combination as a system when:
 U_o or V_o or $V_t \leq V_{max}$, I_o or I_{sc} or $I_t \leq I_{max}$, $P_o \leq P_i$.
3. The Safety Barrier shall be a linear supply for Entity installations and either a linear supply or a trapezoidal supply for FISCO Installations.
4. Dust-tight conduit seals must be used when installed in Class II and Class III environments.
5. Control equipment connected to the Safety Barrier must not use or generate more than 250 Vrms or Vdc.
6. Installation should be in accordance with ANSI/ISA RP12.06.01 (except chapter 5 for FISCO Installations) "Installation of Intrinsically Safe Systems for Hazardous (Classified) Locations" and the National Electrical Code® (ANSI/NFPA 70) Sections 504 and 505.
7. The configuration of Safety Barrier must be FM Approved under the associated concept.
8. Safety Barrier manufacturer's installation drawing must be followed when installing this equipment.
9. The (Product Name) Series are Approved for Class I, Zone 0, applications. If connecting AEx[ib] Safety Barrier or AEx ib I.S. Apparatus to the (Product Name) Series the I.S. circuit is only suitable for Class I, Zone 1, or Class I, Zone 2, and is not suitable for Class I, Zone 0 or Class I, Division 1, Hazardous (Classified) Locations."
10. No revision to drawing without prior FM Approval.

10. EXPLOSION PROTECTED TYPE INSTRUMENT

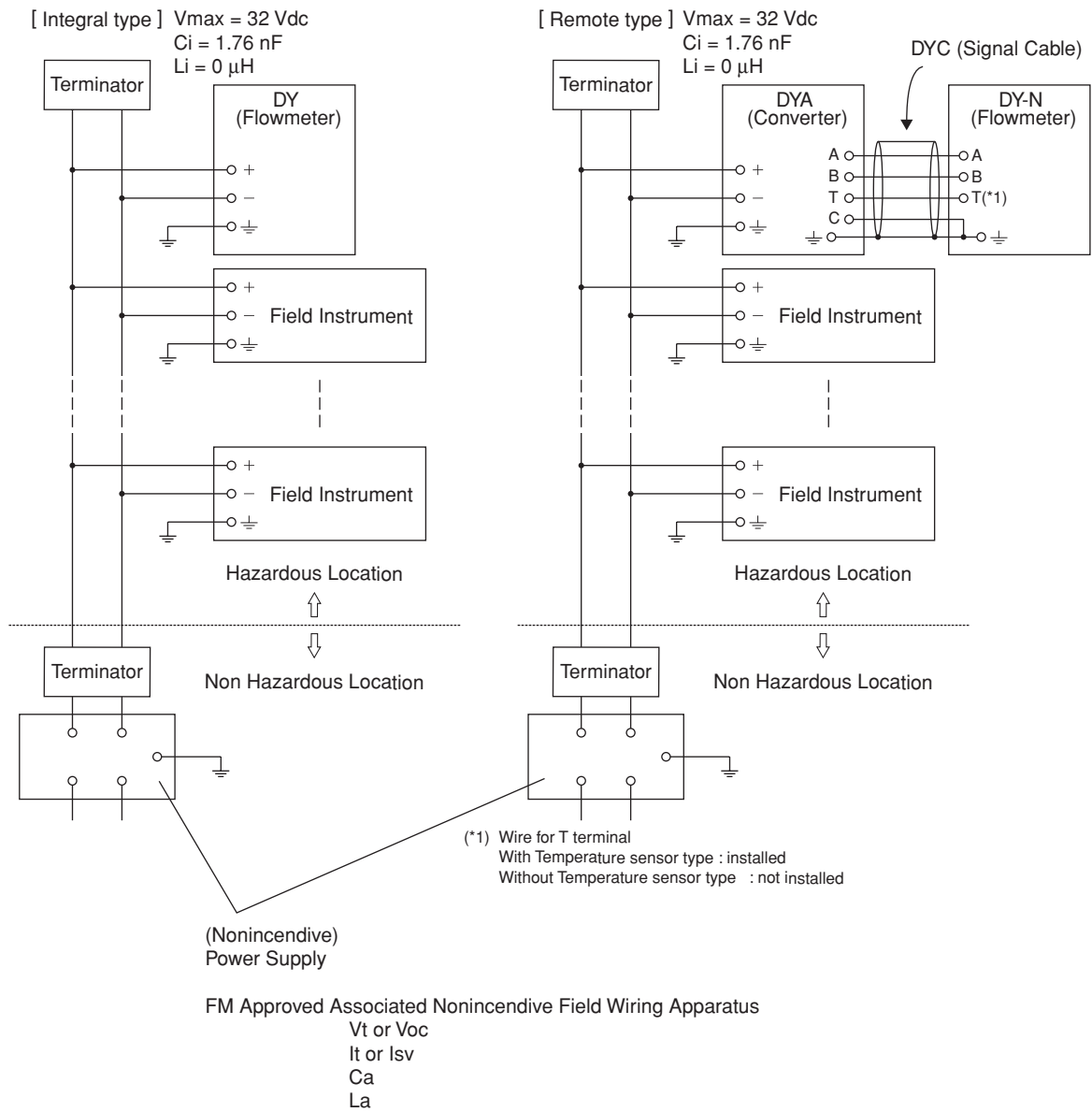

F100201_2.EPS

**NOTE**

1. Dust-tight conduit seal must be used when installed in Class II and Class III environments.
2. Installation should be in accordance with the National Electrical Code® (ANSI/NFPA 70) Sections 504 and 505.
3. The configuration of Associated Nonincendive Field Wiring Apparatus must be FM Approved.
4. Associated Nonincendive Field Wiring Apparatus manufacturer's installation drawing must be followed when installing this equipment.
5. No revision to drawing without prior FM Approvals.
6. Terminator and supply unit must be FM Approved.
7. If use ordinary wirings, the general purpose equipment must have nonincendive field wiring terminal approved by FM Approvals.
8. The nonincendive field wiring circuit concept allows interconnection of nonincendive field wiring apparatus with associated nonincendive field wiring apparatus, using any of the wiring methods permitted for unclassified locations.
9. Installation requirements;
 $V_{max} \geq V_{oc}$ or V_t
 I_{max} = see note 10.
 $C_a \geq C_i + C_{cable}$
 $L_a \geq L_i + L_{cable}$
10. For this current controlled circuit, the parameter (I_{max}) is not required and need not be aligned with parameter (I_{sc} or I_t) of the barrier or associated nonincendive field wiring apparatus.
11. Approved under FNICO Concept.

Electrical data:

$$V_{max} = 32V$$

$$C_i = 1.76nF$$

$$L_i = 0$$

10.3 SAA



WARNING

Only trained persons use this instrument in industrial locations.

10.3.1 Technical Data

• Flameproof

Applicable Standard: AS 2380.1-1989, AS2380.2-1991,
AS1939-1990
Certificate: AUS Ex 3808X
Type of Protection: Exd IIC T6....T1, IP67
Ambient Temperature : -29 to +60°C
(Integral type flowmeter and
Remote type flowmeter)
-40 to +60°C
(Remote type converter)
Max. Process Temp : T6; 85°C, T5; 100°C,
T4: 135°C, T3; 200°C,
T2 (*); 300°C, T1 (*); 450°C
(*: Use /HT version above
250°C)
Electrical Connection : ANSI 1/2 NPT female,
ISO M20 X 1.5 female

10.4 CSA

10.4.1 Technical Data

• Explosion Proof

Applicable Standard: C22.1-98, C22.2 No.0-1991, C22.2
No.4-04, C22.2 No.0.5-1982, C22.2
No. 25-1966, C22.2 No. 30-M1986,
C22.2 No. 94-M1991, C22.2 No. 142-
M1987, C22.2 No. 61010-1-04, ANSI/
ISA-12.27.01-2003

Certificate : 1166201

Type of Protection: Explosion proof for Class I, B, C and D;
Class II, Groups E, F and G; Class III.

For Class I, Division 2 location:

“FACTORY SEALED, CONDUIT SEAL NOT
REQUIRED.”

Enclosure : Type 4X

(Integral Type Flowmeter and Remote Type Flowmeter)

Temperature Code	Ambient Temperature	Process Temperature
T6	60°C	≤85°C
T5	60°C	≤100°C
T4	60°C	≤135°C
T3	60°C	≤200°C
T2	60°C	≤300°C
T1	60°C	≤450°C

T100401_1.EPS

Temperature Code: T6 (Remote Type Converter)

Ambient Temperature: -29 to +60°C (Integral Type Flowmeter
and Remote Type Flowmeter)
-40 to +60°C (Remote Type Converter)

Power Supply: 42Vdc max. (Integral Type Flowmeter and
Remote Type Converter)

Output Supply (Integral Type Flowmeter):
Current Output; 4 to 20mAdc
Pulse Output; On=2Vdc, 200mA
Off=42Vdc, 4mA

Output Signal (Remote Type Flowmeter):
Output Signal; 30Vp-p, 100μAp-p

Input/Output signal (Remote Type Converter):
CUrrent Output; 4 to 20mAdc
Pulse; On=2Vdc, 20mA
Off=42Vdc, 4mA

Input Signal; 30Vp-p, 100μAp-p

Maximum Working Pressure: 15MPa (DY015 to DY200)
5MPa (DY200 and DY300)

Electrical Connection: ANSI 1/2 female(Special)

10.4.2 Dual Seal (Option: /CF11)

Dual Seal:

Certified by CSA to the requirement of ANSI/ISA 12.27.01
No additional sealing required.

Primary seal failure annunciation: at the O-ring seal portion
between shedder bar and amplifier housing.

10.5 TIIS

Certificate:

Model	Shedder bar Material	Integral Type Flowmeter		Remote Type Detector	Shedder bar Material	Integral Type Flowmeter		Remote Type Detector
		N (None Indicator)	D (With Indicator)	N (None Indicator)		N (None Indicator)	D (With Indicator)	N (None Indicator)
DY015 DY025/R1 DY040/R2	L	TC14901	TC14912	TC14923	-	-	-	-
	X	TC18903	TC18914	TC18925	-	-	-	-
DY025 DY040/R1 DY050/R2	L	TC14902	TC14913	TC14924	E	TC19504	TC19513	TC19522
	X	TC18904	TC18915	TC18926	-	-	-	-
DY040 DY050/R1 DY080/R2	L	TC14903	TC14914	TC14925	E	TC19505	TC19514	TC19523
	X	TC18905	TC18916	TC18927	-	-	-	-
DY050 DY080/R1 DY100/R2	L	TC14904	TC14915	TC14926	E	TC19506	TC19515	TC19524
	X	TC18906	TC18917	TC18928	-	-	-	-
DY080 DY100/R1 DY150/R2	L	TC14905	TC14916	TC14927	E	TC19507	TC19516	TC19525
	X	TC18907	TC18918	TC18929	-	-	-	-
DY100 DY150/R1 DY200/R2	L	TC14906	TC14917	TC14928	E	TC19508	TC19517	TC19526
	X	TC18908	TC18919	TC18930	-	-	-	-
DY150 DY200/R1	L	TC14907	TC14918	TC14929				
	X	TC18909	TC18920	TC18931				
DY200	L	TC14908	TC14919	TC14930				
	X	TC18910	TC18921	TC18932				
DY250	L	TC14909	TC14920	TC14931				
DY300	L	TC14910	TC14921	TC14932				
Model	Shedder bar Material	Remote Type Converter						
		N (None Indicator)	D (With Indicator)					
DYA		TC14934	TC14935					

T100403.EPS

	Integral Type Flowmeter		Remote Type Flowmeter	
	None Indicator	With Indicator	Detector	Converter
Construction	Ex d IIC T6	←	←	←
	Flame Proof Approval	←	←	←
Amb.Temp	-20°C up to -60°C	←	←	←
Rating	Maximum power supply vortage: DC42V Current Signal: DC4-20mA Pulse Signal: ON : 2V 200mA OFF : 42V 4mA		Output Voltage: 30Vp-p Output Current: 100µ Ap-p	Maximum power supply vortage: DC42V Current Signal: DC4-20mA Pulse Signal: ON : 2V 200mA OFF : 42V 4mA Input Signal: 30V p-p,100µ A p-p Resistance Temp, Sensor Input: Pt1000Ω at 0°C Specified Current: less than 1mA

T100404.EPS

* In case that ambient temperature exceeds 50 degC, use heat-resistant cables with maximum allowable temperature of 70 degC or above.