

AXR150 G - □ 1 A □ 1 □ - A □ □ 2
AXR200

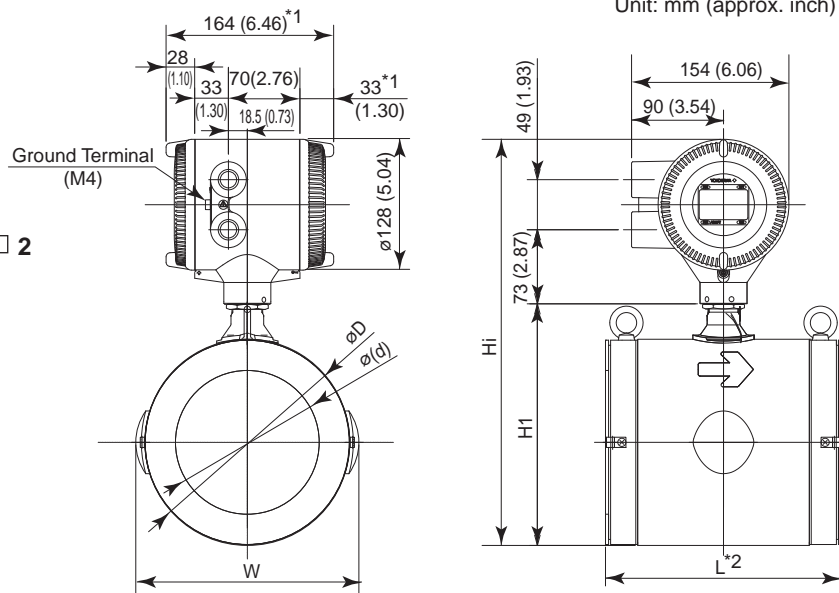

Size code		150	200
Size		150 (6)	200 (8)
Lining code		A	A
Face-to-face length	L ^{*2}	230 (9.06)	300 (11.81)
Outside dia.	ϕD	202 (7.95)	252 (9.92)
Inter diameter of Grounding ring	ϕd	140.7 (5.54)	188.9 (7.44)
Width	W	220 (8.66)	272 (10.71)
Height	H ₁	243 (9.57)	293 (11.54)
Max. Height	H _i	405 (15.93)	455 (17.89)
Weight kg (lb)		19.3 (42.5)	28.2 (62.2)

* When option code RA, RB, or RC is selected, the direction of electrical connection change as below.

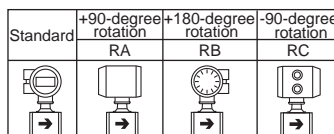

*1: When indicator code N is selected, subtract 5 mm (0.2 inch) from the value in the figure.
 *2: Depending on the selection of grounding ring code and optional code, add the following value to "L" (face-to-face length).

Grounding Ring Code	S, L, H	P, T	N
Optional Code	None	+0	+28 (1.1)
	GA, GC, GD (Special Gaskets)	+2 (0.08)	+30 (1.18)
			-6 (0.24)
			-

Terminal configuration

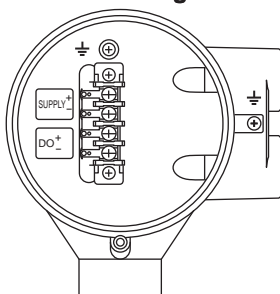

Terminal wiring

Terminal Symbols	Description
	Functional grounding
SUPPLY ⁺ -	Power supply and current output
DO ⁺ -	Digital output (One output can be selected from pulse, alarm or status outputs.)

Unless otherwise specified, difference in the dimensions are specified as : General tolerance = ± (Criteria of tolerance class IT18 in JIS B0401) / 2