

Please use the attached sheets for the page listed below in the following manual.

IM 01C25R01-01E (8th)

Page and Item	Contents of Correction
Page 7-5, 7-6 7.6.1 Connecting Shielded Cable with Cable Gland 7.6.3 Removing Shielded Cable with Cable Gland	Add the procedure for electrical connection code F (G1/2 female).
Page 10-5 10.1 Standard Specification	Change the Specification of "Degree of Protection" and "Name plate and tag".
Page 10-6, 10-7 10.2 Model and Suffix Codes	Add the electrical connection code F, 5 and A. Delete the mounting bracket code G.
Page 10-9, 10-10 10.3 Optional Specifications	Update the description. Add the Explosion Protected Optional Specification for EJX930A (FS15, KS2, CF1, SF2).

- Magnified view of the RTD connector in the transmitter's terminal box.

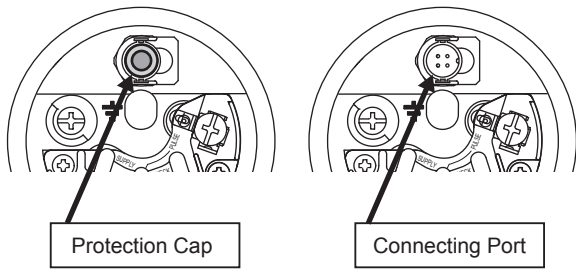

F0714.ai

The RTD cable connecting port is covered with a cap to keep out dust. The cap should not be removed until you are ready to install the cable.

CAUTION

Input/output signal is non-isolated.
Do not turn on power supply until you complete all the wiring work.

■ **In the case of electrical connection code 2 (1/2NPT female) or 4 (M20 female).**

- Components for the cable gland
The cable gland assembly consists of an entry, seal, running coupler, and backnut. Confirm that the seal is attached inside the entry and that the thread size of the cable gland is the same as that for the RTD electrical connection.

1/2NPT Type

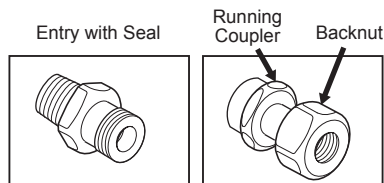

M20 Type

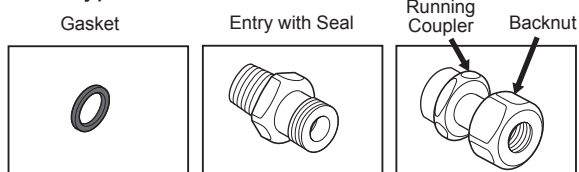

F0715.ai

Procedure

- (1) Disassemble the cable gland: loosen the running coupler to separate the backnut from the entry.
- (2) Remove the protection cap over the transmitter electrical connection and install the entry on the electrical connection. Note that a non-hardening sealant should be applied to the threads for a 1/2 NPT connection and a gasket should be used for an M20 connection.

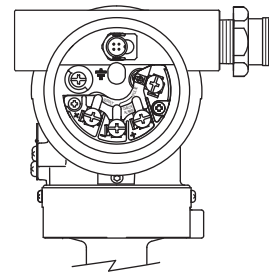

F0716.ai

- (3) Pass the RTD cable through the running coupler and backnut assembly.

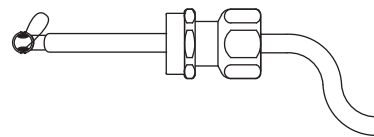

F0717.ai

- (4) Insert the RTD cable and firmly plug its connector into the connecting port in the transmitter's terminal box.

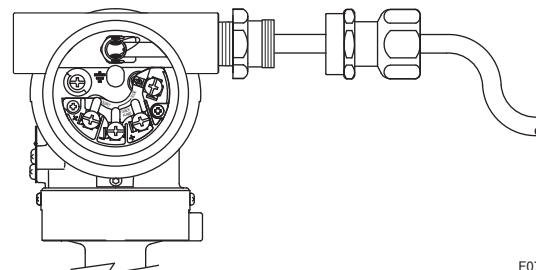

F0718.ai

- (5) Align the running coupler on the entry.

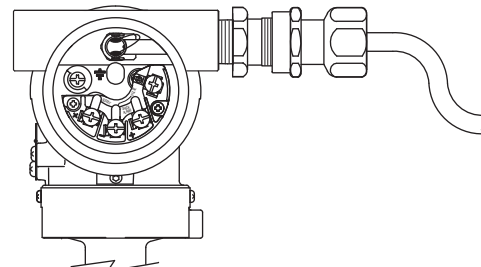

F0719.ai

- (6) Turn the running coupler until the seal in the entry comes into contact with the RTD cable.

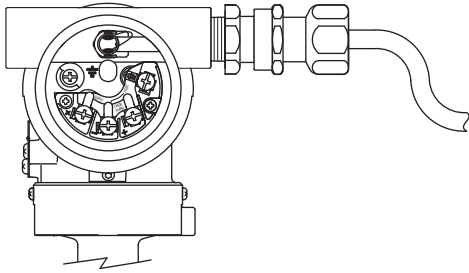

F0720.ai

- (7) Rotate the running coupler another half turn to securely tighten the seal on the RTD cable.
- (8) Use a protection conduit, if necessary. In this case, insert the cable through the conduit and attach it to the Backnut.

CAUTION

After the cable is secured as explained above, do not tighten the running coupler any further; to do so could damage the RTD connection. Do not pull the cable or subject it to excessive mechanical shock.

In the case of electrical connection code F (G1/2 female).

- Components for the cable gland
The cable gland assembly consists of an adapter body, packing box, rubber packing, washer, gland, clamp ring, clamp nut, union coupling, and union cover.
Refer to (2) and (3) shown below.
RTD cable gland is accompanied by two kinds of rubber packing.
Since the outside diameter of the RTD cable is 8.5 mm, use the rubber packing with identification mark "16 8-10" on it.

NOTE

The RTD cable can not let through the cable gland from the connector side. Insert the cable through the cable gland from the wire rods side (opposite side of RTD connector) before laying the cable.

Procedure

- (1) Disassemble the cable gland: loosen the all parts
- (2) Remove the protection cap on the RTD electrical connection and RTD connecting port, and screw the adapter body to the RTD electrical connection.

Screw the adapter body into the RTD electrical connection until the O-ring touches the RTD electrical connection (at least 6 full turns), and firmly tighten the lock nut by the wrench.

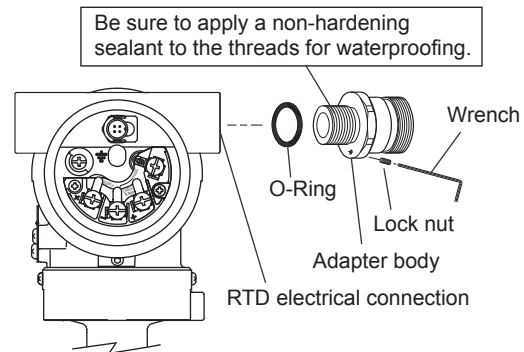

F0726.ai

- (3) Insert the RTD cable in order of a packing box, rubber packing, washer, gland, clamp ring, clamp nut, union coupling, union cover from the cable end of the wire rods side (opposite side of RTD connector).

Since the internal diameter of rubber packing has restriction, RTD connector can not pass through it, please keep this order.

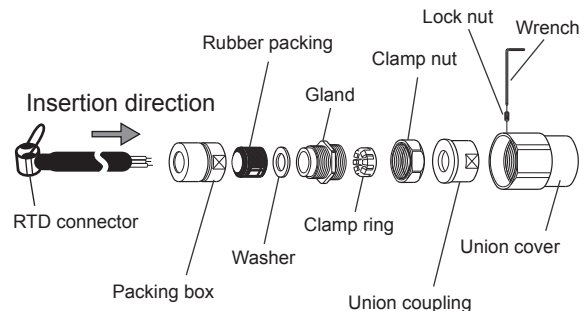

F0727.ai

- (4) Secure the RTD cable to the packing box by screwing the gland into the packing box at the position where the distance from the connector tip of the RTD cable to the packing box will be 56.5 ± 1 mm.

Tighten approximately 1 more turn surely after the cable can not move.
 The quantity of this tightening is very important. It leads to wiring disconnection fault when tighten too much.
 After that, tighten the clamp nut.

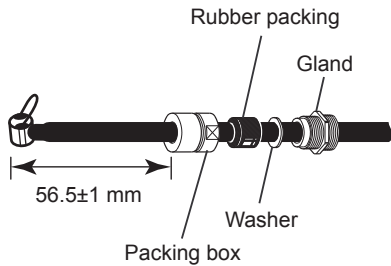

F0728.ai

- (5) Insert the RTD cable and firmly plug its connector into the connecting port in the transmitter's terminal box.
- (6) Screw the union cover to the adaptor body which has fixed to the RTD electrical connection at procedure (2).
 Screw the union cover at least 6 full turns, and tighten the rock nut.
- (7) If the conduit piping is necessary, screw the conduit to the union coupling after passing the RTD cable through the conduit.
- (8) Finally, confirm whether the connector is plugged surely.

CAUTION

After the cable is plugged as explained above, do not pull the cable or subject it to excessive mechanical shock.
 Finally, please remember to confirm whether the connector is plugged surely.

7.6.2 Connecting Shielded Cable for Conduit Use (External temperature input code: -B, -C, and -D)

- RTD connection components: EJX multivariable transmitter and RTD cable

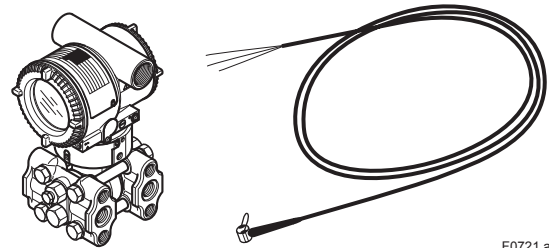

F0721.ai

Procedure

- (1) Remove the protection cap protecting the RTD electrical connection and insert the RTD cable.

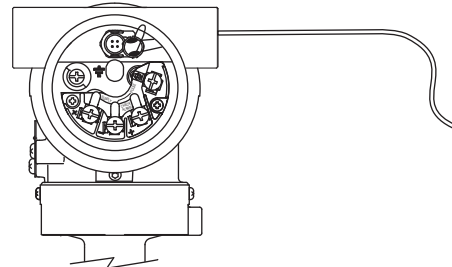

F0722.ai

- (2) Remove the cap protecting the connecting port. Then insert the RTD cable and firmly plug the connector into the connecting port in the transmitter's terminal box.
- (3) Insert the cable through the conduit and attach it to the RTD electrical connection.

CAUTION

Do not pull the cable or subject it to excessive mechanical shock.

7.6.3 Removing Shielded Cable with Cable Gland (External temperature input code: -1, -2, -3, and -4)

- (1) By pulling out the string attached to the connector, carefully unplug the connector from the transmitter's connecting port.
- (2) In the case of using 1/2NPT Type or M20 Type cable gland, remove the running coupler and backnut assembly by turning the running coupler.
In the case of using G1/2 Type cable gland, loosen the lock nut screwed into the union cover and remove the union cover. RTD cable can be pulled out together with the packing box. Loosen the clamp nut and the gland if necessary.
- (3) Pull the RTD cable out carefully.
- (4) In the case of 1/2NPT Type or M20 Type cable gland, remove the entry from the RTD electrical connection by turning the entry.
In the case of G1/2 Type cable gland, loosen the lock nut screwed into the adapter body and remove the adapter body.



NOTE
In the case of G1/2 Type cable gland, remove the rubber packing, washer, gland, clamp ring, clamp nut, union coupling and union cover from the opposite side of RTD connector in order to take out the cable gland from the RTD cable.

7.6.4 Removing Shielded Cable for Conduit Use (External temperature input code: -B, -C, -D)

- (1) By pulling out the string attached to the connector, slowly unplug the connector from the transmitter's connecting port.
- (2) Remove the conduit from the RTD electrical connection.
- (3) Pull the RTD cable out through the RTD electrical connection.

7.6.5 Cable Connection RTD Terminal Box Side

EJX multivariable transmitter RTD I/F is for 3-wire Type RTD, Pt100.

Heed the following when wiring an RTD of the 2- or 4-wire type.



NOTE
Please note that a temperature error will occur when you use a 2-wire RTD because of wiring resistance.
Please do not ground the shield on the RTD side of the cable.



CAUTION
Please use only the cables provided with this instrument.
When wiring, be sure not to damage the cable's insulation or its core.
All the cable cores must have sufficient insulation around them.
Do not let the signal line contact the shield line.
Do not allow the shield line or the signal line to come the earth potential voltage.

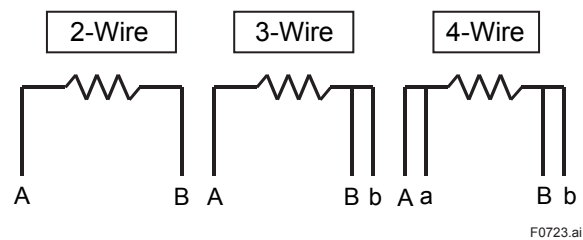

Figure 7.11 The Method of Wiring for the RTD Side

Table 7.2 The Method of Wiring for the RTD Side RTD Terminal

RTD Terminal	A	a	B	b
2-Wire	White	–	Blue1 and Blue2	–
3-Wire	White	–	Blue1	Blue2
4-Wire	White	open	Blue1	Blue2



NOTE
The color display in the table shows the white line of the cable.
The cable color could change depending on the cable type.
Blue1 and blue2 allow changing places.
For 2-wire Type, connect either which is blue1 or blue2, and give other side as OPEN.

7.7 Grounding

Grounding is always required for the proper operation of transmitters. Follow the domestic electrical requirements as regulated in each country. For a transmitter with a built-in lightning protector, grounding should satisfy ground resistance of 10Ω or less.

Ground terminals are located on the inside and outside of the terminal box. Either of these terminals may be used.

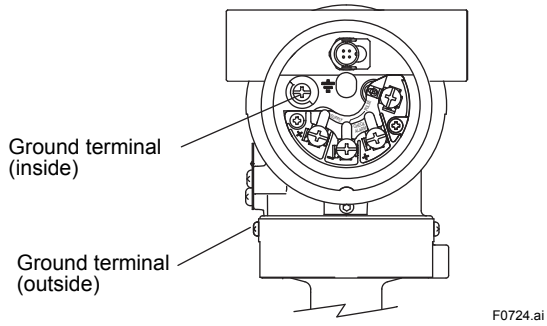
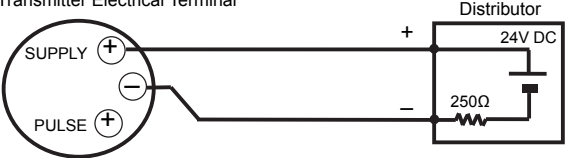
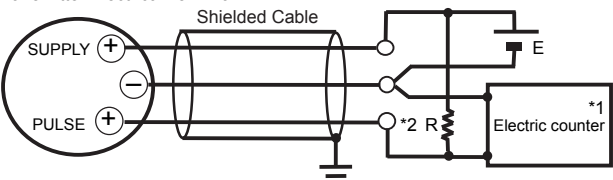
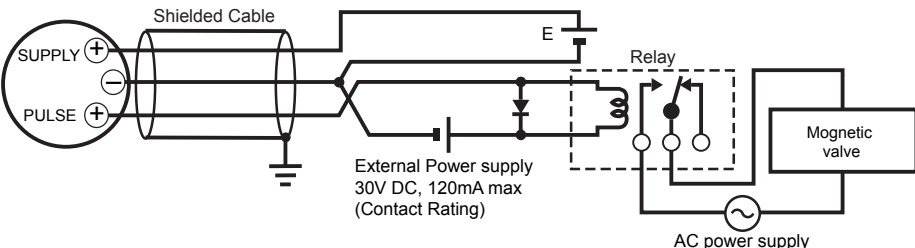
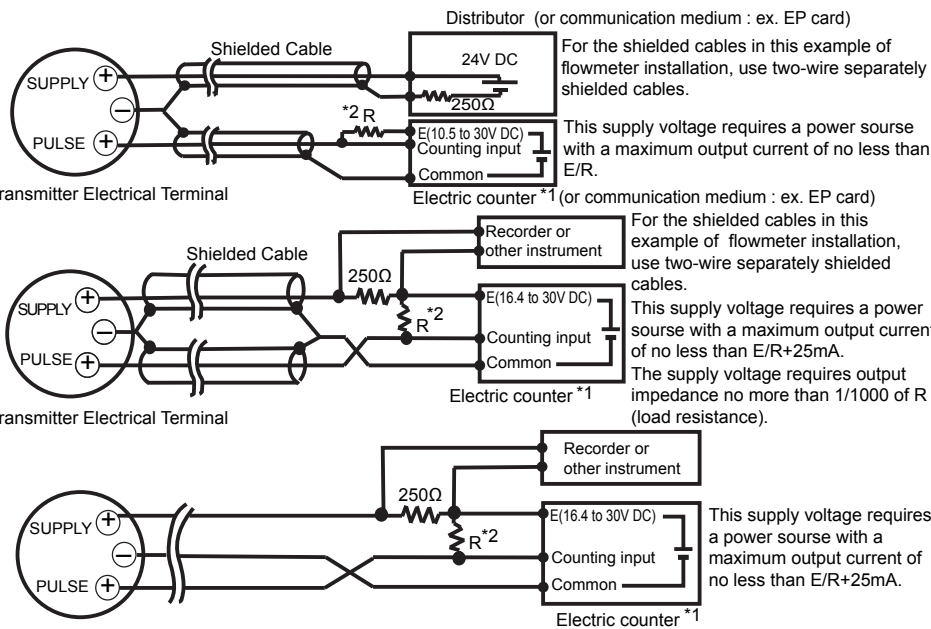

Figure 7.12 Ground Terminals

**Table 7.1 The connection example for simultaneous analog and pulse and alarm, status output.
(For HART protocol type)**

Output Type	Description
<p>Analog Output</p> <p>In this case, Communication is possible (up to a distance of 2km when a CEV cable is used.)</p>	<p>Transmitter Electrical Terminal</p>  <p>Distributor</p> <p>24V DC</p> <p>250Ω</p>
<p>Pulse Output</p> <p>In this case, No communication is possible.</p>	<p>Transmitter Electrical Terminal</p> <p>Shielded Cable</p>  <p>Use the Three-wire shielded cable.</p> <p>Electric counter *1</p>
<p>Status Output</p> <p>In this case, No communication is possible.</p>	<p>Transmitter Electrical Terminal</p> <p>Shielded Cable</p>  <p>Use the Three-wire shielded cable.</p> <p>External Power supply 30V DC, 120mA max (Contact Rating)</p> <p>Relay</p> <p>AC power supply</p> <p>Magnetic valve</p>
<p>Simultaneous Analog -Pulse Output *3</p> <p>Example 1 In this case, Communication is possible (up to a distance of 2km when a CEV cable is used).</p> <p>Example 2 In this case, Communication is possible (up to a distance of 200m when a CEV cable is used) and R = 1kΩ).</p> <p>Example 3 In this case, No communication is possible (when shielded cable is not used).</p>	<p>When analog and pulse output are used, the length of communication line is subjected to wiring conditions. Refer to example 1 to 3. If the communication carries out from amplifier, no need to consider wiring conditions.</p> <p>Distributor (or communication medium : ex. EP card)</p>  <p>For the shielded cables in this example of flowmeter installation, use two-wire separately shielded cables.</p> <p>This supply voltage requires a power source with a maximum output current of no less than E/R.</p> <p>Electric counter *1 (or communication medium : ex. EP card)</p> <p>For the shielded cables in this example of flowmeter installation, use two-wire separately shielded cables.</p> <p>This supply voltage requires a power source with a maximum output current of no less than E/R+25mA.</p> <p>The supply voltage requires output impedance no more than 1/1000 of R (load resistance).</p> <p>Recorder or other instrument</p> <p>E(16.4 to 30V DC)</p> <p>Counting input</p> <p>Common</p> <p>Electric counter *1</p> <p>Recorder or other instrument</p> <p>E(16.4 to 30V DC)</p> <p>Counting input</p> <p>Common</p> <p>Electric counter *1</p>
<p>The range of load resistance R for the pulse output.</p>	<p>The load resistance of pulse output should be used to 1kΩ, 2W.</p> <p>If no translation of the pulse output possible by the cable length or the frequency of the pulse output, the load resistance should be selected by calculation as shown below.</p> $\frac{E (V)}{120} \leq R (k\Omega) \leq \frac{0.1}{C (\mu F) \times f (kHz)}$ <p>Example of CEV cable capacitance = 0.1μF/km</p> $P (mW) = \frac{E^2 (V)}{R (k\Omega)}$ <p>Where E = Supply voltage (V) f = Frequency of pulse output (kHz) R = Value of load resistance (kΩ) C = Cable capacitance (μF) P = Power ratio of the load resistance (mW)</p>

*1: To avoid the influence of external noise, use an electric counter which fits to the pulse frequency.

*2: Resistor is not necessary in case of an electric counter which can receive contact pulse signal directly.

*3: When using analog and pulse output simultaneously, the HART communication may be influenced by noise comparing analog output only. Take countermeasure for noise shown above, e.g. use shield cable etc.

■ **Normal Operating Condition:**

(Selected features may affect limits.)

Ambient Temperature Limits

- 40 to 85°C (-40 to 185°F)
- 30 to 80°C (-22 to 176°F) with LCD display

Process Temperature Limits

- 40 to 120°C (-40 to 248°F)

Ambient Humidity Limits

- 0 to 100% RH

Working Pressure Limits (Silicone oil)

Maximum Pressure Limits

EJX910A	
L Capsule	16 MPa (2300 psi)
M and H Capsule	25 MPa (3600 psi)
EJX930A	
M and H Capsule	32 MPa (4500 psi)

Minimum Pressure Limit

See graph below

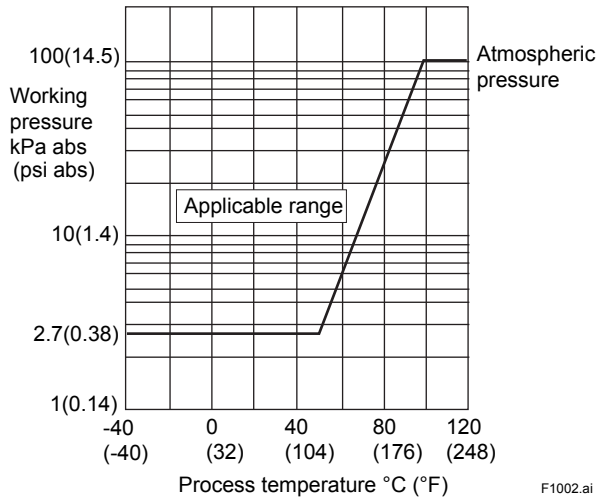

Figure 10.2 Working Pressure and Process Temperature

Supply & Load Requirements “◇”

(Optional features or safety approvals may affect electrical requirements.)

With 24 V DC supply, up to a 570 V load can be used.

See graph below.

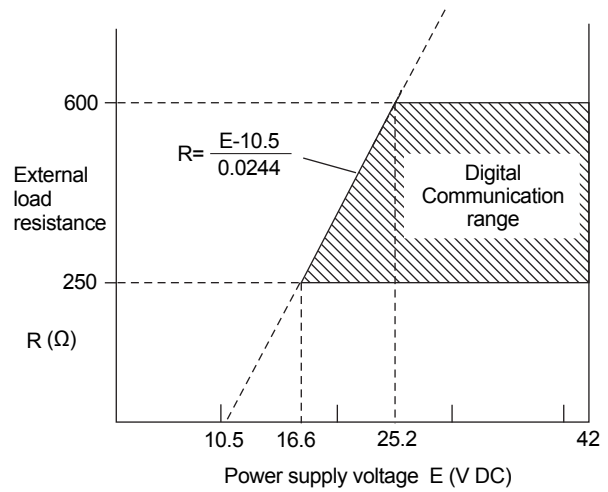

Figure 10.3 Relationship Between Power Supply Voltage and External Load Resistance

Supply Voltage

- 10.5 to 42 V DC for general use and flameproof type.
- 10.5 to 32 V DC for lightning protector (Option code /A).
- 10.5 to 30 V DC for intrinsically safe, type n or nonincendive.
- Minimum voltage limited at 16.4 V DC for HART communication.

Load (Output signal code E)

- 0 to 1335Ω for operation
- 250 to 600Ω for digital communication

EMC Conformity Standards, CE, N200

- EN61326-1 Class A, Table2 (For use in industrial locations)
- EN61326-2-3

□ **Physical Specifications**

Wetted Parts Materials

Diaphragm, Cover Flange, Process Connector, Capsule Gasket, and Vent/Drain Plug Refer to “Model and Suffix Code.”

Process Connector Gasket

PTFE Teflon

Fluorinated rubber for Option code /N2 and /N3

Non-wetted Parts Materials

Bolts

ASTM-B7 carbon steel, 316L SST stainless steel, or ASTM grade 660 stainless steel

Housing

Low copper cast aluminum alloy with polyurethane, mint-green paint (Munsell 5.6BG 3.3/2.9 or its equivalent) or ASTM CF-8M stainless steel

Degrees of Protection

IP66, IP67, NEMA4X

Cover O-rings

Buna-N, fluoro-rubber (option)

Name plate and tag

316 SST

Fill Fluid

Silicone oil, Fluorinated oil (option)

Cable for RTD

External Temperature Input Code -1, -2, -3, -4
Oil-proof and a heat-resistant cable with a shield
Outside diameter: 8.5 mm (0.335 inch),
Voltage rating: 300V
Temperature rating: –40 to 105°C (–40 to 221°F)

External Temperature Input Code -B,-C,-D
A heat-resistant FEP cable with a shield
Outside diameter: 4.3mm (0.168 inch)
Voltage rating: 300V
Temperature rating: –80 to 200°C (–112 to 392°F)
Flame resistance: NEC Article 800-CMP
Adaptation standard: NEC Article 725-PLTC

Note for using an extension cable:
When extending a temperature cable with using an extension cable and a junction box, total cable length including the original external temperature cable must be less than 25 m. Use PE or XLPE insulated cable for extension.

Cable gland

Nickel plating brass

Weight

[EJX910A]

2.8 kg (6.2 lb) without integral indicator, mounting bracket, process connector and RTD cable.

Add 1.5 kg (3.3 lb) for Amplifier housing code 2.

[EJX930A]

6.8 kg (14.3 lb) without integral indicator, mounting bracket, process connector and RTD cable.

Add 1.5 kg (3.3 lb) for Amplifier housing code 2.

Connections

Refer to “Model and Suffix Code.”

Process Connection of Cover Flange:

IEC61518

< Related Instruments >

Power Distributor: Refer to GS 01B04T01-02E or GS 01B04T02-00E

FSA120 Flow Configuration Software (FlowNavigator) GS 01C25R51-01E

< Reference >

1. Teflon; Trademark of E.I. DuPont de Nemours & Co.
2. Hastelloy; Trademark of Haynes International Inc.
3. HART; Trademark of the HART Communication Foundation.
4. AIChE, DIPPR (Design Institute for Physical Properties); Trademarks of American Institute of Chemical Engineers.
5. AGA; Trademark of American Gas Association. Other company/organization names and product names used in this material are registered trademarks or trademarks of their respective owners.

10.2 Model and Suffix Codes

Model	Suffix Codes	Description
EJX910A	Multivariable transmitter
Output signal	-E -J -F	4 to 20 mA DC with digital communication (HART protocol) ^{*8} 4 to 20 mA DC with digital communication (HART 5/HART 7 protocol) ^{*9} Digital communication (FOUNDATION Fieldbus protocol)
Measurement span (capsule)	L M H	0.1 to 10 kPa (0.4 to 40 inH ₂ O) 0.5 to 100 kPa (2 to 400 inH ₂ O) 2.5 to 500 kPa (10 to 2000 inH ₂ O)
Wetted parts material ^{*1}	S	Refer to Table 10.3
Process connections	0 1 2 3 4 5	without process connector (Rc1/4 female on the cover flanges) with Rc1/4 female process connector with Rc1/2 female process connector with 1/4 NPT female process connector with 1/2 NPT female process connector without process connector (1/4 NPT female on the cover flanges)
Bolts and nuts material	J G C	ASTM-B7M carbon steel 316L SST (ISO A4-70) stainless steel ASTM grade 660 stainless steel
Installation	-7 -8 -9 -B	Vertical piping, left side high pressure, and process connection downside Horizontal piping and right side high pressure Horizontal piping and left side high pressure Bottom Process Connection, left side high pressure
Amplifier housing	1 2	Cast aluminum alloy ASTM CF-8M Stainless steel
Electrical connection	F 2 4 5 7 9 A C D	G 1/2 female, two electrical connections (One connection for RTD) 1/2NPT female, two electrical connections (One connection for RTD) M20 female, two electrical connections (One connection for RTD) G 1/2 female, two electrical connections and a blind plug ^{*2*6*7} 1/2NPT female, two electrical connections and a blind plug ^{*2*6*7} M20 female, two electrical connections and a blind plug ^{*2*6*7} G 1/2 female, two electrical connections and a 316 SST blind plug ^{*2} 1/2 NPT female, two electrical connections and a 316 SST blind plug ^{*2} M20 female, two electrical connections and a 316 SST blind plug ^{*2}
Integral indicator	D N	Digital indicator None
Mounting bracket	B D J K M N	304 SST 2-inch pipe mounting, flat type (for horizontal piping) 304 SST 2-inch pipe mounting, L type (for vertical piping) 316 SST 2-inch pipe mounting, flat type (for horizontal piping) 316 SST 2-inch pipe mounting, L type (for vertical piping) 316 SST 2-inch pipe mounting (for bottom process connection type) None
External temperature input ^{*3}	-0 -1 -2 -3 -4 -B -C -D	Fixed temperature (without cable) ^{*5} RTD input with 0.5 m (1.64 ft) of shielded cable and two cable glands ^{*7} RTD input with 4 m (13.1 ft) of shielded cable and two cable glands ^{*7} RTD input with 7.5 m (24.6 ft) of shielded cable and two cable glands ^{*7} RTD input with 25 m (81 ft) of shielded cable and two cable glands ^{*7} RTD input with 4 m (13.1 ft) of shielded cable without cable gland ^{*4} RTD input with 7.5 m (24.6 ft) of shielded cable without cable gland ^{*4} RTD input with 25 m (81 ft) of shielded cable without cable gland ^{*4}
Measurement function	A B	Multi Sensing (DP, P and T) Mass Flow Measurement (Flow, DP, P and T)
Optional codes		/ <input type="checkbox"/> Optional specification

The "►" marks indicate the most typical selection for each specification.

*1: ⚠ Users must consider the characteristics of selected wetted parts material and the influence of process fluids. The use of inappropriate materials can result in the leakage of corrosive process fluids and cause injury to personnel and/or damage to plant facilities. It is also possible that the diaphragm itself can be damaged and that material from the broken diaphragm and the fill fluid can contaminate the user's process fluids.

Be very careful with highly corrosive process fluids such as hydrochloric acid, sulfuric acid, hydrogen sulfide, sodium hypochlorite, and high-temperature steam (150°C [302°F] or above). Contact Yokogawa for detailed information of the wetted parts material.

*2: For External Temperature Input code 0 (Fixed temperature).

*3: Recommended External Temperature Input Cable is as shown in Table 10.2. RTD is not provided.

*4: Specify when using conduit for RTD connection.

*5: Preset external temperature value is used for density compensation.

*6: Material of a blind plug is aluminum alloy or 304 SST.

*7: Not applicable for Amplifier housing code 2.

*8: Output signal code E: HART 5.

*9: Output signal code J: HART 5 or HART 7 selectable. Specify HART 5 or HART 7 when ordering. (Output signal code J is recommended for HART communication.)

Model	Suffix Codes	Description
EJX930A	Multivariable transmitter
Output signal	-E -J -F	4 to 20 mA DC with digital communication (HART protocol) *9 4 to 20 mA DC with digital communication (HART 5/HART 7 protocol) *10 Digital communication (FOUNDATION Fieldbus protocol)
Measurement span (capsule)	M H.....	1 to 100 kPa (4 to 400 inH ₂ O) 5 to 500 kPa (20 to 2000 inH ₂ O)
Wetted parts material *1	S.....	Refer to Table 10.3
Process connections	3 4 5	with 1/4 NPT female process connector *8 with 1/2 NPT female process connector *8 without process connector (1/4 NPT female on the cover flanges)
Bolts and nuts material	J G C.....	ASTM-B7 carbon steel 316L SST stainless steel ASTM grade 660 stainless steel
Installation	-7 -8 -9	Vertical piping, left side high pressure, and process connection downside Horizontal piping and right side high pressure Horizontal piping and left side high pressure
Amplifier housing	1 2.....	Cast aluminum alloy ASTM CF-8M Stainless steel
Electrical connection	F 2 4 5 7 9 A..... C..... D.....	G 1/2 female, two electrical connections (One connection for RTD) 1/2NPT female, two electrical connections (One connection for RTD) M20 female, two electrical connections (One connection for RTD) G 1/2 female, two electrical connections and a blind plug *2*6*7 1/2NPT female, two electrical connections and a blind plug *2*6*7 M20 female, two electrical connections and a blind plug *2*6*7 G 1/2 female, two electrical connections and a 316 SST blind plug *2 1/2 NPT female, two electrical connections and a 316 SST blind plug *2 M20 female, two electrical connections and a 316 SST blind plug *2
Integral indicator	D..... N.....	Digital indicator None
Mounting bracket	B..... D..... J..... K..... N.....	304 SST 2-inch pipe mounting, flat type (for horizontal piping) 304 SST 2-inch pipe mounting, L type (for vertical piping) 316 SST 2-inch pipe mounting, flat type (for horizontal piping) 316 SST 2-inch pipe mounting, L type (for vertical piping) None
External temperature input *3	-0 -1 -2 -3 -4 -B -C -D	Fixed temperature (without cable) *5 RTD input with 0.5 m (1.64 ft) of shielded cable and two cable glands *7 RTD input with 4 m (13.1 ft) of shielded cable and two cable glands *7 RTD input with 7.5 m (24.6 ft) of shielded cable and two cable glands *7 RTD input with 25 m (81 ft) of shielded cable and two cable glands RTD input with 4 m (13.1 ft) of shielded cable without cable gland *4 RTD input with 7.5 m (24.6 ft) of shielded cable without cable gland *4 RTD input with 25 m (81 ft) of shielded cable without cable gland *4
Measurement function	A.... B....	Multi Sensing (DP, P and T) Mass Flow Measurement (Flow, DP, P and T)
Optional codes		/ <input type="checkbox"/> Optional specification

The "▶" marks indicate the most typical selection for each specification.

*1: ⚠ Users must consider the characteristics of selected wetted parts material and the influence of process fluids. The use of inappropriate materials can result in the leakage of corrosive process fluids and cause injury to personnel and/or damage to plant facilities. It is also possible that the diaphragm itself can be damaged and that material from the broken diaphragm and the fill fluid can contaminate the user's process fluids.

Be very careful with highly corrosive process fluids such as hydrochloric acid, sulfuric acid, hydrogen sulfide, sodium hypochlorite, and high-temperature steam (150°C [302°F] or above). Contact Yokogawa for detailed information of the wetted parts material.

*2: For External Temperature Input code 0 (Fixed temperature) .

*3: Recommended External Temperature Input Cable is as shown in Table 10.2 RTD is not provided.

*4: Specify when using conduit for RTD connection.

*5: Preset external temperature value is used for density compensation.

*6: Material of a blind plug is aluminum alloy or 304 SST.

*7: Not applicable for Amplifier housing code 2.

*8: Lower limit of ambient and process temperature is -15°C.

*9: Output signal code E: HART 5.

*10: Output signal code J: HART 5 or HART 7 selectable. Specify HART 5 or HART 7 when ordering. (Output signal code J is recommended for HART communication.)

Table 10.2 Recommended External Temperature Cable

External Temperature Input Code		-1, -2, -3, -4	-B, -C, -D
General Application		✓	✓
Factory Mutual (FM)	Nonincendive	✓	✓
	Explosionproof Approval		✓
	Intrinsically safe Approval		✓
CENELEC ATEX	Type N	✓	
	Flameproof Approval	✓	
	Intrinsically safe Approval	✓	
Canadian Standards Association (CSA)	Explosionproof Approval		✓
IECEX Scheme	Explosionproof Approval	✓	✓

Table. 10.3 Wetted Parts Materials

[EJX910A]

Wetted parts material code	Cover flange and process connector	Capsule	Capsule gasket	Drain/Vent plug
S #	ASTM CF-8M*1	Hastelloy C-276 *2 (Diaphragm) F316L SST (Others)	Teflon-coated 316L SST	316 SST

[EJX930A]

Wetted parts material code	Cover flange	Process connector	Capsule	Capsule gasket	Drain/Vent plug
S #	F316 SST	ASTM CF-8M *1	Hastelloy C-276 *2 (Diaphragm) F316L SST (Others)	Teflon-coated 316L SST	316 SST

*1: Cast version of 316 SST. Equivalent to SCS14A.

*2: Hastelloy C-276 or N10276.

The # marks indicate the construction materials conform to NACE material recommendations per MR01-75. For the use of 316 SST material, there may be certain limitations for pressure and temperature. Please refer to NACE standards for details.

10.3 Optional Specifications

Item	Description	Code
Factory Mutual (FM)	FM Explosionproof Approval *4 Applicable Standard: FM3600, FM3615, FM3810, ANSI/NEMA 250 Explosionproof for Class I, Division 1, Groups B, C and D, Dust-ignitionproof for Class II/III, Division 1, Groups E, F and G, in Hazardous locations, indoors and outdoors (NEMA 4X) "FACTORY SEALED, CONDUIT SEAL NOT REQUIRED." Temperature class: T6, Amb. Temp.: -40 to 60°C (-40 to 140°F)*2	FF1
	FM Intrinsically Safe and Nonincendive Approval *3 *4 Applicable Standard: FM3600, FM3610, FM3611, FM3810, ANSI/NEMA 250, IEC60079-27 Intrinsically Safe for Class I,II, & III, Division 1, Groups A,B,C,D,F & G, Entity, FISCO. Class I, Zone 0, AEx ia IIC, Enclosure: "NEMA 4X", Temp. Class: T4, Amb. Temp.: -40 to 60°C (-40 to 140°F). *2 Intrinsically Apparatus Parameters: [FISCO (IIC)] Ui=17.5 V, li=380 mA, Pi=5.32 W, Ci=3.52 nF, Li=0 µH [FISCO (IIB)] Ui=17.5 V, li=460 mA, Pi=5.32 W, Ci=3.52 nF, Li=0 µH [Entity] Ui=24 V, li=250 mA, Pi=1.2 W, Ci=3.52 nF, Li=0 µH Sensor Circuit: Uo=6.51 V, lo=4 mA, Po=6 mW, Co=34 µF, Lo=500 mH Nonincendive for Class I, Division 2, Groups A, B, C and D, NIFW, FNICO Class I, Zone 2, Group IIC, NIFW, FNICO Class II, Division 2, Groups F&G, and Class III, Division 1 Enclosure: "NEMA 4X", Temp. Class: T4, Amb. Temp.: -40 to 60°C (-40 to 140°F) *2 Nonincendive Apparatus Parameters : Vmax.= 32 V, Ci = 1.76 nF, Li = 0 µH	FS15
CENELEC ATEX	CENELEC ATEX (KEMA) Flameproof Approval *4 Applicable Standard: EN 60079-0, EN 60079-1, EN 61241-0, EN 61241-1 Certificate: KEMA 07ATEX0109 II 2G, 2D Exd IIC T4, T5, T6 Ex tD A21 IP6X T85, T100, T120 Degree of protection: IP66 and IP67 Amb. Temp. (Tamb) for gas-proof: T4; -50 to 75°C (-58 to 167°F), T5; -50 to 80°C (-58 to 176°F), T6; -50 to 75°C (-58 to 167°F) *2 Max. process Temp.(Tp): T4; 120°C (248°F), T5; 100°C (212°F), T6; 85°C (185°F) Max. surface Temp. for dust-proof: T85°C (Tamb: -40 to 40°C, Tp:85°C), T100°C (Tamb: -40 to 60°C, Tp:100°C), T120°C (Tamb: -40 to 80°C, Tp:120°C) *2	KF21
	CENELEC ATEX (KEMA) Intrinsically safe Approval *1 *4 Applicable Standard: EN 50014, EN 50020, EN 50284, EN 50281-1-1 Certificate: KEMA 06ATEX0037X II 1G, 1D EEx ia IIC T4 Degree of protection: IP66 and IP67 Amb. Temp. (Tamb) for gas-proof: -50 to 60°C (-58 to 140°F) *2 Maximum Process Temp.(Tp) for gas-proof: 120°C Electrical data: [Supply/Output circuit (terminals + and -)] Ui=30 V, li=200 mA, Pi=0.9 W, Ci=10 nF, Li=0 mH [Pulse Output circuit (terminals - and pulse)] Ui=30 V, li=200 mA, Pi=0.9 W, Ci=10 nF, Li=0 mH [External Temperature Input circuit (connector)] Uo=30 V, lo=95.4 mA, Po=468 mW, Co=11 nF, Lo=3.9 mH Max. surface Temp. for dust-proof: T85°C (Tamb: -40 to 60°C, Tp: 80°C), T100°C (Tamb: -40 to 60°C, Tp: 100°C), T120°C (Tamb: -40 to 60°C, Tp: 120°C) *2	KS2
	Combined KF21, KS2 and Type n *1 *4 *5 Type n Applicable Standard: EN 60079-15 Referential Standard: IEC 60079-0 II 3G Ex nL IIC T4, Amb. Temp.: -50 to 60 deg C *2 [Supply and Pulse circuit] Ui=30 V DC, Ci=10 nF, Li=0 mH [Sensor circuit] Uo=7.4 V DC, lo=25 mA, Po=46.3 mW, Co=11 nF, Lo=3.9 mH	KU21

Item	Description	Code
CENELEC ATEX	CENELEC ATEX (KEMA) Intrinsically safe Approval *3 *4 *5 Applicable standards: EN 60079-0:2006, EN 50020:2002, EN 60079-27:2006, EN 50284:1999, EN 50281-1-1:1998+A1 Certificate: KEMA 06ATEX0278X II 1GD Ex ia IIB/IIC T4 Degree of protection: IP66 and IP67 Amb. Temp.: -40 to 60°C (-40 to 140°F) *2 Max. Process Temp. (Tp): 120°C (248°F) Electrical data: Supply/Output circuit (terminals + and -) [FISCO (IIC)] Ui=17.5 V, Ii=380 mA, Pi=5.32 W, Ci=1.76 nF, Li=0 µH [FISCO (IIB)] Ui=17.5 V, Ii=460 mA, Pi=5.32 W, Ci=1.76 nF, Li=0 µH [Entity] Ui=24 V, Ii=250 mA, Pi=1.2 W, Ci=1.76 nF, Li=0 µH External Temperature Input circuit (connector) Uo=7.63 V, Io=3.85 mA, Po=8 mW, Co=4.8 µF, Lo=100 mH Max. Surface Temp. for dust-proof: T85°C (Tp:80°C), T100°C (Tp:100°C), T120°C (Tp:120°C)	KS25
Canadian Standards Association (CSA)	CSA Explosionproof Approval *4 Certificate: 2014354 Applicable Standard: C22.2 No.0, C22.2 No.0.4, C22.2 No.0.5, C22.2 No.25, C22.2 No.30, C22.2 No.94, C22.2 No.60079-0, C22.2 No.60079-1, C22.2 No.61010-1-04 Explosion-proof for Class I, Groups B, C and D. Dustignition-proof for Class II/III, Groups E, F and G. When installed in Division 2, "SEAL NOT REQUIRED" Enclosure: TYPE 4X, Temp. Code: T6...T4 Ex d IIC T6...T4 Enclosure: IP66 and IP67 Max.Process Temp.: T4;120°C (248°F), T5; 100°C (212°F), T6; 85°C (185°F) Amb.Temp.: -50 to 75°C (-58 to 167°F) for T4, -50 to 80°C (-58 to 176°F) for T5, -50 to 75°C (-58 to 167°F) for T6 *2 Process Sealing Certification Dual Seal Certified by CSA to the requirement of ANSI/ISA 12.27.01 No additional sealing required Primary seal failure annunciation: at the zero adjustment screw	CF1
	CSA Intrinsically safe Approval *1 *6	—
IECEx Scheme	IECEx Flameproof Approval *4 Applicable Standard: IEC 60079-0:2004, IEC60079-1:2003 Certificate: IECEx CSA 07.0008 Flameproof for Zone 1, Ex d IIC T6...T4 Enclosure: IP66 and IP67 Max.Process Temp.: T4;120°C (248°F), T5;100°C (212°F), T6; 85°C (185°F) Amb.Temp.: -50 to 75°C (-58 to 167°F) for T4, -50 to 80°C (-58 to 176°F) for T5, -50 to 75°C (-58 to 167°F) for T6 *2	SF2

Contact Yokogawa representative for the codes indicated as '—'

- *1: Not Applicable for output signal code -F.
- *2: Lower limit of ambient temperature is -15°C(5°F) when /HE is specified.
- *3: Not Applicable for output signal code -E and J.
- *4: Applicable for electrical connection code 2, 4, 7, 9, C and D.
- *5: Not Applicable for EJX930A.
- *6: Pending

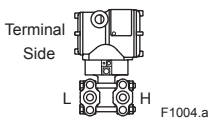
Item		Description	Code	
Painting	Color change	Amplifier cover only	P□	
		Amplifier cover and terminal cover, Munsell 7.5 R4/14	PR	
	Coating change	Anti-corrosion coating*1	X2	
316 SST exterior parts		316 SST name plate, tag plate and zero-adjustment screw*17	HC	
Fluoro-rubber O-ring		All O-rings of amplifier housing. Lower limit of ambient temperature: -15°C(5°F)	HE	
Lightning protector		Transmitter power supply voltage: 10.5 to 32 V DC Allowable current: Max. 6000 A (1×40 μs), Repeating 1000 A (1×40 μs) 100 times Applicable Standards: IEC 61000-4-4, IEC 61000-4-5	A	
Oil-prohibited use *2		Degrease cleansing treatment	K1	
		Degrease cleansing treatment with fluorinated oilfilled capsule. Operating temperature -20 to 80°C(-4 to 176°F)	K2	
Oil-prohibited use with dehydrating treatment *2		Degrease cleansing and dehydrating treatment	K5	
		Degrease cleansing and dehydrating treatment with fluorinated oilfilled capsule. Operating temperature -20 to 80°C(-4 to 176°F)	K6	
Capsule fill fluid		Fluorinated oil filled in capsule Operating temperature -20 to 80°C(-4 to 176°F)	K3	
Calibration units *3		P calibration (psi unit)	(See Table for Span and Range Limits.)	
		bar calibration (bar unit)		
		M calibration (kgf/cm ² unit)		
Gold-plated diaphragm		Surface of isolating diaphragm is gold plated, effective for hydrogen permeation.	A1	
Long vent *4		Total length: 119 mm (standard: 34 mm); Total length when combining with option code K1, K2, K5, and K6: 130 mm. Material: 316 SST	U1	
Output limits and failure operation *5		Failure alarm down-scale: Output status at CPU failure and hardware error is -2.5%, 3.6 mA DC or less.	C1	
		NAMUR NE43 Compliant Output signal limits: 3.8 mA to 20.5 mA	Failure alarm down-scale: Output status at CPU failure and hardware error is -2.5%, 3.6 mA DC or less.	C2
			Failure alarm up-scale: Output status at CPU failure and hardware error is 110%, 21.6 mA or more.	C3
Body option*6 		Right side high pressure, without drain and vent plugs	N1	
		N1 and Process connection, based on IEC61518 with female thread on both sides of cover flange, with blind kidney flanges on back.	N2	
		N2, and Material certificate for cover flange, diaphragm, capsule body, and blind kidney flange	N3	
Stainless steel tag plate		304 SST tag plate wired onto transmitter (316 SST when/HC is specified)	N4	
Data configuration at factory *7		Data configuration for HART communication type	Software damping, Descriptor, Message	
		Data configuration for Fieldbus communication type	Software damping	
PID function *15		PID control function	LC1	
Advanced diagnostics		Multi-sensing process monitoring • Impulse line blockage detection *19 • Heat trace monitoring	HART communication type	
			Fieldbus communication type *18	
Software downloading function *15		Based on FOUNDATION Fieldbus Specification (FF-883) Download class: Class1	EE	
European Pressure Equipment Directive *16		PED 97/23/EC Category III, Module H, type of equipment: Pressure accessory-vessel, Type of fluid: Liquid and Gas, Group of fluid: 1 and 2 Lower limit of Process and Ambient temperature for EJX910A: -29°C	PE3	
Material certificate *8		Cover flange *9	M01	
		Cover flange, Process connector *10	M11	
Pressure test Leak test certificate *11		Test Pressure: 16 MPa (2300 psi) *12	Nitrogen (N ₂) Gas *14 Retention time: one minute	
		Test Pressure: 25 MPa (3600 psi) *13		
		Test Pressure: 32 MPa (4500 psi) *21	Nitrogen (N ₂) Gas or Water *20 Retention time: one minute	

Please use this manual change for the manuals listed below.

1. Applicable manuals and pages

IM No. and Edition	Products	Applicable item in 2				
		(1)	(2)	(3)	(4)	(5)
		Page	Page	Page	Page	Page
IM 01C25B01-01E (10th)	EJX110A, EJX120A, EJX130A, EJX310A, EJX430A and EJX440A	2-3	9-4	9-5 to 9-10	—	—
IM 01C25C01-01E (7th)	EJX210A	2-3	9-4	9-5	—	—
IM 01C25F01-01E (7th)	EJX510A, EJX530A, EJX610A, EJX630A	2-3	9-4	9-5 and 9-6	—	—
IM 01C25H01-01E (6th)	EJX118A and EJX438A	2-3	8-4	8-5 and 8-6	—	—
IM 01C25K01-01E (3rd)	EJX115A	2-3	9-3	9-4	—	—
IM 01C25R01-01E (8th)	EJX910A and EJX930A	3-3	10-4	—	10-5 and 10-6	—
IM 01C25R03-01E (7th)	EJX910A Fieldbus Communication Type	2-1	—	—	—	A-39
IM 01C25T02-01E (10th)	EJX series Fieldbus Communication Type	2-1	—	—	—	A4-4

2. Contents of Change

(1)

Please add the following descriptions in the section of "Installation of an Explosion-protected Instrument" in the applicable pages.



IMPORTANT

All the blind plugs which accompany the EJX transmitters upon shipment from the factory are certified by the applicable agency in combination with the EJX series transmitters. The plugs which are marked with the symbols "◇ Ex" on their surfaces are certified only in combination with the EJX series transmitters.

(2)

Please use the following information in place of the corresponding part on the applicable pages.

Nameplate and tag

316SST (including /N4 wired tag)

(3)

Please add the following information in the corresponding part of the table on the applicable pages.

Amplifier Housing	3	Cast aluminum alloy with corrosion resistance properties
-------------------	---------	--

(4)

Please add the following information in the corresponding part of the table on the applicable pages.

Electrical connection	F	G1/2 female, two electrical connections (One connection for RTD)
	5	G1/2 female, two electrical connections and a blind plug*2*6*7
	A	G1/2 female, two electrical connections and a 316SST blind plug*2

(5)

Please use the following information in place of the description of "10) Polynominal computation" on the applicable pages.

10) Polynominal computation

$$\text{func} = \text{PV} + \text{GAIN_IN_1} \times \text{PV2} + \text{GAIN_IN_2} \times \text{PV3} + \text{GAIN_IN_3} \times \text{PV4}$$