

Unit: mm(approx. inch)

● EJX110A [Style: S3] (Wetted Parts Material Code: S)

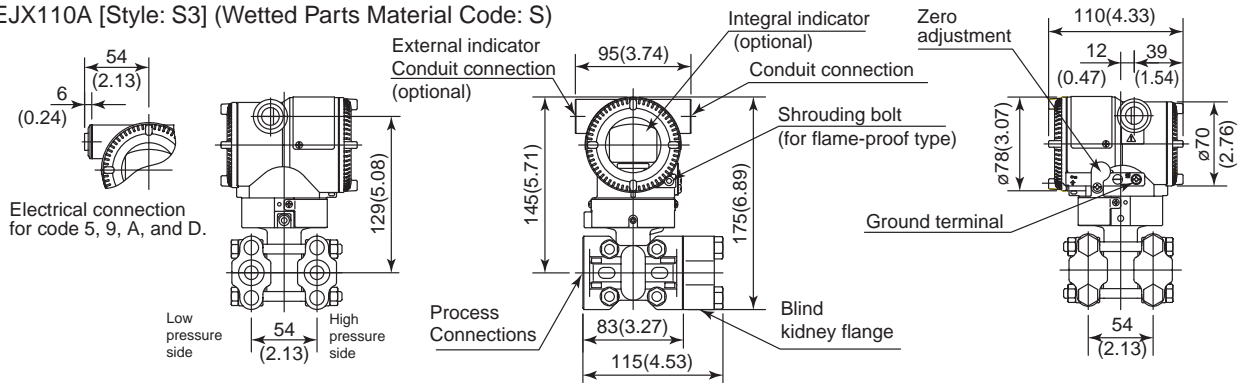

● EJX120A and EJX110A [Style: S3] (Wetted Parts Material Code: H, M, T)

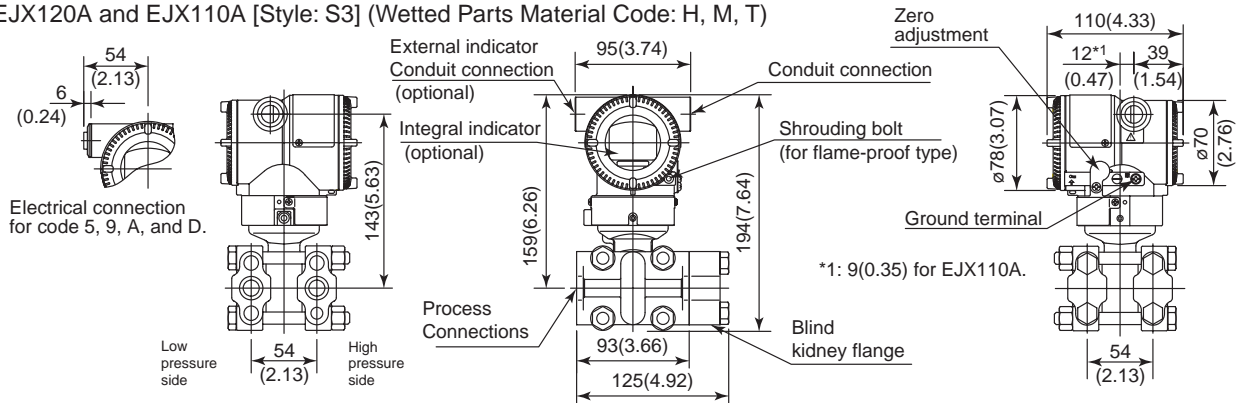

● EJX130A [Style: S2]

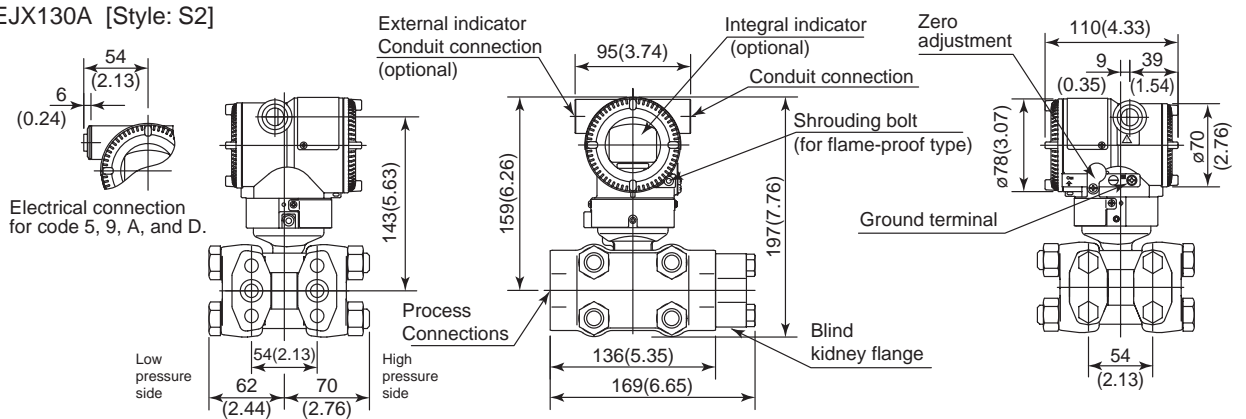

● Terminal Configuration

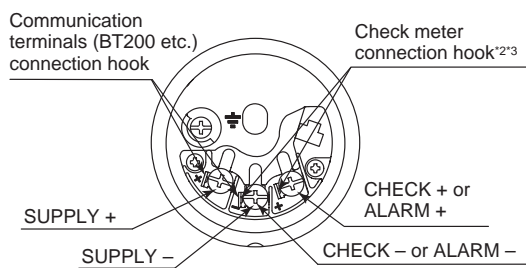

● Terminal Wiring

SUPPLY	+	Power supply and output terminal
CHECK	+	External indicator (ammeter) terminal ^{2,3}
	-	or
ALARM	+	Status contact output terminal ³
	-	(when /AL is specified)
	⏏	Ground terminal

*2: When using an external indicator or check meter, the internal resistance must be 10 Ω or less. A check meter or indicator cannot be connected when /AL option is specified.

*3: Not available for fieldbus communication type.