

Unit: mm(approx. inch)

● Flushing connection ring code 0 (No ring)

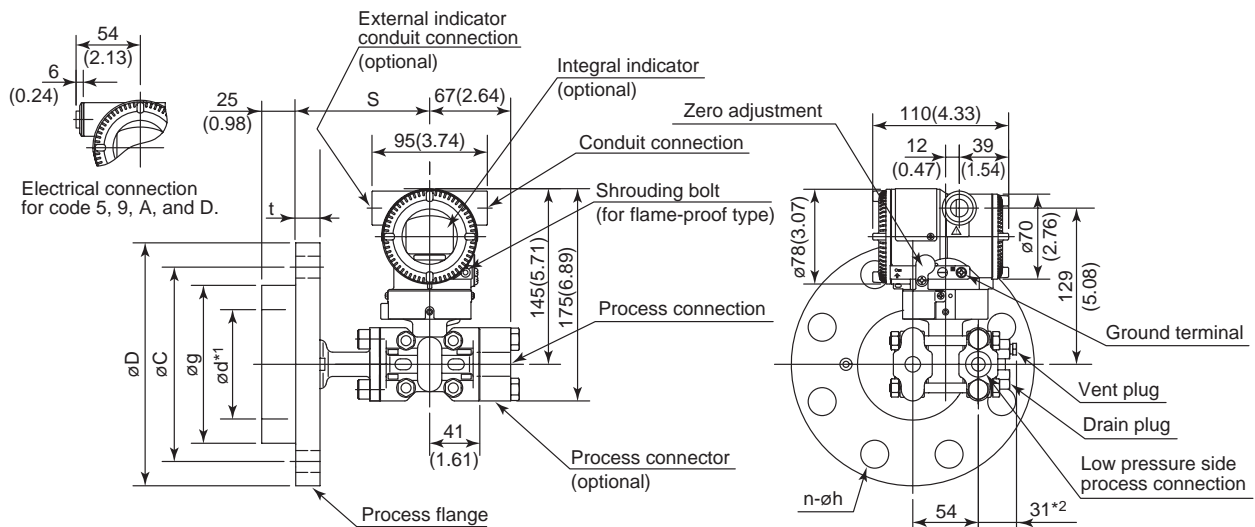

*1: Indicates inside diameter of gasket contact surface.

*2: When Option code K1, K2, K5, or K6 is selected, add 15 mm(0.59 inch) to the value in the flange.

Flange size: 3-inch (80mm)

Flange Rating	øD	øC	øg	ød	t	Bolt holes	
						No.(n)	Dia.(øh)
JIS 10K	185(7.28)	150(5.91)	130(5.12)	90(3.54)	18(0.71)	8	19(0.75)
JIS 20K	200(7.87)	160(6.30)	130(5.12)	90(3.54)	22(0.87)	8	23(0.91)
ANSI Class 150	190.5(7.50)	152.4(6.00)	130(5.12)	90(3.54)	23.9(0.94)	4	19.1(0.75)
ANSI Class 300	209.6(8.25)	168.1(6.62)	130(5.12)	90(3.54)	28.5(1.12)	8	22.4(0.88)
JPI Class 150	190(7.48)	152.4(6.00)	130(5.12)	90(3.54)	24(0.94)	4	19(0.75)
JPI Class 300	210(8.27)	168.1(6.62)	130(5.12)	90(3.54)	28.5(1.12)	8	22(0.87)
DIN PN 10/16	200(7.87)	160(6.30)	130(5.12)	90(3.54)	20(0.79)	8	18(0.71)
DIN PN 25/40	200(7.87)	160(6.30)	130(5.12)	90(3.54)	24(0.94)	8	18(0.71)

Flange size: 2-inch (50mm)

Flange Rating	øD	øC	øg	ød	t	Bolt holes	
						No.(n)	Dia.(øh)
JIS 10K	155(6.10)	120(4.72)	100(3.94)	61(2.40)	16(0.63)	4	19(0.75)
JIS 20K	155(6.10)	120(4.72)	100(3.94)	61(2.40)	18(0.71)	8	19(0.75)
ANSI Class 150	152.4(6.00)	120.7(4.75)	100(3.94)	61(2.40)	19.1(0.75)	4	19.1(0.75)
ANSI Class 300	165.1(6.50)	127(5.00)	100(3.94)	61(2.40)	22.4(0.88)	8	19.1(0.75)
JPI Class 150	152(5.98)	120.6(4.75)	100(3.94)	61(2.40)	19.5(0.77)	4	19(0.75)
JPI Class 300	165(6.50)	127(5.00)	100(3.94)	61(2.40)	22.5(0.89)	8	19(0.75)
DIN PN 10/16	165(6.50)	125(4.92)	100(3.94)	61(2.40)	18(0.71)	4	18(0.71)
DIN PN 25/40	165(6.50)	125(4.92)	100(3.94)	61(2.40)	20(0.79)	4	18(0.71)

	Fill fluid code	S
General use	B and P	113(4.45)
High temperature use	A	143(5.63)

● Terminal Configuration

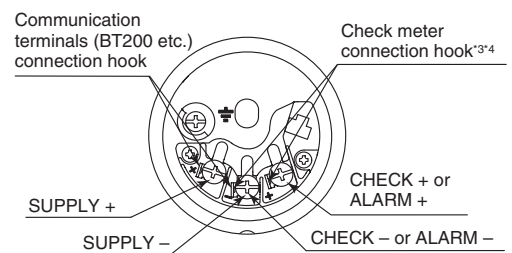

● Terminal Wiring

SUPPLY +	+	Power supply and output terminal
CHECK + or ALARM +	+	External indicator (ammeter) terminal ^{*3*} or Status contact output terminal ^{*4} (when /AL is specified)
CHECK - or ALARM -	-	
⏏		Ground terminal

*3: When using an external indicator or check meter, the internal resistance must be 10 Ω or less. A check meter or indicator cannot be connected when /AL option is specified.

*4: Not available for fieldbus communication type.