

Drawings

EJX210A Flange Mounted Differential Pressure Transmitter (Flush type with ring)

DP **harp** EJX™

[Style: S2]

● Flushing connection ring code A, B, C, and D (With ring)

Unit: mm(approx. inch)

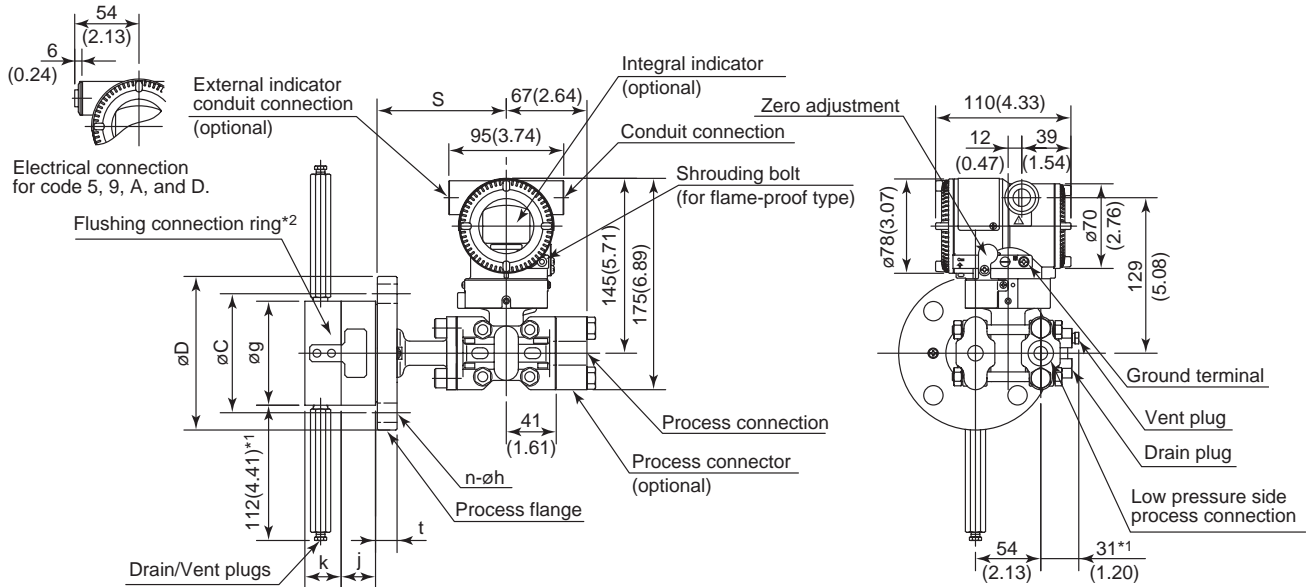

	Fill fluid code	S
General use	B and P	113(4.45)
High temperature use	A	143(5.63)

*1: When Option code K1, K2, K5, or K6 is selected, add 15 mm(0.59 inch) to the value in the flange. Add 11mm(0.43 inch) for Drain/vent plugs of flushing connection ring.

Flange size: 3-inch (80mm)

Flange Rating	øD	øC	øg	ød	t	Bolt holes		j	k
						No.(n)	Dia.(øh)		
JIS 10K	185(7.28)	150(5.91)	130(5.12)	90(3.54)	18(0.71)	8	19(0.75)	25(0.98)	27(1.06)
JIS 20K	200(7.87)	160(6.30)	130(5.12)	90(3.54)	22(0.87)	8	23(0.91)	25(0.98)	27(1.06)
ANSI Class 150	190.5(7.50)	152.4(6.00)	130(5.12)	90(3.54)	23.9(0.94)	4	19.1(0.75)	25(0.98)	27(1.06)
ANSI Class 300	209.6(8.25)	168.1(6.62)	130(5.12)	90(3.54)	28.5(1.12)	8	22.4(0.88)	25(0.98)	27(1.06)
JPI Class 150	190(7.48)	152.4(6.00)	130(5.12)	90(3.54)	24(0.94)	4	19(0.75)	25(0.98)	27(1.06)
JPI Class 300	210(8.27)	168.1(6.62)	130(5.12)	90(3.54)	28.5(1.12)	8	22(0.87)	25(0.98)	27(1.06)
DIN PN 10/16	200(7.87)	160(6.30)	130(5.12)	90(3.54)	20(0.79)	8	18(0.71)	25(0.98)	27(1.06)
DIN PN 25/40	200(7.87)	160(6.30)	130(5.12)	90(3.54)	24(0.94)	8	18(0.71)	25(0.98)	27(1.06)

Flange size: 2-inch (50mm)

Flange Rating	øD	øC	øg	ød	t	Bolt holes		j	k
						No.(n)	Dia.(øh)		
JIS 10K	155(6.10)	120(4.72)	100(3.94)	61(2.40)	16(0.63)	4	19(0.75)	25(0.98)	27(1.06)
JIS 20K	155(6.10)	120(4.72)	100(3.94)	61(2.40)	18(0.71)	8	19(0.75)	25(0.98)	27(1.06)
ANSI Class150	152.4(6.00)	120.7(4.75)	100(3.94)	61(2.40)	19.1(0.75)	4	19.1(0.75)	25(0.98)	27(1.06)
ANSI Class300	165.1(6.50)	127(5.00)	100(3.94)	61(2.40)	22.4(0.88)	8	19.1(0.75)	25(0.98)	27(1.06)
JPI Class150	152(5.98)	120.6(4.75)	100(3.94)	61(2.40)	19.5(0.77)	4	19(0.75)	25(0.98)	27(1.06)
JPI Class300	165(6.50)	127(5.00)	100(3.94)	61(2.40)	22.5(0.89)	8	19(0.75)	25(0.98)	27(1.06)
DIN PN 10/16	165(6.50)	125(4.92)	100(3.94)	61(2.40)	18(0.71)	4	18(0.71)	25(0.98)	27(1.06)
DIN PN 25/40	165(6.50)	125(4.92)	100(3.94)	61(2.40)	20(0.79)	4	18(0.71)	25(0.98)	27(1.06)

Flange size: 1 1/2-inch (40mm)

Flange Rating	øD	øC	øg	ød	t	Bolt holes		j	k
						No.(n)	Dia.(øh)		
JIS 10K	140(5.51)	105(4.13)	86(3.39)	44(1.73)	16(0.63)	4	19(0.75)	27(1.06)	30(1.18)
JIS 20K	140(5.51)	105(4.13)	86(3.39)	44(1.73)	18(0.71)	4	19(0.75)	27(1.06)	30(1.18)
ANSI Class150	127(5.00)	98.6(3.88)	86(3.39)	44(1.73)	17.5(0.69)	4	15.7(0.62)	27(1.06)	30(1.18)
ANSI Class300	155.4(6.12)	114.3(4.50)	86(3.39)	44(1.73)	20.6(0.81)	4	22.4(0.88)	27(1.06)	30(1.18)
JPI Class150	127(5.00)	98.6(3.88)	86(3.39)	44(1.73)	17.6(0.69)	4	16(0.63)	27(1.06)	30(1.18)
JPI Class300	155(6.10)	114.3(4.50)	86(3.39)	44(1.73)	20.6(0.81)	4	22(0.87)	27(1.06)	30(1.18)

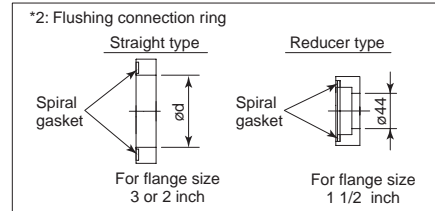

● Terminal Configuration

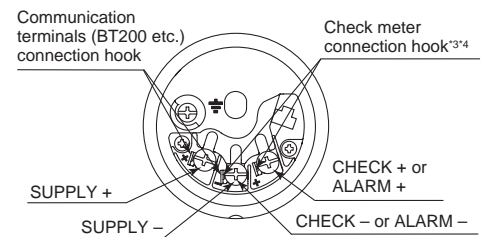

● Terminal Wiring

SUPPLY +	Power supply and output terminal
CHECK + or ALARM +	External indicator (ammeter) terminal ^{3,4} or Status contact output terminal ⁴ (when /AL is specified)
⏏	Ground terminal

*3: When using an external indicator or check meter, the internal resistance must be 10 Ω or less. A check meter or indicator cannot be connected when /AL option is specified.

*4: Not available for fieldbus communication type.