

Drawings

EJX438A Diaphragm Sealed Gauge Pressure Transmitter (Transmitter body section)

DP **harp** EJX™

[Style: S2]

Unit: mm(approx. inch)

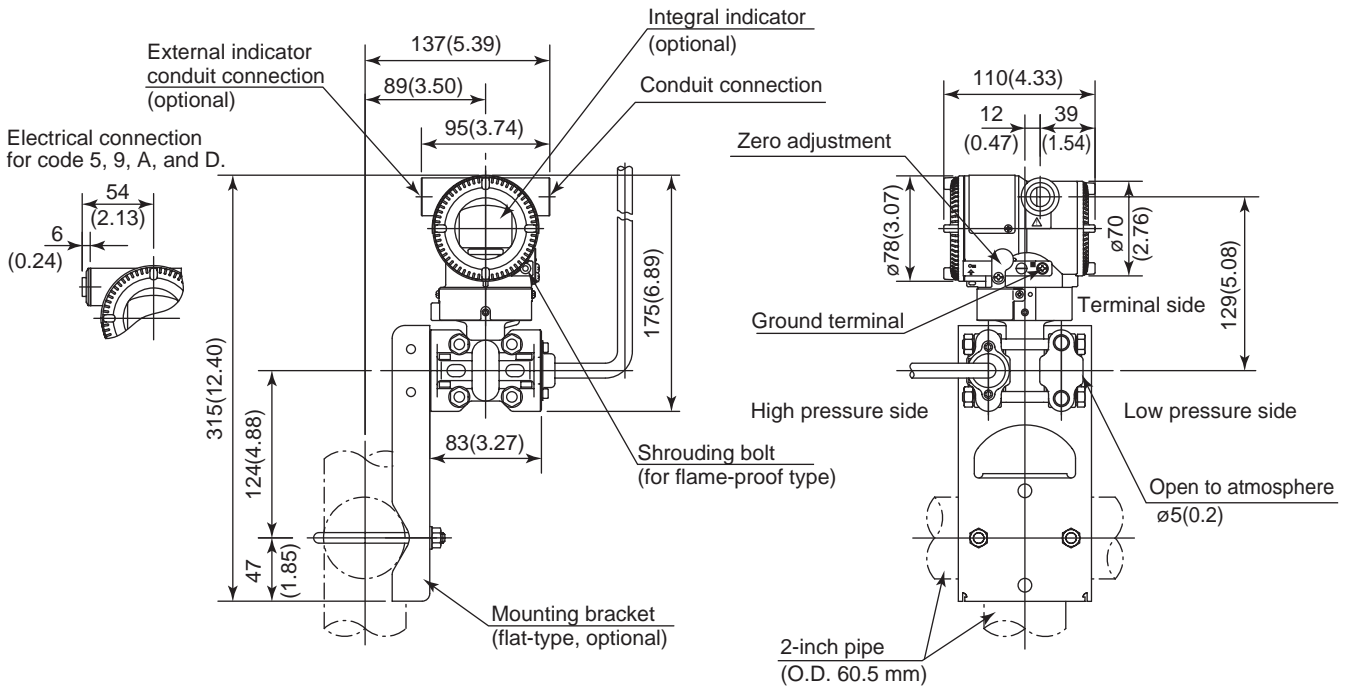

● Terminal Configuration

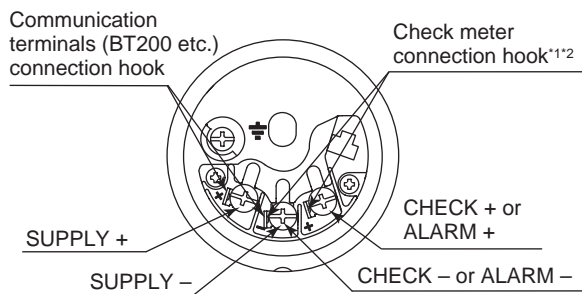

● Terminal Wiring

SUPPLY	+ -	Power supply and output terminal
CHECK or ALARM	+ - + -	External indicator (ammeter) terminal ^{*1*2} or Status contact output terminal ^{*2} (when /AL is specified)
	---	Ground terminal

*1: When using an external indicator or check meter, the internal resistance must be 10 Ω or less. A check meter or indicator cannot be connected when /AL option is specified.

*2: Not available for fieldbus communication type.