

Basic Usage Digital Multimeters

Voltage/Resistance Measurement

The COM terminal and V/ terminal are used. To measure a voltage, set the dial to voltage measurement. To measure a resistance, set the dial to resistance measurement. Some DMM models can also display the frequency and calculated decibel value at the same time when measuring an AC voltage. During resistance measurement, it is possible to switch the function to checking of the continuity of the measured circuit.

Measuring a Voltage and Resistance

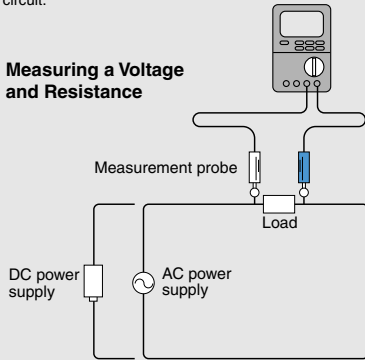

Current Measurement

The COM terminal, and A, μA or mA terminal are used. Some models have shutters for preventing erroneous insertion into the current terminals and allow a contact of a lead to a current terminal only when the dial is set to current measurement. For these models, you cannot set the dial to voltage measurement while a lead is inserted into a current terminal. This feature provides greater safety.

Measuring a Current

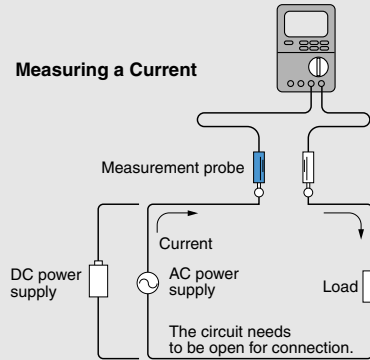

Diode Test

A current flows through a diode when the power supply is connected as (1) below, while, almost no current flows when the power supply is connected as (2). The diode test function applies an adequate forward voltage across a diode to make a constant current flow and measures the voltage drop in the forward direction to determine the forward and reverse directions of the diode.

Checking the Polarity of a Diode

