

Please read through this instruction manual before starting operation in order to ensure correct and effective use of Model 3213A Insulation Tester.

Yokogawa Meters & Instruments Corporation  
International Sales Dept.  
Tachihi Bld. No.2, 6-1-3, Sakaecho, Tachikawa-shi, Tokyo 190-8586 Japan  
Phone: 81-42-534-1413, Facsimile: 81-42-534-1426  
YOKOGAWA CORPORATION OF AMERICA (U.S.A.)  
Phone: 1-770-253-7000 Facsimile: 1-770-251-2088  
YOKOGAWA EUROPE B. V. (THE NETHERLANDS)  
Phone: 31-334-64-1611 Facsimile: 31-334-64-1610  
YOKOGAWA ENGINEERING ASIA PTE. LTD. (SINGAPORE)  
Phone: 65-6241-9833 Facsimile: 65-6241-2606  
YOKOGAWA AMERICA DO SUL S. A. (BRAZIL)  
Phone: 55-11-5681-2400 Facsimile: 55-11-5681-1274  
YOKOGAWA MEASURING INSTRUMENTS KOREA CORPORATION (KOREA)  
Phone: 82-2-551-0660 to -0664 Facsimile: 82-2-551-0665  
YOKOGAWA AUSTRALIA PTY. LTD. (AUSTRALIA)  
Phone: 61-2-9805-0699 Facsimile: 61-2-9888-1844  
YOKOGAWA INDIA LTD. (INDIA)  
Phone: 91-80-4158-6000 Facsimile: 91-80-2852-1441  
YOKOGAWA SHANGHAI TRADING CO., LTD. (CHINA)  
Phone: 86-21-6880-8107 Facsimile: 86-21-6880-4987  
YOKOGAWA MIDDLE EAST E. C. (BAHRAIN)  
Phone: 973-358100 Facsimile: 973-336100  
LTD. YOKOGAWA ELECTRIC (RUSSIAN FEDERATION)  
Phone: 7-095-737-7868 Facsimile: 7-095-737-7869

IM3E-2006.2

1st Edition : June 1994 (YG)  
All Rights Reserved, Copyright © 1994, Yokogawa M&C Corporation

A3

**YOKOGAWA**  
Yokogawa Meters & Instruments Corporation

IM 321341-01E  
4th Edition: Jan. 2007

## Safety Precautions

■ For safe use of this tester, the following safety symbols are used in the user's manual:

 **Danger! Handle with Care.**  
This symbol indicates that the operator must refer to an explanation in the user's manual in order to avoid risk of injury or death of personnel or damage to the tester.

 **High-voltage Terminal**  
This symbol indicates a dangerous voltage level (terminals with voltages exceeding 1000 volts must be so marked). Never touch the terminals.

**WARNING** Indicates a hazard that may result in the loss of life or serious injury of the user unless the described instruction is abided by.

**CAUTION** Indicates a hazard that may result in an injury to the user and/or physical damage to the product or other equipment unless the described instruction is abided by.

 **WARNING**

■ To avoid injury, death of personnel, carefully observe and follow the warnings listed below:

### 1. During the measurement of insulation resistance

- A high voltage is generated in the probe during the measurement of insulation resistance. Do not touch the measured object, the EARTH or LINE terminals or the GUARD terminal.

### 2. During the measurement of AC voltage

- There is AC voltage at the GUARD terminal during the measurement of AC voltage. Do not touch the GUARD terminal.

### 3. Immediately after the measurement of insulation resistance

- The probes or measured object may remain highly charged. Do not touch them immediately after measurement.

### 4. Probe

- Use the probe supplied by Yokogawa Meters & Instruments Corporation for the instrument concerned.
- Do not use a deteriorated or damaged probe.
- Do not attach/detach the probe to/from the instrument prior to releasing it from the measured object.

### 5. Protection

- If there are any cracks or other damage in the case because of being dropped or struck, the instrument may not be safely insulated. Do not use the instrument before any remedial measures are taken.

### 6. Object to be measured

- When insulation resistance is measured, turn off the power to the measured object.
- When the instrument is used in a location where an electric current is flowing, never touch the power line.  
Use rubber gloves as a safety precaution.

### 7. Replacement of batteries

- Prior to detaching the cover for replacing the batteries, release the probe from the measured object and turn off the switch.
- Do not touch the measurement switch during replacement. Otherwise, a high voltage may be produced.

### 8. Operating Environment

- Do not operate the instrument in a flammable or explosive gas atmosphere.
- Do not operate the instrument if there is condensation on it.

### 9. Disassembly

- Do not attempt to disassemble the instrument.

 **CAUTION**

■ To avoid injury of personnel or damage to the instrument, carefully observe and follow the cautions listed below.

### 1. Measurement of AC voltage

- Do not apply a voltage over the allowable limits between the terminals.

### 2. GUARD terminal

- The GUARD terminal is an auxiliary measurement terminal to eliminate a leakage current. Do not apply a voltage to the terminal.

### 3. Power supply to the measured object

- Metals and wiring connected to the electric equipment may have a voltage being applied. Confirm that no voltage is being applied prior to connecting the measurement terminal. The same precaution applies to the grounding system.

### 4. Batteries

- Do not use different types of batteries together or new and old batteries together. If the instrument is not used for a long period, store the instrument with the batteries removed. Otherwise, any leakage from the batteries may damage the instrument.

## 1. Component Names

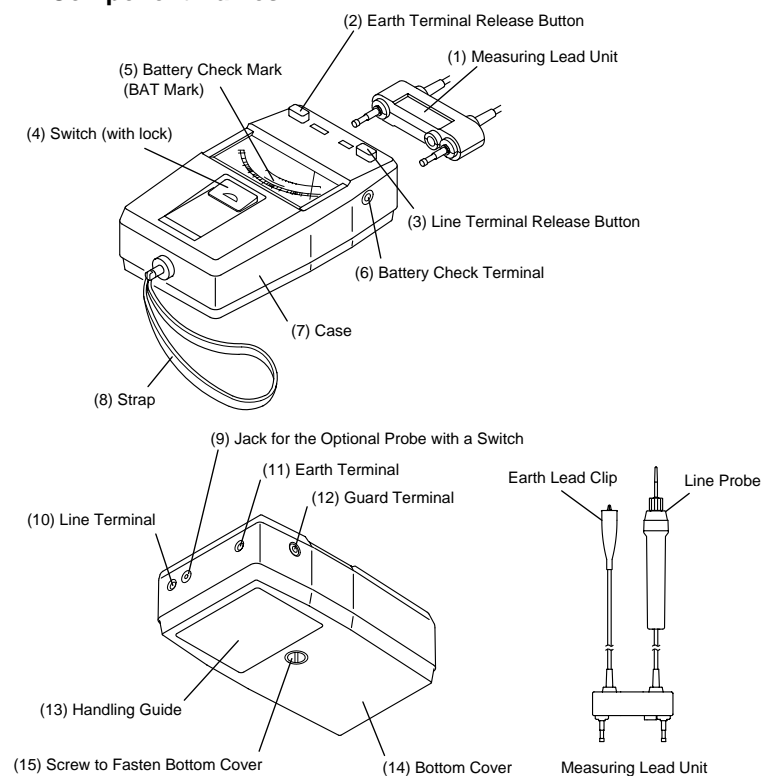

## Outline of Measurement Principle

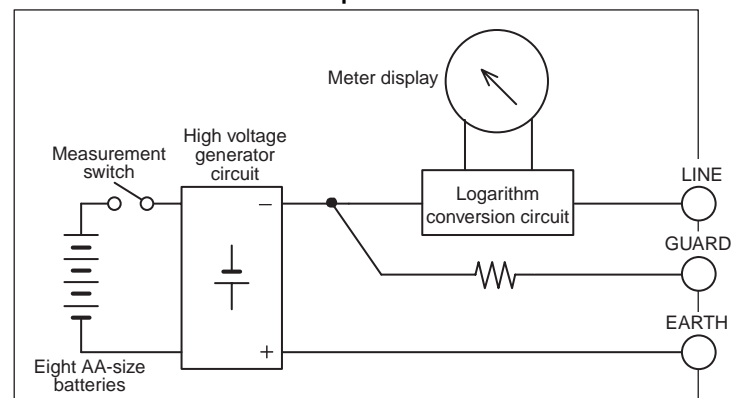

## 2. Measuring Operations

### ● Connecting the Measuring Lead Unit

Connect the measuring lead unit (1) to the tester by inserting its plugs into the line terminal (10) and earth terminal (11). Be sure to insert the plug of the line probe to the line terminal, and the plug of the earth lead clip to the earth terminal. These plugs are locked once they are securely inserted.

### Measurement wiring

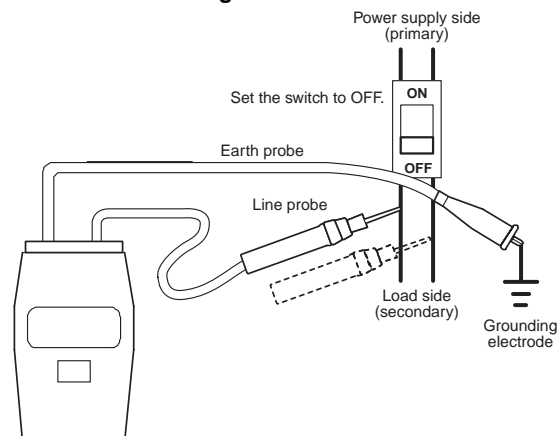

### ● Disconnecting the Measuring Lead Unit

Disconnect the measuring lead unit while pressing the earth terminal and line terminal release buttons (2) and (3) simultaneously.

### ● Measurement of Insulation Resistance

If the object to be measured is earthed, connect the earth lead clip to the earthing point of the object. Apply the line probe of the measuring lead unit (1) to the object to be measured, then press the switch (4). The tester needle indicates the obtained insulation resistance value. When applying the line probe, do not allow its lead wire to come into contact with the earth, floor, or other object. If this happens, insulation resistance cannot be measured correctly. The earth lead clip may be either connected if the object to be measured is not earthed.

### ● Locking the Switch

Pull up the switch (4) to keep it in the 'on' position. This function is useful if measurement is to continue for a long time. If the locked state is prolonged, however, the battery will quickly become depleted.

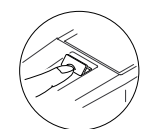

### ● Using the Optional Probe with a Switch

Insert the probe plugs to the line terminal (10), earth terminal (11), and jack (9). To start measurement, press the probe switch instead of the switch (4) on the main unit.

### ● Measurement of Volume Resistance

Volume resistance alone can be measured without any effect of surface leakage resistance. When testing a cable, for example, wrap a bare wire around the insulating material, and connect an optional lead for guard terminal between the bare wire and the guard terminal (12) as shown in the figure on the right. This prevents leakage current on the insulating material from flowing into the tester; thus only volume resistance can be measured correctly. When measuring volume resistance, the optional lead for guard terminal (model: 321803) must be used for connection to the guard terminal.

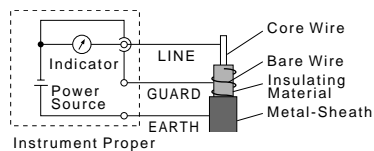

### ! WARNING

Beware of electric shock. There is voltage between the earth and line terminals and between the earth and guard terminals.

### 3. Zero Checking

Connect the line terminal (10) and earth terminal (11) together using the measuring lead unit (1), and press the switch (4). If the tester needle indicates a reading not exceeding the zero scale indication, the tester is considered normal. If it does not, check the batteries following the instructions given in Item 4, "Checking the Batteries." If the batteries have run down, replace them as described in Item 5, "Replacing Batteries," and then perform zero checking again. If the tester needle does not indicate the proper point even though the batteries are still available, the tester requires adjustment. Please contact your nearest Yokogawa.

### 4. Checking the Batteries

- Without pressing the switch, apply the line probe to both poles of the battery check terminal (6) simultaneously as shown in the figure on the right.
- If the tester needle indicates any reading below the battery check mark (BAT) (5) on the scale plate, the batteries can still be used.
- Readings above the battery check mark mean that the batteries have run down. Replace them according to the instructions given in Item 5, "Replacing Batteries."

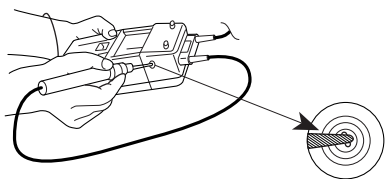

### 5. Replacing Batteries

- Loosen the screw (15) on the bottom cover using a coin or similar, and then remove the bottom cover (14).
- Replace all 8 batteries at the same time. Batteries must be placed oriented according to the indication written on the holder.

### ! CAUTION

A malfunction may occur if a dead battery leaks.

### 6 AC Voltage Measurement

This tester can also measure AC voltages of commercially-available frequencies. Therefore, use this function during the insulation resistance test to confirm that there is no voltage applied to the object to be measured.

- Insert the measuring lead unit (1) to the tester by inserting its plugs into the line terminal (10) and earth terminal (11) in the same manner as when measuring insulation resistance.
- Apply the measuring lead unit to the AC voltage test point, and read the indication on the voltage measuring scale (AC V). Do not press the switch (4) when measuring AC voltages.

### ! WARNING

Do not connect a guard-terminal lead to the guard terminal (12). AC voltage is applied to the guard terminal during AC voltage measurement. This may cause electric shock.

### 7. Maintenance

#### ■ Storage Conditions

- Temperature: -10 to 60°C
- Humidity: 70% RH or less (with batteries removed, no condensation)
- Keep the instrument away from moisture, direct sunlight, heat, vibration, dust, coastal air, and corrosive gases.

#### ■ Cleaning

Clean the instrument with a damp cloth using water or alcohol. Use of a volatile solvent such as a thinner or benzene may cause discoloration.

#### ■ Calibration

Interval between calibrations: One year  
Periodic calibration is required to ensure the accuracy of measurement. Please contact your nearest Yokogawa for calibration.

### 8. Specifications

Specifications for this instrument conform to JIS C1302-2002 (Japanese Industrial Standard).

Model	Rating	First Effective Measuring Range	Second Effective Measuring Range	Central Scale Mark	AC Voltage Measuring Range	Low-limit Measuring Range	Rated Current
321341	100 V/20 MΩ	0.02 to 10 MΩ	10 to 20 MΩ	0.5 MΩ	0 to 150 V	0.1 MΩ	1 mA
321342	250 V/50 MΩ	0.05 to 20 MΩ	20 to 50 MΩ	1 MΩ	0 to 250 V	0.25 MΩ	1 mA
321343	500 V/100 MΩ	0.1 to 50 MΩ	50 to 100 MΩ	2 MΩ	0 to 300 V	0.5 MΩ	1 mA
321344	500 V/1000 MΩ	1 to 500 MΩ	500 to 1000 MΩ	20 MΩ	0 to 300 V	0.5 MΩ	1 mA**
321345	1000 V/2000 MΩ	2 to 1000 MΩ	1000 to 2000 MΩ	50 MΩ	0 to 300 V	1 MΩ	1 mA**

\* : The minimum reading that can maintain the rated voltage.

\*\* : 0.55 mA in the first effective measuring range.

#### Standard Conditions

- Ambient temperature : 23±5°C
- Relative humidity : 45 to 75%RH
- Position : Horizontal (within 5° of the horizontal)
- External magnetic field : None
- Battery voltage : Within the effective battery range (below the battery check mark on the scale plate).

#### Tolerances (under standard conditions)

- Measured resistance : ±5% in the first effective measuring range  
±10% in the second effective measuring range
- Infinity scale and zero scale: Within 0.7% of the scale length
- AC voltage : ±10% of the maximum reading
- Open-circuit voltage : Within 130% of the rated voltage
- Rated measuring current : -0% to +20% of 1 mA in the first effective measuring range
- Short-circuit current : Within 12 mA

Effect of AC component of voltage at measurement terminals: Within 10% of reading when a capacitor of 5 μF ±10% is connected in parallel with a resistor the value of which is determined from the rated measuring voltage and current, and which is itself connected to the measuring terminals.

Response time: Within three seconds to reach the tolerance range after resistances equivalent to the central and zero scale readings are suddenly applied to the tester.

Instantaneous maximum voltage: No more than 1.5-fold the rated measuring voltage.

Effect of temperature: When the ambient temperature is raised to 40°C and lowered to 0°C both from 23°C, variations shall be within 5% of the scale length at the central scale mark, and within 0.7% at the infinity scale and zero scale marks.

Effect of humidity: The specified tolerances shall be met after the tester has been left under the condition of 90% relative humidity for one hour.

Effect of external magnetic field: A change shall be within 10% when the maximum, center, and minimum values of the first effective measuring range are indicated and an external field of 400 A/m DC is applied in the most affected direction.

Effect of inclination: Within 2% of the scale length when tested at the infinity scale mark by inclining the tester 90° forward and backward then to the right and the left from the horizontal.

Effect of external voltage: When an AC voltage 1.2-fold the rated measuring voltage at 50 Hz or 60 Hz is applied between the measuring terminals for 10 seconds with the switch (4) being turned on and then off, there is no abnormality.

Battery voltage: Within the effective battery range (below the battery check mark on the scale plate).

Possible number of measurements: When the measuring time is five seconds each with approximately 25 seconds between measurements, using manganese batteries and the minimum resistance that can be measured while the rated measuring voltage is connected.

Model	Range	Number of measurements
321341	100 V/20 MΩ	Approx. 5,700
321342	250 V/50 MΩ	Approx. 5,300
321343	500 V/100 MΩ	Approx. 3,000
321344	500 V/1000 MΩ	Approx. 3,000
321345	1000 V/2000 MΩ	Approx. 1,000

Withstand voltage: 3700 V AC for one minute between the electric circuits and the outer case.

Scale length: Approximately 84 mm

Protection against water, solid matter, and dust penetration: JIS C0920 compliance, class IP 40: Foreign substances of 1.0 mm or more in diameter must not enter at all.

Vibration proof: When a vibration frequency of 25 Hz and a peak-to-peak amplitude of 1 mm is applied for 20 minutes in each of three directions that are perpendicular to each other, the specifications for tolerances are met.

Shock proof: When a half-sine pulse shock of a 1000 m/s<sup>2</sup> peak acceleration is applied in both forward and reverse for 6 ms, three times in each of three directions—totaling 18 times—specifications for tolerance are met.

Operating temperature/humidity range: 0 to 40°C; within 90%RH (no condensation)

Storage temperature/humidity range: -10 to 60°C; within 70% RH (with batteries removed, no condensation)

External dimensions : Approx. 177×105×55mm

Weight : Approximately 700 g (including batteries)  
Approximately 1.2 kg (including carrying case, strap, measuring lead unit, and batteries)

#### Accessories

Name	Model/Part Number	Quantity	Description
Battery	R6P (AA (SUM-3) or equivalent)	8	Contained in the main unit
(1) Measuring lead unit	B9205VA	1	Equipped with both earth and line leads
(2) Carrying case	B9600HA	1	With a test lead storage bag
(3) Strap	B9303XE	1	
• Instruction manual	IM321341-01E	1	This manual

#### Optional Accessories

Name	Model/Part Number	Description
(4) Probe tip	B9600GN B9600NW B9600NX B9600NZ B9635JK	General-purpose With a hook With extension Pointed Pickax-shaped
(5) Probe tip storage bag	B9600NV	
(6) Probe with a switch	321802	
(7) Lead for guard terminal	321803	

#### Supplies

Name	Part Number	Description
(1) Measuring lead unit	B9205VA	Equipped with both earth and line leads
(2) Carrying case	B9600HA	With a test lead storage bag
• Test lead storage bag	B9646CA	
(3) Strap	B9303XE	

#### Measuring Terminal Voltage Characteristics

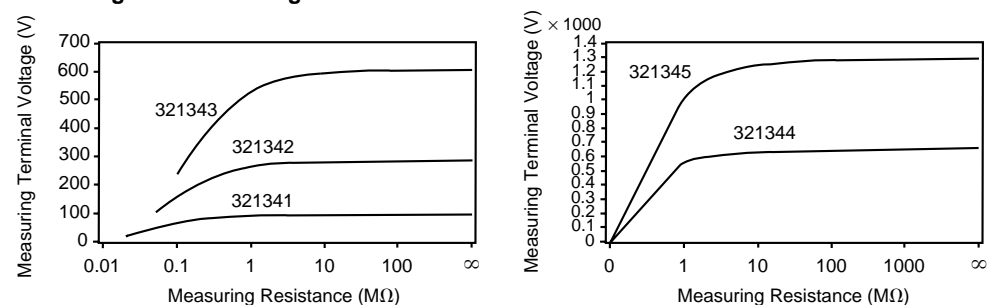

#### External Dimensions

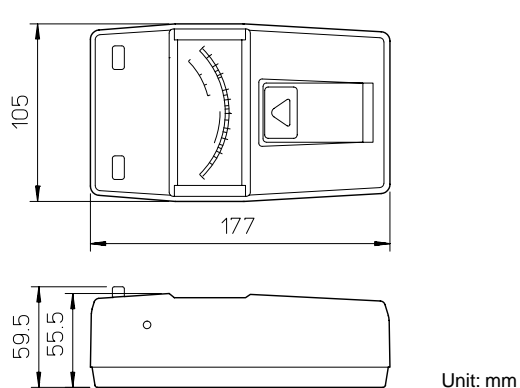

#### ■ Notice Regarding This Instruction Manual

- The contents of this instruction manual are subject to change without prior notice.
- If any questions arise or errors are found, or if any information is missing from this manual, please inform Yokogawa Meters & Instruments.
- Yokogawa Meters & Instruments is by no means liable for damage resulting from the misuse of this product by the user.
- This manual is intended to explain the function of this product. Yokogawa Meters & Instruments does not warrant that the functions will suit a particular purpose of the user.