

## Measuring Concentrations of Developing Solutions and Fluoric Acid

**Industry:** Electrical & Electronics

**Product:** Inductive conductivity analyzers

### Introduction

In a semiconductor plant, a variety of chemicals are used in various manufacturing processes. The chemicals used for specific purposes are produced by diluting raw liquid with demineralized water using in diluting equipment, and the control of the concentration at this point is performed by conductivity measurement. The ISC202 and ISC402 Inductive Conductivity Analyzer are capable of high-precision measurement, and their toroidal probe ISC40 is sealed in rugged PEEK (Poly Ether Ether Ketone) material to withstand the harshest applications. A highly reliable measurement is achieved by using ISC202/ISC450 in the control of concentrations of chemicals in a dilution system. The

ISC202 and ISC450G Inductive Conductivity Analyzer also play a role in the drainage control and the processing of solutions delivered from various manufacturing processes.

### Expected Benefits

- Easy control of fluoric acid concentration
- Reduces operating costs
- Establishment of corrosion-resistant wetted parts

### Process Overview

Up to now, chemicals used in semiconductor plants have been purchased in concentrations diluted beforehand by the chemical company to suit specific applications. However, as the price competition in the semiconductor market is increased, the operating cost reduction is highly required. As a result, each chemical used in a manufacturing process has been reviewed so that the substance profits and widespread cost reductions are secured.

Ordering chemicals in various concentrations from chemical manufacturing companies has been replaced by the installation of dilution systems at individual companies, whereby a raw chemical solution, whose price is not significantly different from that of diluted chemicals, is diluted to the required concentration, using inexpensive demineralized water.

### Dilution System Configuration

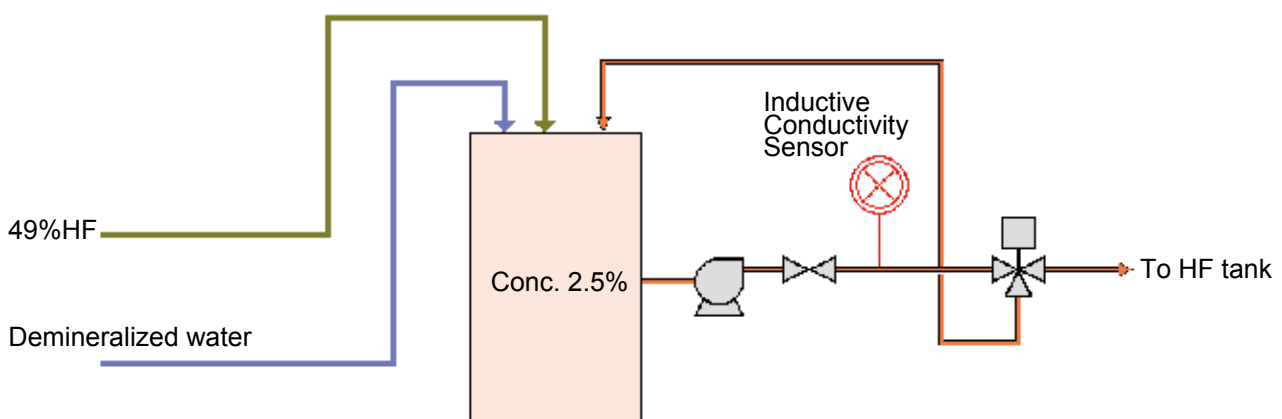

Controlled to room temperature  $\pm 5^{\circ}\text{C}$

## Solution Details

### Measurement system

#### 2-wire inductive conductivity system

Sensor

ISC40G(J)-GG-T1-□□/Z Z: Teflon coating

Flow-through type holder

ISC40FF(J)-PJ/Z Z: Teflon coating

Transmitter

ISC202G-A-E

Dedicated distributor for transmitter

PH201G-A□\*B

#### 4-wire inductive conductivity system

Sensor

ISC40G(J)-GG-T1-□□/Z Z: Teflon coating

Flow-through type holder

ISC40FF(J)-PJ/Z Z: Teflon coating

Converter

ISC450G-A-□

## Utilities

#### ISC202G inductive conductivity transmitter

Power supply voltage: 17 – 40 V DC (from distributor)

Power consumption: 0.9 VA maximum

#### PH201G distributor

Power supply: 100 V: 20 to 130 V DC / 80 to 138 V AC, 47 to 63 Hz  
220 V: 120 to 340 V DC / 138 to 264 V AC, 47 to 63 Hz

Power consumption: 24 V DC: approx. 200 mA  
100 V AC: approx. 7 VA  
220 V AC: approx. 11 VA

#### ISC450G inductive conductivity converter

Power supply: 90 to 264 V AC, 50/60 Hz

Power consumption: 15 VA maximum

## Field Data

### Measurement Examples

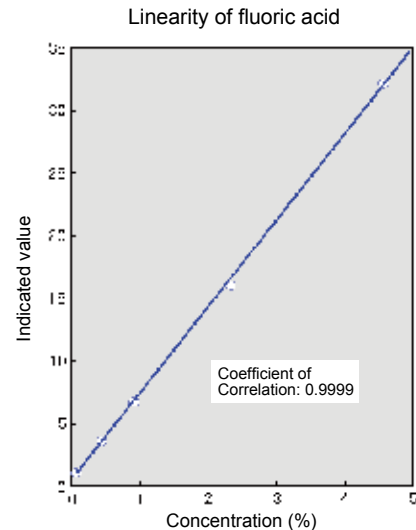

Relationship of Electric Conductivity and Concentration in Semiconductor Developing Solution

