

Maintaining High Quality in Soda Electrolysis by Measuring and Controlling Liquid Density

Industry: Chemical

Product: Liquid Density Meter

Introduction

Caustic soda (sodium hydroxide) is an important basic material in the chemical industry and is mainly produced by the electrolysis of soda. There are two types of electrolysis processes: the diaphragm method and the ion-exchange membrane method; the latter is becoming mainstream because of its lower energy consumption and higher product quality. Both methods involve evaporating the solution after the electrolysis process to make concentrated caustic soda. This process is where the concentration is measured. Using the fact that there is a nearly linear relationship between the liquid density and the concentration, the concentration can be determined by measuring the liquid density.

Process Overview

The solid salt is dissolved in water and impurities in the salt are removed. The purified solution is fed to an electrolyzer, where the solution is electrolyzed to produce caustic soda and chlorine. The concentration of the caustic soda solution produced at the cathode in the electrolyzer is approximately 32%. The solution is concentrated in a multiple effect evaporator to a product level of approximately 48%.

In the ion-exchange membrane method, one density meter is installed before the evaporator to control the steam temperature and pressure of the evaporator so that the concentration of the caustic soda is kept constant. Another density meter is installed after the evaporator for the purpose of controlling the product quality.

The DM8 Vibration Type Liquid Density Meter has high sensitivity and stability and can be used to ensure highly accurate control.

Expected Benefits

- Ensures high product quality through stable and accurate measurement of liquid density
- Reduces operating costs

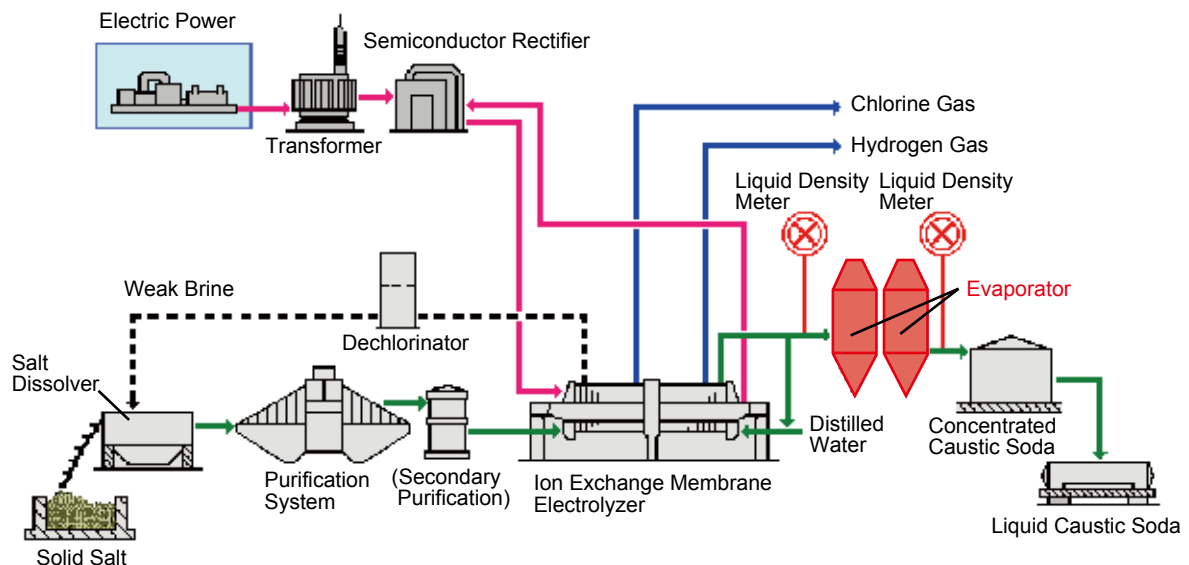

Solution Details

Measurement System

Detector: VD6D-N1*B
 Converter: DM8C-A□*B
 Dedicated cable: DM8W-L□□□□*A
 Sampling system:
 VD6SM- □□□ -P□□0-T□□0*B/FN
 (provided by customer in some cases)

Utilities

DM8C converter/VD6D detector:
 Power supply (to converter): 90 to 132/180 to 264 V AC, 50/60 Hz
 Power consumption: 20 VA

Field Data

1. Process conditions

Measurement point	Before evaporator	After evaporator
Temperature	70 to 80°C	150 to 170°C
NaOH concentration	20 to 35%	40 to 48%
Density	1.25 to 1.35 g/cm ³	1.4 to 1.5 g/cm ³

Notes

- In order to prevent corrosion, be sure to use a nickel vibrator assembly for measurement of caustic soda density.
- Literature data of the concentration and density characteristics of caustic soda are mostly based on a NaOH solute only. The characteristics may change if the solution contains solutes other than NaOH. For the conversion of density to concentration, make a calibration curve by using the actual sample.
- Air bubbles in a sample solution may interfere with accurate measurement. Take appropriate measures to remove them, if necessary.
- Measured liquid temp. should be cooled down less than 100°C, because after evaporator temp. may be more than 100°C.

<Example of removal of air bubbles>

Conditions

Temperature at inlet: 0 to 100°C
 Pressure at inlet: 0 to 2 MPa
 Flow range: 1 to 10 l/min
 Differential pressure between inlet and outlet: 100 kPa or more

DM8C Converter



VD6D Detector



Feature

- The vibration density measurement principle allows high accuracy and resolution.
- The structure is maintenance free.
- The detector is more compact compared to other manufactures'.

2. Relationship between concentration and density of caustic soda

(Source: International Critical Table)

