

## pH Measurement of Wastewater Treatment at Pulp and Paper Plants

**Industry:** Pulp and paper  
**Product:** pH/ORP Analyzer

### Introduction

Pulp and paper plants consume large volumes of water, and the treatment of wastewater from these plants is a serious environmental concern. To treat this wastewater, suspended solids (SS) are separated and precipitated in a precipitation tank using flocculation agents. During this process, the pH value needs to be maintained at the proper level, the status of which is controlled by referring to a pH analyzer. In the past, pH analyzers needed to be cleaned frequently as fibers and coating agents in the wastewater adhered to the electrodes.

We tested a submersion-type holder with an ultrasonic+air-jet cleaner to determine its effectiveness in the continuous cleaning of pH analyzers. Manual maintenance of pH analyzers used

to be conducted on a daily basis, but our test results have demonstrated that this submersion type holder can reduce the manual cleaning frequency to just once every one or two months.

### Expected Benefits

- Continuously and stably measures pH
- Eliminates the need for frequent manual cleaning
- Enables efficient use of flocculating agents

### Process Overview

Wastewater at pulp and paper plants contains effluents from the pulping, bleaching, papermaking, and recycling processes. The treatment of this wastewater involves pH level control, solid-liquid separation, oxidization, and other processes, and depends on such factors as the levels of organic, reducible and suspended matter in the wastewater as well as its chromaticity. For example, most SS are fine substances that do not precipitate easily, so they are removed by applying flocculating agents, which produce a chemical reaction. To detect the end points of these chemical reactions and to manage and control the precipitation tank, the pH of the wastewater tank is measured.

### Management and control of the precipitation tank by measuring the pH of the wastewater tank

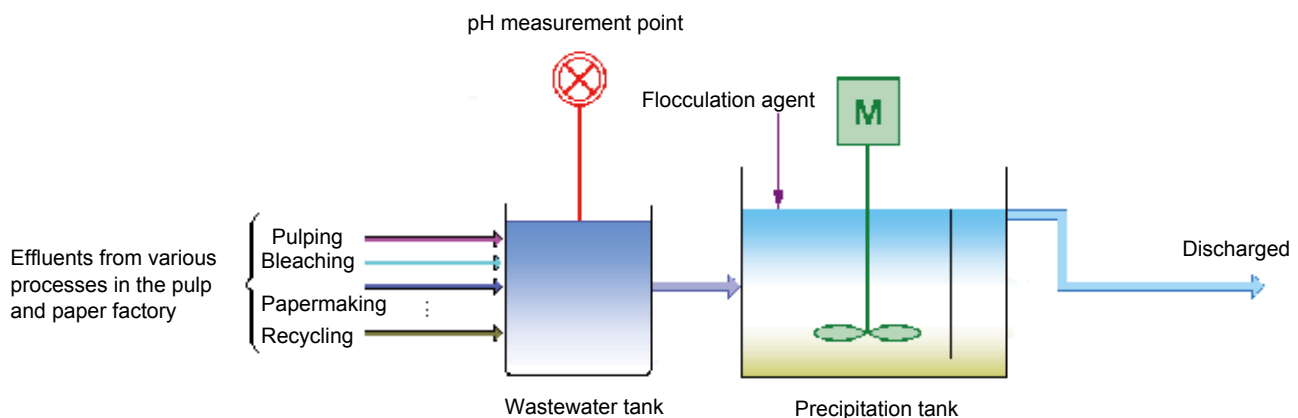

## Solution Details

### Measurement system

#### 4-wire pH measurement system (with ultrasonic+air-jet cleaner)

##### pH sensor

KCl filling type pH sensor

PH8EFP-□□-TN-TT1-N-G\*A

##### Holder

Submersion holder with an ultrasonic+air-jet cleaner  
(customized product)

PH8HS-PP-□□-T-S3-C□\*A/Z

(Z: option for air bubble nozzle)

##### Terminal box (when needed)

WTB10-PH3

##### Converter

PH450G-A-□

##### Ultrasonic oscillator

PUS400G-NN-NN-□-E

### Utilities

#### PH450G

Power supply: 90 to 264 V AC, 50/60 Hz

Power consumption: pproximately 15 VA

#### PUS400G Ultrasonic Oscillator

Power supply: 100/110/115/200/220/240 V AC  $\pm$  10%,  
50/60 Hz

Power consumption: approximately 15 VA

#### PH8HS/Z

Air for bubbling: 10 to 50 NI/min.

### Conditions

#### 1. Effectiveness of previous cleaning methods

Cleaning methods using a standard jet cleaner and a brush were tested. Fibers in the effluents that had attached to the electrode could not be removed using either of these cleaning methods. (Both types of cleaning operations also had to be suspended once a day to conduct manual cleaning of the electrode.)

#### 2. Effects of continuous cleaning using an ultrasonic+air-jet cleaner

The amount of the contaminants on the electrode decreased significantly. Manual cleaning and calibration were found to be required just once every one or two months.

#### Test Data from Continuous Cleaning Using an Ultrasonic+Air-jet Cleaner

| Operation period | Drift value                       |                                   |
|------------------|-----------------------------------|-----------------------------------|
|                  | Standard pH7 solution measurement | Standard pH4 solution measurement |
| 1 month          | -0.19 pH                          | -0.25 pH                          |
| 2 months         | -0.20 pH                          | -0.20 pH                          |

Note: During the test, no manual electrode cleaning and calibration were performed.

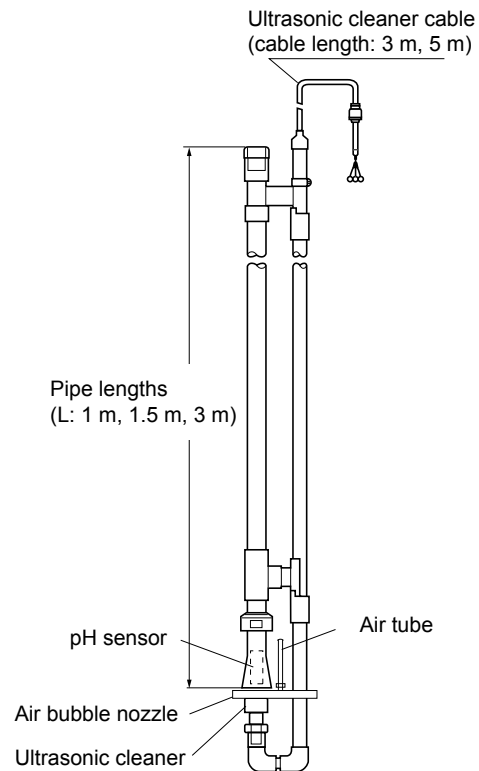

#### Submersion holder with an ultrasonic+air-jet cleaner (customized product)

### Notes

Testing conducted on the effects of pH analyzer cleaning only addressed effluents from the papermaking process. However, this submersion holder can also be used to keep pH analyzers clean that measure effluents from the recycling process, which has fibers, printing ink substances, and coating agents.