

Zone Furnace Temperature (for Manufacture of Graphite Electrodes)

Industry: Machinery (Heat Treatment)
Product: Control and Measurement Station (CX2000)
Digital Indicating Controller (UT450)

Overview

In the graphite electrode manufacturing process, the ratio of the impurities to be combined differs depending on the type of carbon used for the electrodes, and therefore a wide variety of furnace temperature control profiles (recipes) must be available. With the CX2000, up to thirty patterns can be managed internally, but if more recipes are needed they can be stored on a PC, and the appropriate ones for the types of electrode being manufactured can be downloaded to the CX. These recipes undergo analog retransmission to a temperature controller (the UT450) as setpoints, and each temperature zone is controlled based on the resultant profile. The zone control status is transmitted via serial communications from the UT450 for monitoring and recording on the CX.

Customer Needs

- To replace the old style recipe generator, monitoring/recording chart recorders, and indicating controllers used for recipe management as inexpensively as possible
- To be able to easily connect to existing SCADA systems that control our current production lines, and to be offered open solutions for efficient data exchange.
- Tools that make it easy for operators to manage a large variety of recipes without mistakes.
- To achieve low cost usage for the future by electronically recording the control process, saving results as quality data, and reducing maintenance man-hours of the spare parts.

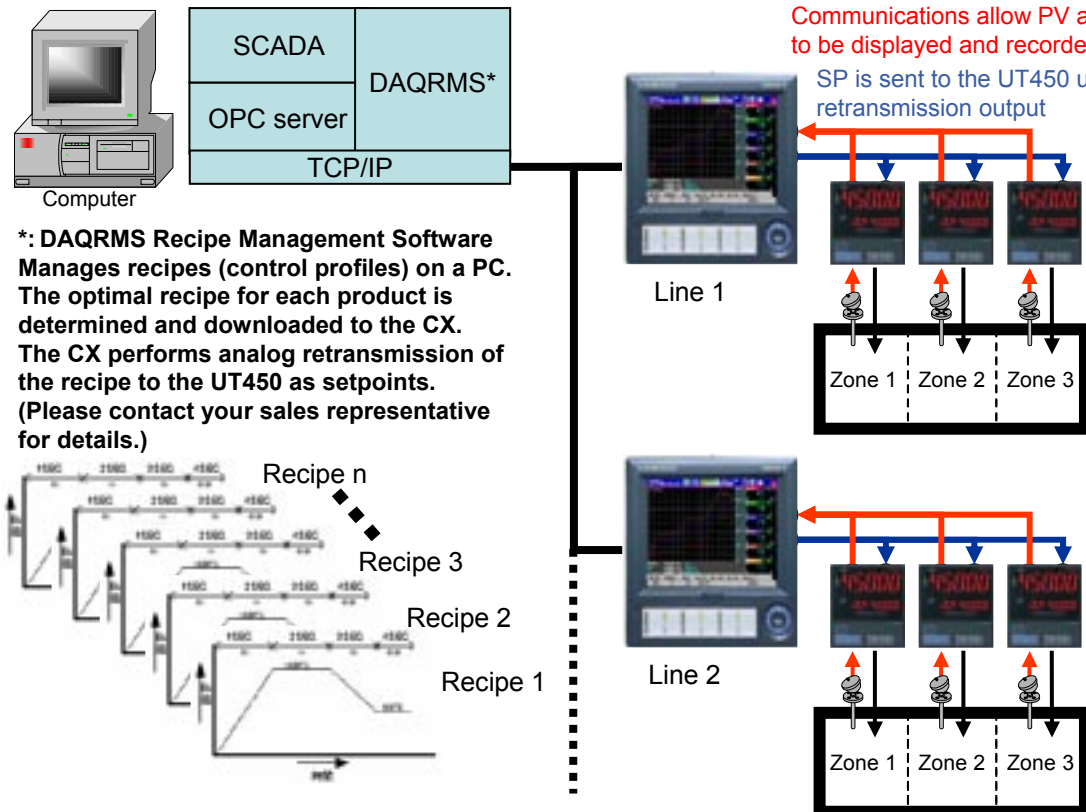

*: DAQRMS Recipe Management Software Manages recipes (control profiles) on a PC. The optimal recipe for each product is determined and downloaded to the CX. The CX performs analog retransmission of the recipe to the UT450 as setpoints. (Please contact your sales representative for details.)

Process Outline

In the graphite electrode manufacturing process, a wide spectrum of furnace temperature control profiles (recipes) are required to correspond with the various types of carbon used as the material for the electrodes. The CX2000 can handle up to thirty recipes internally and can support running of recipes for many types of products. But if more than thirty recipes need to be managed, DAQRMS (recipe management software developed for the CX) can be used for centralized processing of a wide variety of recipes on a PC.

Recipes created in advance for each product are handled together on DAQRMS and downloaded to the CX2000 accordingly. The recipes downloaded to the CX undergo analog retransmission to a temperature controller (the TU450) as setpoints, and each temperature zone is controlled based on that profile. The conditions of each of the zones, which are controlled by local temperature controllers, are sent from the UT450 to the CX2000 via serial communications for real time alarm monitoring and digital recording by the CX2000. By using the CX2000, the ideal temperature profile recipe currently being executed can be simultaneously monitored on the large display and recorded with the actual running conditions that are being transmission-input from the local temperature controllers. Thus chart recorders and indicating controllers can be replaced by a single CX2000, leading also to increased running quality.

The CX2000 performs analog retransmission of the recipes downloaded from the PC to the local indicating controllers, thereby replacing old style recipe generator functions. Also, recipe information and local running data gathered in the CX2000 are sent to SCADA via OPC server, and data from multiple furnaces can be monitored and managed together on an upstream SCADA system. By replacing the various types of instruments with a single CX2000, you minimize rework on the panel and lower the cost of equipment upgrades.

Yokogawa's Solution



The CX2000 Measurement & Control System is capable of managing recipes for a variety of equipment

CX2000

- 288 mm x 288 mm panel cut dimensions, with recipe management functions for up to 30 patterns
- Connect up to 16 local temperature controllers allowing centralized monitoring. Also enables sending of SP to local controllers.
- PV, SP, OUT, and other running data also simultaneously monitored and digitally recorded (CF card)
- Max. 26-point paperless recording function (6 points of control + 20 points for measurement)
- Web monitor, FTP, e-mail, and other networking functions come standard

DAQRMS Recipe Management Software

Software for managing recipes (control profiles) on a PC. Recalls the optimal recipe for each product for download to the CX. (Please contact your sales representative for details.)

Conclusion

Yokogawa offers the combination of the CX2000 and recipe management software, making it easy for an operator to manage a highly diverse array of recipes. It is an application in which a variety of models on the same line are run by switching control conditions, and it contributes to increased quality and operating efficiency. Also, you can digitally record the control process, and by sending the data upstream using OPC server software and the internal networking functions of the CX2000, you can centrally manage the information on upstream SCADA or other systems. The CX2000 offers a simple and high cost-performing solution.