



# The IT M@chine Controller



## Overview (1)



- FA Link (H) Module [ F3LP01-0N→F3LP02-0N ]
  - Upward compatible
- FL-net Interface Module [F3LX01-0N→F3LX02-1N]
  - FL-net (OPCN-2)Ver.1.0 is replaced with FL-net (OPCN-2) Ver.2.00.
  - Programming-wise upward compatible
  - Communication protocols differ so requires replacement of all connected devices.
- Ladder Communication Module [F3RZ81-0N→F3RZ81-0F]
  - Functionally compatible but requires program modification.
- Ladder Communication Module [F3RZ91-0N→F3RZ91-0F]
  - Functionally compatible but requires program modification.

## Overview (2)



- Positioning Module [F3YP04/08-0N→F3YP14/18-0N]
  - Upward compatible but requires program modification because of different relay/register configurations.
- Positioning Module [F3NC95-0N→F3NC96-0N]
  - MECHATROLINK communication interface is replaced with MECHATROLINK- II communication interface.
  - Upward compatible but requires replacement of connectors and cables.
- Ethernet Interface Module [F3LE01-5T→F3LE01-0T]
  - 100% application compatible but with no AUI interface.

## FA Link (H) Module F3LP01-0N→F3LP02-0N (1)



### ■ Comparison of Specifications

#### □ Upward compatible

Item	F3LP01-0N	F3LP02-0N
Number of connected stations	32 stations per system	32 stations per system
Link relays	Up to 1024 points per module F3SP08/21: 2048 F3SP28/53: 8192 F3SP38/58/59: 16384	Up to 2048 points per module F3SP08/21: 2048 F3SP28/53: 8192 F3SP38/58/59: 16384
Link registers	Up to 1024 points per module F3SP08/21: 2048 F3SP28/53: 8192 F3SP38/58/59: 16384	Up to 2048 points per module F3SP08/21: 2048 F3SP28/53: 8192 F3SP38/58/59: 16384
Maximum link points per station	Same as above	Same as above
Link relay/register assignments	Link relays: on 16-point basis Link registers: on 1-point basis	Link relays: on 16-point basis Link registers: on 1-point basis
Number of attached modules	F3SP08/21: 2 max F3SP28/38/53/58/59: 8 max	F3SP08/21: 2 max F3SP28/38/53/58/59: 8 max
Transmission rate	250kbps	125k/250k/625k/1.25Mbps (by switch setup)
Topology	Single bus	Single bus
Terminating resistors	110 Ω internal resistor on each end (selectable by hardware switch)	110 Ω internal resistor on each end (selectable by hardware switch)
Transmission distance	500 m max.	1km/500m/200m/100m (depending on transmission rate)
Communication mode	Token bus	Token bus
Synchronization mode	Frame synchronization	Frame synchronization
Transmission format	HDL compliant	HDL compliant
Symbolization mode	NRZI mode	NRZI mode
Error control	CRC-CCITT	CRC-CCITT, timeout detection
RAS function	- Local loop-back function - Hardware self-diagnosis - Error detection by special relays and registers	- Local loop-back function - Hardware self-diagnosis - Error detection by special relays and registers
Transmission media	Shielded twist-pair cable (AWG20)	Shielded twist-pair cable (AWG20)

## FA Link (H) Module F3LP01-0N→F3LP02-0N (2)



### ■ Programming precautions

#### □ Upward compatible

#### ■ When connecting F3LP02-0N and F3LP01-0N:

- Set the baud rate of F3LP02-0N to 250kbps using hardware switch.
- Calculate the response time using formulae for F3LP01-0N.

## FL-net Interface Module F3LX01-0N→F3LX02-1N (1)



### ■ Comparison of Specifications

#### □ Upward compatible

Item	F3LX01-0N	F3LX02-1N
Number of connected nodes	254 max.	254 max.
Cyclic transmission	512 words in area 1	512 words in area 1
	8192 words in area 2	8192 words in area 2
Message transmission	1024 bytes max.	1024 bytes max.
Number of installed modules	2 max. (modules cannot be installed in a sub-unit)	2 max. (modules cannot be installed in a sub-unit)
Transmission rate	10Mbps	10Mbps
Topology	Bus	Bus
Transmission distance	500m max. (2.5 km when using repeaters)	500m max. (2.5 km when using repeaters)
Transmission media	Compliant to IEEE802.3	Compliant to IEEE802.3
External power supply	12V DC (when power is supplied via AUI port)	12V DC (when power is supplied via AUI port)
Fuse	2A time lag fuse (not replaceable as it is embedded in the power supply terminal)	2A time lag fuse (not replaceable as it is embedded in the power supply terminal)
Current consumption	580 mA max.	<b>460 mA max.</b>
External dimensions	28.9 (W) x 100 (H) x 83.2 (D) mm	28.9 (W) x 100 (H) x 83.2 (D) mm
	(excluding protrusions)	(excluding protrusions)
Weight	160 g	<b>130 g</b>

## FL-net Interface Module F3LX01-0N→F3LX02-1N (2)



### ■ Programming Precautions

#### □ Upward compatible

### ■ Connected hardware devices

- All devices connected on the same network must be replaced with FL-net(OPCN-2)Ver.2.00 compatible devices. (Intermixing FL-net(OPCN-2)Ver.1.00 and Ver 2.00 compatible devices is not allowed)

### ■ Setup Precautions

- When using a hub employing auto-negotiation, set element 4 of the Condition Setup switch (4-pole DIP switch) located on the side of the F3LX02-1N module inside the module cover to ON to select the 10BASE-T communication port.

# Ladder Communication Module F3RZ81-0N→F3RZ81-0F (1)



## ■ Comparison of Specifications

Item		F3RZ81-0N	F3RZ81-0F
Connection method		Point to point	Point to point
Transmission mode		Full-duplex/half-duplex	Full-duplex/half-duplex
Synchronization		Start-stop synchronization	Start-stop synchronization
Communication protocol		No protocol	No protocol
Data format	Character length	7 or 8 bits	7 or 8 bits
	Stop bit length	1, 1.5 or 2 bits	<b>1 or 2 bits</b>
	Parity bit	None, even or odd	None, even or odd
Transmission rate		75, 150, 300, 600, 1200, 2400, 4800, 9600, 19200 bps	<b>300, 600, 1200, 2400, 4800, 9600, 14400, 19200, 28800, 38400, 57600, 76800, or 115200 bps</b>
Control lines	RS control	1: Always on. 2: Turn on before sending.	1: Always on. 2: Turn on before sending.
	DR check	1: Ignore DR when sending. 2: Send only when DR is on.	1: Ignore DR when sending. 2: Send only when DR is on.
	CD check	1: Ignore CD when sending. 2: Send only when CD is off.	1: Ignore CD when sending. 2: Send only when CD is off.
	ER control	1: On (ready) 2: Off (not ready)	1: On (ready) 2: Off (not ready)
Communication buffers	Send buffer	Text buffer (598 bytes max.)	<b>Text buffer (3584 bytes max.)</b>
	Receive buffer	2048-byte rotary buffer	<b>8192-byte rotary buffer</b>
Format of received text	Start character	- Yes or No - Any single character	- Yes or No - Any single character
	End character (terminator)	- Yes or No - Up to 2 characters long, any characters	- Yes or No - Up to 2 characters long, any characters
	Text length	Can be specified as any number between 1 and 596	<b>Can be specified as any number between 1 and 3584</b>
	Character-to-character timeout interval	0 to 32760 ms in 1 ms increments, accurate to 1 ms (0 means not monitored)	0 to 32760 ms in 1 ms increments, accurate to 1 ms (0 means not monitored)
Clear-to-send timeout interval		0 to 32760 ms in 1 ms increments, accurate to 1 ms (0 means not monitored)	0 to 32760 ms in 1 ms increments, accurate to 1 ms (0 means not monitored)
Break transmission interval		No	<b>1 to 32760 ms in 1 ms increments, accurate to 1 ms</b>
Xon/Xoff control		Yes	<b>No</b>
Transmission distance		15 m max.	15 m max.
Number of ports		1 (not isolated)	1 (not isolated)
Current consumption		100 mA	<b>320 mA</b>
Weight		120 g	120 g

# Ladder Communication Module F3RZ81-0N→F3RZ81-0F (2)



## ■ Functional Differences

### □ Removal of Commands

- In F3RZ81-0N, a command register and a setup relay is used for communication setup and buffer initialization; In F3RZ81-0F, separate relays are provided for individual functions so no command register setup is required.
- F3RZ81-0F does not provide a port reset function.

### □ Reading Communication Settings

- In F3RZ81-0N, the current communication settings are always reflected in the register area; In F3RZ81-0F, the current settings are reflected in the status area only when a user turns on the Read Communication Mode Status output relay.

### □ Xon/Xoff Control

- Xon/Xoff control is not available in F3RZ81-0F.

### □ Break Signal

- F3RZ81-0F supports sending and receiving of the Break signal.

# Ladder Communication Module F3RZ81-0N→F3RZ81-0F (3)



## □ Error Handling

- In F3RZ81-0N, a program detects an error by reading the Response Status register after confirming that the “End-of-xx” relay has turned on. In F3RZ81-0F, separate error relays are provided.

## □ Sending

- In F3RZ81-0N, a program sets the data size and the transmission data in the output registers and turns on the Start-of-Sending relay. The module then sends the specified number of bytes, starting from the byte following the data size. In F3RZ81-0F, a program writes the data size to the Send Data Byte Count register, stores the transmission data to the Send Data Area and turns on the Request to Send relay. The module then sends the specified number of bytes, starting from the first byte of the Send Data Area.

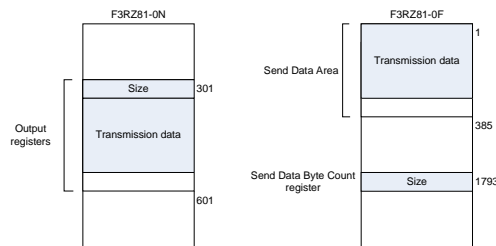

# Ladder Communication Module F3RZ81-0N→F3RZ81-0F (4)



## □ Receiving

- In F3RZ81-0N, the receive status and the size of received data are stored in the Receive Area. In F3RZ81-0F only the received data is stored in the receive area while the status and data size are stored in separate dedicated registers.

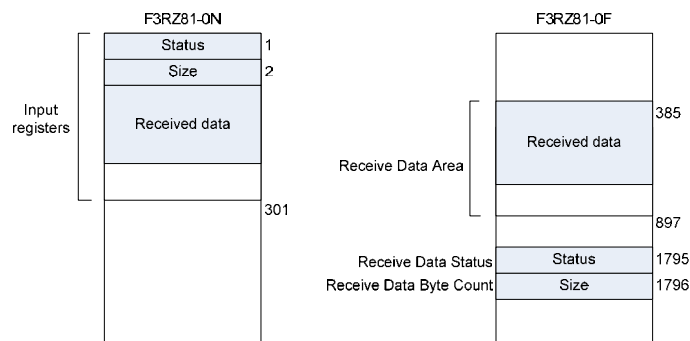

## Ladder Communication Module F3RZ81-0N→F3RZ81-0F (5)



### ■ Input Relays

- F3RZ81-0F has additional input relays, namely, Read Communications Mode Status Completed relay, Initialize Receive Buffer Completed relay, Send Break Completed relay, Receive Error relay, Send Error relay and Set Communications Mode Error relay.

Input Relays of F3RZ81-0N

X□□□01	End-of-Receiving
X□□□02	End-of-Sending
X□□□03	End-of-Setting
X□□□04 to X□□□32	Reserved

Input Relays of F3RZ81-0F

X□□□01	Receive Completed
X□□□02	Send Completed
X□□□03	Set Communications Mode Completed
X□□□04	Read Communications Mode Status Completed
X□□□05	Initialize Receive Buffer Completed
X□□□06	Send Break Completed
X□□□07	Receive Error
X□□□08	Send Error
X□□□09	Set Communications Mode Error
X□□□10 to X□□□32	Reserved

## Ladder Communication Module F3RZ81-0N→F3RZ81-0F (6)



### ■ Output Relays

- F3RZ81-0F has additional output relays, namely, Request to Read Communications Mode Status relay, Request to Initialize Receive Buffer relay and Request to Send Break relay.

Output Relays of F3RZ81-0N

Y□□□33	End-of-Reading
Y□□□34	Start-of-Sending
Y□□□35	Start-of-Setting
Y□□□36 to Y□□□64	Reserved

Output Relays of F3RZ81-0F

Y□□□33	Read Received Data Completed
Y□□□34	Request to Send
Y□□□35	Request to Set Communications Mode
Y□□□36	Request to Read Communications Mode Status
Y□□□37	Request to Initialize Receive Buffer
Y□□□38	Request to Send Break
Y□□□39 to Y□□□64	Reserved

### ■ Programming Precautions

- See sample program at the end of the presentation.

## Ladder Communication Module F3RZ91-0N→F3RZ91-0F (1)



### ■ Comparison of Specifications

Item		F3RZ91-0N	F3RZ91-0F
Connection method		Point to point	Point to point
Transmission mode		Full-duplex/half-duplex	Full-duplex/half-duplex
Synchronization		Start-stop synchronization	Start-stop synchronization
Communication protocol		No protocol	No protocol
Data format	Character length	7 or 8 bits	7 or 8 bits
	Stop bit length	1, 1.5 or 2 bits	1 or 2 bits
	Parity bit	None, even, or odd	None, even, or odd
Transmission rate		75, 150, 300, 600, 1200, 2400, 4800, 9600, 19200 bps	<b>300, 600, 1200, 2400, 4800, 9600, 14400, 19200, 28800, 38400, 57600, 76800, or 115200 bps</b>
Transmission media		Shielded twisted pair cable (AWG20-16)	Shielded twisted pair cable (AWG20-16)
Communication buffers	Send buffer	Text buffer (598 bytes max.)	<b>Text buffer (1792 bytes max.)</b>
	Receive buffer	2048-byte rotary buffer	<b>8192-byte rotary buffer</b>
Format of received text	Start character	- Yes or no - Any single character	- Yes or no - Any single character
	End character (terminator)	- Yes or no - Up to 2 characters long, any characters	- Yes or no - Up to 2 characters long, any characters
	Text length	1 to 596 characters	<b>1 to 1792 characters</b>
	Character-to-character timeout interval	Yes or no	Yes or no
Break signal transmission		No	<b>Yes</b>
Xon/Xoff control		Yes	<b>No</b>
Transmission distance		1200 max.	1200 max.
Number of ports		1 (isolated)	1 (isolated)
Current consumption		210 mA	<b>350 mA</b>
Weight		140 g	<b>120 g</b>

TI 34M06Z41-01E

13

## Ladder Communication Module F3RZ91-0N→F3RZ91-0F (2)



### ■ Functional Differences

#### □ Removal of Commands

- In F3RZ91-0N, a command register and a setup relay is used for communication setup and buffer initialization; In F3RZ91-0F, separate relays are provided for individual functions so no command register setup is required.
- F3RZ91-0F does not provide a port reset function.

#### □ Reading Communication Settings

- In F3RZ91-0N, the current communication settings are always reflected in the register area; In F3RZ91-0F, the current settings are reflected in the status area only when a user turns on the Read Communication Mode Status output relay.

#### □ Xon/Xoff Control

- Xon/Xoff control is not available in F3RZ91-0F.

#### □ Break Signal

- F3RZ91-0F supports sending and receiving of the Break signal.

TI 34M06Z41-01E

14

# Ladder Communication Module F3RZ91-0N→F3RZ91-0F (3)



## □ Error Handling

- In F3RZ91-0N, a program detects an error by reading the Response Status register after confirming that the “End-of-xx” relay has turned on. In F3RZ91-0F, individual error relays are provided.

## □ Sending

- In F3RZ91-0N, a program sets the data size and the transmission data in the output registers and turns on the Start-of-Sending relay. The module then sends the specified number of bytes, starting from the byte following the data size. In F3RZ91-0F, a program writes the data size to the Send Data Byte Count register, stores the transmission data to the Send Data Area and turns on the Request to Send relay. The module then sends the specified number of bytes, starting from the first byte of the Send Data Area.

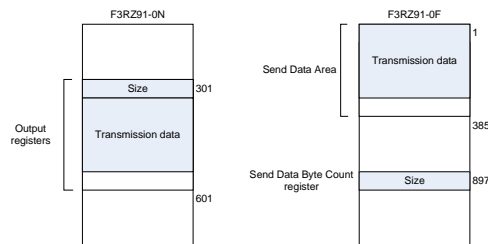

# Ladder Communication Module F3RZ91-0N→F3RZ91-0F (4)



## □ Receiving

- In F3RZ91-0N, the receive status and the size of received data are stored in the Receive Area. In F3RZ91-0F only the received data is stored in the receive area while the status and data size are stored in separate dedicated registers.

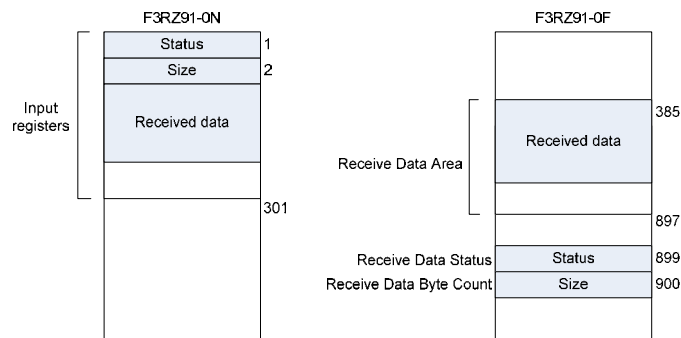

## Ladder Communication Module F3RZ91-0N→F3RZ91-0F (5)



### ■ Input Relays

- F3RZ91-0F has additional input relays, namely, Read Communications Mode Status Completed relay, Initialize Receive Buffer Completed relay, Send Break Completed relay, Receive Error relay, Send Error relay and Set Communications Mode Error relay.

Input Relays of F3RZ91-0N

X□□□01	End-of-Receiving
X□□□02	End-of-Sending
X□□□03	End-of-Setting
X□□□04 to X□□□32	Reserved

Input Relays of F3RZ91-0F

X□□□01	Receive Completed
X□□□02	Send Completed
X□□□03	Set Communications Mode Completed
X□□□04	Read Communications Mode Status Completed
X□□□05	Initialize Receive Buffer Completed
X□□□06	Send Break Completed
X□□□07	Receive Error
X□□□08	Send Error
X□□□09	Set Communications Mode Error
X□□□10 to X□□□32	Reserved

## Ladder Communication Module F3RZ91-0N→F3RZ91-0F (6)



### ■ Output Relays

- F3RZ91-0F has additional output relays, namely, Request to Read Communications Mode Status relay, Request to Initialize Receive Buffer relay and Request to Send Break relay.

Output Relays of F3RZ91-0N

Y□□□33	End-of-Reading
Y□□□34	Start-of-Sending
Y□□□35	Start-of-Setting
Y□□□36 to Y□□□64	Reserved

Output Relays of F3RZ91-0F

Y□□□33	Read Received Data Completed
Y□□□34	Request to Send
Y□□□35	Request to Set Communications Mode
Y□□□36	Request to Read Communications Mode Status
Y□□□37	Request to Initialize Receive Buffer
Y□□□38	Request to Send Break
Y□□□39 to Y□□□64	Reserved

### ■ Programming Precautions

- See sample program at the end of the presentation.

# Positioning Module

## F3YP04/08-0N→F3YP14/18-0N (1)



### ■ Comparison of Specifications

- **Bold underlined parts are added in F3YP14/18-0N.**
- Same external connector pin assignments so the same cable can be used.
- Same module access method (e.g. command execution) but requires program modification due to different I/O relay, parameter and status data configurations.
- F3YP14/18-0N is not yet certified for CE marking.

Model no.	F3YP04-0N	F3YP08-0N	F3YP14-0N	F3YP18-0N
Number of controlled axes	4	8	4	8
Control	Control mode	Open loop control using pulse output	Open loop control using pulse output	Open loop control using pulse output
	Output pulse	Line driver output (CW/CCW)	Line driver output (CW/CCW, pulse/direction)	Line driver output (CW/CCW, pulse/direction) Rotation direction selection
Positioning functions	Control unit	Pulse	Pulse	Pulse
	Control mode	PTP control	PTP control	PTP control
	Interpolation	Multi-axis linear interpolation	Multi-axis linear interpolation	Multi-axis linear interpolation
	Operation	Direct operation	Direct operation	Direct operation
Position reference	Mode	Incremental or absolute	Incremental or absolute	Incremental or absolute
	Data	-134,217,728 to +134,217,727 pulses	<b>-2,147,483,647 to +2,147,483,647 pulses</b>	<b>-2,147,483,647 to +2,147,483,647 pulses</b>
Speed reference	Mode	Trapezoidal	Trapezoidal, <b>S-shaped</b>	Trapezoidal, <b>S-shaped</b>
	Data	0 to 32,767ms	0 to 32,767ms	0 to 32,767ms
ACC/DCC	Mode	Trapezoidal	Trapezoidal, <b>S-shaped</b>	Trapezoidal, <b>S-shaped</b>
Origin search		Any	<b>Automatic origin search (2 types), any</b>	<b>Automatic origin search (2 types), any</b>
Others		Software limits Change current position	Software limits, Change current position, <b>Speed limit function,</b> Change speed, ACC/DCC time during movement, <b>Change target position during movement</b>	Software limits, Change current position, <b>Speed limit function,</b> Change speed, ACC/DCC time during movement, <b>Change target position during movement</b>
	External contact I/O	Origin, Z-phase Forward/reverse limit inputs Deviation pulse clear	Origin, Z-phase Forward/reverse limit inputs Deviation pulse clear	Origin, Z-phase Forward/reverse limit inputs Deviation pulse clear
External power supply		DC 5V	DC 5V	DC 5V
Startup time		6 ms max.	0.09 ms for 1 axis 0.25 ms for 4 axes 0.5 ms for 8 axes (Up to 1 ms delay if other axes are moving)	0.09 ms for 1 axis 0.25 ms for 4 axes 0.5 ms for 8 axes (Up to 1 ms delay if other axes are moving)
	Backup		No	Flash ROM

# Positioning Module

## F3YP04/08-0N→F3YP14/18-0N (2)



### ■ Output Relays

- As I/O refreshing is carried out on 16-relay basis, attention is paid to data concurrency between axes in F3YP14/18-0N and the I/O relays have been rearranged.

F3YP04/08-0N Output Relays

Y00033	AX1 Execute Command	Y00049	AX5 Execute Command
Y00034	AX1 Stop Immediately	Y00050	AX5 Stop Immediately
Y00035	AX1 Forward Jog	Y00051	AX5 Forward Jog
Y00036	AX1 Reverse Jog	Y00052	AX5 Reverse Jog
Y00037	AX2 Execute Command	Y00053	AX6 Execute Command
Y00038	AX2 Stop Immediately	Y00054	AX6 Stop Immediately
Y00039	AX2 Forward Jog	Y00055	AX6 Forward Jog
Y00040	AX2 Reverse Jog	Y00056	AX6 Reverse Jog
Y00041	AX3 Execute Command	Y00057	AX7 Execute Command
Y00042	AX3 Stop Immediately	Y00058	AX7 Stop Immediately
Y00043	AX3 Forward Jog	Y00059	AX7 Forward Jog
Y00044	AX3 Reverse Jog	Y00060	AX7 Reverse Jog
Y00045	AX4 Execute Command	Y00061	AX8 Execute Command
Y00046	AX4 Stop Immediately	Y00062	AX8 Stop Immediately
Y00047	AX4 Forward Jog	Y00063	AX8 Forward Jog
Y00048	AX4 Reverse Jog	Y00064	AX8 Reverse Jog

F3YP14/18-0N Output Relays

Y00033	AX1 Execute Command	Y00049	AX1 Forward Jog
Y00034	AX2 Execute Command	Y00050	AX2 Forward Jog
Y00035	AX3 Execute Command	Y00051	AX3 Forward Jog
Y00036	AX4 Execute Command	Y00052	AX4 Forward Jog
Y00037	AX5 Execute Command	Y00053	AX5 Forward Jog
Y00038	AX6 Execute Command	Y00054	AX6 Forward Jog
Y00039	AX7 Execute Command	Y00055	AX7 Forward Jog
Y00040	AX8 Execute Command	Y00056	AX8 Forward Jog
Y00041	AX1 Stop Immediately	Y00057	AX1 Reverse Jog
Y00042	AX2 Stop Immediately	Y00058	AX2 Reverse Jog
Y00043	AX3 Stop Immediately	Y00059	AX3 Reverse Jog
Y00044	AX4 Stop Immediately	Y00060	AX4 Reverse Jog
Y00045	AX5 Stop Immediately	Y00061	AX5 Reverse Jog
Y00046	AX6 Stop Immediately	Y00062	AX6 Reverse Jog
Y00047	AX7 Stop Immediately	Y00063	AX7 Reverse Jog
Y00048	AX8 Stop Immediately	Y00064	AX8 Reverse Jog

# Positioning Module

## F3YP04/08-0N→F3YP14/18-0N (3)



### ■ Input Relays

- In F3YP14/18-0N, input relays have been rearranged to match the output relays.

F3YP04/08-0N Input Relays

X□□□01	AX1 Execute Command ACK	X□□□17	AX5 Execute Command ACK
X□□□02	AX1 Stop Immediately ACK	X□□□18	AX5 Stop Immediately ACK
X□□□03	AX1 Error Notification	X□□□19	AX5 Error Notification
X□□□04	AX1 End of Positioning	X□□□20	AX5 End of Positioning
X□□□05	AX2 Execute Command ACK	X□□□21	AX6 Execute Command ACK
X□□□06	AX2 Stop Immediately ACK	X□□□22	AX6 Stop Immediately ACK
X□□□07	AX2 Error Notification	X□□□23	AX6 Error Notification
X□□□08	AX2 End of Positioning	X□□□24	AX6 End of Positioning
X□□□09	AX3 Execute Command ACK	X□□□25	AX7 Execute Command ACK
X□□□10	AX3 Stop Immediately ACK	X□□□26	AX7 Stop Immediately ACK
X□□□11	AX3 Error Notification	X□□□27	AX7 Error Notification
X□□□12	AX3 End of Positioning	X□□□28	AX7 End of Positioning
X□□□13	AX4 Execute Command ACK	X□□□29	AX8 Execute Command ACK
X□□□14	AX4 Stop Immediately ACK	X□□□30	AX8 Stop Immediately ACK
X□□□15	AX4 Error Notification	X□□□31	AX8 Error Notification
X□□□16	AX4 End of Positioning	X□□□32	AX8 End of Positioning

F3YP01/18-0N Input Relays

X□□□01	AX1 Execute Command ACK	X□□□17	AX1 Error Notification
X□□□02	AX2 Execute Command ACK	X□□□18	AX2 Error Notification
X□□□03	AX3 Execute Command ACK	X□□□19	AX3 Error Notification
X□□□04	AX4 Execute Command ACK	X□□□20	AX4 Error Notification
X□□□05	AX5 Execute Command ACK	X□□□21	AX5 Error Notification
X□□□06	AX6 Execute Command ACK	X□□□22	AX6 Error Notification
X□□□07	AX7 Execute Command ACK	X□□□23	AX7 Error Notification
X□□□08	AX8 Execute Command ACK	X□□□24	AX8 Error Notification
X□□□09	AX1 Stop Immediately ACK	X□□□25	AX1 End of Positioning
X□□□10	AX2 Stop Immediately ACK	X□□□26	AX2 End of Positioning
X□□□11	AX3 Stop Immediately ACK	X□□□27	AX3 End of Positioning
X□□□12	AX4 Stop Immediately ACK	X□□□28	AX4 End of Positioning
X□□□13	AX5 Stop Immediately ACK	X□□□29	AX5 End of Positioning
X□□□14	AX6 Stop Immediately ACK	X□□□30	AX6 End of Positioning
X□□□15	AX7 Stop Immediately ACK	X□□□31	AX7 End of Positioning
X□□□16	AX8 Stop Immediately ACK	X□□□32	AX8 End of Positioning

# Positioning Module

## F3YP04/08-0N→F3YP14/18-0N (4)



### ■ Parameters & Statuses

F3YP04/08-0N Registered Parameters

Data Position No.	Parameter
*01	Contact Input Polarity
*02/*03	Forward Limit
*04/*05	Reverse Limit

F3YP14/18-0N Registered Parameters

Data Position No.	Parameter
*01	Maximum Speed Selection
*02	Pulse Output Mode
*03	Direction of Rotation
*04	Contact Input Polarity
*05/*06	Forward Limit
*07/*08	Reverse Limit
*09/*10	Speed Limit
*11	Automatic Origin Search Mode
*12	Automatic Origin Search Direction
*13/*14	Automatic Origin Search Speed 1
*15/*16	Automatic Origin Search Speed 2
*17/*18	Automatic Origin Search Startup Speed
*19	Automatic Origin Search Acceleration Time
*20	Automatic Origin Search deceleration Time
*21	Automatic Origin Search Z-phase Edge Selection
*22	Automatic Origin Search Z-phase Search Count
*23/*24	Automatic Origin Search Z-phase Search Range
*25	Automatic Origin Search Deviation Pulse Clear Time
*26/*27	Automatic Origin Search Origin Offset Value

F3YP04/08-0N Command Parameters

Data Position No.	Parameter
*11	Command Code
*12	Target Position Mode
*13/*14	Target Position
*15/*16	Target Speed
*17	Acceleration Time
*18	Deceleration Time
*19/*20	Startup Speed
*21	Origin Search Mode
*22	Origin Search Direction
*23	Z-phase Edge Selection
*24	Z-phase Search Count
*25/*26	Z-phase Search Range
*27	Deviation Pulse Clear Time

F3YP04/08-0N Statuses

Data Position No.	Status
*51/*52	Target Position Status
*53/*54	Current Position Status
*55/*56	Current Speed Status
*57	Contact Input Status
*58	Error Status
*59	Origin Search Status

F3YP14/18-0N Command Parameters

Data Position No.	Parameter
*41	Command Code
*42	Target Position Mode
*43/*44	Target Position
*45	Acceleration/deceleration Mode
*46/*47	Target Speed
*48	Acceleration Time
*49	Deceleration Time
*50/*51	Startup Speed
*52	Origin Search Mode
*53	Origin Search Direction
*54	Z-phase Edge Selection
*55	Z-phase Search Count
*56/*57	Z-phase Search Range
*58	Deviation Pulse Clear Time

F3YP14/18-0N Statuses

Data Position No.	Status
*81/*82	Target Position Status
*83/*84	Current Position Status
*85/*86	Current Speed Status
*87	Contact Input Status
*88	Error Status
*89	Alarm Status
*90	Origin Search Status
*91	Extended Status
*92/*93	Number of Flash Memory Write Operations

## Positioning Module F3NC95-0N→F3NC96-0N (1)



### ■ Comparison of Specifications

- Beware that different connectors and cables are used for MECHATROLINK and MECHATROLINK-II communications.
- Required changes when using drivers or motors from Yasukawa Electric:
  - If using  $\Sigma$ III (SGDS), device can be switched to MECHATROLINK II using driver setup.
  - If using  $\Sigma$ II (SGDH), MECHATROLINK-I/F module NS100 must be changed to NS115.
  - If using  $\Sigma$ (SGD-N/SGDB-AN), all devices must be changed to support MECHATROLINK-II.

Item		F3NC95-0N	F3NC96-0N
Interface		MECHATROLINK compliant	MECHATROLINK-II compliant
Transmission rate		4 Mbps	10 Mbps
Transmission bytes		16 bytes	32 bytes
Cycle time versus No. of stations		2.0 ms for up to 15 axes (fixed)	1.0 ms for up to 8 axes, 2.0 ms for up to 15 axes (user selectable)
Network Topology		Bus (multi-drop)	Bus (multi-drop)
Transmission media		2-wire shielded twisted pair cable (MECHATROLINK dedicated cable)	2-wire shielded twisted pair cable (MECHATROLINK-II dedicated cable)
Maximum transmission distance		50 m (total length)	50 m (total length)
Minimum distance between stations		--	0.5 m
Positioning functions	Position reference	-2, 147, 483, 648 to 2, 147, 483, 647 (reference unit)	-2, 147, 483, 648 to 2, 147, 483, 647 (reference unit)
	Functions	- Independent axis movement using MECHATROLINK commands (dependant on connected external equipment and supported MECHATROLINK commands)	- Linear interpolation movement (starting and stopping multiples axes simultaneously) - Independent axis movement using MECHATROLINK-II commands (dependant on connected external equipment and supported MECHATROLINK-II commands)
Number of installed modules		8 modules max. (120 axes max.)	8 modules max. (120 axes max.)
Current consumption		420 mA (5V DC)	570 mA (5V DC)
External connection		One MECHATROLINK communication connector	One MECHATROLINK-II communication connector
Weight		100 g	120 g

## Positioning Module F3NC95-0N→F3NC96-0N (2)



### ■ Programming Precautions

- Upward compatible
- Additional communication parameters
  - "C2 Master" (data position No. 46) is added and must be specified as "connected" or "unconnected".
  - "Communication Cycle Time" (data position No. 49) is added and must be specified as 1 ms (selectable only when 8 or less axes are connected) or 2 ms.
- Additional monitored information
  - Monitored data obtained per communication is increased from two (monitored data 1 to 2) to four (monitored data 1 to 4).
  - However, monitored data 1 (data position No. 83/84) is fixed as "POS" and Monitor 1 Selection (data position No. 11) cannot be specified in F3NC96-0N.
  - If the F3NC95-0N module was previously used with Monitor 1 Selection specified as a value other than "POS", you can make the same selection in the F3NC96-0N module using Monitor 2, 3 or 4 Selection.
- Changes to alarm code
  - This is in accordance with the specifications of MECHATROLINK communication.
  - The Alarm Code value for normal status has been changed from "\$0099" to "\$0099 or \$0000".
  - Exercise care when determining whether status is normal by only reading the alarm code.

# Ethernet Interface Module F3LE01-5T→F3LE01-0T (1)



## ■ Wiring Precautions

- AUI interface removed.
- If AUI connection is required, use a commercial 10BASE-T to 10BASE5 adapter. (See next page for tested third-party adaptors.)

Item	Specifications		
	F3LE01-5T		F3LE01-0T
Model	10BASE-T	10BASE5	10BASE-T
Compatible standard	10BASE-T	10BASE5	10BASE-T
Access Control	CSMA/CD		
Transmission Speed	10 Mbps		
Transmission Method	Baseband		
Maximum Segment Length	100 m	500 m (2.5 km when using repeater)	100 m
Largest Connection Configuration	2 nodes per segment	100 nodes per segment	2 nodes per segment
Protocol	TCP/IP, UDP/IP, ICMP, ARP		
Data Format	Binary or ASCII (for monitoring only)		
Write Protection	Enabled or disabled (for monitoring only)		
Number of Modules that can be Mounted	Total number of modules with similar functions (personal computer link module, FL-net interface module, etc.): 2 max. for F3SP05, F3SP08, F3SP21 6 max. for F3SP25, F3SP28, F3SP35, F3SP38, F3SP53, F3SP58, F3SP59, F3SP66 and F3SP67		
External Power Supply	Not required	12V DC 500 mA	Not required
Current Consumption	330 mA		500 mA
External Dimensions	28.9 (W) X 100 (H) X 83.2 (D) mm		
Weight	130 g		

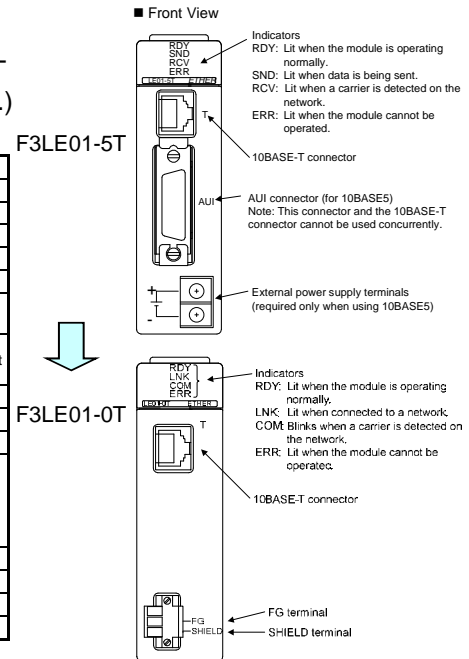

# Ethernet Interface Module F3LE01-5T→F3LE01-0T (2)



## ■ Third-party adapters tested for connection to F3LE01-0T AUI connector for 10BASE5 communication

### □ Black Box Network Services (Black Box Corporation)

Universal Mini Media Converter LE1510A-R2

- Power supply: AC 95 - 125V (50/60Hz)
- Power transformer: 12 VDC, 500 mA to 1 A (for 10BASE5 network power supply)
- Size: 69(W) × 42(D) × 19(H) mm (2.7"W × 1.7"D × 0.8"H)
- Weight: 115 g (0.25 lb) for main unit; 2285 g (5 lb) for power transformer



### □ Allied Telesis, Inc.

8-port Hub (with BNC/AUI) (CenterCOM MR820TRX)

- Power supply: AC100 - 240V (50/60Hz) 0.3A
- Size: 210(W) × 107(D) × 38(H) mm (8.3"W × 4.2"D × 1.5"H)
- Weight: 680 g (1.5 lb)

Note: 10BASE5 network power supply available



\*1: Check the specifications and user manuals published by the respective manufacturer for usage conditions, etc.

\*2: Contact the respective manufacturer directly for enquiry and purchase.

# Comparing Sample Programs for F3RZ81-0N & F3RZ81-0F

## 1. Communication Setup

### ● F3RZ81-0N

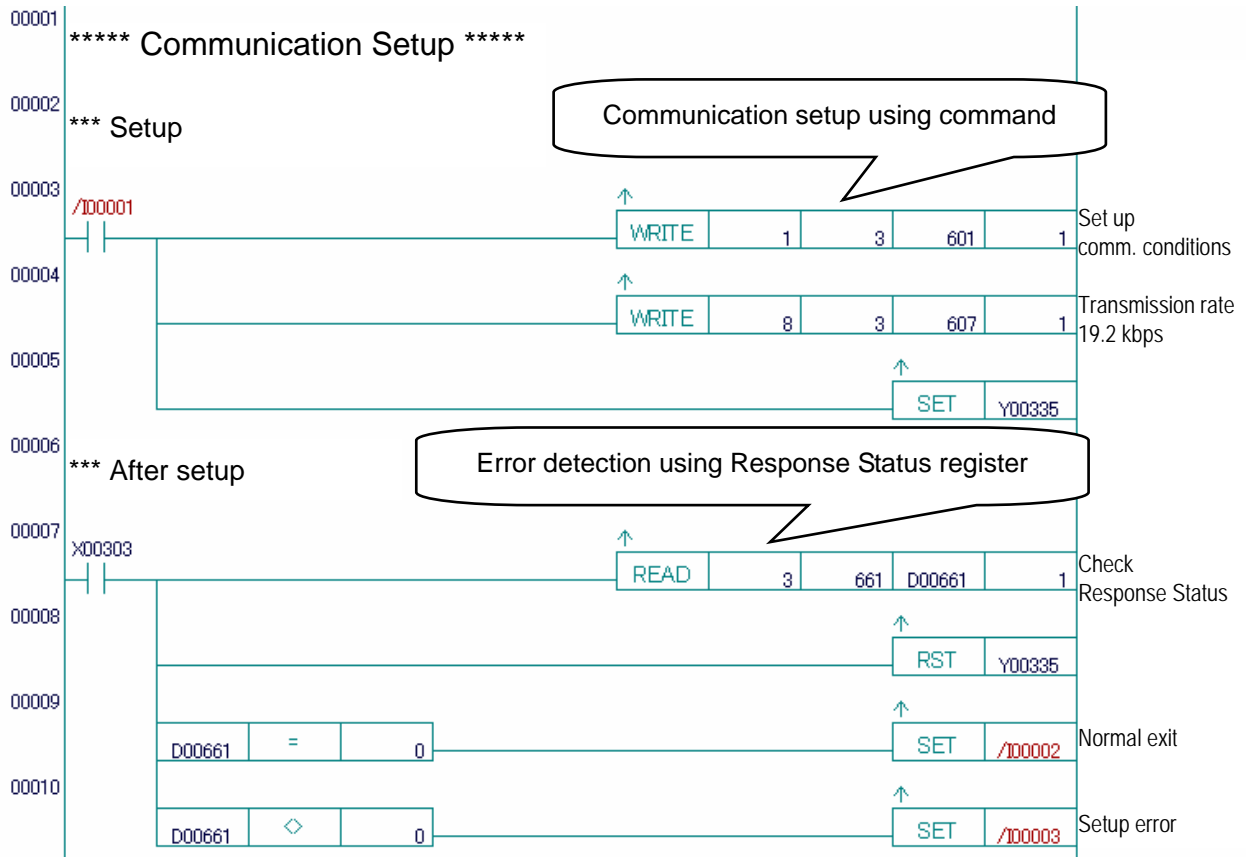

### ● F3RZ81-0F

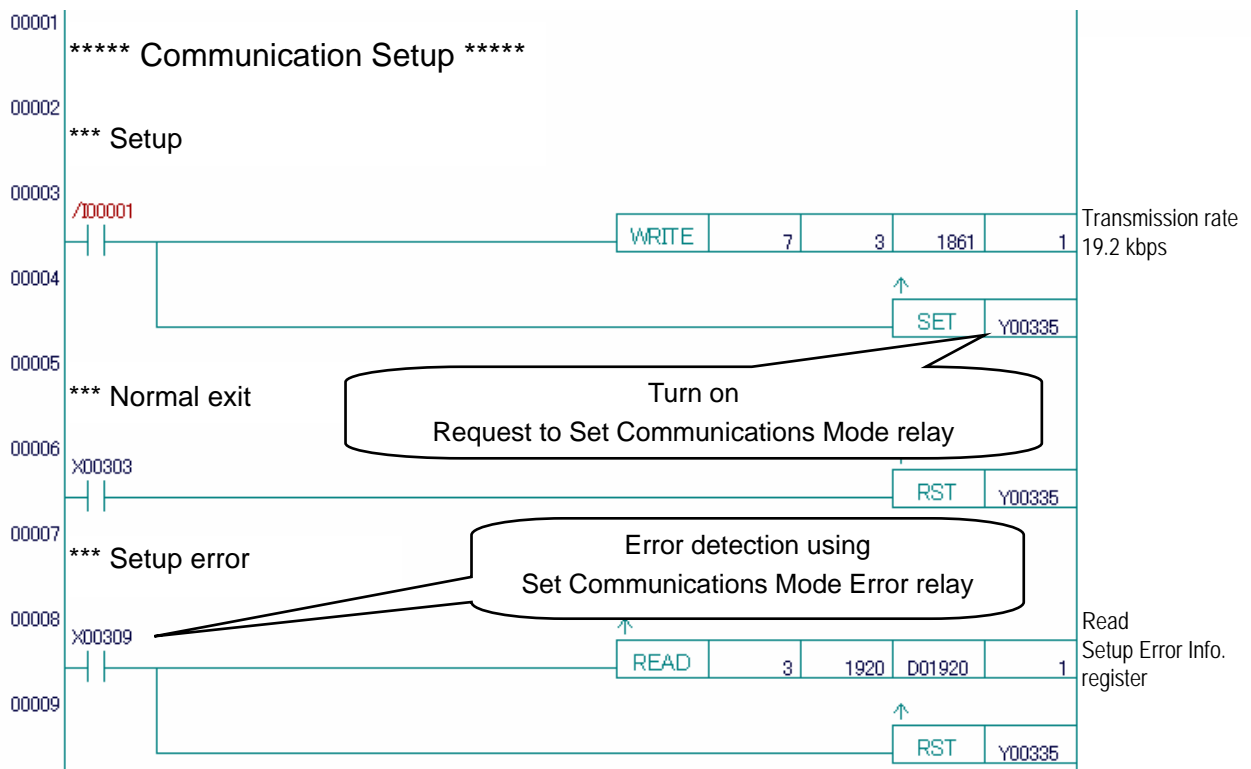

## 2. Reading Communication Settings

### ● F3RZ81-0N

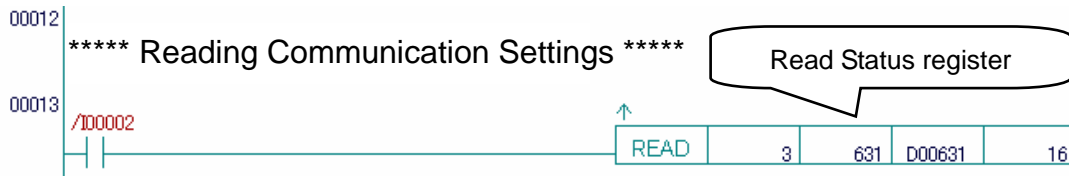

### ● F3RZ81-0F

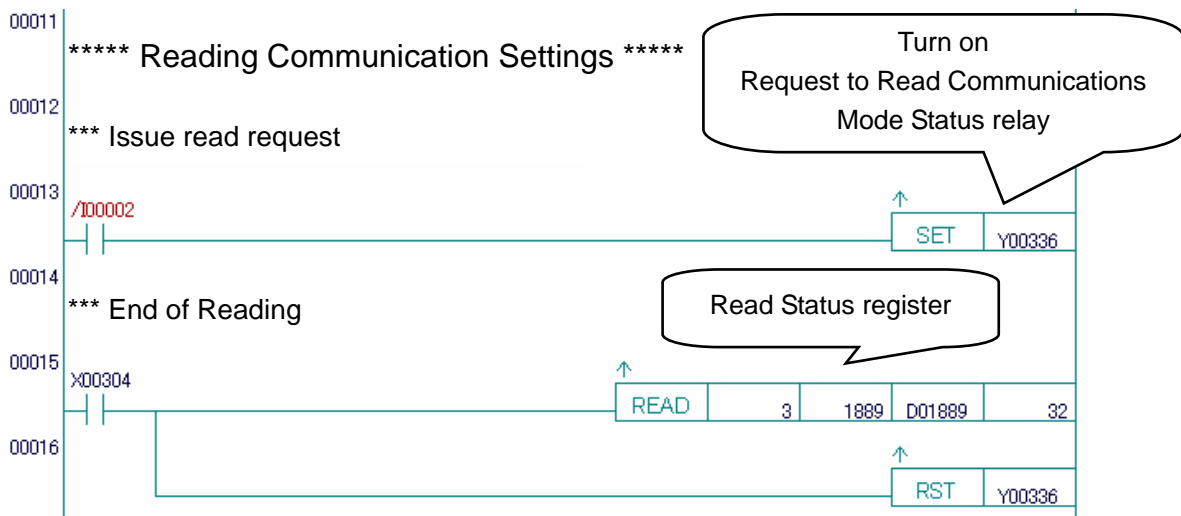

### 3. Sending

● F3RZ81-0N

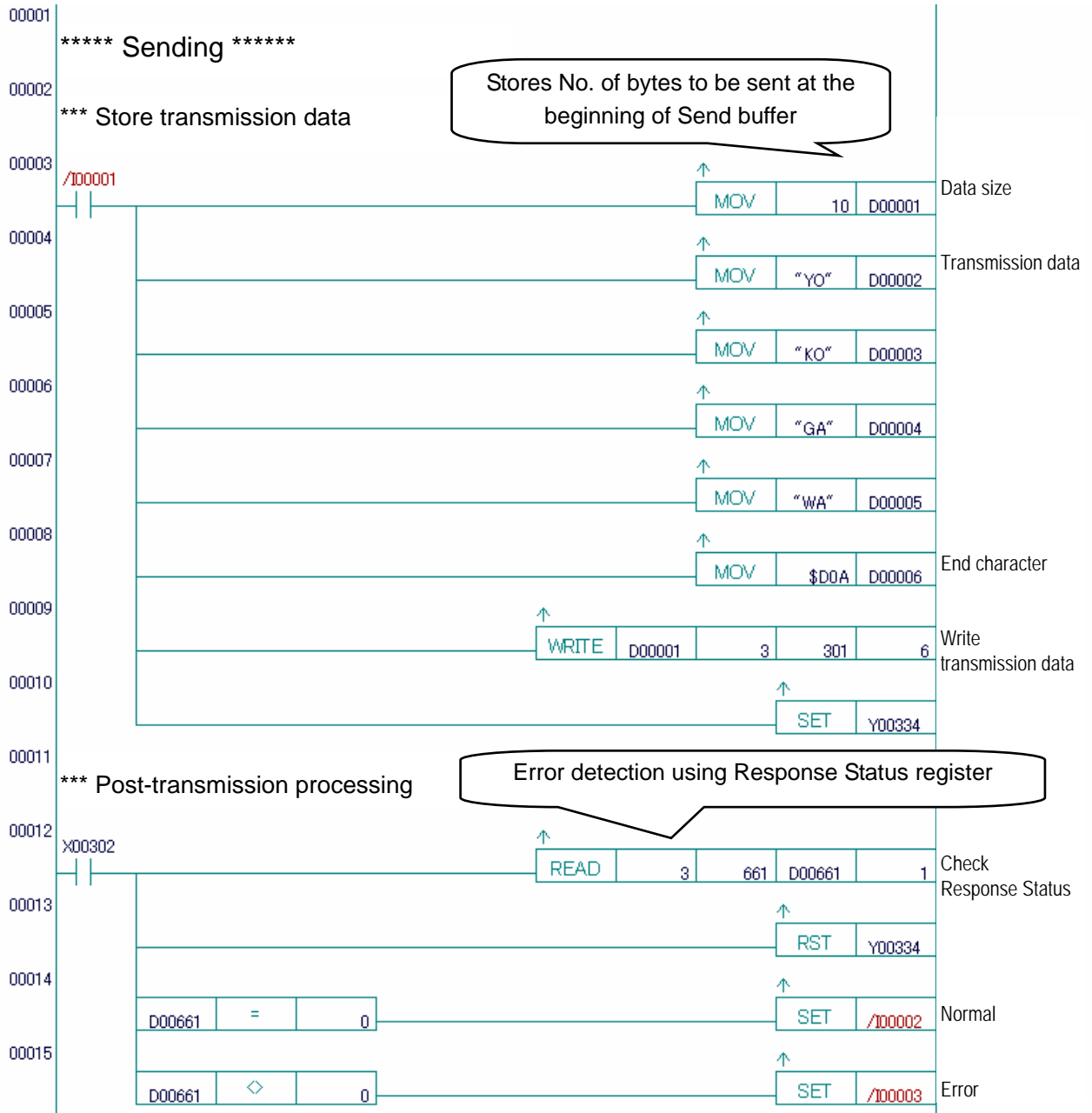

● F3RZ81-0F

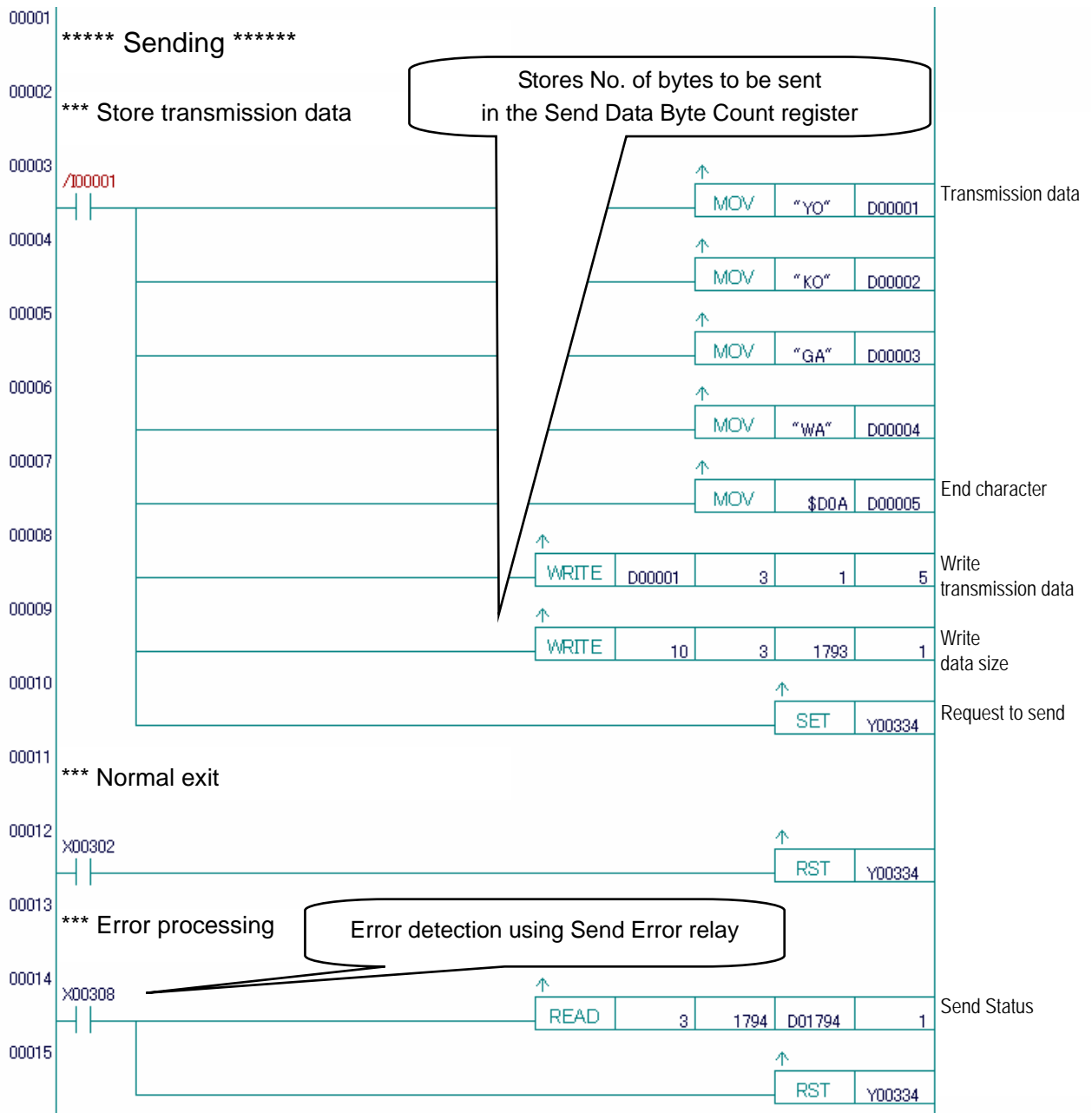

## 4. Receiving

● F3RZ81-0N

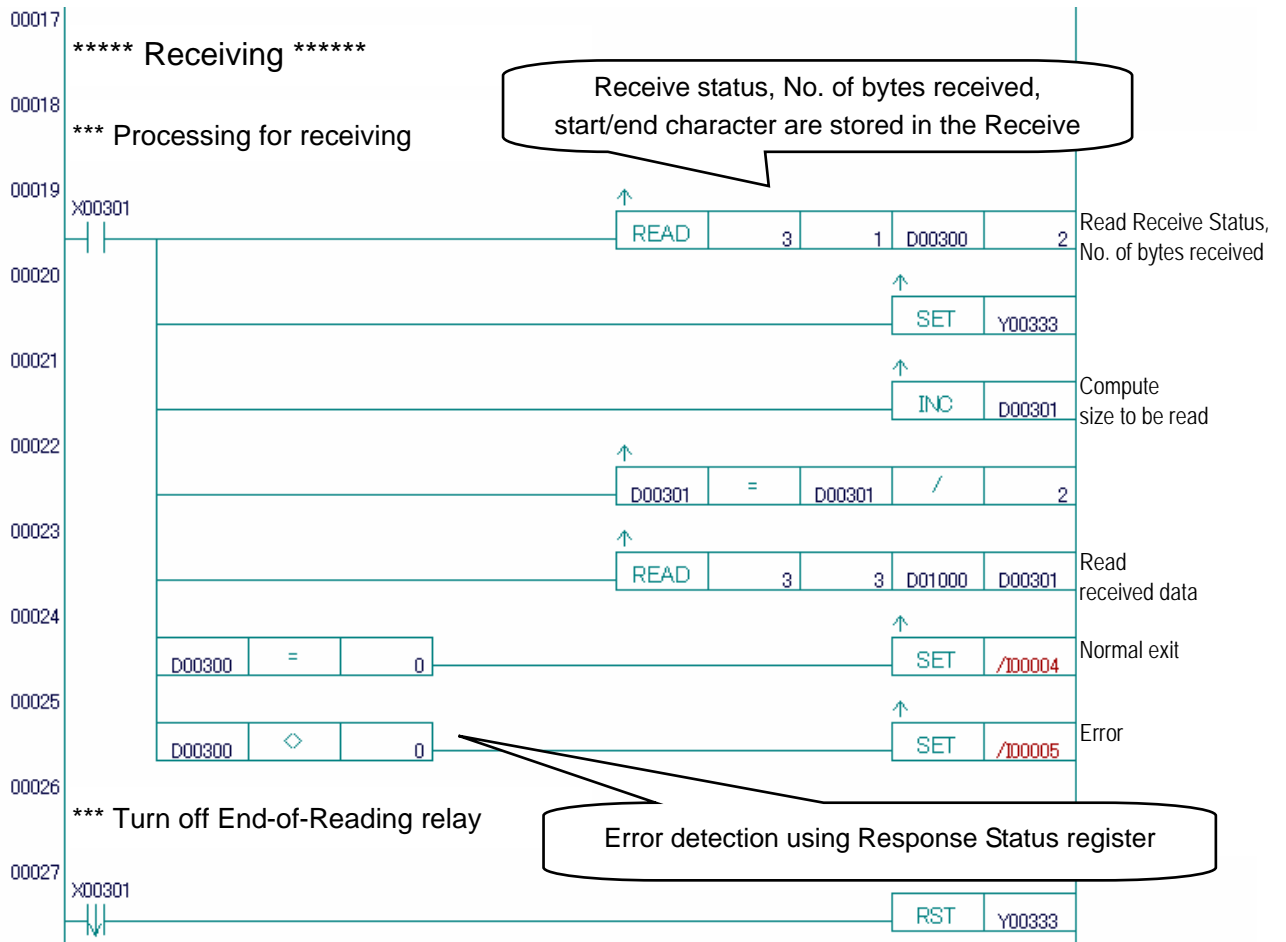

● F3RZ81-0F

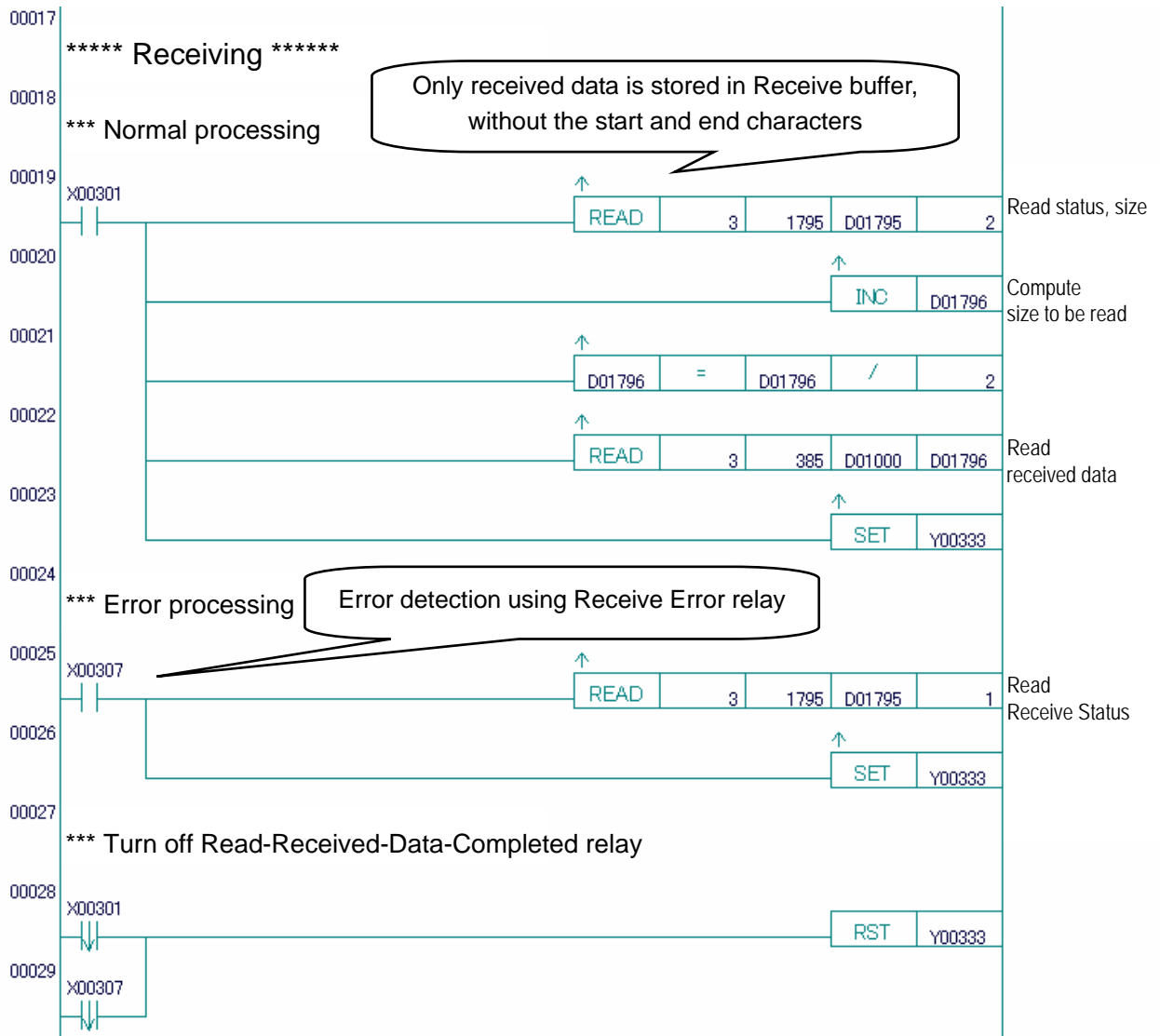

# Comparing Sample Programs for F3RZ91-0N & F3RZ91-0F

## 1. Communication setup

### ● F3RZ91-0N

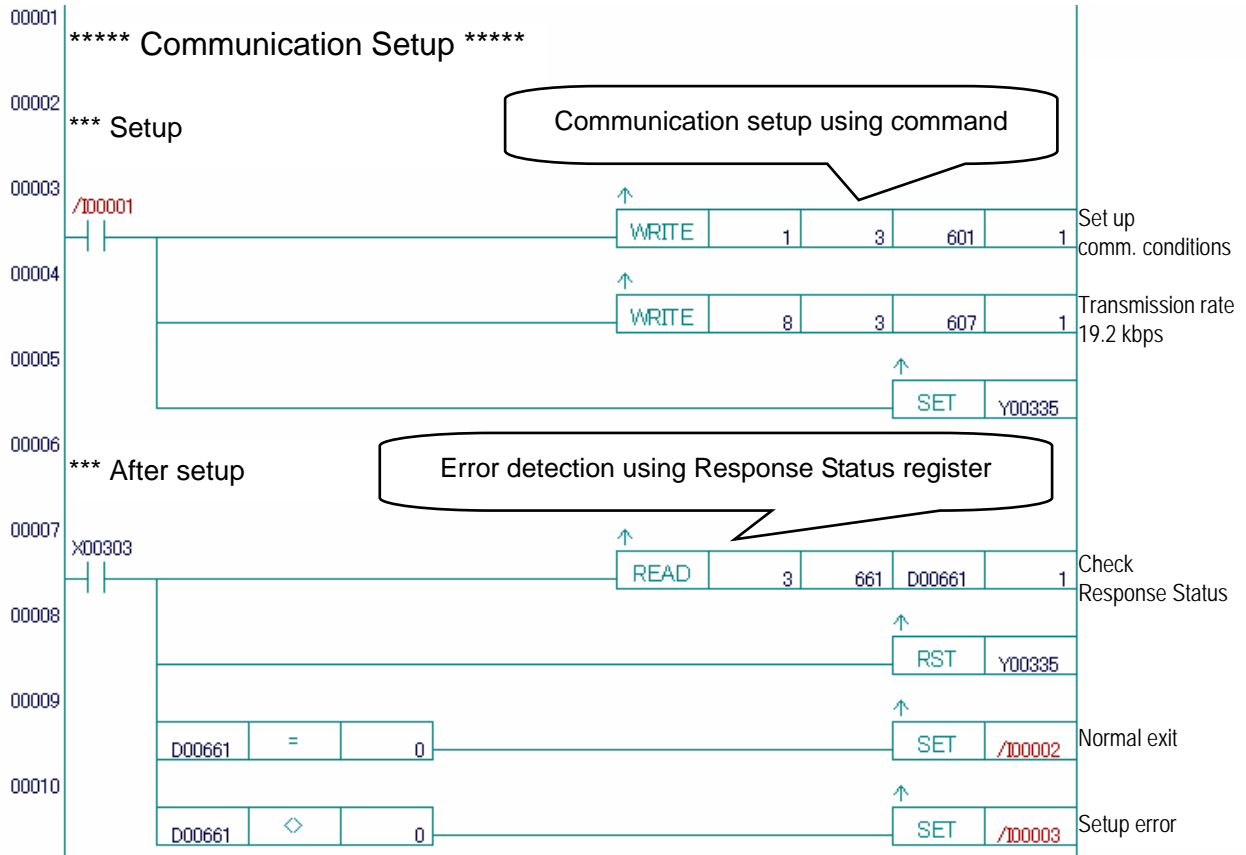

### ● F3RZ91-0F

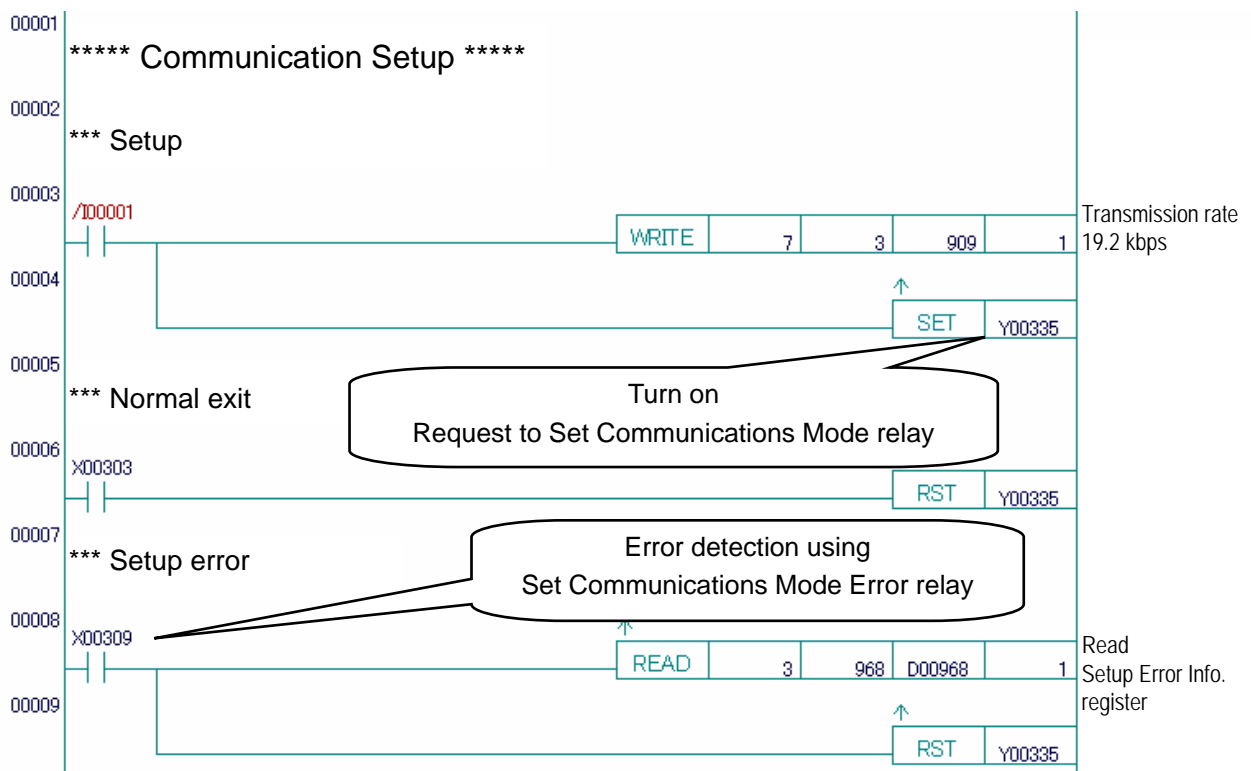

## 2. Reading Communication Settings

### ● F3RZ91-0N



### ● F3RZ91-0F

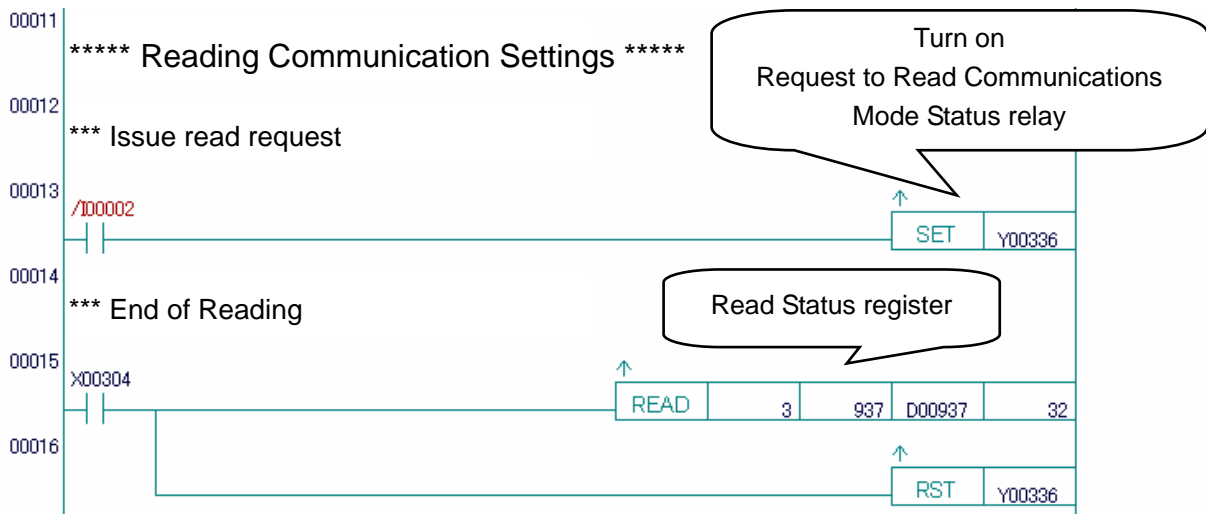

### 3. Sending

● F3RZ91-0N

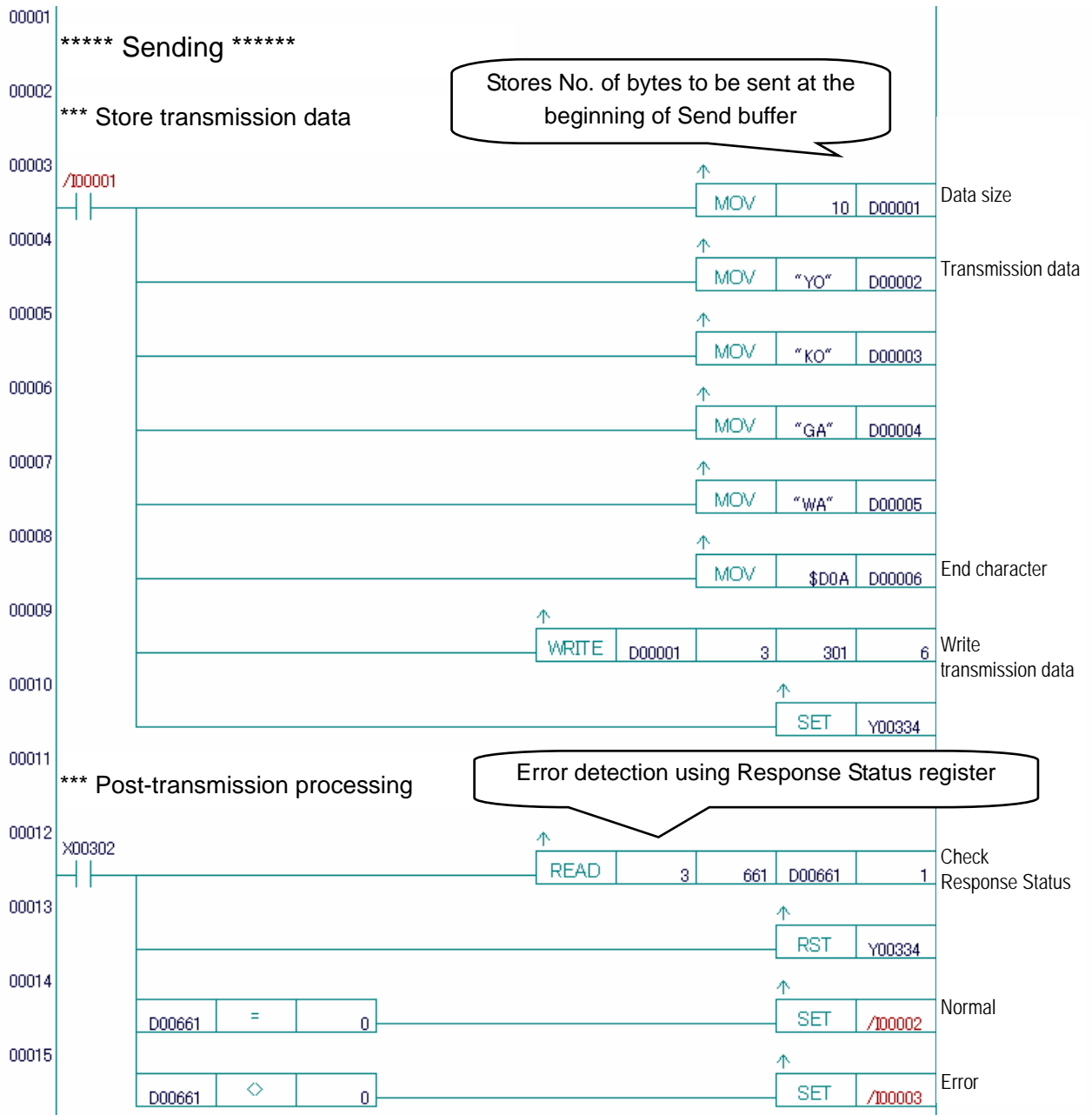

● F3RZ91-0F

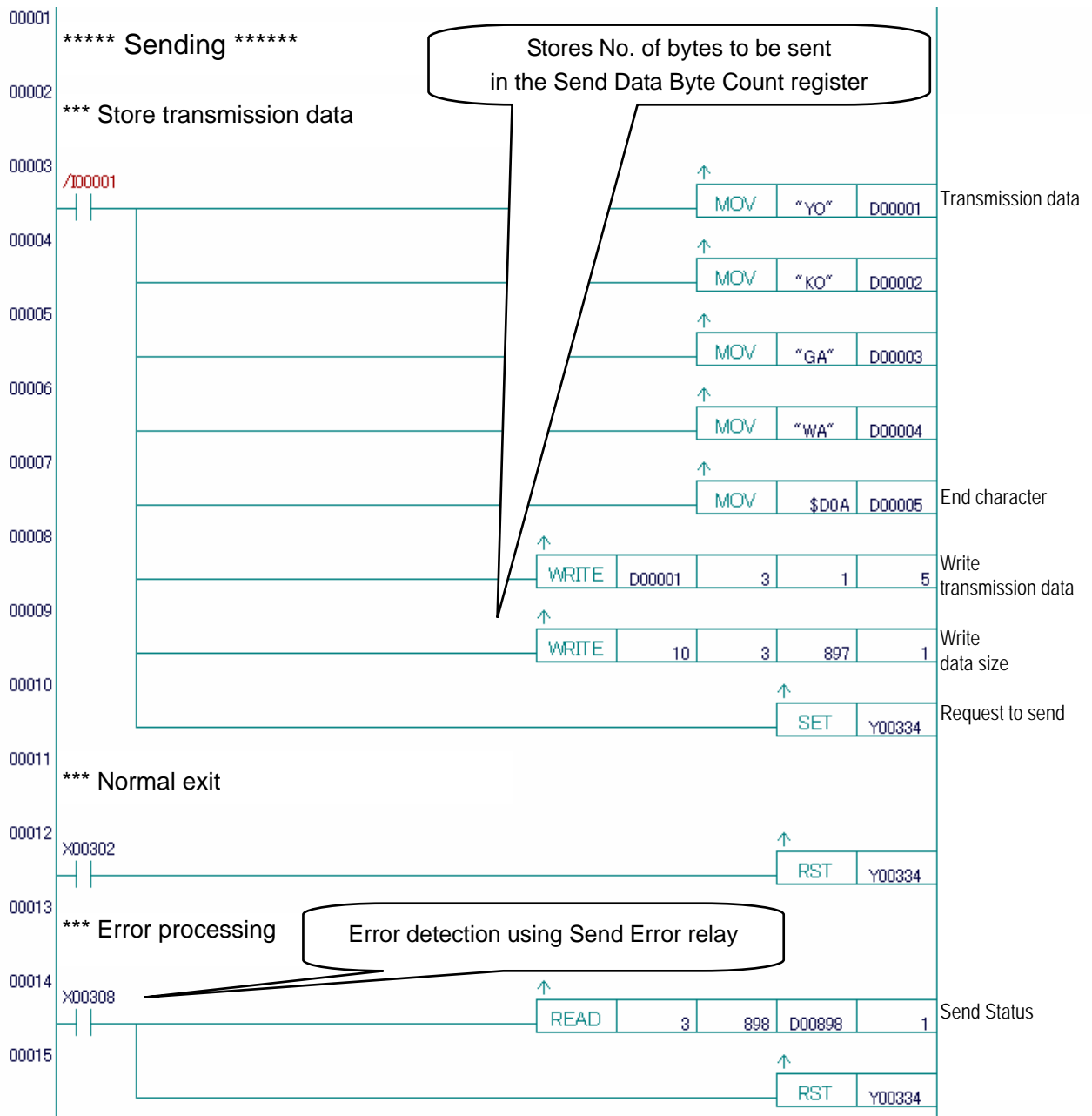

## 4. Receiving

● F3RZ91-0N

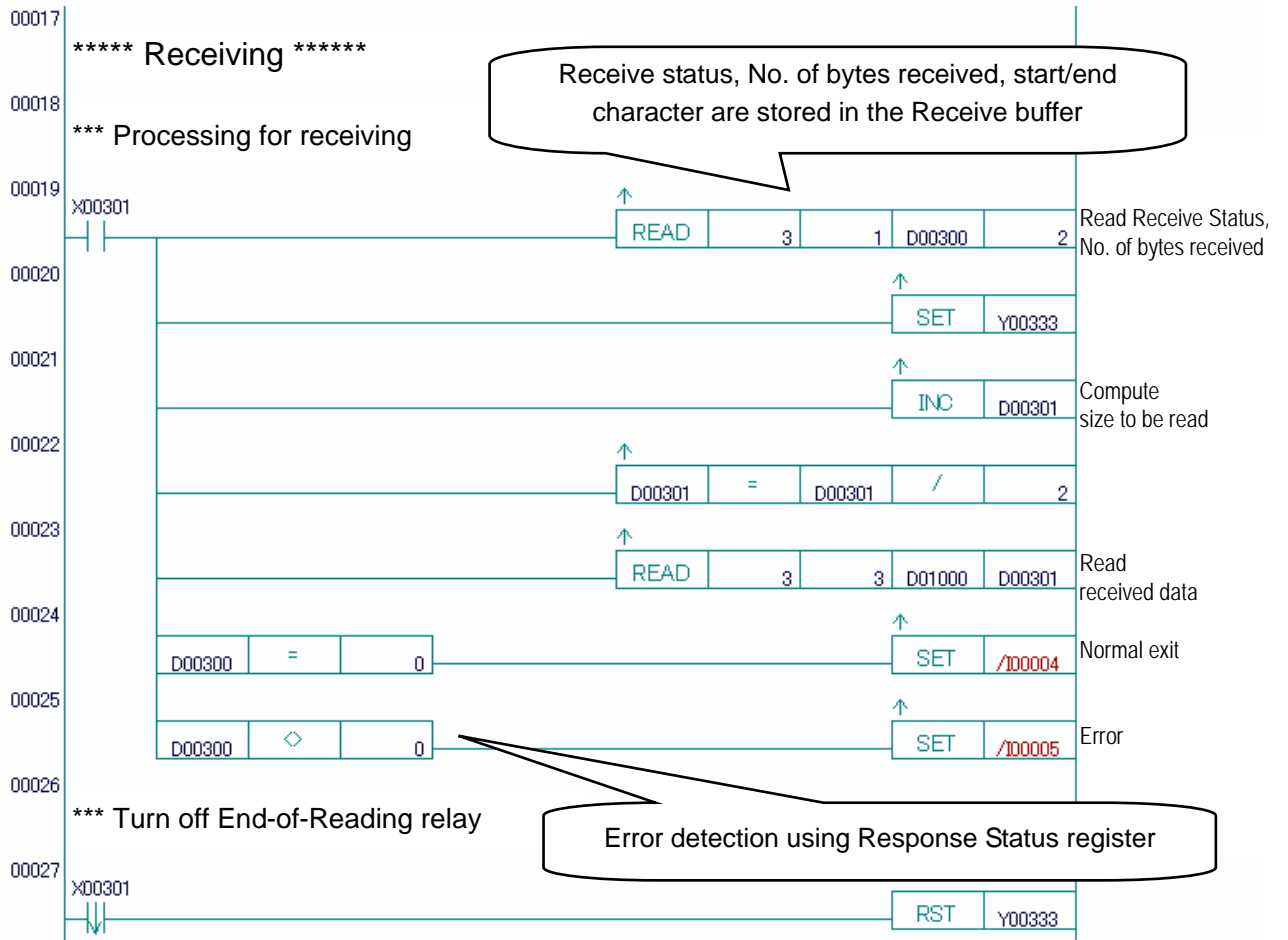

● F3RZ91-0F

