

OR100E/OR300E Recorder Specifications

Measurement input

Input type: Floating unbalanced input, I/O isolation (channel independence)
 Input mode: DC, GND, RMS (RMS is for OR300E only)
 Measurement range and accuracy: See table below.

(After zero-calibration following 30-minute warm-up at 23 ± 5°C)

Measurement range (V/div)	Measurable range	Accuracy
100mV FS(10mV/div)	± 100.0mV	± (1% of FS + 1mV)
200mV FS(20mV/div)	± 200.0mV	± (1% of FS + 1mV)
500mV FS(50mV/div)	± 500.0mV	± (1% of FS + 1mV)
1V FS(100mV/div)	± 1.000V	± (1% of FS + 1mV)
2V FS(200mV/div)	± 2.000V	± (1% of FS + 1mV)
5V FS(500mV/div)	± 5.000V	± (1% of FS + 1mV)
10V FS(1V /div)	± 10.00V	± (1% of FS + 1mV)
20V FS(2V /div)	± 20.00V	± (1% of FS + 1mV)
50V FS(5V /div)	± 50.00V	± (1% of FS + 1mV)
100V FS(10V /div)	± 100.0V	± (1% of FS + 1mV)
200V FS(20V /div)	± 200.0V	± (1% of FS + 1mV)
500V FS(50V /div)	± 500.0V	± (1% of FS + 1mV)
1000V FS(100V /div)	± 500.0V	± (1% of FS + 1mV)

Zero position: Can be moved within measurement range; null function included.
 Frequency characteristics (with filter off): DC to 40 kHz (+1/-3 dB, typical)
 Common mode rejection ratio (CMRR): 85 dB or greater (50/60 Hz; signal source resistance of 500 Ω or less)
 Low-pass filter: 5 Hz, 500 Hz, off
 Attenuation characteristic: -6 dB/octave
 Noise (with filter off, 10 mV/div range input shorted): 2.0 mVp-p (typical)
 AD resolution: 12 bits (equivalent to 11bit internal processing resolution)
 Maximum sampling speed: 400 kS/s (all channels simultaneously); 80 kS/s in wave-window
 Input impedance: 1 MΩ ± 1%, 5 pF (at 40 kHz, typical)
 Input terminal: Safety terminal (for banana plug)
 Maximum input voltage and maximum floating voltage: Between H and L input terminals, between H-L input terminal and ground

Overvoltage category	Maximum input voltage
CATII environment	500 Vrms
CATIII environment	300 Vrms

Temperature input (with temperature input adapter)

Scale: Both upper and lower limits can be set in increments of 108C.
 Position: Can be moved in increments of 108C.
 Low-pass filter: 5 Hz (fixed)
 Measurement range and accuracy: (at temperature of 23658C, following 30-minute warmup period)

Measurement range	Measurement span	Measurement accuracy
2008C range	-50 to 2008C	±28C
4008C range	-50 to 4008C	±38C
6008C range	-50 to 6008C	±58C

Memory function

Time axis: 200, 500 μs/div
 1, 2, 5, 10, 20, 50, 100, 200, 500 ms/div
 1, 2, 5, 10, 30 s/div
 1, 2 min/div
 Time axis resolution: 80 points/div (measurement period is 1/80 of time axis)
 Memory recording length: 10, 20, 50, 100, 200, 400, 800, 1600, 3200*1, 6400*2 div
 *1: Only works on odd-numbered channel when two channels are connected together.
 *2: Only works on channel 1 when four channels are connected together.
 Number of memory division blocks: 32 maximum--varies depending on installed memory length, set memory length and whether or not wave window trigger is used.
 Auto functions: Automatic printing, automatic statistical calculations, automatic saving (to external memory), automatic dialing (for faxing)
 Cursor functions: One cursor: Measurements on all channels displayed simultaneously.
 Two cursor: Time on all channels, as well as measurement differences or frequencies
 Cursor calculation function: max/min/ave/rms for cursor range, surface area of cursor range

Recording

Recording paper: Thermal paper roll (111 mm (width) X10 meters), effective recording width: 104 mm
 Paper feed accuracy: ±3%
 Chart speeds: 2, 5, 10, 30 s/div; 1, 2, 5, 10, 30 min/div; 1 hour/div

Recording formats

T-Y recording: 4 analog channels + 8 logic bits; 1, 2, and 4 division recording capability (logic recording can be turned on/off separately for each bit) measurements are recorded as digital values.
 Digital recording: X1-Y1, Y2, Y3. X axis is always 1 channel only.
 X-Y recording: Recording size: 8 div X 8 div (80 mm X 80 mm)
 Recording format options: Dots, lines
 Recording length: 20 div, 200 div, 800 div, continuous
 Recording line types: Three line thicknesses (analog waveforms)

Printing function

Printed information: List (settings), scale (units), time print marker, chart speed, chart speed modification point marker, trigger sensing position, trigger time, trigger sensing channel, grid (thin line, baseline, off), channel number, TAG, etc.
 Comments: Character string (20 characters per channel) or channel information printed in 100 mm intervals.
 Channel number: Channel number or TAG name (7 characters per channel) printed on waveform.

Real-time & memory

Description of operations: Normally memory sampling starts when trigger is detected during real-time recording.

Normal Trigger

Trigger sources: Analog channels 1-4, logic A and B, external trigger input, manual, timer
 Trigger modes: Free, Single, Repeat
 Trigger combinations (conditions): AND/OR
 Analog trigger types: Rise, fall, high, low, bi-slope, level window (in, out)
 Trigger level setting: 1% FS increments

Trigger filter: Filter or time-out (except when bi-slope is set)
 Trigger delay: -100% to 100% (in increments of 1%)

Wave-window trigger

Trigger modes: Single, repeat, free
 Frequencies: 50 Hz, 60 Hz
 Trigger combinations (conditions): OR on each analog channel
 Method for creating reference waveform: Automatically generated from current input or specified parameters
 Reference waveform parameters: Amplitude, tolerance, offset (1% increments for each), phase (in increments of 1°)
 Trigger delay: -100% to 100% (in increments of 10%)
 Sampling rates: 80 kS/s (1 ms/div), 40 kS/s (2 ms/div), 16 kS/s (5 ms/div), 8 kS/s(10 ms/div)
 Memory length: Memory cannot be linked; maximum memory length for each channel is one-half that of normal triggers.
 Maximum memory length: 800 div

Display

Screen: 5.7-inch LCD, 480X320 dots, contrast adjustable
 Backlight: Fluorescent tube, can be turned on/off manually
 Display languages: Japanese, English, Germany, French, Italy

Harmonic Analysis Mode Specifications

Fundamental wave: 50 Hz, 60 Hz or automatic (45.0 Hz to 65.0 Hz; Automatic Analysis mode only)
 Sampling rates: 25600 Hz (50 Hz), 30720 Hz (60 Hz)
 Analysis data points: 512
 Analysis orders: Fundamental wave to 40th order
 Analysis modes: Waveform Analysis, Automatic Analysis
 Sample length (in Waveform Analysis mode): 5-250 cycles, maximum 1000 cycles (4 channels linked)
 Anti-aliasing filter: Cutoff frequency: 7.5 kHz, -30 dB/oct
 Effect on analyzed range caused by aliasing: -40 dB or less
 Amplitude accuracy (voltage, current) **:
 Fundamental wave to 20th order ± (1.5% of rdg + 1.5% of FS)
 21st to 40th orders ± (1.5% of rdg + 2% of FS)
 Phase accuracy (voltage and current to fundamental wave phase tolerance) *1 *2:
 2nd order to 10th order: ±5 deg, 11th order to 40th order ±15 deg
 *1) In 50/60 Hz fixed mode (not including current clamp accuracy)
 *2) Harmonic amplitude: At FS/100 to FS
 Analyzed frequency range: 45 to 2.6 kHz (65 Hz X 40)
 Triggers: Same as OR100 trigger functions in Waveform Analysis mode (but trigger sensing rate depends on sampling rate).
 Triggers available in Automatic Analysis mode: Synchronized channel and level trigger settings, distortion factor and content of specified order.
 Analysis types: Root mean square value, content and phase angle for harmonic component of each order; and active power*, power content*, and phase angle* (overall root mean square value, overall distortion factor; active/reactive/apparent power, and power factor can be displayed)
 *: The following power measurement method is used (only works in Automatic Analysis mode; voltage output from a clamp probe is scaled to current values):
 Single-phase two-wire method (in the 4-channel model, two single-phase two-wire systems can be measured), single-phase three-wire method, three-phase three-wire method
 Saving analysis results to PC card: Analysis results can be saved to aflesh ATA memory card.
 Data format: CSV
 Saving methods: Manual and automatic (for saving continuous trends at specified intervals)
 Trend saving parameters: Root mean square value, content, phase angle, overall root mean square value, overall distortion factor, activepower, power content, phase angle, total active power, apparent power, reactive power, and power factor. Analysis trends and number of orders for saving trends to PC card can be selected separately for each channel.
 Trend saving intervals: 1 minute, 10 minutes, 30 minutes, 1 hour, 24 hours

Real-time RMS measurement

Frequency ranges: DC, 40 Hz to 1 kHz
 Measurement range: 100 mVrms to 500 Vrms
 Measurement accuracy: As shown below for 50/60 Hz, sine wave
 100 mV FS to 2 V FS: ± (2% of FS + 1 mV)
 5 V FS to 50 V FS: ± (2% of FS + 50 mV)
 100 V FS to 1000 V FS: ± (2% of FS + 0.1 V)
 Response rate: (for 0-100% of FS step input)
 Rise (0→90% of FS): 200 ms (typical)
 Fall (100→10% of FS): 310 ms (typical)
 Crest factor: 2 (measurable range for crest factor 2 is rms value of no more than 90% of f.s.)

External I/O interface

Terminal: Screwless terminal
 External trigger input: TTL level or contact (pulse width of 2 μs or greater)
 Depending on settings, can be used as input for external sampling clock (up to 100 kHz) or for starting/stopping measurement.
 External trigger output: TTL level (pulse width of 10 ms or greater; for parallel operation)

RS-232 interface

Connector: 9-pin DSUB connector (male)
 Transfer rates: 1200, 2400, 4800, 9600, 19200 bps

PC card interface

External memory:
 Supported card: Flash ATA memory card (made by SanDisk Corporation or equivalent)
 Supported card sizes: Up to 160 MB
 Function specifications: Saving settings data, measurement data, and graphical images (BMP)

Modem communications:

Supported card: Fax/modem card
 Transmission rate: 19200 bps maximum
 Fax control: EIA-592 Class 2 card must be used.
 Function specifications: ~~Sending measurement data, receiving setting commands, automatic transmission of measurement data (fax only)~~

Data recorder function

Maximum sampling rate: 1.6ks/s
 Data length for playback on recorders: 128k data/ch steps
 Note: Does not support external sampling. Only normal trigger mode is available. Trigger-ready is always 0%. Repeat trigger cannot be used.

Operation-verified PC cards

- Flash ATA memory card
 I/O DATA, Epson, Panasonic

Logic Probes (sold separately)

	788031	788035
Input type	4-channel, TTL or contact input; common input in the same probe.	4-channel, voltage input; insulation between channels.
Maximum allowable input voltage	±35 VDC	±250 Vrms
Input impedance	Approximately 10 kΩ	Approximately 100 kΩ
Threshold level	Approximately +1.4 V	Sensed: 60-250 VAC, ±30±250 VDC Not sensed: 0-10 VAC, 0-±10 VDC
Withstand voltage	500 VDC, 1 minute (between probe and case)	1.5 kVAC, 1 minute (between channels) 1.5 kVDC, 1 minute (between probe and case)

788041-1 Temperature input adapter (sold separately by Yokogawa M&C Corporation)

Attachable sensor type: Type K thermocouple
 Number of attachable sensors: One per adapter
 Terminal type: Clamp-on
 Temperature range: -50 to 600°C

Note: Thermocouples are not included and must be purchased separately by the user. Temperature input adapter model 788041 works with OR100E and OR300E only. It does not work with OR100 or OR300.

96001 Clamp probe (sold separately by Yokogawa M&C Corporation)

Measurement range: 0-400 Ams AC (600 Apk)
 Output voltage: 10m V/A (4V AC max.)

Accuracy

- Amplitude: ±1.5%rdg ±0.4 mV (20-40 Hz)
 ±1.0%rdg ±0.2 mV (40 Hz - 1 kHz)
 ±(0.8 + 0.2 X f kHz) %rdg
 ±(0.2 + 0.04 X f kHz) mV (1-20 kHz)
 Phase: ±38(40 Hz - 1 kHz)
 (Conditions: 238C ± 58C, max. 80%RH, sinewave input)

Measurable conductor diameter: 33 mm max.
 External dimensions (mm): Approximately 73 X 130 X 30 (WHD)
 Output cable length: 2.5 m

Other separately sold accessories

- Dedicated AC adapter (sold separately)
 - Rated supply voltage: 100 to 240 VAC
 - Permissible supply voltage fluctuation range: 90 to 264 VAC
 - Rated supply frequency: 50/60 Hz
 - Permissible supply frequency fluctuation range: 48 to 62 Hz
 - Maximum consumed power: 70 to 90 VA
 - Rated output voltage: 12 VDC
 - Rated maximum output current: 2.6 A
- Dedicated NiMH battery pack (sold separately)
 - Battery volume: 2100 mAh, 7.2V
 - Number of charges (cycle life):
 - Approximately 300 (varies depending on usage environment)
 - Approximately 3.5 hours (on trigger standby without options)
 - Approximately 3 hours (when recording 1 Hz cycle waveform in 2 S/div)
 - Charging function: Charged in the recorder, connect the dedicated AC adapter and turn off the power switch to enter charge mode. Charging time is approximately 1.5 hours.
- DC converter (sold separately)
 - Allowed input voltages: 788025-1: 9-18 VDC
 788025-2: 18-36 VDC
 788025-3: 36-60 VDC
 - Output voltage: 12V ± 5%
 - Power consumption: Approximately 25VA maximum
 - Terminal type: Screw terminal (lead wire approximately 5 meters long included)

General specifications

Measurement modes: Memory, Real-Time Recorder, Real-time Recording & Memory, Harmonic Analysis (OR300E only)
 Channels: Analog: 2 channels or 4 channels
 Logic: 8 bits (maximum of 2 four-bit probes can be connected)
 Internal memory capacity: 128K per channel (or 256K data per two linked channels, 512K data per four linked channels)
 Internal memory type: SRAM (battery backup)
 Power supply: Commercially available AA alkaline dry cells or special AC adapter, special NiMH battery pack, special DC converter for external DC power source.
 When both the AC adapter and batteries are connected, the AC adapter is used first.
 Power consumption: Using AC adapter: 25 VA maximum
 Using batteries: 20 VA maximum
 AA/R6 dry cells: Six AA/R6 alkaline dry cells (JIS, IEC model name: LR6)
 Alkaline dry cell running time: Approximately 2 hours (on trigger standby without options)
 Approximately 1/2 hour (when recording 1 Hz cycle waveform in 2 S/div) (about 10 minutes shorter with OR300E)
 Warm-up time: 30 minutes
 Withstand voltages: Between recorder and special AC adapter power line: 2 kVAC for 1 minute
 Between recorder and analog input terminal: 2 kVAC for 1 minute
 Between input terminals: 2 kVAC for 1 minute

Insulation resistance: Between recorder and special AC adapter power line: Minimum 10 MΩ at 500 VDC
 Between recorder and analog input terminal: Minimum 100 MΩ at 500 VDC
 Between input terminals: Minimum 100 MΩ at 500 VDC

Allowed signal source resistance: Maximum 500Ω

Environment: Usage temperature and humidity: 5 to 40°C, 35 to 80% RH (Note: Wet-bulb temperature of 29°C or less, no condensation.)

Storage temperature and humidity: -20 to 60°C, 90% RH (Note: Wet-bulb temperature of 29°C or less, no condensation; NiMH battery and alkaline dry cells not included.)

Clock accuracy: ±100 ppm (typical)

Battery backup: Lithium battery for backing up settings, waveform data and clock
 Life of lithium battery for backup: Approximately 5 years (at room temperature)

External dimensions: Approximately 256 (H) X 190 (W) X 46 (D) mm
 Weight: OR122 (2-channel model): Approximately 1.3 kg (not including batteries or chart)
 OR142 (4-channel model): Approximately 1.4 kg (not including batteries or chart)
 OR322 (2-channel model): Approximately 1.4 kg (not including batteries or chart)
 OR342 (4-channel model): Approximately 1.5 kg (not including batteries or chart)

Accessories: Printer paper (111 mm X 10 meter roll; part number: B9988AE); 1 roll
 Measurement input leads for voltage input (model 366963); Leads for each channel
 AA/R6 alkaline dry cells (part number: A1070EB): 6
 Belt (part number: B9988CK): 1 set
 Instruction Manual: 1

ACRAWin32 PC software

Data display: Displays waveform data measured and saved using OR100E, OR300E, OR1400. (supported recorders differ depending on software model)
 OR300E harmonic analysis results cannot be redrawn.

Data conversion: Conversion to ASCII, Lotus 1-2-3 and Excel formats.

Number of displayed waveforms: Maximum simultaneous display of 16 analog waveforms and 16 logic waveforms (displayed separately for each file; maximum number of simultaneous waveforms varies depending on model)

Calculation function: Use cursor to select range on waveform display screen or digital value display screen. Minimum, maximum, P-P, average and root mean square values are calculated.

Communication with recorders (destinations): Enter the desired recorder name, and set details such as the access method, communicated information schedule, data type selection, and password during communication. Next start or stop communication (OR100E/OR300E only).

PC: The PC must be running Windows 95, 98 or Windows NT 4.0 or higher, have a Pentium 90 MHz CPU or higher, have at least 16 MB of RAM and at least 5 MB free hard drive space.

Serial port and modem: For communication between a PC and the OR100E/OR300E using the OR100E/OR300E Connector communication software, the PC must be connected through a serial port (RS-232) or modem. In addition, the operating system must recognize the communication devices.

RS-232 cable and adapter: For serial communication, an RS-232 cable with reverse-connected

System Components

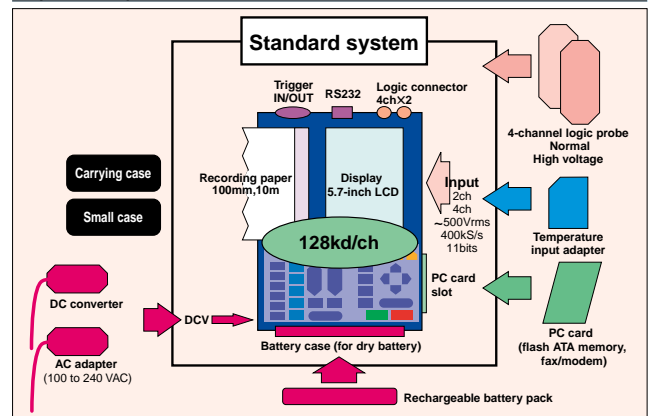

Supported standards

CSA	Obtained CSA22.2 No.1010.1 Installation category (Overvoltage category) : II, III Degree of pollution : 2	
CE	EMC directive	EN61326
		EN61000-3-2
		EN61000-3-3
	EN55011 Class A Group 1	
Low voltage directive	EN61010-1	
	Measurement category : II, III Degree of pollution : 2	
C-Tick	AS/NZS 2064 Class A Group 1	

Peripheral Equipment



788011
AC adapter



788021
Rechargeable battery pack



788025
DC-DC converter



788031
Logic probe (±35VDC)



788035
Logic probe (±250Vrms)



788081
Carrying case



788082
Small case

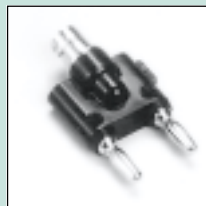

366922
Conversion adapter



366963
Measurement lead



96001
Clamp probe*



788041
Temperature input adapter

*:Product of YOKOGAWA M&C Corporation

Model and suffix codes

OR100E (standard model)

Model	Suffix code	Description
OR122		2-channel isolated input model*
OR142		4-channel isolated input model*
Display language	-2	English (including key panel)
Options	/P □***	Accessory pack**

OR300E (harmonic analysis model)

Model	Suffix code	Description
OR322		2-channel isolated input model*
OR342		4-channel isolated input model*
Display language	-2	English (including key panel)
Options	/P □***	Accessory pack**

* : Standard-equipped with measurement cables for each analog input channel.

** : Includes AC adapter, rechargeable battery pack and carrying case (788081).

*** : D (for UL/CSA), F (for VDE), R (for SAA), S (for BS), H (for CCC)

Separately sold accessories

788011		AC adapter
	□*1	Power code
788021		Rechargeable battery pack *2
788025		DC converter
	-1	For connecting external 12 VDC power supply
	-2	For connecting external 24 VDC power supply
	-3	For connecting external 48 VDC power supply
788031		4-channel logic probe *3
788035		4-channel high voltage logic probe (each channel isolated) *4
788041		Temperature input adapter
	-1	For type K thermocouple
788081		Carrying case
788082		Small carrying case

*1: D (for UL/CSA), F (for VDE), R (for SAA), S (for BS), H (for CCC)

*2: Be sure to get an AC adapter (788011) if you are getting a rechargeable battery pack.

*3: Includes IC clip and crocodile leads.

*4: Includes crocodile leads.

PC Software

789501		Viewer for OR100E/OR300E only and OR100E/OR300E connector software
789502		Viewer software for OR100E/OR300E, OR1400 and ORM
789503		Viewer software for OR100E/OR300E, OR1400 and ORM, and OR100E/OR300E connector software
	-02	English

Accessories

B9988AE		111 mm × 10 meter roll paper
---------	--	------------------------------

NOTICE

- Before operating the product, read the instruction manual thoroughly for proper and safe operation.
- If this product is for use with a system requiring safeguards that directly involve personnel safety, please contact the Yokogawa sales offices.