

GS AR03-01E

General

This high quality arrester protects electronic instruments by absorbing induced lightning surge voltage. Arrester should be set between lines through which surges are entered and serves to protect instruments such as transmitters or receivers safely from thunder inducement.

Cautionary Notes for Safe Use of the Product

The arrester may deteriorate or break if it receives surges. Arresters that have deteriorated below a specific level or are broken, may fail to meet their protection performance level and must therefore be replaced. When replacing such arresters, replace both the main unit and the terminal block. It should be noted that the arrester may fail to safeguard the equipment under protection if it receives any surges exceeding its tolerance limit, such as direct lightning strokes.

Model and Suffix Codes

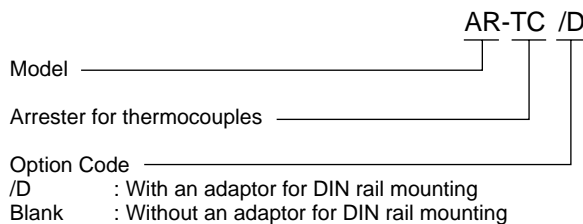

Input and Output

Input Signal: Thermocouples (mV signal line)
Output Signal: Thermocouples

Standard Performance

Permissible current leakage:
Between lines: 2 μ A or less (at 8 V DC)
Between ground : 10 μ A or less (at 50 V DC)
Instrument side voltage limit:
Between lines: 30 V or less (at 10 kV, 1.2/50 μ s)
Between ground: 250 V or less (at 10 kV, 1.2/50 μ s)
Surge discharge withstand capacity:
5000 A (at 8/20 μ s)
Discharge starting voltage:
Between lines: 20 V DC or more
Between ground: 74 V DC or more
Temperature: -10 to +60°C
Humidity: 5 to 90% RH (no condensation)

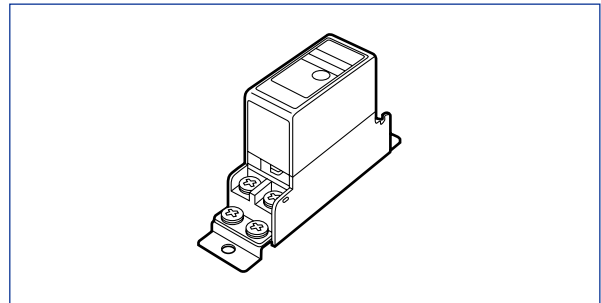

Safety Standards

Conforms to EN61010-1 Installation Category II

Mounting and Appearance

Construction: 2 sections construction of main body and terminal base: plug-in +screw fastening

Material: Black, flame deterrent ABS resin (Case body)
Black, flame deterrent ABS resin (Terminal base)

Grounding: JIS Class D grounding [100 Ω or less] (with grounding bar)

Mounting Method: Wall mounting with M4 screw
Connection Method: M4 screw terminal connection (fastening torque 1.2 N-m or less)

External Dimension: 100×23.5×55 mm (H×W×D)
Mounting Dimension: 90 mm

Multi-mounting pitch: 24 mm

Weight: Approx. 110 g

Additional Specs.

/D	Adaptor for DIN rail mounting AR8-01: 1	Specs. of AR8-01 External dimensions: 104×23×8.5 mm For DIN rail 35 mm mounting Material: ABS resin 2 screws for connecting Main body and Adaptor
----	--	---

Terminal Arrangement & Terminal Connection

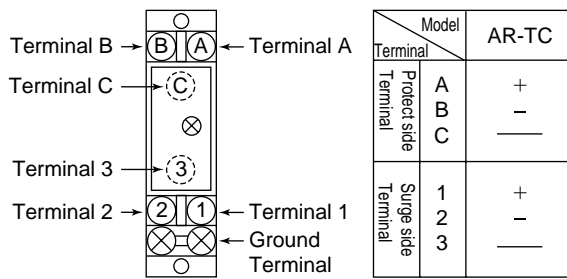

WIRING

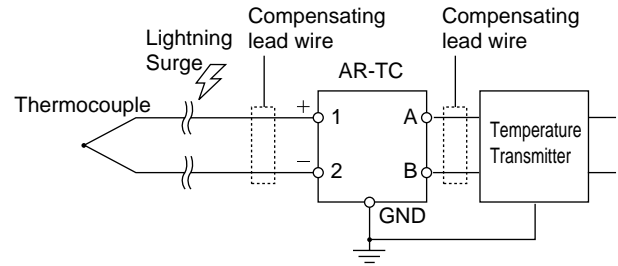

Block Diagram

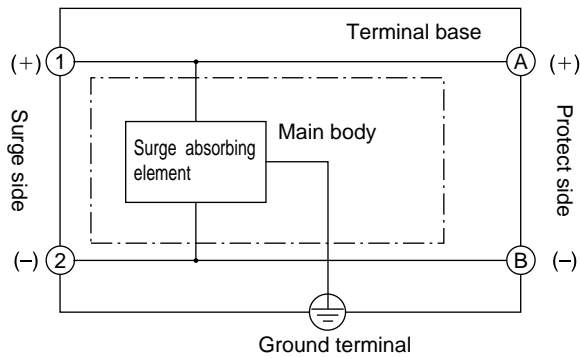

External Dimension

