

This high quality arrester protects communication equipment from lightning surges induced in communication line.

- Applicable to communication lines having frequency range of DC~20kHz and voltage range of 0~24V DC.
- Screw terminal connection makes easy relay to communication lines.
- No affect for communication lines even if main body is removed.
- Minimum mounting space would be enough because of its compact shape same as arresters for signal use.

Cautionary Notes for Safe Use of the Product

The arrester may deteriorate or break if it receives surges. Arresters that have deteriorated below a specific level or are broken, may fail to meet their protection performance level and must therefore be replaced. When replacing such arresters, replace both the main unit and the terminal block. It should be noted that the arrester may fail to safeguard the equipment under protection if it receives any surges exceeding its tolerance limit, such as direct lightning strokes.

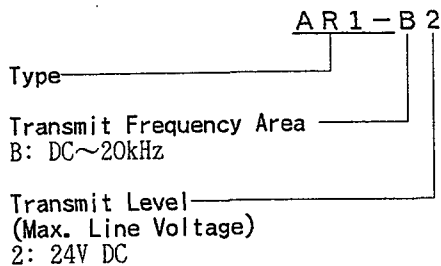

Principal Usage ...for use between line and installation intervals for low withsatnd voltage equipment

- AC, DC communication
- Signal, data transmission
- Telemeter

Standard Performance	
Transmit Frequency Area	DC~20kHz
Operational attenuation	less than 0.5 dB
Transmit level	24V DC
Permissible current leakage :	
Between lines	: Less than 5 μ A (at 25V DC)
Between ground	: Less than 5 μ A (at 25V DC)
Instrument side voltage limit :	
Between lines :	
Less than 50V	(initial maximum value)
Less than 10V	(maximum value during operation)
Between ground :	
Less than 100V	(initial maximum value)
Less than 20V	(maximum value during operation)
Surge discharge withstand capacity :	
4kA (at 8/20 μ s)	
Discharge starting voltage :	
Between ground : 30V DC or more	
Series resistance	5 Ω ±10% (one line)
Temperature range	-10~+60C
Humidity range	5~90% RH (no condensation)
Mounting & Shape	
Construction : 2 sections construction of main body and terminal base; plug-in+screw fastening	
Material	Case body : Black, unflammmable ABS plastic Terminal base : Black, unflammmable ABS plastic
Grounding	JIS Class D grounding [less than 100 Ω] (with grounding bar)
Mounting method	Wall mounting with M4 screw
Connecting method	M4 screw terminal connection (fastening torque less than 1.2N·m)
External dimension	100×23.5×55 mm (H×W×D)
Mounting dimension	90mm
Multi-mounting pitch	24mm
Weight	Abt. 110g

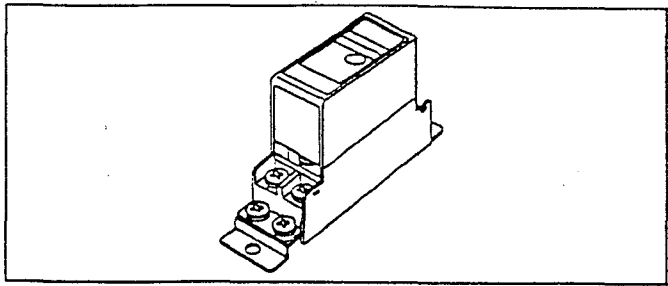

WIRING

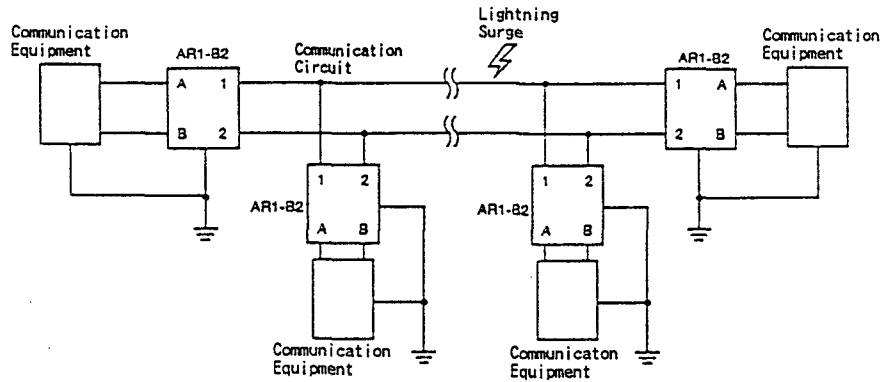

TERMINAL ARRANGEMENT

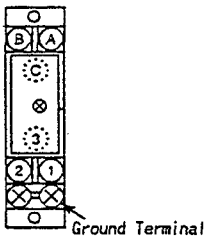

	Usage	Communication Line
Protect side Terminal	A	L1
	B	L2
	C	—
Surge side Terminal	1	L1
	2	L2
	3	—

BLOCK DIAGRAM

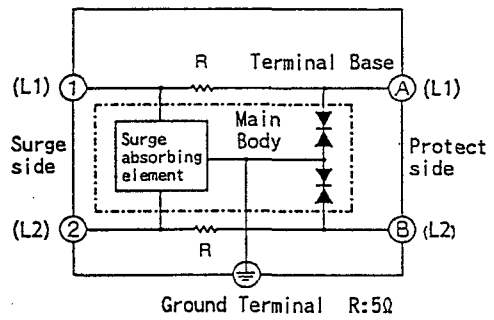

EXTERNAL DIMENSION

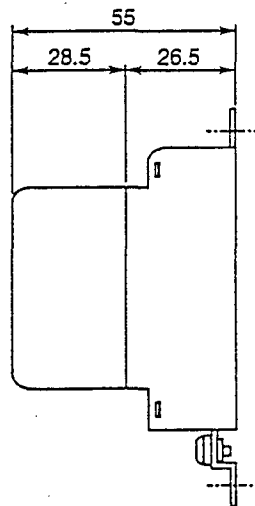
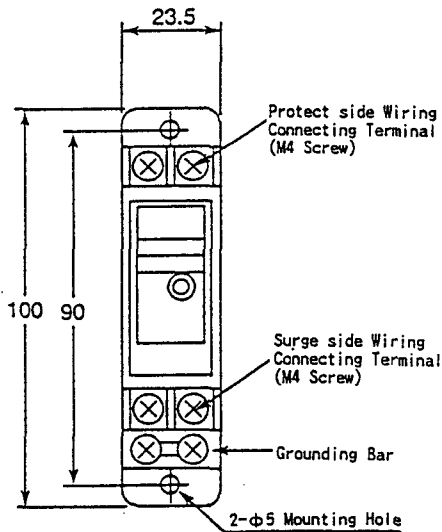

Unit : mm

Subject to change without notice for grade up quality and performance