

General Specifications

Model CFS1100 Safety Control Functions Package



GS 32S03B10-21E

■ GENERAL

Safety Control Functions Package is a software package that monitors a plant to ensure it is operating safely. The package also performs preset safety operations in response to requests for safety control.

■ FUNCTIONAL SPECIFICATIONS

The following describes the configuration and functions of the package:

● Configuration of CFS1100 Safety Control Functions Package

The CFS1100 Safety Control Functions Package operates on Safety Control Stations (SCSs). The functions of the package can be divided into two groups: the application logic execution function group and the external connection function group. The application logic execution function group executes safety applications. The external connection function group performs communications with non-SCS equipment. For example, this function group integrates the CENTUM VP/CS 3000 (hereinafter, "VP/CS 3000") with the package.

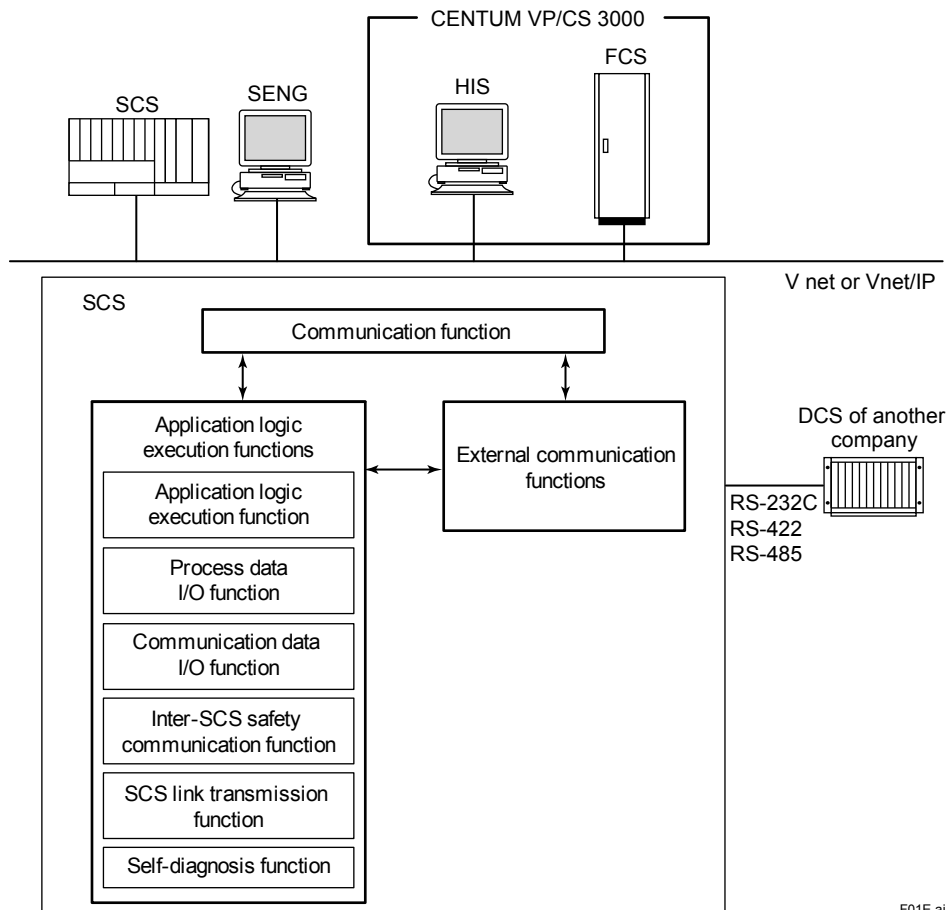

F01E.ai

Application Logic Execution Functions

This function group is the main part of the package that monitors the plant to ensure it is operating safely, and performs preset safety operations if any abnormalities occur. This group is composed of the following functions:

- Application logic execution function
- Process data I/O function
- Communication data I/O function (Subsystem communication function)
- Inter-SCS safety communications function
- SCS link transmission function
- Self-diagnosis function

External Communication Functions

This function group, which performs communications between the application logic execution functions and non-SCS equipment, is composed of the following functions:

- VP/CS 3000 integration function
- Modbus connection function
- Sequence-of-events recorder (SOER) function
- Diagnosis information collection function

● **Application Logic Execution Functions**

The application logic execution function, process data I/O function, inter-SCS safety communication functions and SCS link transmission function are given below.

Application Logic Execution Function

This function can be created by using the Function Block Diagram (FBD), the Ladder Diagram (LD) or Structured Text (ST), all of which are compliant with the IEC 61131-3.

The tables below list the functions and function blocks used in the FBD. Some elements from LD can also be used.

Table Functions (FU) (1/2)

Function	Details
ABS	Gives the absolute (positive) value of a real value
SQRT	Calculates the square root of a real value
+ADD	+, meaning "addition"
× MUL	×, meaning "multiplication"
– SUB	–, meaning "subtraction"
/ DIV	/, meaning "division"
SHL	Make the bits of an integer shift to the left. Shift is made on 32 bits. Zero is used to replace lowest bit.
SHR	Make the bits of an integer shift to the right. Shift is made on 32 bits. Highest bit is copied at each shift.
ROL	Make the bits of an integer rotate to the left. Rotation is made on 32 bits.
ROR	Make the bits of an integer rotate to the right. Rotation is made on 32 bits.
AND	AND
OR	OR
XOR	Exclusive disjunction (exclusive OR)
NOT	Negation
SEL	Selects one of two input values (INTEGER)
SEL_R	Selects one of two input values (REAL)
SEL_T	Selects one of two input values (TIME)
MAX	Selects the larger of two input values (INTEGER)
MIN	Selects the smaller of two input values (INTEGER)
LIMIT	Limits the range of the input values to output (INTEGER)
MUX4	Selects one of four input values (INTEGER)
MUX8	Selects one of eight input values (INTEGER)
MUXBOOL4	Selects one of four input values (BOOL)
MUXBOOL8	Selects one of eight input values (BOOL)
MUXREAL4	Selects one of four input values (REAL)
MUXREAL8	Selects one of eight input values (REAL)
GT	>, meaning "greater than"
GE	>=, meaning "greater than or equal to"
EQ	=, meaning "equal"
LE	<=, meaning "less than or equal to"
LT	<, meaning "less than"
NE	≠, meaning "unequal"
SCALER	Converts a 0-100 % range of input values into a normalized range for outputting
1GAIN	Assignment

Table Functions (FU) (2/2)

Function	Details
IB_TO_V	Converts IO_BOOL-type input to data value
IB_TO_S	Converts IO_BOOL-type input to data status
IR_TO_V	Converts IO_REAL-type input to data value
IR_TO_S	Converts IO_REAL-type input to data status

Table Interference-free (*1) Functions (FU)

Function	Details
ANY_TO_BOOL	Converts to BOOL-type
ANY_TO_DINT	Converts to INTEGER-type
ANY_TO_REAL	Converts to REAL-type
ANY_TO_TIME	Converts to TIME-type
POW	Performs power calculation
ACOS	Calculates the Arc cosine of a real value
ASIN	Calculates the Arc sine of a real value
ATAN	Calculates the Arc tangent of a real value
COS	Calculates the Cosine of a real value
SIN	Calculates the Sine of a real value
TAN	Calculates the Tangent of a real value
LOG	Calculates the Common logarithm of a real value
MOD	Calculates the Modulo of an integer value

*1: Functions not affecting the safety loop

Table Function Blocks (FB) (1/2)

Function block	Details
SR	Set dominant bistable
RS	Reset dominant bistable
R_TRIG	Detects a rising edge
F_TRIG	Detects a falling edge
CTU	Count up counter
CTD	Count down counter
CTUD	Count up/down counter
TP	Pulse timer which outputs pulses for a specified duration after rising edge detection
TON	On-delay timer
TOF	Off-delay timer
REPEATTIMER	Alternates TRUE and FALSE outputs at specified intervals
FILTER	First-order lag filter
FILTER_S	First-order lag filter with data status analysis capability
ANLG1002D	1oo2D analog voter
ANLGVOTER	3-input analog voter (IO_REAL)
BOOLVOTER	3-input BOOL voter (IO_BOOL)
ANLG_S(*1)	Outputs high/low alarm with scale conversion (with data status input)
ANLGI(*1)	Outputs high/low alarm with scale conversion
VEL(*1)	Detects the velocity limit exceeded

*1: When the VP/CS 3000 Integrated Engineering Package is used in conjunction with this package, the HIS of the VP/CS 3000 can perform operations and monitoring.

Table Function Blocks (FB) (2/2)

Function block	Details
SYS_STAT	Manages the SCS status
SYS_FORCE	Manages forcing
SYS_DIAG	Outputs diagnosis information
SYS_SECURE	Manages Security level
SYS_SEC_CTL	Protects Security level
SYS_IOALLST	Detects fault in all I/O channels
SYS_NODEST	Detects fault in all I/O channels in node
SYS_OUTST	Detects fault in output module channels (for 8 channels)
SYS_OUTST16	Detects fault in output module channels (for 16 channels)
SYS_INST	Detects fault in input module channels
SYS_CHST	Detects fault in channels
SYS_CERR	Indicates computation errors
SYS_SCANEXT	Indicates the extension of scan period
SYS_OVR	Manages override function blocks
SYS_PSWD	Manages password function blocks
SYS_OUTEN	Indicates Output module output status
SYS_ALLSD	Shuts down Station output
SYS_IOSD	Shuts down Module output
SYS_FORCE_BD	Manages forcing of inter-SCS safety communication data
SYS_FORCE_LT	Manages forcing of SCS Link Transmission
SYS_LTSTS	Indicates SCS Link Transmission reception status
GOV_B	Grouping overrides from HIS (BOOL)
GOV_IB	Grouping overrides from HIS (IO_BOOL)
OVR_B(*1)	Overrides from HIS (BOOL)
OVR_I(*1)	Overrides from HIS (INTEGER)
OVR_R(*1)	Overrides from HIS (REAL)
OVR_IB(*1)	Overrides from HIS (IO_BOOL)
OVR_IR(*1)	Overrides from HIS (IO_REAL)
PASSWD(*1)	Manipulates BOOL-type data using password from HIS
MOB_11(*1)	Data manual operation with two-position answerback (BOOL)
MOB_21(*1)	Data manual operation with three-position answerback (BOOL)
MOB_RS(*1)	Auto-reset data manual operation (BOOL)
MOA(*1)	Analog-type data manual operation
CONS_B	Receives data on consumer side for inter-SCS safety communication (BOOL)
CONS_I	Receives data on consumer side for inter-SCS safety communication (INTEGER)
CONS_R	Receives data on consumer side for inter-SCS safety communication (REAL)
PROD_B	Transmits data on producer side for inter-SCS safety communication (BOOL)
PROD_I	Transmits data on producer side for inter-SCS safety communication (INTEGER)
PROD_R	Transmits data on producer side for inter-SCS safety communication (REAL)
B_TO_IB	Converts data values and status to IO_BOOL-type outputs
R_TO_IR	Converts data values and status to IO_REAL-type outputs
LTRCV	Receives Safety Link Transmission data
LTSND	Sends Link Transmission data
ANN_FUP (*1)	Detects the first-up alarm and transmits the annunciator message
FUP_RST	Resets the first-up alarm annunciator

*1: When the CENTUM VP/CS 3000 Integration Engineering Package is used in conjunction with this package, the HIS of the VP/CS 3000 can perform operations and monitoring.

Table Interference-free (*1) Function Blocks (FB)

Function block	Details
ANN(*2)	Transmits annunciator message
SYS_SCAN	Outputs application logic execution time and percentage of CPU idle time
SYS_IOMDSP	Outputs the IOM status
SYS_NODEINF	Outputs node status
SYS_ESBINF	Outputs ESB bus status
SYS_NETST	Outputs Control bus status
SYS_ALRDSP	Outputs status of subsystem communication modules
SYS_ALARM	Outputs alarm transmission status
SYS_TIME	Outputs SCS clock information
SYS_FORCE_SC	Manages forcing of subsystem communication data
SYS_STAT_SC	Indicates output enable operation in subsystem communication
SOE_B	BOOL-type data SOER
SOE_I	INTEGER-type data SOER
SOE_R	REAL-type data SOER
ECW_B(*2)	Sets data of a BOOL-type variable from an external device
ECW_I(*2)	Sets data of a INTEGER-type variable from an external device
ECW_R(*2)	Sets data of a REAL-type variable from an external device
AVERAGE	Calculates the average of a specified duration
LIM_ALARM	Hysteresis on a real value for high and low limits
SCI_B(*2)	Input from subsystem (BOOL)
SCI_I(*2)	Input from subsystem (INTEGER)
SCI_R(*2)	Input from subsystem (REAL)
SCO_B(*2)	Output to subsystem (BOOL)
SCO_I(*2)	Output to subsystem (INTEGER)
SCO_R(*2)	Output to subsystem (REAL)
LTFCS	Receives Interference-free Link Transmission data

*1: Functions not affecting the safety loop

*2: When the CENTUM VP/CS 3000 Integration Engineering Package is used in conjunction with this package, the HIS of the VP/CS 3000 can perform operations and monitoring.

Table Ladder Elements

Ladder	Details
Direct Contact	Direct contact
Inverted Contact	Inverted contact
Contact with Rising Edge Detection	Contact with rising edge detection
Contact with Falling Edge Detection	Contact with falling edge detection
Direct Coil	Direct coil
Inverted Coil	Inverted coil
SET Coil	SET coil
RESET Coil	RESET coil
Coil with Rising Edge Detection	Coil with rising edge detection
Coil with Falling Edge Detection	Coil with falling edge detection

Scan period of Application Logic Execution Function

50 milliseconds – 1 second (in multiples of 10 milliseconds within this range)

Process Data I/O Function

For process data I/O, analog I/O modules and digital I/O modules are used. The table below lists I/O modules that SCSs can employ.

Table I/O Modules

Model	Type	Specifications
SDV144	Digital input module	16-channel, dry contact, module isolation
SDV521	Digital output module	4-channel, 24 V DC/2 A, module isolation
SDV526	Digital output module	4-channel, 100-120 V AC, module isolation
SDV531	Digital output module	8-channel, 24 V DC, module isolation
SDV53A	Digital output module	8-channel, 48 V DC, module isolation
SDV541	Digital output module	16-channel, 24 V DC, module isolation
SAI143	Analog input module	4 to 20 mA, 16-channel, module isolation
SAV144	Analog input module	1 to 5 V/1 to 10 V, 16-channel, module isolation
SAI533	Analog output module	4 to 20 mA, 8-channel, module isolation

Table Interference-free (*1) Communication Modules

Model	Type	Specifications
ALR111	Serial communication module	RS-232C communication interface module
ALR121	Serial communication module	RS-422/RS-485 communication interface module

*1: I/O modules not affecting the safety loop

Inter-SCS Safety Communication Function

When the inter-SCS safety communication function is employed, a safety loop up to SIL 3 (Safety Integrity Levels) can be constructed for multiple SCSs via the V net or Vnet/IP. This function assures the authenticity, quality, proper sequence and timeliness of data.

Specifications:

- The maximum number of SCSs with which safety communication is possible from one SCS is 16 (if one SCS performs bilateral communications, the number of SCS's is counted as 2).
- The maximum number of data items one SCS can transmit is 200.
- The maximum number of data one SCS can receive is 200.

For the compatibility of revision of Inter-SCS safety communication, please refer to "ProSafe-RS Safety Instrumented System Overview (for Vnet/IP)" (GS 32R01B10-21E) – "■ NETWORK SPECIFICATIONS" – "●Vnet/IP" – "Compatibility in Inter-SCS safety communication".

SCS Link Transmission

There are two types of SCS Link Transmission: SCS Link Transmission Safety Communication and SCS Global Switch Communication. SCS Link Transmission is SIL 3 safety communication function to notify more than one SCS of data. Data in one station is transmitted simultaneously to other SCS on regular basis. One station; moreover, can receive data sent by other stations and refer to it by application logic.

SCS Global Switch Communication makes it possible to refer the data transmitted between SCS and FCS. SCS Global Switch Communication is interference-free.

Communication Specifications

Communication range: limited to the same domain

Control bus: V net, Vnet/IP

Number of available stations: Maximum 63

(However, number of stations that can be referred to is different, depending on CPU as well as communication load)

Transmission cycle: fixed to 100 ms

Transmitted Data Reference/Setting

- Number of definition in input function block: Maximum 1000/1 SCS
- Number of definition in output function block: Maximum 128/1 SCS
- No limitation to the number of assignments per receiving station

Software Requirements

- SCS program: R1.03.00 or later
- SENG software: R1.03.00 or later
- SCS project: R1.03.00 or later
- CS 3000 system revision: R3.08.50 or later
- CENTUM VP system revision: R4.01 or later
- FCS system program: R3.08.50 or later

●External Communication Functions

The VP/CS 3000 integration, Modbus communication, sequence-of-events recorder (SOER), and diagnosis information collection functions are described below:

Scan period of External Connection Function

1 or 2 seconds.

VP/CS 3000 Integration Function

The VP/CS 3000 integration function allows the HIS of the VP/CS 3000 to control and monitor an SCS through a tag name interface as well as using a control tag.

When the tag name is defined using the VP/CS 3000 integration function, the HIS of the VP/CS 3000 can not only monitor the SCS, but also perform a maintenance override. An annunciator message with a priority level assigned can be sent from the SCS.

Table Types of SCS Data and Function Blocks for which Tag Name can be Assigned

Function category	Details	SCS definition	
		Function category	Functions
Internal variable	BOOL type	Internal variable	BOOL
	Integer-type (32-bit)	Internal variable	DINT
	REAL number-type (32-bit)	Internal variable	REAL
Input/Output variable	Discrete	I/O structure	IO_BOOL
	Analog	I/O structure	IO_REAL
Data Setting from external device	Data Setting (BOOL)	Function block	ECW_B
	Data Setting (integer)	Function block	ECW_I
	Data Setting (real number)	Function block	ECW_R
Analog input indication	Analog Input Function Block with Data Status	Function block	ANLG_S
	Analog Input	Function block	ANLGI
Velocity limit	Velocity Limit Alarm	Function block	VEL
Annunciator	Annunciator	Function block	ANN
	First-up Alarm Annunciator	Function block	ANN_FUP
Override from HIS	Override (BOOL)	Function block	OVR_B
	Override (integer)	Function block	OVR_I
	Override (real number)	Function block	OVR_R
	Override (discrete)	Function block	OVR_IB
	Override (analog)	Function block	OVR_IR
	Grouping Override (BOOL)	Function block	GOV_B
Manual operation	Grouping Override (discrete)	Function block	GOV_IB
	BOOL-Type Data Manual Operation Function Block with Two-Position Answerback	Function block	MOB_11
	BOOL-Type Data Manual Operation Function Block with Three-Position Answerback	Function block	MOB_21
	Auto-Reset BOOL-Type Data Manual Operation	Function block	MOB_RS
Password	Analog-Type Data Manual Operation	Function block	MOA
Subsystem	Password entry	Function block	PASSWD
	Subsystem Communication Input (BOOL)	Function block	SCI_B
	Subsystem Communication Input (integer)	Function block	SCI_I
	Subsystem Communication Input (real number)	Function block	SCI_R
	Subsystem Communication Output (BOOL)	Function block	SCO_B
	Subsystem Communication Output (integer)	Function block	SCO_I
	Subsystem Communication Output (real number)	Function block	SCO_R

Modbus Connection Function

SCS have a Modbus slave communication function as a standard function. External equipment acts as a Modbus master and can read and write SCS data.
 CFS9153 Modbus Communication Package is necessary so that SCS may become the Modbus master side. For details, refer to “Modbus Communication Package” (GS 32S05E10-21E).
 The Modbus connection function is interference-free.
 RS-422/RS-485 communication by the Modbus slave communication function supports only four-wire connection.

Sequence-of-events Recorder (SOER) Function

The SOER function is composed of an event collection sub-function, event storage sub-function, and time synchronization sub-functions. The HIS can display event information when an SOE viewer package is installed on the HIS.

- Event collection and storage sub-function
 Event information is collected and stored in the digital input module or in the CPU module of an SCS. Time stamp resolution of events collected by a digital input module is 1 ms. Other events are collected by CPU module and their time stamp resolution is SCS scan period.
- Event information to be collected
 According to the user definition, SCSs can collect the event information listed in the table below.

Information to be collected	Trigger for event collection and location for collection
Digital input	Changes in the value of data input into the digital input module are set to act as a trigger. This trigger instructs the digital input module to collect events. Whether or not to perform SOE collection can be specified for each channel. (*1)(*3)
Digital output	Changes in the value of data output to the digital output module are set to act as a trigger. This trigger instructs the CPU to collect events. Whether or not to perform SOE collection can be specified for each channel. (*2)(*3)
Analog input	The analog input function block determines the level of the data value for event collection. (*4)
Application logic variable	Each of BOOL-type, INTEGER-type, and REAL-type SOE event collection function blocks collects events. (*4)

- *1: If the digital input module is dual-redundant, the module with control authority collects events.
- *2: If the output channel is abnormal (the data status is BAD), events are not collected.
- *3: A channel comment (a string composed of a maximum of 32 single-byte characters or 16 double-byte characters) needs to be set.
- *4: A sequential event identifier (a string composed of a maximum of 32 single-byte characters or 16 double-byte characters) needs to be set to the input terminal ID in a function block. Collect analog output events by a function block for constant SOE event collection.

- Storage of Event Information
 Event information is stored in an event information file in an SCS. Such event information can be seen from multiple SOE viewers.
 There are two kinds of event information files: an event log file and a trip signal file. The event log file contains collected event data. The trip signal file contains events before and after a trip signal that has been specified by a user.

Table Event Information File Specification

	Event log file (*1)	Trip signal file (*2)(*3)
Maximum number of events	15000 events	1500 events (500 before signal generation and 1000 after signal generation)
Maximum number of files	1	2

- *1: A diagnosis information message is transmitted to the user every 12000 events.
- *2: Upon completion of trip signal file collection, a diagnosis information message is transmitted.
- *3: If the number of events is fewer than 1000 in 30 minutes after the signal is generated, the creation of a trip signal file is terminated. Then a diagnosis information message is transmitted.

Diagnosis Information Collection Function

An SCS transmits a diagnosis information message when it detects an abnormal condition. The transmitted message is stored in the memory of an SCS as diagnosis information. Based on the message contents, information on the time, location, type, etc., of the abnormality can be obtained. An SCS can store up to 5000 pieces of information.

● **Test Function**

There are two kinds of test in the test function. One is designed to debug applications when FCS simulator, SCS simulator and HIS virtual function operate on the PC and the PC is virtually isolated from V net or Vnet/IP. The other is a target test by using actual SCS.

For VP/CS 3000 test function, please refer to “Test Function” (GS 33M10D50-40E, GS 33Q04N10-31E).

● **SCS Simulator**

SCS simulator has SCS system software operating in SCS operate in the PC. It makes possible for the machine to communication with virtual HIS, FCS simulator and SCS simulator on other PCs. It also has an interface function (Exatif CS 3000) to plant training system used for operator training.

● **Connect to Plant Expert System (using Exatif Package)**

V net or Vnet/IP interface for plant expert system environment is supported.

Standard system configuration is required for more continuous, stable operation than that for test functions.

For details, please refer to “Expanded Test Functions, FCS Simulator Package, HIS Simulator Package” (GS 33M10D60-40E, GS 33Q04N11-31E).

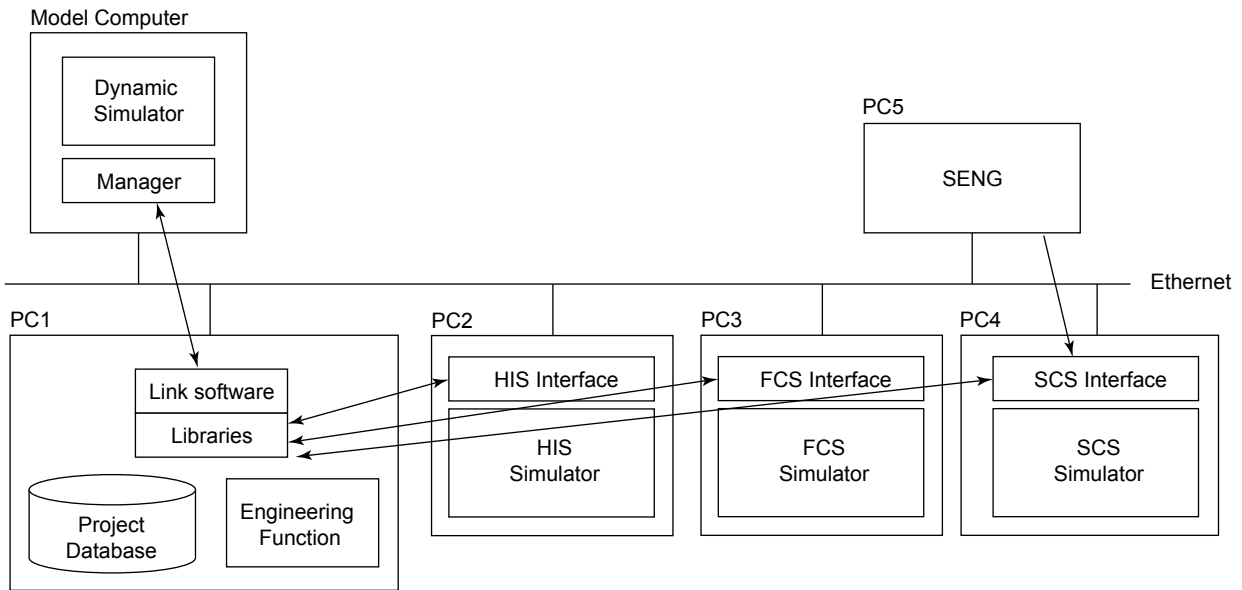

PC1: Engineering Function PC2: HIS + HIS Simulator PC3: FCS Simulator PC4: SCS Simulator PC5: SENG

F06.ai

Figure Example of System Configuration

Table Package required for each PC on Plant Expert System

Product	Package	PC1	PC2	PC3	PC4	PC5
ProSafe-RS	CHS5100 Safety System Generation and Maintenance Package					X
	CHS5200 CENTUM VP/CS 3000 Integration Engineering Package					X
CENTUM VP / CS 3000 (*1)	LHS1100 Standard Operation and Monitoring Function	-	X	-		X
	LHS5100 Standard Builder Function	X	-	-		
	LHS5420 Test Function (*2)	X	-	-		
	LHS5425 Expanded Test Function Package	X	-	-		
	LHS5426 FCS Simulator Package	-	-	X	X	
LHS5427 HIS Simulator Package	-	X	-		X	
Exatif (*3)		X	X	X	X	-

- X: Required
- : Not Required
- *1: CENTUM VP R4.01 or later, or CS 3000 R3.08.50 or later
- *2: Including the FCS simulator and HIS simulator
- *3: Install the package in each PC

■ APPLICATION CAPACITY

The capacity of the safety control functions of an SCS is called the application capacity. The application capacity of an SCS is as follows:

Category	Item	Maximum capacity
I/O-related items	Number of I/O nodes	9
	Number of slots	8 6 (when 2 ESB bus coupler modules are mounted)
	Number of communication modules	6 (2 modules as slaves and 4 modules as masters)
	Number of I/O points	1000 (*2)
	Number of subsystem communication data items	500 (maximum communication data items per SCS)
Application logic	Number of POUs (*1)	500
	Number of variables	1000 I/O variables (*2) 3000 internal variables (*2)
Inter-SCS Safety Communication	Number of produced data	200
	Number of consumed data	200
SCS Link Transmission	Number of transmitted data	128
	Number of received data	1000
VP/CS 3000 integration function	Number of analog input blocks	total 1800
	Number of velocity alarm blocks	
	Number of override blocks	
	Number of password blocks	
	Manual operation function block	
	Number of words contained in communication I/O data	500
	Number of annunciators	1000

*1: POU (Program Organization Unit) is a generic term indicating programs, user defined function blocks, and user defined functions.

*2: The numbers are just for reference.

■ MODELS AND SUFFIX CODES

Model	Description
CFS1100	Safety Control Functions Package

Note: A purchase order for the CFS1100 can be placed using the Model and Suffix Codes of SSC50□/SSC10□. A separate order is not necessary.

■ OPERATING ENVIRONMENT

CFS1100 Safety Control Functions Package works by the following safety control units: SSC50S, SSC50D, SSC10S and SSC10D.

■ TRADEMARKS

- CENTUM and ProSafe are registered trademarks of Yokogawa Electric Corporation.
- Other company and product names appearing in this document are trademarks or registered trademarks of their respective holders.