

General Specifications

GS 32S04D10-21E

Model CHS5200
CENTUM VP/CS 3000
Integration Engineering
Package



■ GENERAL

The CHS5200 CENTUM VP/CS 3000 Integration Engineering Package runs on a safety engineering PC (SENG) to integrate ProSafe-RS and the CENTUM VP/CS 3000 (hereinafter called the VP/CS 3000).

■ FUNCTION OVERVIEW

With this package, users can configure a system that integrates ProSafe-RS and the VP/CS 3000, as illustrated below.

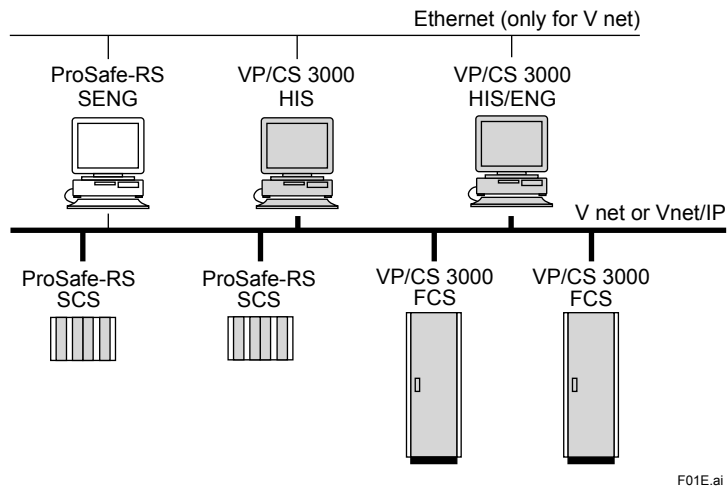

F01E.ai

Figure Example of Configuration of ProSafe-RS and VP/CS 3000 Integration System

In the ProSafe-RS and VP/CS 3000 integrated system, access can be made from a human interface station (HIS) or field control station (FCS) to a safety control station (SCS) to perform the following:

- Using tag names, manipulate and monitor SCS data from the HIS through the same interface as that for the VP/CS 3000 FCS, and gain access to SCS data from the VP/CS 3000 FCS.
- In the Process Alarm window of the HIS, manage the generation of/recovery from process alarms or annunciator alarms detected by the SCS.
- In the System Alarm window of the HIS, monitor system alarms generated from the SCS.
- In the SCS Status window of the HIS, show the status of the SCS.

■ FUNCTIONAL SPECIFICATIONS

● Package Functions

The VP/CS 3000 integration engineering package has the functions summarized in the following table.

Function	Description
Common definitions for integration with the VP/CS 3000 (*1)	In the Properties window of an SCS project, SCS parameters necessary for integration with the VP/CS 3000 are defined on an SCS-by-SCS basis.
Alarm priority definition	Using the Alarm Priority builder, the alarm output format and alarm action are defined on a priority-of-alarm basis to cope with the generation of/recovery from SCSs' process alarms to be shown on the HIS on an SCS-by-SCS basis.
Alarm processing definition	Import alarm processing table defined in VP/CS 3000.
Annunciator message definition	Using the Tag Name builder, the content of annunciator messages to be shown on the HIS on an SCS-by-SCS basis is defined.
Tag name definition	Using the Tag Name builder, tag names are assigned and parameters are defined to application logic variables and function blocks of the SCS which is accessed from the FCS of the VP/CS 3000 or manipulated/monitored from the HIS on an SCS-by-SCS basis.

*1: The SCS parameters must be defined separately on the VP/CS 3000 side and the tag list generation function be started.

The following table summarizes the capacity of function blocks that can be operated/monitored for each SCS in an integrated VP/CS 3000 system configuration.

Name	Function Block/Element Name	Maximum Number of Blocks
ANLG_S/ANLGI	Analog input block	Total 1800
VEL	Velocity (rate-of-change) alarm block	
OVR_B/OVR_I/OVR_R/OVR_IR/OVR_IB/ GOV_B/GOV_IB	Override block	
PASSWD	Password block	
MOB_11/MOB_21/MOB_RS/MOA	Manual loader block	
ANN	Annunciator message	1000

● Types of SCS Data and Function Blocks for which Tag Names can be Assigned

The SCS variable data and function blocks assigned tag names are included in the tag monitoring points.

The following table summarizes the types of SCS variable data and function blocks for which tag names can be assigned.

Type	Description
BOOL	BOOL-type variable
DINT	Integer-type variable
REAL	REAL number-type variable
ANLG_S	Analog Input Function Block with Data Status
ANLGI	Analog Input
VEL	Velocity Limit Alarm
ANN	Annunciator
ANN_FUP	First-up Alarm Annunciator
IO_REAL	Real-number analog I/O variable
IO_BOOL	BOOL-type contact I/O variable
GOV_B	Grouping Override (BOOL)
GOV_IB	Grouping Override (discrete)
OVR_B	BOOL-Type Data Override
OVR_I	Override (integer)
OVR_R	Override (real number)
OVR_IB	Override (discrete)
OVR_IR	Override (analog)
PASSWD	Password entry
ECW_B	Data Setting (BOOL)
ECW_I	Data Setting (integer)
ECW_R	Data Setting (real number)
SCI_B	Subsystem Communication Input (BOOL)
SCI_I	Subsystem Communication Input (integer)
SCI_R	Subsystem Communication Input (real number)
SCO_B	Subsystem Communication Output (BOOL)
SCO_I	Subsystem Communication Output (integer)
SCO_R	Subsystem Communication Output (real number)
MOB_11	BOOL-Type Data Manual Operation Function Block with Two-Position Answerback
MOB_21	BOOL-Type Data Manual Operation Function Block with Three-Position Answerback
MOB_RS	Auto-Reset BOOL-Type Data Manual Operation
MOA	Analog-Type Data Manual Operation

■ SYSTEM REQUIREMENTS

Refer to the GS “ProSafe-RS Safety Instrumented System Overview.”

■ MODELS AND SUFFIX CODES

		Description
Model	CHS5200	CENTUM VP/CS 3000 Integration Engineering Package [Medium model: CHSKM02-V11]
Suffix Codes	-V	Software license
	1	Always 1
	1	English version

■ OTHER CAUTIONARY NOTES

For details on Windows general-purpose application software that can run on the SENG, contact your Yokogawa Electric sales office.

■ ORDERING INFORMATION

Specify the model and suffix codes.

■ TRADEMARKS

- CENTUM and ProSafe are registered trademarks of Yokogawa Electric Corporation.
- Windows is a registered trademark of Microsoft Corporation in the USA and other countries.
- Other company and product names appearing in this document are trademarks or registered trademarks of their respective holders.