

General Specifications

Model CHS5700 FAST/TOOLS Integration Engineering Package



GS 32R04D20-21E

■ GENERAL

This package runs on the safety engineering PC (SENG) and enables the integration between ProSafe-RS and FAST/TOOLS. This package is used for configuring a system which monitors and controls oil wells and oil pipe lines dotted in wide area. If this package is used, ProSafe-RS can not be integrated with CENTUM VP/CS3000 (hereinafter called VP/CS 3000).

■ FUNCTION OVERVIEW

With this package, users can configure a system that integrates ProSafe-RS and FAST/TOOLS, as illustrated below.

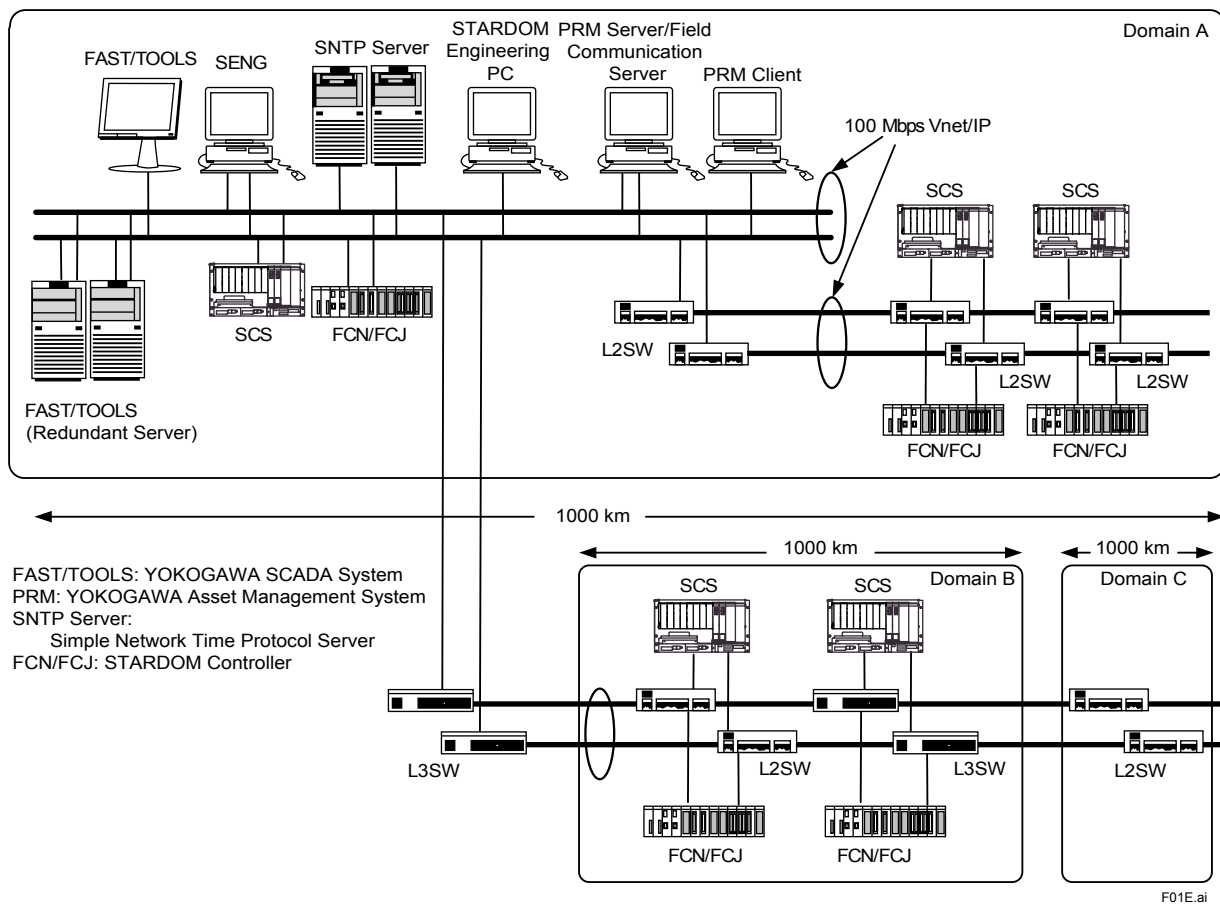

Figure Example of Configuration of ProSafe-RS and FAST/TOOLS Integration System

In ProSafe-RS and FAST/TOOLS integrated system, functions described below are available.

- SCS can be operated and monitored from FAST/TOOLS
 - Operation and monitoring of SCS using Tag Name
 - Detecting Process Alarms and System Alarms
 - SCS status display
 - Managing SCS annunciators (Alarm and recovery)
- Dual redundant Ethernet TCP/IP communication can be configured using a pair of Vnet/IP open networks.
- The distance between stations of the same Vnet/IP domain can be extended.

For the specification of FAST/TOOLS, refer to FAST/TOOLS R9.02 (GS 50A01A10-01E).

When integrating ProSafe-RS and FAST/TOOLS, please be sure to separate physically Vnet/IP from CENTUM VP/CS 3000 integrated system.

The physical separation means the two networks should not be linked either directly or through a network switch or a router.

■ FUNCTION SPECIFICATION

● Package Function

FAST/TOOLS Integration Engineering Package includes functions described below.

Function	Description
Domain Properties setting	Setting Wide-area or Standard
Annunciator Message definition	The annunciator messages of each SCS to be shown on the FAST/TOOLS is defined on Tag Name builder.
Tag Name definition	The application logic variables and function blocks of each SCS to be accessed by FAST/TOOLS need to be defined with tag names and parameters on Tag Name builder.

The following table summarizes the maximum number of function blocks that can be operated/monitored for each SCS in a FAST/TOOLS integrated system configuration.

Name	Function Block/Element Name	Maximum Number	
		SSC60□	SSC50□
Safety Control Station			
ANLG_S/ANLGI	Analog Input Block	Total 2700	Total 1800
VEL	Velocity (rate-of-change) Alarm Block		
ANN/ANN_FUP	Annunciator Message	2000	1000

● System Configuration

By changing domain properties, the area of a Vnet/IP domain can be expanded as follows;

Connectable Control Bus: Vnet/IP

Number of connectable domains: 31

Number of connectable stations in a domain: 64

Number of connectable stations: 1984 (*1)

Number of hierarchy: 16

*1: Number of nodes connected to Vnet/IP must be decided after confirming the validity of communication load.

Specification in Vnet/IP domain

Standard

Transmission speed: 1 Gbps (The maximum distance between stations is 40 km. The maximum transmission delay is 3 ms.)

Wide-area

Transmission speed: Minimum of 100 Mbps (The maximum distance between stations is 1000 km. The maximum transmission delay is 40 ms.)

● **Types of SCS Data and Function Blocks for which Tag Names can be assigned**

The following table summarizes the types of SCS variable data and function blocks for which tag names can be assigned.

Type	Description
BOOL	BOOL-type variable
DINT	Integer variable
REAL	Real-number variable
ANLG_S	Analog Input Function Block with Data Status
ANLGI	Analog Input
VEL	Velocity Limit Alarm
ANN	Annunciator
ANN_FUP	First-up Alarm Annunciator
IO_REAL	Real-number analog input variable
IO_BOOL	BOOL-type contact I/O variable
ECW_B	BOOL-Type Data External Communication
ECW_I	INTEGER-Type Data External Communication
ECW_R	REAL-Type Data External Communication
SCI_B	BOOL-Type Subsystem Communication Input
SCI_I	INTEGER-Type Subsystem Communication Input
SCI_R	REAL-Type Subsystem Communication Input
SCO_B	BOOL-Type Subsystem Communication Output
SCO_I	INTEGER-Type Subsystem Communication Output
SCO_R	REAL-Type Subsystem Communication Output

When ProSafe-RS is integrated with FAST/TOOLS, the following Function Blocks can not be used. If any of them are used, an error occurs during the build operation.

- Override (OVR_B, OVR_I, OVR_R, OVR_IB, OVR_IR, GOV_B, GOV_IB)
- Password (PASSWD)
- Manual Operation (MOB_21, MOB_11, MOB_RS, MOA)

■ **SYSTEM REQUIREMENTS**

Refer to GS 32R01B10-21E “ProSafe-RS Safety Instrumented System Overview.”

● **Software**

FAST/TOOLS R9.02 or later

■ MODEL AND SUFFIX CODE

		Description
Model	CHS5700	FAST/TOOLS Integration Engineering Package [Medium model: CHSKM02-V11]
Suffix Code	-V	Software license
	1	Always 1
	1	English version

■ ATTENTION

As for Windows general-purpose application software that can run on SENG, contact your Yokogawa Electric sales office.

■ ORDERING INFORMATION

Specify Model and Suffix Code.

■ TRADEMARKS

- ProSafe, CENTUM, Vnet/IP and STARDOM are registered trademarks of Yokogawa Electric Corporation.
- Windows is a registered trademark of Microsoft Corporation in USA and in other countries.
- Other company names and product names in this document are trademarks or registered trademarks of their respective holders.