

General Specifications

GS 34P02Q43-01E

Models TAS40, TAS50
MIL Connector Terminal Blocks
Models KMS40, KMS50
MIL Connector Cables



■ GENERAL

This General Specification (GS) sheet describes MIL connector cables and MIL connector terminal blocks enabling connections to field control node (FCN) autonomous controllers.

● MIL Connector Cables (KMS40 and KMS50) / MIL Connector Terminal Blocks (TAS40 and TAS50)

These MIL connector cables and connector terminal blocks are MIL connector-equipped (MIL-C-83503-compliant) cables and connectors. Using these cables and terminal blocks makes it possible to reduce wiring connections for switchboard design.

Note: KMS40 should be used with TAS40.
KMS50 should be used with TAS50.

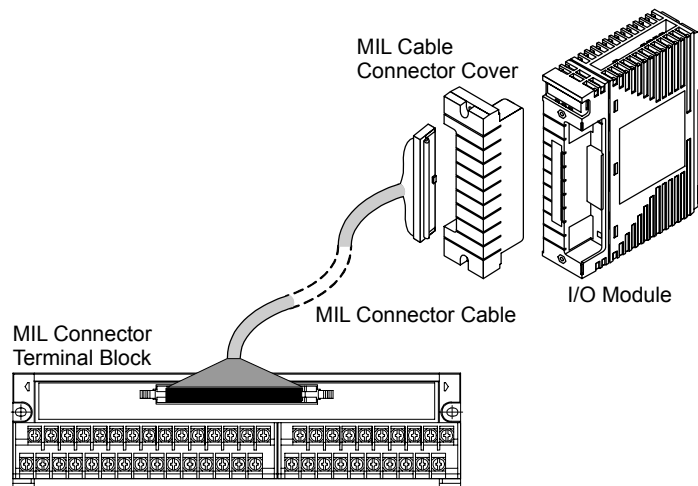

F01E.ai

Figure Example of Connecting I/O Modules to a MIL Connector Cable

● **Combination of I/O Modules with MIL Connector Cable / MIL Connector Terminal Block**

I/O modules can be used in combination with MIL connector cables and MIL connector terminal blocks, as given below.

Table Combinations of I/O Modules

Model		Module name	MIL connector terminal block (*1)	
			Cable	Terminal block
CPU Module	NFCP050	CPU Module for FCN-RTU (1 to 5V Input: 12-Channel, 4 to 20 mA Output: 2-Channel, Status input: 16-Channel, Status output: 16-Channel, Pulse input: 2-Channel, Non-Isolated)	KMS40 (*3)	TAS40 (*3)
Analog I/O Modules	NFAI141	Analog Input Module (4 to 20 mA, 16-Channel, Non-Isolated)	KMS40	TAS40
	NFAV141	Analog Input Module (1 to 5 V: differential input, 16-Channel, Non-Isolated)	KMS40	TAS40
	NFAV142	Analog Input Module (-10 V to +10 V, 16-Channel, Non-Isolated)	KMS40	TAS40
	NFAV144	Analog Input Module (-10 V to +10 V, 16-Channel, Isolated)	KMS40	TAS40
	NFAI841	Analog I/O Module (4 to 20 mA Input, 4 to 20 mA Output, 8-Channel Input/8-Channel Output, Non-Isolated)	KMS40	TAS40
	NFAB841	Analog I/O Module (1 to 5 V input: differential input, 4 to 20 mA Output, 8-Channel Input/8-Channel Output, Non-Isolated)	KMS40	TAS40
	NFAV542	Analog Output Module (-10 V to +10 V, 16-Channel, Non-Isolated)	KMS40	TAS40
	NFAV544	Analog Output Module (-10 V to +10 V, 16-Channel, Isolated)	KMS40	TAS40
	NFAI143	Analog Input Module (4 to 20 mA, 16-Channel, Isolated)	KMS40	TAS40
	NFAI543	Analog Output Module (4 to 20 mA, 16-Channel, Isolated)	KMS40	TAS40
	NFAT141	Thermocouple/mV Input Module (*1) (16-Channel, Isolated)	KMS40 (*2)	TAS40 (*2)
	NFAI135	Analog Input Module (4 to 20 mA, 8-Channel, Isolated Channels)	KMS40	TAS40
	NFAI835	Analog I/O Module (4 to 20 mA, 4-Channel Input/4-Channel Output, Isolated Channels)	KMS40	TAS40
	NFAP135	Pulse Input Module (8-Channel, Pulse Count, 0 to 10 kHz, Isolated Channels)	KMS40	TAS40
NFAF135	Frequency Input Module (8-Channel, contact ON/OFF, Voltage pulse, 0.1 Hz to 10 kHz, Isolated Channels)	KMS40	TAS40	
Digital I/O Modules	NFDV151	Digital Input Module (32-Channel, 24 V DC)	KMS50	TAS50
	NFDV161	Digital Input Module (64-Channel, 24 V DC)	KMS50 (*3)	TAS50 (*3)
	NFDV532	Pulse Width Output Module (4-channel : Up Pulse/Down Pulse, 24 V DC, Isolated)	KMS50	TAS50
	NFDV551	Digital Output Module (32-Channel, 24 V DC)	KMS50	TAS50
	NFDV561	Digital Output Module (64-Channel, 24 V DC)	KMS50 (*3)	TAS50 (*3)

*1: KMS40 should be used with TAS40. KMS50 should be used with TAS50.

*2: NFAT141 can be used for a mV input only.

*3: Requires two MIL connector cables and MIL connector terminal blocks each.

● **Securing MIL Connector Cable**

- After connecting the cable to the I/O module, secure it with the MIL cable connector cover (NFCCC01) (excluding NFDV161 and NFDV561).
- When connecting the MIL connector cable to the NFDV161 or NFDV561, secure it with a connector lock lever.

■ FUNCTION SPECIFICATIONS

● MIL Connector Terminal Block

Item	Specifications	
	TAS40	TAS50
Model		
Connecting Channels	40	50
MIL connector cable that can be connected	KMS40 or equivalent	KMS50 or equivalent
Rated voltage	125 V	
Rated current	1 A	
Applicable cable size	Max 2 mm ²	
Screw of terminal block	M3.5	
Tightening torque	1.0 to 1.3 N·m	
Applicable terminal	Solderless terminals, 7-mm wide or less	
Connector used	HIF3BA-40PA-2.54DSA (MIL-C-83503 -compliant)	HIF3BA-50PA-2.54DSA (MIL-C-83503 -compliant) (*1)
Mounting	35-mm wide DIN rail, screw mounted	
Mounting Screw (For screw mounting)	Two M4 screws	
Color	Gray	Gray
Weight	255g	330g
Ambient temperature	-40 to 70 °C	
Ambient humidity	10 to 90 % RH (non-condensing)	
Operating atmosphere	Must be free of corrosive gases or heavy dust.	
Altitude	3000m or less	

*1: With two incorrect-insertion prevention keys

● MIL Connector Cable

Item	Specifications	
	KMS40	KMS50
Model		
MIL connector terminal block that can be connected	TAS40	TAS50
Cable length	0.5m, 1.0m, 1.5m, 2.0m, 2.5m, 3.0m, 4.0m, 5.0m, 6.0m, 7.0m, 8.0m, 9.0m, 10.0m, 15.0m, 20.0m, 25.0m	
Withstanding voltage	Between signal and shield: 500 V AC,	

■ SCHEMATIC DIAGRAM

● MIL Connector Terminal Block: TAS40

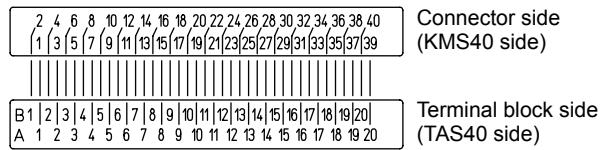

F02E.ai

Note: The terminal arrangement on the terminal block side coincides with the connector terminal arrangement on the module side.

● MIL Connector Terminal Block: TAS50

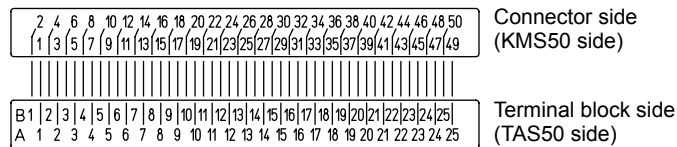

F03E.ai

Note: The terminal arrangement on the terminal block side coincides with the connector terminal arrangement on the module side.

EXTERNAL DIMENSIONS

MIL Connector Terminal Block: TAS40

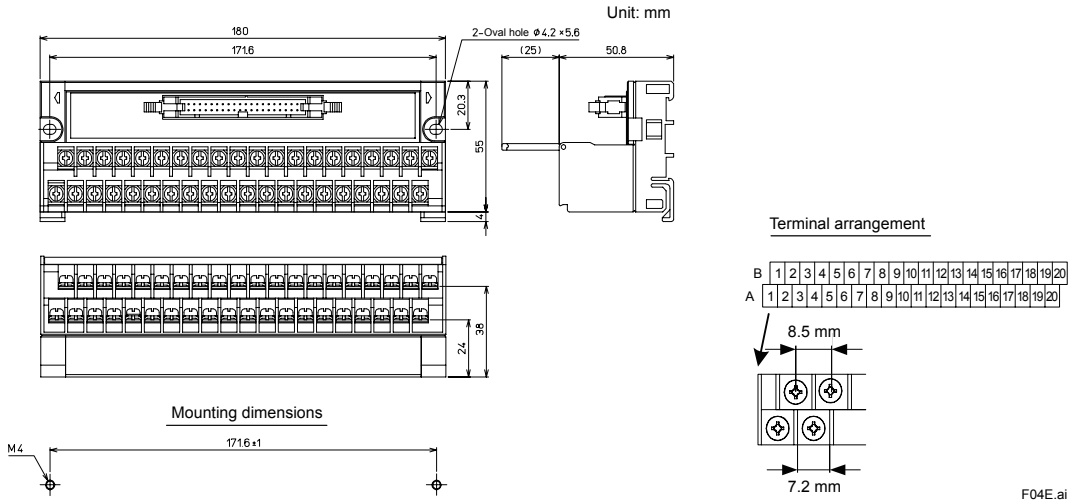

MIL Connector Terminal Block: TAS50

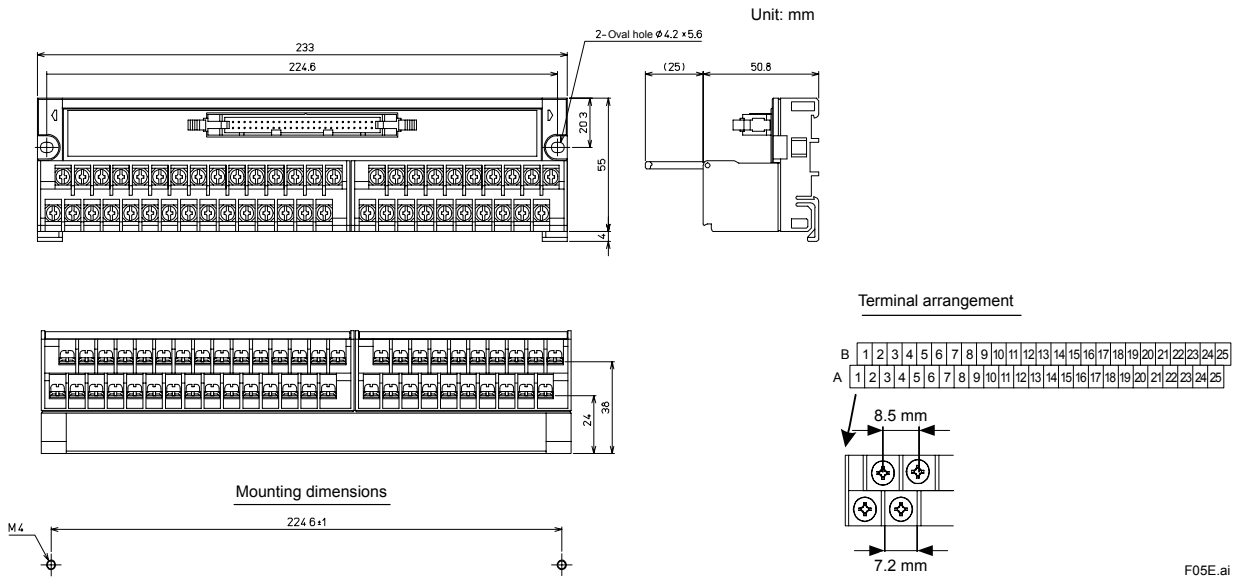

● MIL Connector Cable: KMS40

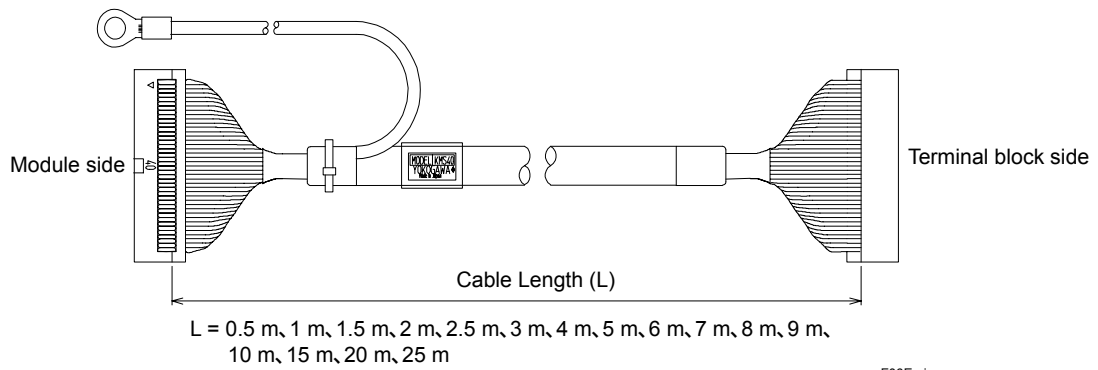

● MIL Connector Cable: KMS50

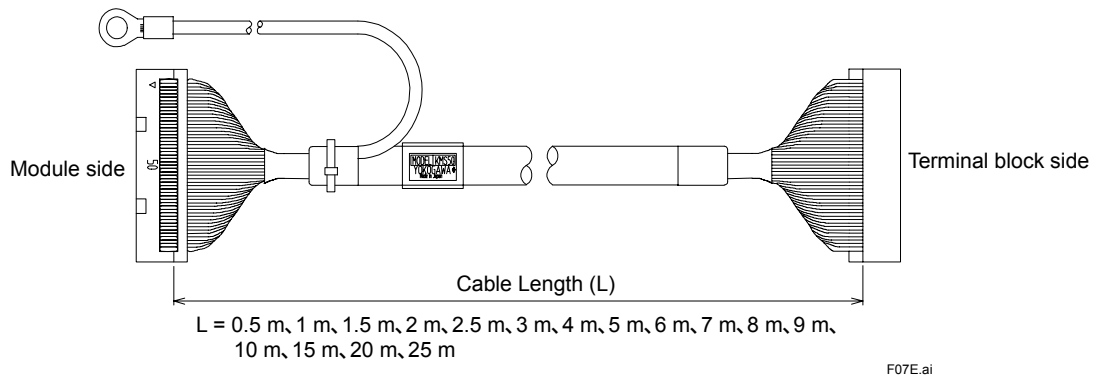

■ SIGNAL ASSIGNMENT

● Analog I/O Module ↔ TAS40

Pin No. of I/O Module	Screw Terminal Marking on MIL Connector Terminal Block	Pin No. of I/O Module	Screw Terminal Marking on MIL Connector Terminal Block
40	B20	39	A20
38	B19	37	A19
36	B18	35	A18
34	B17	33	A17
32	B16	31	A16
30	B15	29	A15
28	B14	27	A14
26	B13	25	A13
24	B12	23	A12
22	B11	21	A11
20	B10	19	A10
18	B9	17	A9
16	B8	15	A8
14	B7	13	A7
12	B6	11	A6
10	B5	9	A5
8	B4	7	A4
6	B3	5	A3
4	B2	3	A2
2	B1	1	A1

● Digital I/O Modules ↔ TAS50

Pin No. of I/O Module	Screw Terminal Marking on MIL Connector Terminal Block	Pin No. of I/O Module	Screw Terminal Marking on MIL Connector Terminal Block
50	B25	49	A25
48	B24	47	A24
46	B13	45	A23
44	B22	43	A22
42	B21	41	A21
40	B20	39	A20
38	B19	37	A19
36	B18	35	A18
34	B17	33	A17
32	B16	31	A16
30	B15	29	A15
28	B14	27	A14
26	B13	25	A13
24	B12	23	A12
22	B11	21	A11
20	B10	19	A10
18	B9	17	A9
16	B8	15	A8
14	B7	13	A7
12	B6	11	A6
10	B5	9	A5
8	B4	7	A4
6	B3	5	A3
4	B2	3	A2
2	B1	1	A1

■ MODELS AND SUFFIX CODES

MIL Connector Terminal Block

		Description
Model	TAS40	MIL Connector Terminal Block (40- pole plug type, M3.5)
	TAS50	MIL Connector Terminal Block (50- pole plug type, M3.5)
Suffix Codes	-0N	Standard type

MIL Connector Cable

		Description
Model	KMS40	MIL Connector Cable (40-pole plug type)
	KMS50	MIL Connector Cable (50-pole plug type)
Suffix Codes	-005	Cable length 0.5m
	-010	Cable length 1.0m
	-015	Cable length 1.5m
	-020	Cable length 2.0m
	-025	Cable length 2.5m
	-030	Cable length 3.0m
	-040	Cable length 4.0m
	-050	Cable length 5.0m
	-060	Cable length 6.0m
	-070	Cable length 7.0m
	-080	Cable length 8.0m
	-090	Cable length 9.0m
	-100	Cable length 10.0m
	-150	Cable length 15.0m
	-200	Cable length 20.0m
-250	Cable length 25.0m	

MIL Cable Connector Cover

		Description
Model	NFCCC01	MIL Cable Connector Cover

■ ORDERING INFORMATION

Specify models and suffix codes.

■ RELATED DOCUMENTS

- GS 34P02Q13-01E: FCN-RTU Low Power Autonomous Controller Hardware
- GS 34P02Q30-01E: Field Connection Specifications
- GS 34P02Q31-01E: Analog I/O Modules
- GS 34P02Q35-01E: Digital I/O Modules

■ TRADEMARK

- STARDOM is a trademark of Yokogawa Electric Corporation.
- Other company names and product names in this document are registered trademarks or trademarks of their respective holders.