

General Specifications

Model ALE111 Ethernet Communication Module (for N-IO/FIO)



GS 33J60G11-01EN

[Release 6]

■ GENERAL

This document describes about Model ALE111 Ethernet Communication Module (for N-IO/FIO) that a field control station (FCS) uses to perform Ethernet communication with subsystems such as FA-M3. This Ethernet communication module can be mounted on field control units (AFV30□, AFV40□, A2FV50□, and A2FV70□), ESB bus node unit (ANB10□) and optical ESB bus node unit (ANB11□).

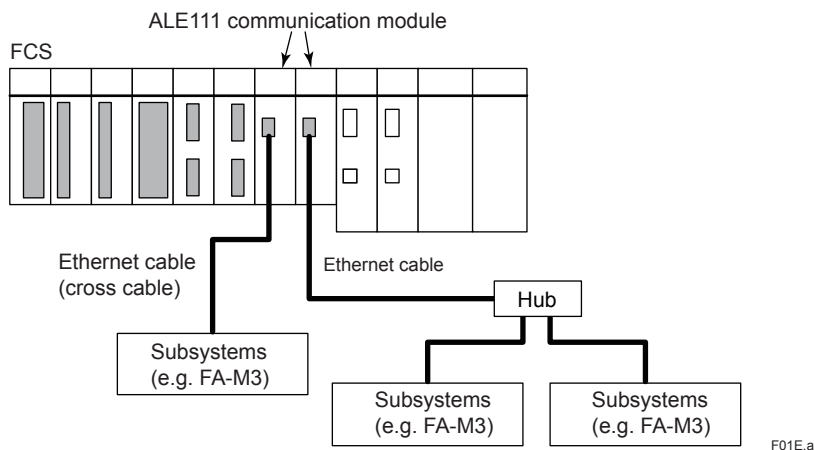

Figure A Configuration Sample of Ethernet Communication Module

■ STANDARD SPECIFICATIONS

The Ethernet communication module (ALE111) hardware specifications are as shown below.

Table Ethernet communication module hardware specifications

Item	Specifications
Physical layer interface	IEEE802.3 10BASE-T
Connection method	Point-to-point
Connector	RJ-45
Transmission method	Half-duplex
Transmission speed	10 Mbps
Transmission route	100 ohm twisted-pair cable (not shielded)
Transmission distance	1 segment, 100 m (in between FCS and subsystems, or HUB and subsystems)
Installation method	Mounted on ANB10□, ANB11□, AFV30□, AFV40□, A2FV50□, or A2FV70□
No. of ports	One port
Media access control	CSMA/CD
Communication functions	Communications with FA-M3, Modbus, MELSEC, YFGW, DARWIN/DAQSTATION/SMARTDAC+, and PLC-5/SLC500
Current consumption	0.5 A
Weight	Approx. 0.30 kg

An FCS collects data from subsystems or sets data with control calculations to subsystems using the builder functions by way of Ethernet communication modules. Only one communication function is established for each communication module, and multiple communication functions cannot be performed.

■ OPERATING ENVIRONMENT

Hardware Requirements

The Ethernet communication module runs on the following FCS.

AFV30S, AFV30D, AFV40S, AFV40D, A2FV50S, A2FV50D, A2FV70S, S2FV70D

Software Requirements

The Ethernet communication module runs on the control functions of the following FCS.

VP6F1700 Control Function for Field Control Station: for AFV30□/AFV40□
 VP6F1800 Control Function for Field Control Station: for A2FV50□
 VP6F1900 Control Function for Field Control Station: for A2FV70□

Engineering Requirements

Works on VP6E5100 Standard Builder Function.

■ INSTALLATION ENVIRONMENT

VP6F1700 Control Function for Field Control Station (for AFV30□/AFV40□)

No. of ALR111, ALR121, ALE111, ALP111, ALP121, A2LP131, AGS813, and AGP813 modules	Max. 32 units/FCS (Max. 16 pairs for dual-redundant operation) (*1)
No. of ALF111 modules	Max. 64 units/FCS (Max. 32 pairs for dual-redundant operation)
No. of all the communication modules	Max. 64 modules/FCS (*1) (*2)
I/O data capacity for communication	1000 word/ALE111
No. of communication definition	128 definitions/ALE111
No. of communication functions	Max. 8 types/FCS (*1) (*3)
Communication I/O data capacity	Max. 8000 words/FCS (incl. data from other communication function)

*1: ALP111 and ALP121 cannot be mounted on the same FCS together.

*2: This is the sum of ALR111, ALR121, ALE111, ALF111, ALP111, ALP121, A2LP131, AGS813, and AGP813 modules.

*3: This is the sum of communication functions of ALR111, ALR121, ALE111, ALP111, ALP121, and A2LP131. Note that multiple communication functions cannot be performed on a single ALE111 module.

VP6F1800 Control Function for Field Control Station (for A2FV50□)

No. of ALR111, ALR121, ALE111, ALP121, and A2LP131 modules	Max. 32 units/FCS (Max. 16 pairs for dual-redundant operation)
No. of ALF111 modules	Max. 64 units/FCS (Max. 32 pairs for dual-redundant operation)
No. of all the communication modules	Max. 64 modules/FCS (*1)
I/O data capacity for communication	1000 word/ALE111
No. of communication definition	128 definitions/ALE111
No. of communication functions	Max. 8 types/FCS (*2)
Communication I/O data capacity	Max. 8000 words/FCS (incl. data from other communication function)

*1: This is the sum of ALR111, ALR121, ALE111, ALF111, ALP121, and A2LP131 modules.

*2: This is the sum of communication functions of ALR111, ALR121, ALE111, ALP121, and A2LP131. Note that multiple communication functions cannot be performed on a single ALE111 module.

VP6F1900 Control Function for Field Control Station (for A2FV70□)

No. of ALR111, ALR121, ALE111, ALP121, and A2LP131 modules	Max. 32 units/FCS (Max. 16 pairs for dual-redundant operation)
No. of ALF111 modules	Max. 64 units/FCS (Max. 32 pairs for dual-redundant operation)
No. of all the communication modules	Max. 64 modules/FCS (*1)
I/O data capacity for communication	1000 word/ALE111
No. of communication definition	128 definitions/ALE111
No. of communication functions	Max. 8 types/FCS (*2)
Communication I/O data capacity	Max. 8000 words/FCS (incl. data from other communication function)

- *1: This is the sum of ALR111, ALR121, ALE111, ALF111, ALP121, and A2LP131 modules.
- *2: This is the sum of communication functions of ALR111, ALR121, ALE111, ALP121, and A2LP131. Note that multiple communication functions cannot be performed on a single ALE111 module.

■ SUBSYSTEM COMMUNICATIONS

The Ethernet communication module communicates with subsystems at the specified intervals and stores the subsystem data in the communication modules' I/O image. FCS accesses the communication module asynchronously from them, and refers to or sets the I/O image. This enables FCS to use the subsystem data through the I/O terminals of the function block in the same way as the general analog and digital I/O signals.

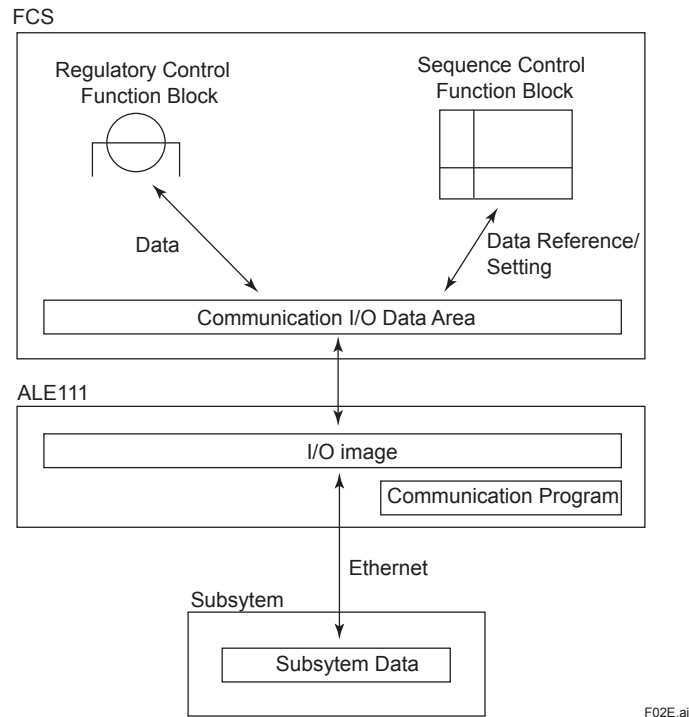

Figure Flow of Data in a Subsystem

■ COMMUNICATION FUNCTIONS

● FA-M3 Communication

Connected device :FA-M3 Ethernet interface module: F3LE01-5T, F3LE01-0T, F3LE11-0T, F3LE12-0T, F3LE01-1T, F3LE11-1T, F3LE12-1T

Sequence CPU Module (*1): F3SP66, F3SP67, F3SP71, F3SP76

Connection method : Ethernet connection via a hub. Or, with a 10BASE-T connection, a crossover cable can also be used for a peer-to-peer connection without a hub.

Applicable device : FA-M3 CPU module: F3SP21, F3SP25, F3SP35, F3SP28, F3SP38, F3SP53, F3SP58
FA-M3 CPU module (with network functions): F3SP66, F3SP67, F3SP71, F3SP76

No. of subsystem stations: Max. 30 stations/ALE111

Communication protocol: TCP/IP

*1: CENTUM VP Release 5.03 or later version supports these devices.

Table List of Applicable Devices

Device type	Device name	Communication capacity (per communication)	Read	Write
Bit device	Input relay	256 words (4096 points) (*1) (*3)	Y	Y
	Output relay		Y	Y
	Internal relay		Y	Y
	Shared relay		Y	Y
	Link relay		Y	Y
	Special relay		Y	Y
	Time up relay		Y	Y
	Count-up relay		Y	Y
Word device	Decrementing timer current value	256 words (*2) (*3)	Y	Y
	Incrementing timer current value		Y	Y
	Timer set value		Y	Y
	Decrementing counter current value		Y	Y
	Incrementing timer current value		Y	Y
	Counter set value		Y	Y
	Data register		Y	Y
	Link register		Y	Y
	Shared register		Y	Y
	File register		Y	Y
	Index register		Y	Y
	Special register		Y	Y
	Cash register (*4)		N	N

Y: Applicable

N: Not applicable

*1: Communication capacity is 16 words (256 points) for FA-M3 CPU F3SP21, F3SP25, and F3SP35.

*2: Communication capacity is 64 words for FA-M3 CPU F3SP21, F3SP25, and F3SP35.

*3: Due to the limitation of FA-M3 F3LE01-5T Ethernet interface module, an attempt to write words exceeding the 249 word will cause an error.

*4: This device is for F3SP71 and F3SP76.

● **Modbus Communication**

Connected device:

- FCN: NFCP100
- FCJ: NFJT100
- GC1000 Mark II, GC8000 (*1)
- FA-M3: F3SP71-4N, F3SP76-7N
- Quantum: 140NOE77100
- Premium: TSXETY410

Connection method:

Ethernet connection via a hub. Or, with a 10BASE-T connection, a crossover cable can also be used for a peer-to-peer connection without a hub.

Applicable devices:

- By Yokogawa – STARDOM FCN and FCJ, GC1000 Mark II, GC8000, FA-M3
- By Schneider Electric – Modicon Quantum, Premium

Transmission protocol:

Conforms to OPEN Modbus/TCP SPECIFICATION Release 1.0, 29 March 1999 Andy Swales Schneider Electric protocol

No. of subsystem stations: Max. 30 stations/ALE111

Communication protocol: TCP/IP

*1: CENTUM VP Release 5.03 or later version supports this device.

Table List of Applicable Devices

Device type	Device name	Communication capacity (per communication)	Read	Write
Bit device	Coil	Read: 125 words Write: 50 words	Y (*1)	Y
	Input Relay		Y	N
Word device	Input register	Read: 125 words Write: 100 words	Y	N
	Maintenance register		Y (*1)	Y
Other device	Specific coil (*2)	1 word	Y	N
	Communication status		Y	N

- Y: Applicable N: Not applicable
- *1: This device may not be able to read some function codes.
- *2: This device is not supported by GC1000 Mark II, GC8000 and FA-M3.

● **MELSEC Communication**

Connected device:

- Q Series built-in Ethernet port CPU (10BASE-T, 100BASE-TX)
Q03UDE, Q04UDEH, Q06UDEH, Q10UDEH, Q13UDEH, Q20UDEH, Q26UDEH, 50UDEH, Q100UDEH
- iQ-R Series built-in Ethernet port CPU (10BASE-T, 100BASE-TX)
R08PCPU, R16PCPU, R32PCPU, R120PCPU
- Ethernet interface module
- A Series:
AJ71E71-S3 (10BASE-2/5), A1SJ71E71-B2-S3 (10BASE-2), A1SJ71E71-B5-S3 (10BASE-5),
AJ71E71N-B2 (10BASE-2), AJ71E71N-B5 (10BASE-5), AJ71E71N-T (10BASE-T),
AJ71E71N3-T (10BASE-T), A1SJ71E71N-B2 (10BASE-2), A1SJ71E71N-B5 (10BASE-5),
A1SJ71E71N-T (10BASE-T), A1SJ71E71N3-T (10BASE-T)
- QnA Series:
AJ71QE71 (10BASE-2/5), AJ71QE71-B5 (10BASE-5), A1SJ71QE71-B2 (10BASE-2),
A1SJ71QE71-B5 (10BASE-5), AJ71QE71N-B2 (10BASE-2) AJ71QE71N-B5 (10BASE-5),
AJ71QE71N-T (10BASE-T), AJ71QE71N3-T (10BASE-T), A1SJ71QE71N-B2 (10BASE-2),
A1SJ71QE71N-B5 (10BASE-5), A1SJ71QE71N-T (10BASE-T), A1SJ71QE71N3-T (10BASE-T)
- Q Series:
QJ71E71 (10BASE-T/5), QJ71E71-B2 (10BASE-2), QJ71E71-B5 (10BASE-5),
QJ71E71-100 (10BASE-T, 100BASE-TX)
- iQ-R Series:
RJ71EN71 (10BASE-T, 100BASE-TX, 1000BASE-T)

Connection method: Ethernet connection via a hub. The communication via MELSECNET is not accessible.

Applicable devices: Q series built-in Ethernet port CPU and iQ-R series built-in Ethernet port CPU and the A, QnA, Q series, and iQ-R series that can be used with the above Ethernet interface modules. (*1)

Transmission protocol:

A series: A-compatible 1E frame

QnA, Q series (except Ethernet port of the built-in Ethernet port CPU):

QnA-compatible 3E frame, A-compatible 1E frame (*2)

Q series (Ethernet port of the built-in Ethernet port CPU): QnA-compatible 3E frame

iQ-R series: QnA-compatible 3E frame

No. of subsystem stations: Max. 30 stations/ALE111

Communication protocol: TCP/IP

*1: For the communication using A series and QnA series Ethernet interface module, a ladder program is required for MELSEC side for Ethernet interface module parameters setting, etc. For details, please refer to the MELSEC's instruction manual(s).

*2: Both the A-compatible 1E frame and the QnA-compatible 3E frame can be used at the same time by each communication receiver.

Table List of Applicable Devices

Device type	Device name	Communication capacity (per communication)	Read	Write
Bit device	Input/output relay	For A-compatible 1E frame: 128 words (2048 points) For QnA-compatible 3E frame: 960 words (15360 points) (*2)	Y	Y
	Link input (*1)		Y	Y
	Link output (*1)		Y	Y
	Internal relay		Y	Y
	Latch relay (*1)		Y	Y
	Step relay (*1)		Y	Y
	Edge relay		Y	Y
	Annunciator		Y	Y
	Link relay		Y	Y
	Special link relay		Y	Y
	Special relay		Y	Y
	Timer (contact, coil)		Y	Y
	Integration timer (contact, coil)		Y	Y
	Counter (contact, coil)		Y	Y
Word device	Data register	For A-compatible 1E frame: 256 words For QnA-compatible 3E frame: 960 words (*2)	Y	Y
	Link register		Y	Y
	Timer (current value)		Y	Y
	Integrating timer (current value) (*1)		Y	Y
	Counter (current value)		Y	Y
	File register (*3)		Y	Y (*4)
	Special register		Y	Y
	Special link register (*1)		Y	Y
	Index register (*1)		Y	Y

Y: Applicable

N: Not applicable

*1: It is possible to communicate by using QnA-compatible 3E frame.

*2: As for QnA-compatible 3E frame, the maximum data capacity per communication changes by the combination of the MELSEC CPU and the interface modules. Please confirm MELSEC specifications for more details.

*3: As for Q Series, QnA Series CPU, and iQ-R series it is possible to communicate only with the QnA-compatible 3E frame.

*4: As for Q Series, QnA Series CPU, or iQ-R series it is not possible to write to the EEPROM file register.

● **YFGW Communication**

- Connected device: Field wireless gateway
 - YFGW410 Field wireless management station
 - YFGW710 Field wireless integrated gateway
 - Max. No. of connected device:
 - 4 units of Field wireless gateway per ALE111 (*1) (*2)
 - Max. No. of connected ALE111:
 - 4 modules (8 modules for dual-redundant configuration) per Field wireless gateway (*1) (*2)
 - No. of maximum field wireless devices to be connected: 128 units/ALE111
 - 2000 units/FCS (For FCS models AFV30□/AFV40□) (*3)
 - 1000 units/FCS (For all the FCS models except AFV30□/AFV40□) (*3)
 - Transmission protocol: Modbus/TCP
 - Communication Capacity: Max. read 125 words/communication, Max. write 123 words/communication
 - No. of subsystem stations:
 - Max. 128 stations/ALE111
(For CENTUM VP R5.02 or later with FCS's main memory 32 Mbyte and more)
 - Max. 30 stations/ALE111
(For CENTUM VP R5.02 or later with FCS's main memory 16 Mbyte, and for CENTUM VP R5.01 or earlier regardless FCS's main memory size)
 - CPU loading:
 - Within +/- 10% per 2000 field wireless devices (For FCS models AFV30□/AFV40□)
 - Within +/- 10% per 1000 field wireless devices (For all the FCS models except AFV30□/AFV40□)
 - Data acquisition cycle:
 - Within 1 second per 2000 field wireless devices (For FCS models AFV30□/AFV40□) (*4)
 - Within 1 second per 1000 field wireless devices (For all the FCS models except AFV30□/AFV40□) (*4)
 - Dual-redundant configuration:
 - Dual-redundant network configuration only (YFGW410)
 - Ethernet communication module dual-redundant configuration only (YFGW710)
- *1: In a single configuration where only one module of ALE111 exists in the subsystem network, up to four units of YFGW410 and/or YFGW710 can be connected. In case there are multiple numbers of ALE111 module exist in the subsystem network, only one unit of either YFGW410 or YFGW710 can be connected.
- *2: In a dual-redundant configuration where redundant ALE111 modules (max. 8 modules) exist, only one of either one unit of YFGW710 or redundant (2 units) YFGW410 can be connected. In case ALE111 modules are set in dual-redundant configuration, a single (one unit) YFGW410 cannot be connected.
- *3: In case one communication definition (4 word) per field wireless device.
- *4: This is the data acquisition cycle from field wireless integrated gateway. The data update period of the field wireless devices depends on the transmission cycle of each device.

Table List of Applicable Devices

Object	Attribute	Read	Write
AI (analog input)	PV (Process data)	Y	N
DI (digital input) (*1)	PV_B (Process data)	Y	N
AO (analog output) (*1)	OP (Process data)	N	Y
DO (digital output) (*1)	OP_B (Process data)	N	Y
AO (analog output) (*1)	Readback (Read back)	Y	N
DO (digital output) (*1)	Readback_B (Read back)	Y	N
UAPMO (User Application Management Object)	DIAG_STATUS (Device diagnosis information)	Y	N
—	GW_STATUS (*1) (Status of Field Wireless Management Station)	Y	N
—	BBR_STATUS (*1) (Status of Field Wireless Access Point)	Y	N
—	DEV_STATUS (*1) (Status of Wireless Field Device)	Y	N

Y: Applicable
 N: Not applicable
 *1: These devices are for YFGW410.

● **DARWIN/DAQSTATION/SMARTDAC+ Communication**

Connected device: Ethernet communication module DT300-41 (DARWIN) (STYLE S8 or later)
 (DAQSTATION and SMARTDAC+ must be equipped with Ethernet in the main unit)
 Connection method: Ethernet communication via a hub. A crossover cable can also be used for a connection without a hub.

Applicable devices:

DARWIN: DA100, DC100, DR231, DR232, DR241, DR242 (STYLE S8 or later)
 DAQSTATION: DX100, DX200
 SMARTDAC+ (*1): GX10 (*2), GX20 (*2), GP10 (*2), GP20 (*2), GM10

No. of subsystem stations: Max. 30 stations/ALE111

Communication protocol: TCP/IP

*1: For the communication with SMARTDAC+, it is possible to access the devices via DARWIN-compatible communication mode.

*2: The communication can be established with GX10/GX20/GP10/GP20 Release 2 (Version 2.01.01) or later.

Table List of Applicable Devices

Data name	Communication capacity (per communication)	Read	Write
Alarm status	DARWIN/SMARTDAC+: 60 words DAQSTATION: 30 words	Y	N
Measurement data	DARWIN/SMARTDAC+: 60 words DAQSTATION: 30 words	Y	N
Calculation data	DARWIN/SMARTDAC+: 120 words DAQSTATION: 60 words	Y (*1)	N

Y: Applicable

N: Not applicable

*1: This package supports only data import from DARWIN/DAQSTATION/SMARTDAC+. Calculation start/stop has to be handled on the DARWIN/DAQSTATION/SMARTDAC+ side.

● **PLC-5/SLC500 Communication**

Connected device: PLC-S/SLC500 CPU module (CPU module equipped with communication ports)
 Communication method: Ethernet connection via a hub. Or, with a 10BASE-T connection, a crossover cable can also be used for a peer-to-peer connection without a hub. The communication via DH+ is not accessible.

Applicable device: PLC-5/SLC500 CPU modules

PLC-5: PLC-5/20E, PLC-5/40E, PLC-5/80E
 SLC500: SLC5/05

Transmission method: CSP protocol (Not complied with CIP protocol.)

No. of subsystem stations: Max. 30 stations/ALE111

(Sum of PLC-5 and SLC500, both devices can be resided together.)

Communication protocol: TCP/IP

Table List of Applicable Devices

Device type	Device name	Communication capacity (per communication)		Read	Write
		PLC-5	SLC500		
Bit file	Output image file	12 words (192 points)	–	Y (*1)	N
	Input image file	12 words (192 points)	–	Y (*1)	N
	Status file	8 words (128 points)	8 words (128 points)	Y	N
	Bit file	600 words (600 points)	256 words (256 points)	Y	Y
Word file	Timer file	300 words (100 points)	300 words (100 points)	Y	Y
	Counter file	600 words (200 points)	600 words (200 points)	Y	Y
	Control file	600 words (200 points)	600 words (200 points)	Y	Y
	Integer file	600 words (600 points)	256 words (256 points)	Y	Y
	Floating point file	600 words (300 points)	512 words (256 points)	Y	Y

Y: Applicable

N: Not applicable

*1: Not readable by SLC500.

■ DUAL-REDUNDANCY OF COMMUNICATION

● Functional Overview

The Ethernet communication module can be made dual-redundant by setting two ALE111 modules in the adjacent (odd- and even-numbered) slots of the same node unit. (*1)

*1: DAQSTATION cannot be made dual-redundant due to the limitation in number of subsystems that can be connected simultaneously.

● Data Input Flow

Each of the two ALE111 modules communicates with the subsystem and reads the subsystem input image data into the module. An FCS accesses the control communication module to read and use these data; however, it does not access the standby communication module. When the FCS detects a control communication module error or subsystem communication failure, the FCS switches its control to the standby module from which to read data.

● Data Output Flow

A control communication module outputs data to a subsystem. The control communication module writes data to the subsystem at the specified intervals when an FCS sets the data in it.

Meanwhile, the standby communication module re-reads and retains the output image data when it accesses the subsystem at the specified interval. This equalizes the data between the control and standby communication modules.

When an error is detected, the FCS switches its control to the stand-by module through which the FCS continues to output data to the subsystem.

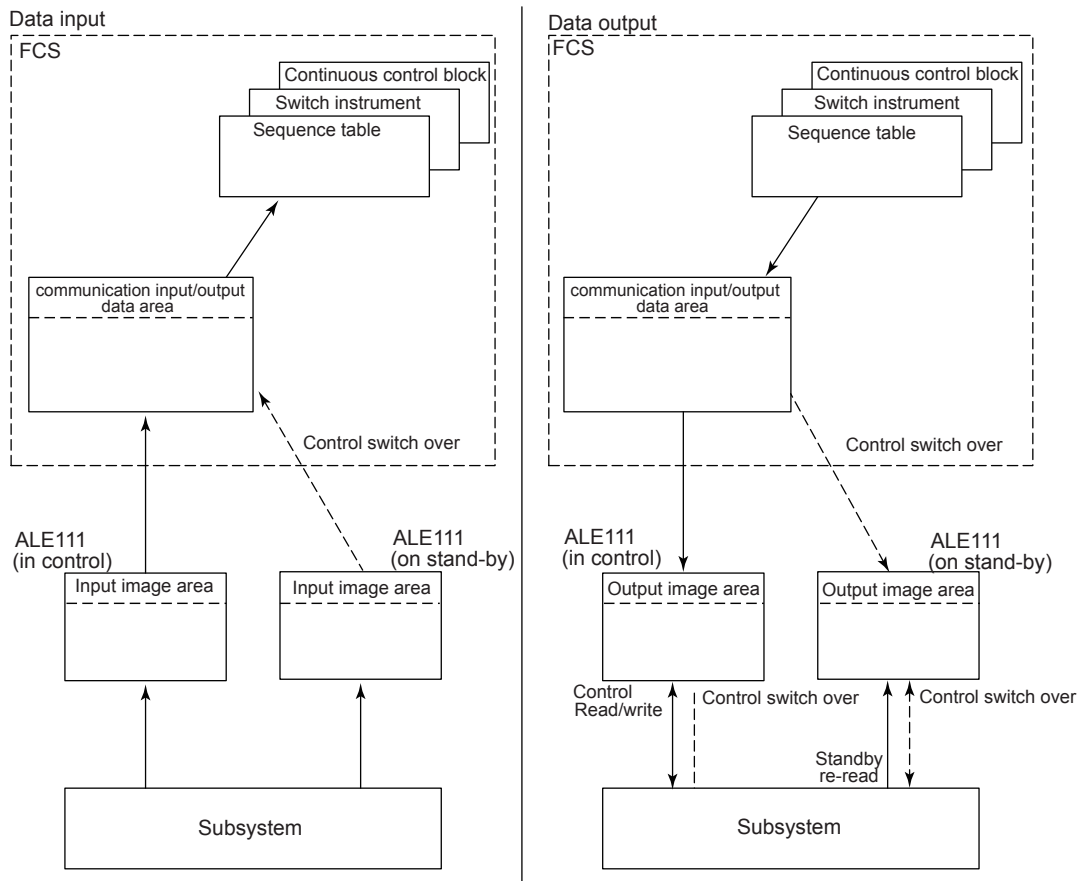

F03E.ai

Figure Data Flow in Dual-redundant Configuration

● **Dual-redundant Configuration**

There are two types in ALE111 dual-redundant configuration.

Ethernet communication module dual-redundant configuration

Insert a pair of ALE111 on an FCS to make them work in the same network domain.

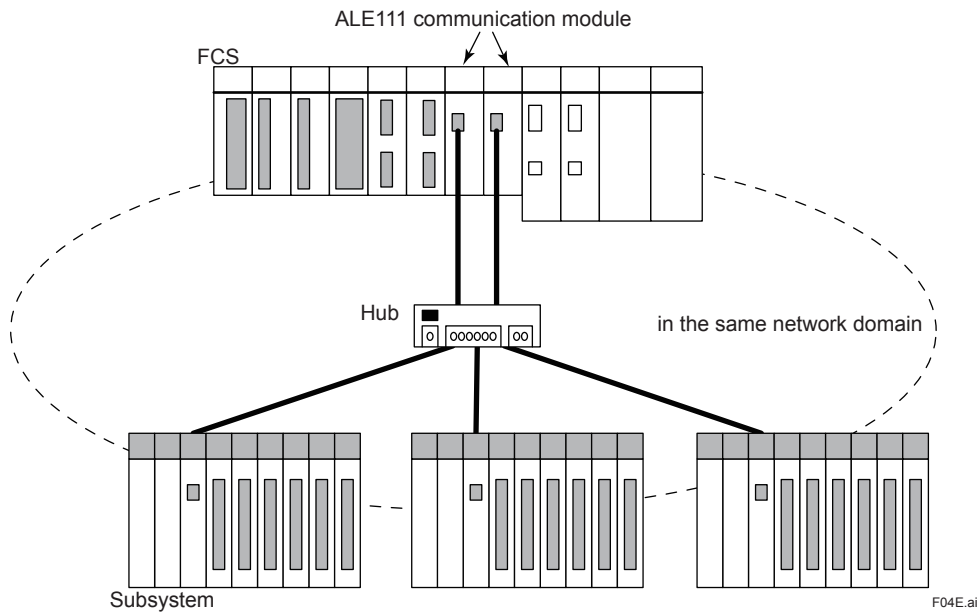

Figure Dual-redundant Configuration of the Ethernet Communication Modules (for Communication Modules Only)

Dual-redundant network configuration

Not only ALE111 modules but also the communication interface between the network and the subsystems can also be in dual-redundant configuration. (*1) By segmenting the two ALE111 network domains, the network itself can be made dual-redundant. In case that the network communication with the subsystems is done via gateways, the network domain beyond the gateway must be in the same network, and not segmented.

*1: With DARWIN, SMARTDAC+, and YFGW, the Ethernet communication module can be made dual-redundant configuration, but not the communication network itself.

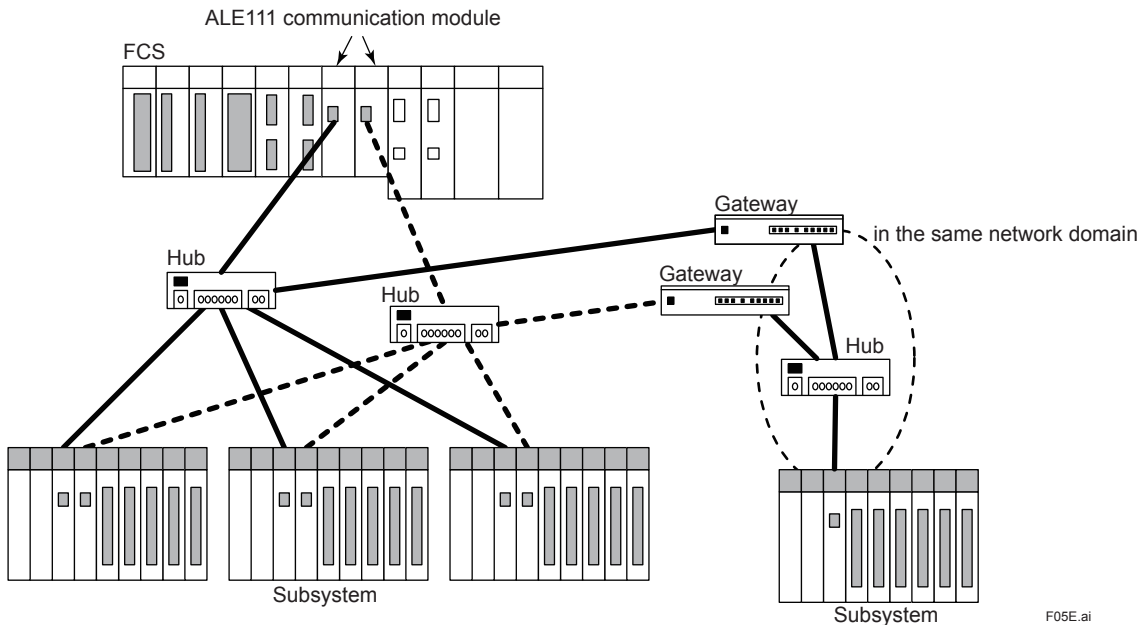
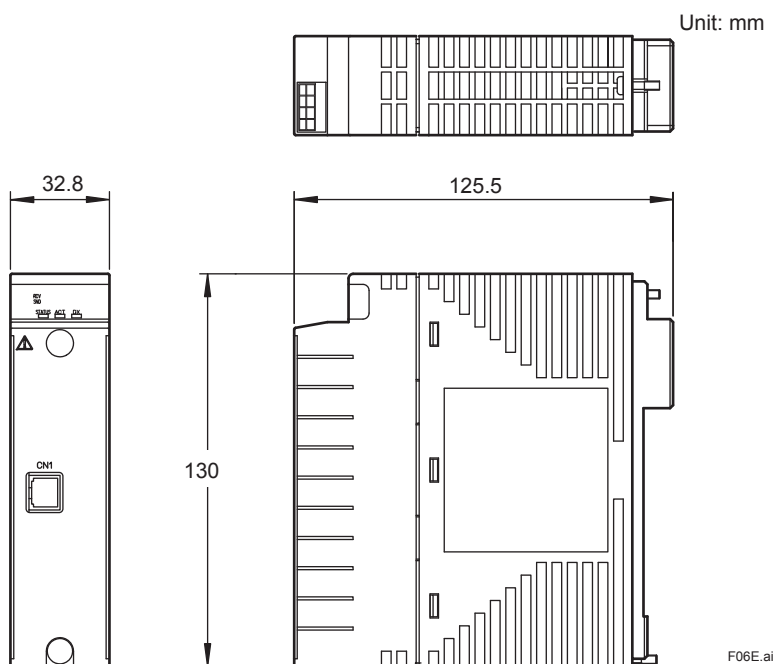

Figure Dual-redundant Configuration of the Ethernet Communication Module (Redundancy of the Network)

EXTERNAL DIMENSIONS



Nominal Tolerances :

When the reference dimension is over 0.5 mm and equal or less than 120 mm, its nominal tolerance is ± 0.8 mm, while its combination of nominal tolerance is ± 1.5 mm.

When the reference dimension is over 120 mm, its nominal tolerance is in accordance with JEM 1459.

MODEL AND SUFFIX CODES

		Description
Model	ALE111	Ethernet Communication Module (for N-IO/FIO)
Suffix Codes	-S	Standard Type
	5	With no explosion protection
	E	With explosion protection
	0	Basic Type
	1	With ISA Standard G3 option
	3	With ISA Standard G3 option and temperature (-20 to 70 °C) option

APPLICABLE STANDARDS

Refer to the GS "Integrated Production Control System CENTUM VP System Overview" (GS 33J01A10-01EN).

ORDERING INFORMATION

Specify model and suffix codes when ordering.

For selecting the right products for explosion protection, please refer to TI 33Q01J30-01E without fail.

TRADEMARK ACKNOWLEDGEMENT

The names of corporations, organizations, products and logos herein are either registered trademarks or trademarks of Yokogawa Electric Corporation and their respective holders.