

Technical Information

Integrated Production Control System
CENTUM VP
System Overview (General Overview)



TI 33K01A10-50E

[Release 5]

Blank Page

Introduction

CENTUM VP integrated production control system is applied to control and manage plant operations in various industries such as oil and gas, petrochemicals, chemicals, power, pulp and paper, pharmaceuticals, food, iron and steel, waste, and water and sewage treatment.

This document describes a general overview of the CENTUM VP system. Further details are available by the series of documents such as System Overview (HMI), System Overview (FCS), and General Specifications (GS) for individual products.

■ Relevant Manual

TI 32S01B10-01E ProSafe-RS System Overview

■ Target Readership for This Manual

This manual is mainly intended for:

Instrumentation, electric and computer engineers who are evaluating CENTUM VP for purchase or who will be in charge of installation.

■ Trademarks

CENTUM, ProSafe, Vnet/IP and VigilantPlant are registered trademarks of Yokogawa Electric Corporation.

Windows is registered trademarks of Microsoft Corporation in United States and/or other countries.

Ethernet is a registered trademark of Xerox Corporation.

PLC is a registered trademark of Rockwell Automation, inc.

“FOUNDATION” in “FOUNDATION fieldbus” is a registered trademark of Fieldbus Foundation.

Other product and company names may be registered trademarks of their respective companies (the TM or R mark is not displayed).

Blank Page

Integrated Production Control System

CENTUM VP

System Overview

TI 33K01A10-50E 1st Edition

CONTENTS

1.	CENTUM VP Overview	1-1
1.1	History of CENTUM.....	1-1
1.2	CENTUM at Work	1-2
1.3	Concept of CENTUM VP	1-3
1.4	CENTUM VP Advantages	1-4
2.	System Configuration.....	2-1
3.	Control Function (FCS).....	3-1
4.	Human Machine Interface (HIS)	4-1
5.	Integration with ProSafe-RS.....	5-1
6.	Openness and Interoperability	6-1
7.	Plant Lifecycle	7-1

Blank Page

1. CENTUM VP Overview

Yokogawa is the world's first company that introduced the distributed control system (DCS) in 1975 - the first series of CENTUM Systems. Ever since, Yokogawa kept developing and enhancing the CENTUM series systems by complying with what customers (managers, operators, engineers, and so on) requirements. As the generations of CENTUM advanced Yokogawa kept improving its product quality achieving the highest level of reliability in the market. CENTUM systems have been adopted by customers around the world to control and monitor their industrial plants.

1.1 History of CENTUM

Innovations of operation in the process industries have come a long way since the age of panel-mounted loop controllers. In early 1970s, a panel operator was assigned for operation per panel. However, by the introduction of a DCS, operators' ways of working have drastically changed. Operators can grasp the plant-wide operation by sitting in a central control room (CCR). And their work scope has largely been extended.

The CENTUM systems kept evolving to increase productivity and improve plant operations in the past 35 years, and CENTUM VP is the 8th generation of the CENTUM Series. Yokogawa has adopted the latest state-of-the-art technologies of the time to develop the systems, keeping return on the investment (ROI) and the total cost of ownership (TCO) in minds.

Yokogawa has always been offering a smooth migration path from an existing CENTUM system into the latest one. It provides customers the benefits of using the existing system as long as they wish yet allows them to adopt the latest technologies with a minimum investment. Yokogawa's CENTUM systems have been replaced with the latest ones smoothly with minimum shutdown time.

Yokogawa continually endeavors to meet customers' needs by providing highly reliable control systems based on the leading edge technology.

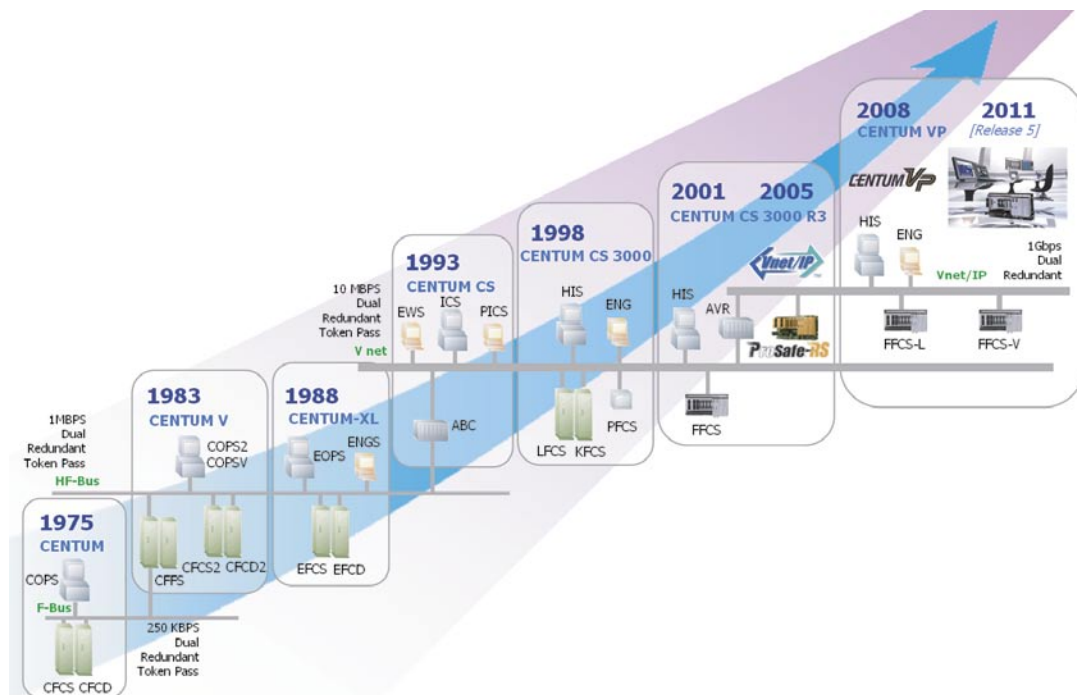

F010101.ai

Figure History of CENTUM

1.2 CENTUM at Work

Yokogawa has sold over 22,000 CENTUM projects in all kinds of industrial plants worldwide such as oil and gas, petrochemicals, chemicals, power, pulp and paper, pharmaceuticals, food, iron and steel, waste, and water and sewage treatment. The majority of the customers are from oil and gas, and petrochemical industries. It means that once the CENTUM system is delivered and start its operation, it has to be in operation non-stop.

In the past 35 years of experience, Yokogawa is reputed with the high reliability of the CENTUM system winning customer satisfactions. Yokogawa is engaged in the global purchase agreements with world major customers as their sole instrumentation supplier. Yokogawa needs only one project to convince customers of our capability and win trust. Once Yokogawa system is delivered, customers stay with Yokogawa.

As of March, 2011

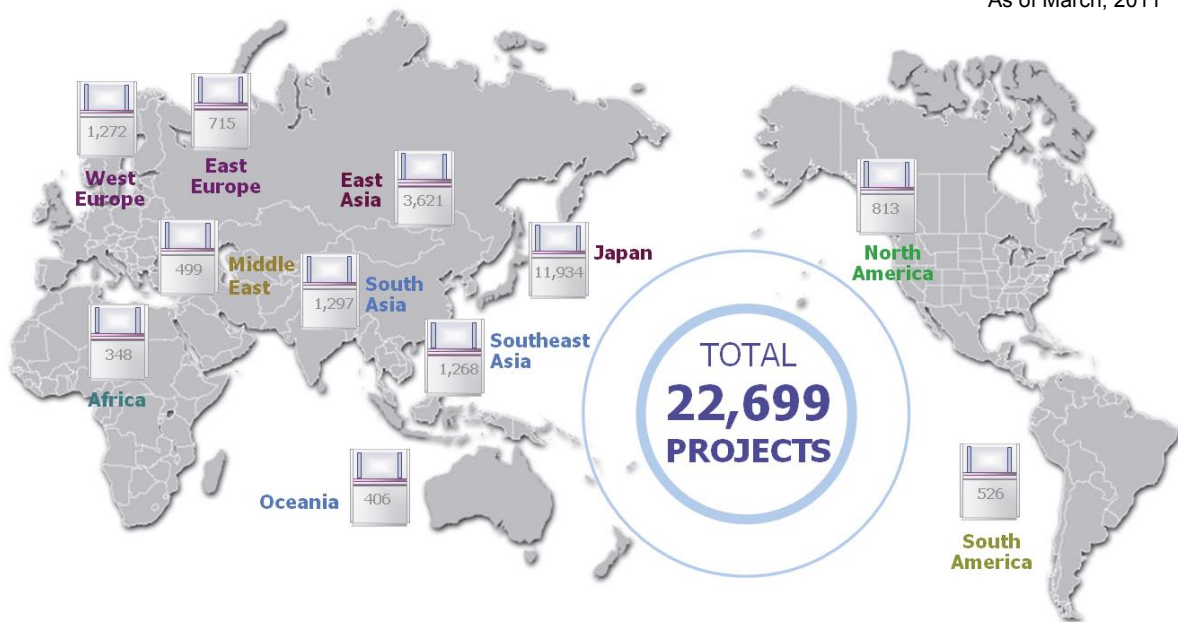

F010201.ai

Figure CENTUM at work

1.3 Concept of CENTUM VP

CENTUM VP is the core platform for Yokogawa VigilantPlant Solutions. It is designed to empower all members in the production value chain to **See Clearly, Know in Advance, and Act with Agility**.

CENTUM VP ushers in an operating environment that keeps everyone fully aware, well informed, and ready to face the next challenge.

■ See Clearly (Information visibility)

CENTUM VP makes critical plant information visible in a meaningful and actionable manner.

CENTUM VP captures plant-wide data without delay and delivers the right information to the right people at the right time. Reducing blind spots while preventing information overload, CENTUM VP keeps people's attention firmly focused on operational targets and business goals.

■ Know in Advance (Performance foresight)

CENTUM VP delivers the knowledge necessary to anticipate changes and to make fast, informed decisions.

CENTUM VP enables quick synthesis of analytic insights from the historical, real-time, and future-predictive perspectives. Allowing people to make fast intelligent decisions every day, CENTUM VP helps your business avoid costly surprises.

■ Act with Agility (Operational agility)

CENTUM VP helps to implement decisions throughout the value chain without delay.

CENTUM VP speeds up task coordination and navigation, enhancing the flexibility of production and adaptability of business. Constantly systemizing and automating operational best practices, CENTUM VP prevents delays and preempts bottlenecks.



F010301.ai

1.4 CENTUM VP Advantages

■ For Operations

- **Safe and unified plant operations**

Universal interface for control, safety, and asset intelligence.
Embedded mechanisms to prevent information overload

- **Non-stop improvement**

Continuous systemization of operational best practices and context specific operational advisories.

■ For Production Management

- **Faster Plan, Do, Check, and Act cycle for agile adaptation**

MES and enterprise system integration is enabled by using S95 and B2MML standards

- **Secure and standard-based information integration**

Built-in control network security certified by experts

■ For Maintenance

- **Continuous evolution without compromising asset availability**

Evergreen evolution with online upgrades and modifications. It is the most reliable platform with no single point of failure

- **Long-term investment protection**

Step-by-step phased migration paths incorporated before any new release. We have over 35 years of backward compatibility.

■ For Project

- **Faster project execution with fewer integration risks**

Single-source integrated solutions for control system (DCS), safety instrumented system (SIS), embedded plant information management system (PIMS), intelligent RTU & SCADA, and turbine controller.

2. System Configuration

CENTUM VP has a simple & common architecture consisting of human machine interfaces called human interface station (HIS), field control stations (FCS), and a control network. These three basic components support facilities from the tiny to very large and complex with up to 1,000,000 tags.

■ The Design Concept of CENTUM VP System Configuration

CENTUM VP is designed based on the concept to keep the plant operation availability high. Customers expect Yokogawa products to perform its functions without failure so that the plant operations shall not stop. Yokogawa developed our own FCSs so that we can meet up with the customers' expectations. Quite a number of FCSs are still in operation even after 20 or more years passed since those are originally installed. It is owing to the high quality of the products themselves that has been supported by the total serviceability such as skilled manufacturing, quality control, after sales service and appropriate training.

● Self-independent Controller

CENTUM VP's FCSs are designed to work without HIS. The fundamental controls can be done only by the FCSs, and all the process data, control logic, and procedures are contained in the controllers. HIS works only as a monitor screen under the normal condition. In Yokogawa's system configuration, FCSs are acting like servers and HISs as clients. The hardware availability of FCS (=server) is 99.99999% which comes from the basic policy in product designs. Our FCSs are designed; (a) not causing failures easily (fault-avoidance), (b) to continue controlling the plant even it fails (fault-tolerant), and (c) to recover from failures as quickly as possible (maintainability). It is the crystallization of Yokogawa's leading edge technology.

● Why CENTUM VP does not have Client-Server Concept?

In a typical server-client configuration, when the server fails, all the client HMIs come to stop. It means that all the controls and the data of the plant are lost until the server is recovered. This is certainly not an acceptable situation for plant operations in reality. In order to prevent server down as much as possible, an expensive server machine is needed or to have a redundant configuration.

CENTUM VP's Field Control Stations (FCSs) are far superior to the PC servers on account of availability, even those with redundant configuration. Each FCS runs independently that hedges the risk of causing serious damage to the plant by a single failure.

PC servers become obsolete in a few years of cycles, but FCSs with appropriate maintenance runs for many years. The robustness of FCS saves the cost of repairs and damages to the plants as the plant does not fail. In the viewpoint of total cost of ownership (TCO), Yokogawa's FCS is more economical.

■ CENTUM VP Components

In this section, a term “PC” means an Intel x86-based computer which has inherited IBM PC/AT compatible machine, and it runs on the Microsoft Windows OS. The PC means not only a personal computer but also a workstation and a server.

● Human Interface Station (HIS)

CENTUM VP uses a PC for its human machine interface. It is called HIS when the software packages for control and monitoring functions are installed there. The desk top type and a console type with assembled displays are selectable.

● Engineering Station (ENG)

ENG is a PC used for system configuration and maintenance. A single PC can be used for both HIS and ENG functions. The engineering functions can be realized by applying the engineering-related software.

● Field Control Station (FCS)

FCS is a high reliability controller designed and manufactured by Yokogawa. It performs control computation functions for each function block and input/output functions for process and software inputs/outputs. FCS hardware can be selectable from a cabinet type or a rack-mountable type. It consists of a field control unit (FCU) and node units to mount input/output modules. It enables to configure a scalable system by connecting several node units in a FCS in accordance with the I/O points.

● Generic Subsystem Gateway (GSGW)

GSGW is a station for operation and monitoring subsystems. By using a PC as a platform, it establishes subsystem communications via OPC DA(*1) interface defined by the OPC Foundation. Subsystem data is assigned to the GSGW's function blocks to be controlled and monitored via HIS in the same manners as other control stations.

*1: Open Product Connectivity, Data Access

● System Integration OPC Station (SIOS)

SIOS is a station to integrate CENTUM VP and the third-party process control systems (PCSs). It enables CENTUM VP to exchange data with and receives alarms and events from the third-party PCS via OPC interface.

● Unified Gateway Station (UGS)

UGS is a station exclusively used for Vnet/IP to integrate CENTUM VP and subsystem controllers such as STARDOM controllers (FCN/FCJ) and other third-party programmable logic controllers (PLCs). Its standard function allows CENTUM VP to communicate with subsystem controllers via various communication protocols such as Modbus, EtherNet/IP or OPC DA. UGS enables CENTUM VP to control and monitor those subsystems in the same way as CENTUM VP FCS.

● Advanced Process Control Station (APCS)

APCS performs advanced control and computation functions for improving plant operation efficiencies.

● Communication Gateway Unit (CGW)

CGW connects V net system and a supervisory computer via Ethernet.

- **Bus Converter (BCV)**

BCV relays CENTUM VP communications with other CENTUM VP and older CENTUM systems such as CENTUM CS 3000, CENTUM CS 1000, CENTUM CS, CENTUM-XL, CENTUM V, and μ XL.

- **V net Router (AVR)**

AVR connects and transmits control communications between the Vnet/IP and V net domains. The control data can be sent and received in both ways between the Vnet/IP and V net domains. It enables control and monitoring of the control stations among other domains.

- **Layer 2 Switch (L2SW)**

L2SW relays communications among devices connected to the Vnet/IP network. The Vnet/IP domain refers to the Vnet/IP system area connected by L2SW. Use L2SW with 1 Gbps communication speed in the Vnet/IP domain.

- **Layer 3 Switch (L3SW)**

L3SW relays communications among Vnet/IP domains. Use L3SW with 1 Gbps communication speed.

- **Control Network (Vnet/IP, V net)**

“V net” is a CENTUM VP’s conventional control bus with high reliability, responsibility, and redundancy. “Vnet/IP” is an IEEE802.3 Ethernet compliant, 1Gbps redundant network. The control network links stations such as HIS, FCS and BCV. It incorporates Yokogawa’s technology to achieve deterministic, reliable, and secure communications.

- **Digital Fieldnetworks**

CENTUM VP supports FOUNDATION fieldbus, HART, PROFIBUS-DP, DeviceNet, Modbus, Modbus/TCP, Ethernet/IP, and ISA100.11a field wireless network.

- **Network-based Control System (STARDOM)**

Yokogawa’s intelligent-hybrid remote telecommunication controllers are ideal for the oil and gas upstream market. They can be seamlessly integrated, via the UGS, to CENTUM VP.

- Autonomous Controller (FCN/FCJ)
These controllers utilize the global Standard IEC 61131-3 as the engineering tool.
- Versatile Data Server Software (ASTMAC VDS)
VDS is a SCADA software which uses Web browser (Internet Explorer) for HMI display.

- **Safety Instrumented System (ProSafe-RS)**

This is Yokogawa’s TÜV SIL3 certified premier safety instrumented system. It incorporates Yokogawa’s own Pair and Spare and Vnet/IP technologies and offers unprecedented synergy with CENTUM VP.

- **Safety Control Station (SCS)**

SCS is a Yokogawa manufactured safety controller that executes logics for systems including interlock, emergency shutdown and fire and gas protection.

- **Safety Engineering Station (SENG)**

An off-the-shelf PC that performs SCS generation and maintenance management.

Overall System Configuration

The below drawing shows an overall system configuration of the CENTUM VP integrating previous CENTUM system, the ProSafe-RS safety instrumented system, and other subsystems.

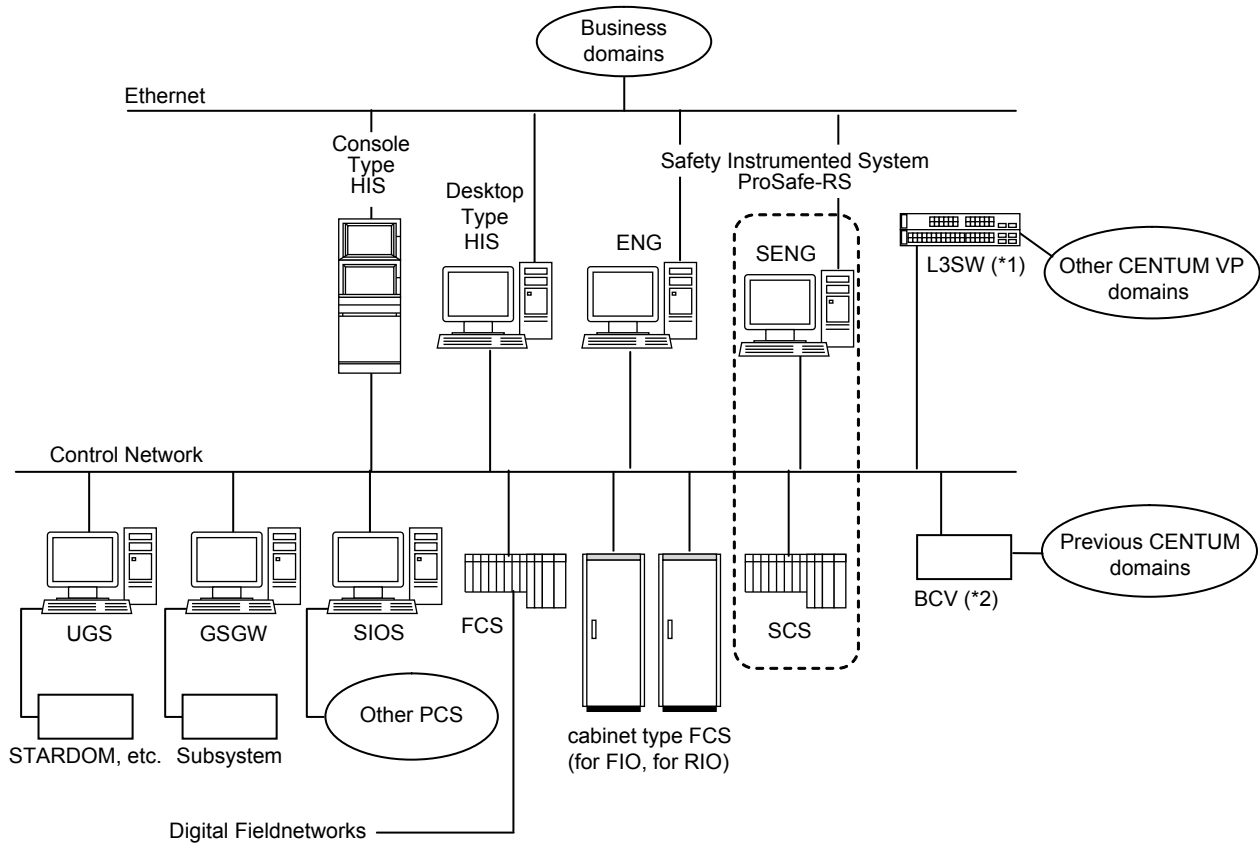

F020001.ai

- *1: When the control networks are both Vnet/IP, they are connected by L3SW. If both are V net, BCV is used. AVR is adopted between V net and Vnet/IP networks.
- *2: There are some kinds of BCV. It connects between V net and Yokogawa conventional control network - such as V net, VL net, HF-bus, and RL-bus.

■ Basic System Configuration

The system configuration below shows representative components in a basic CENTUM VP system.

System Specifications

- Number of tags that can be monitored: 100,000 tags
- Number of stations that can be connected: 256 stations

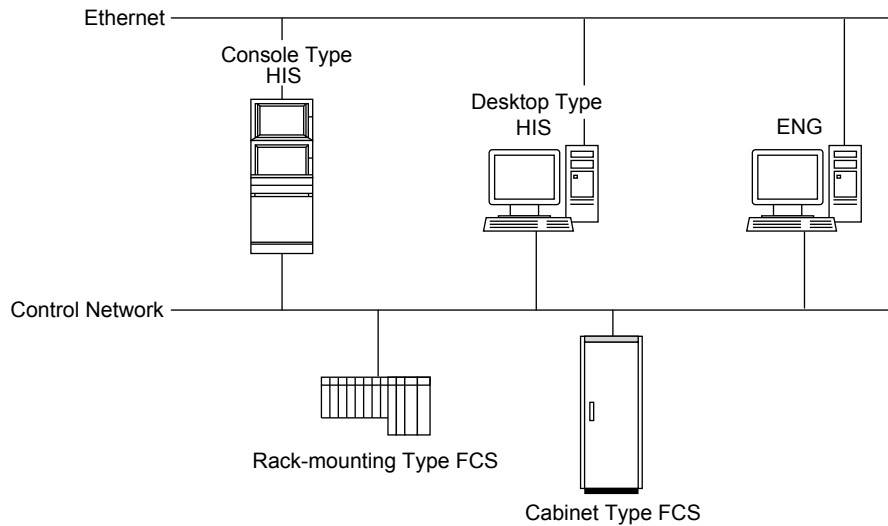

F020002.ai

■ Very Large System Configuration

An example of a very large system configuration is shown below. CENTUM VP can expand the system specifications for the very large system.

If the system expansion is required, please contact to Yokogawa's sales representative.

- Number of tags that can be monitored: 1000000 tags (When using LHS4000 Million Tag Handling Package. See GS 33K05K10-50E.)
- Number of stations that can be connected: 1024 stations

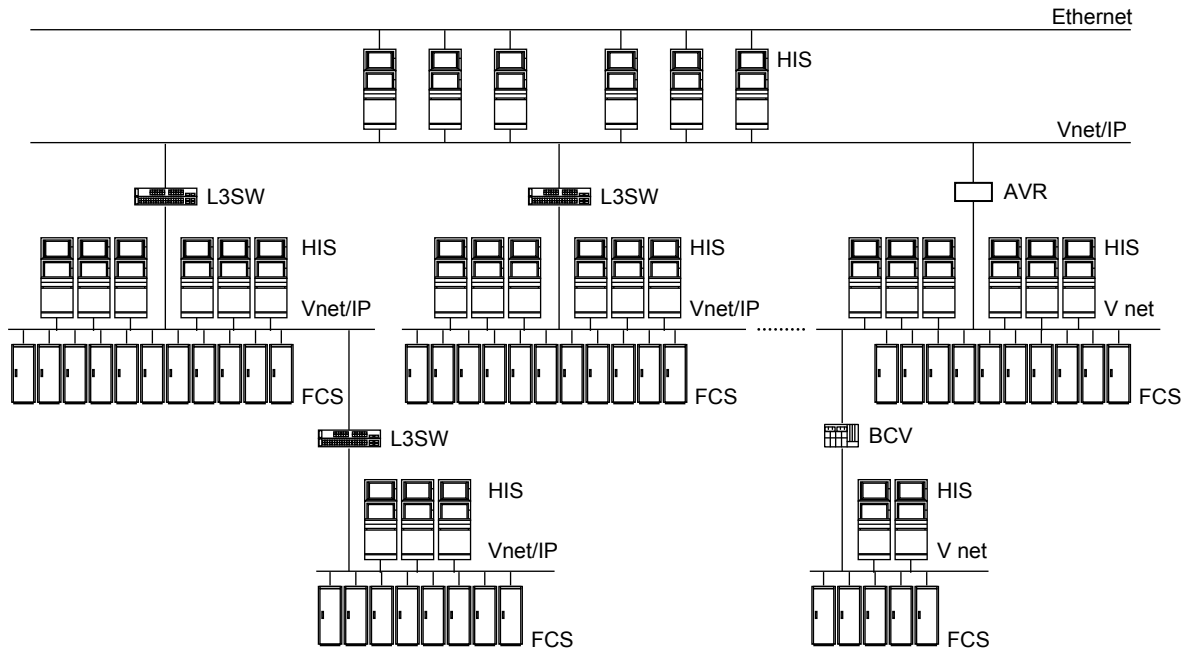

F020003.ai

■ Small System Configuration (CENTUM VP Entry Class)

The system configuration below shows a small scale system called CENTUM VP Entry Class. Other than the number of tags, CENTUM VP Entry Class has all the functionalities available with the CENTUM VP. When the customer plans for expansion of the plant, it can easily and economically be migrated into large scale systems.

System Specifications

- Number of tags that can be monitored: 8,000 tags
- Number of stations that can be connected: 256 stations

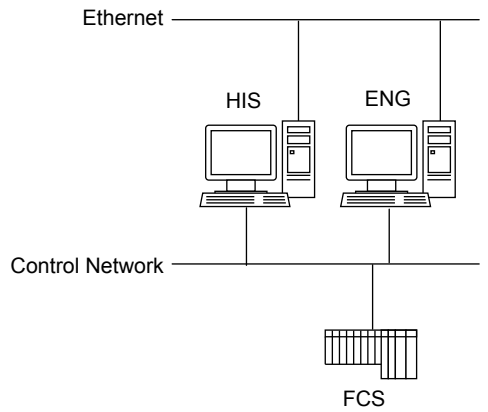

F020004.ai

■ Solution Product

Yokogawa provides system products for solutions which collaborate with CENTUM VP. The following solution products are able to integrate with CENTUM VP.

● OPC Interface Package (Exaopc)

Exaopc provides an OPC (Open Product Connectivity) interface bridge between the control room and the outside world. Exaopc is an OPC server running on a Microsoft Windows platform which can be connected to a variety of PCSs (Process Control Systems) providing OPC clients with process data and alarm events.

● Plant Information Management System (Exaquantum)

Exaquantum is a Plant Information Management System (PIMS) product that provides business benefits to users in the Hydrocarbons, Chemicals, Power & Utilities, Pulp & Paper and many other industries. The main function of Exaquantum is the acquisition of data from all facets of a business and the subsequent transformation of that data into easily usable, highvalue, widely-distributed information. The data then becomes an integral part of the set of tools used by the business in vital decision-making processes.

Exaquantum is the business intelligent gateway between the operational Process Control System (PCS) and the business Enterprise Resource Planning (ERP) system. It uses the latest, proven, Microsoft based open technology sets, designed to have low administration costs, and be robust to future IT trends.

● Operation Efficiency Improvement Package (Exapilot)

Exapilot is an operating efficiency improvement support package aimed at automating the tasks manually performed by operators such as unsteady state operations, steady state operations, or abnormal situation operations in a plant.

Exapilot makes it easy to create semi-automatic sequences that incorporate the know-how of skilled operators, and thus greatly reduce manual operation.

● Event Analysis Package (Exaplog)

The Exaplog Event Analysis Package is designed to provide managers, engineers and supervising operators with tools to analyze the historical plant operation record file of a DCS, so that the production process can be improved. It can generate trend graphs for quantitative analysis, as well as pie charts and tables for analyzing distributions and classifying events. It can help you eliminate unnecessary alarms, improve inefficient operation sequences, and thus improve production processes.

● Plant Resource Manager (PRM)

Plant Resource Manager (PRM) is an asset management software tool for the digital network era. The PRM software manages field devices and maintenance work efficiently, and help reduce total cost of ownership (TCO) in an industrial plant.

These packages support intelligent devices such as FOUNDATION fieldbus, HART, PROFIBUS, and field wireless (conforms to ISA100.11a) devices as well as conventional analog devices.

3. Control Function (FCS)

All field control stations (FCSs) in the CENTUM series, including software and hardware, have been developed by Yokogawa. We know every single bit of software and hardware to maintain a 99.99999% availability service record.

■ The state-of-the-art Field Control Station (FCS)

For over 35 years, Yokogawa has been delivering stable, high quality CENTUM systems. The CENTUM VP controller features outstanding processing performance and a large application storage capacity, yet inherits the same quality and stability that are the hallmark of the CENTUM series. It has been optimized to take full advantage of advances in field digital technology that will help plants operate with increased efficiency and stability.

■ Compact Design

Compact components reduce the overall “footprint” of the control system, allowing savings from smaller equipment rooms. For convenience, both the FCS and its I/O node units can be placed in remote classified locations (IEC Zone2/Class I Div. 2), providing installation savings.

■ Online Maintenance

FCS applications can be modified without interrupting process control from the engineering station.

■ Function Blocks

The CENTUM VP provides function blocks for monitoring, control, manipulations, calculations, logic functions, and sequence control. Not only regulatory control but also advanced control, complicated sequence control, and batch control are all executed in a redundant, secure, and reliable controller environment. Plant systems can be flexibly designed, ranging from small- to large-scale, through the combination of these control blocks.

■ Unit Supervision

The multiple devices of a process facility which would previously have been handled individually can now be defined, operated, and monitored as a single unit, simplifying operation. Unit supervision can be applied to batch processes and continuous control processes that require complex management, expediting overall plant operation.

■ Guarantees the Highest Reliability

CENTUM VP contributes to the long-term stability of plant operations and reduces total cost of ownership.

● Designed for High Availability

Yokogawa's CENTUM series achieves high availability thanks to a dual-redundant design, online maintenance capability, and other advanced features. The FCS processor module, power supply, I/O modules, and I/O networks are all dual-redundant. Active and stand-by processor modules work in synchronization: even if a failure occurs, control switches over seamlessly to the stand-by processor module and the FCS continues running. Failed modules can be replaced online, ensuring that not even a hardware failure will interfere with the process control.

CENTUM : the DCS solution with an incredibly high 99.99999% availability!

● Designed for Stable Process Control and Increased Plant Productivity

The CENTUM series employs a pair & spare architecture that improves the stability of process control. Each processor module has redundant CPUs that execute the same computations simultaneously. Their outputs are constantly compared and a bump-less switchover to the stand-by processor module is initiated if any anomalies caused by electronic noise or other phenomena are detected. This minimizes the likelihood that errors will have any impact on process control.

All of these technologies help to make CENTUM VP the most reliable solution for enhanced safety in plant operations.

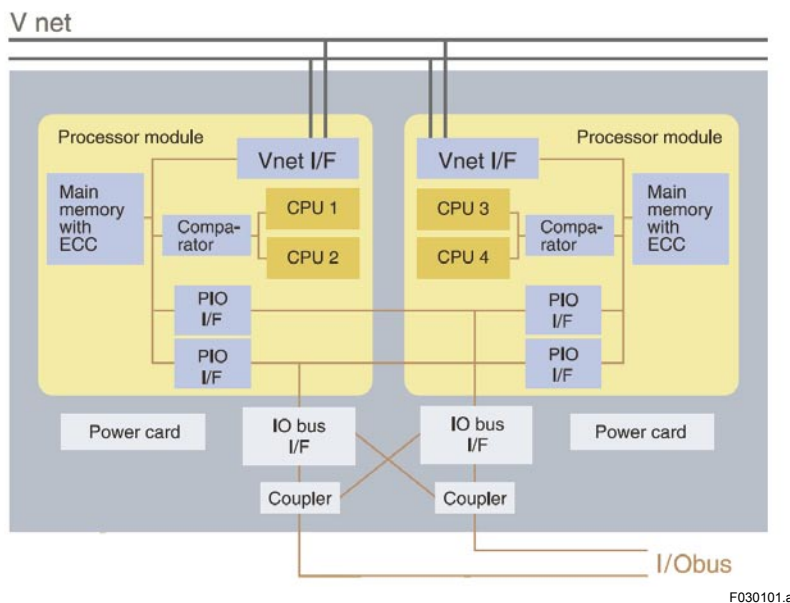

Figure Duplexed (Dual-redundant) Technology

■ Open Structure and High Reliability

Yokogawa is committed to reducing costs for our customers by enabling the use of commercial off-the-shelf technology where appropriate. Third-party cables and other network communication devices can be used with Yokogawa's Ethernet based Vnet/IP. Plant reliability is in no way compromised as the communication response is guaranteed (deterministic as opposed to probabilistic) thanks to Yokogawa's renowned reliability, dedicated protocol, and redundant configuration.

■ Subsystem Integration and Digital Fieldnetworks Support

To meet the growing need for communication with manufacturing equipment including variable speed drives, PLCs, and "smart" motor protection relays for operation and monitoring, as well as with analyzers, weighing machines, smart instruments, and other instruments used for product inspection, CENTUM VP supports a wide variety of communication interfaces and digital fieldnetworks such as FOUNDATION fieldbus, PROFIBUS-DP, Modbus RTU, Modbus TCP/IP, and Device-Net.

4. Human Machine Interface (HIS)

CENTUM VP has a new HMI (human machine interface) that makes information access quicker and more intuitive.

■ True Integration of Safety Excellence, Asset Excellence, and Production Excellence

CENTUM VP achieves the operational excellence that is the focus of Yokogawa's Safety Excellence, Asset Excellence, and Production Excellence initiatives. It offers integrated viewing and data handling functions. For example, alarms from the ProSafe-RS Safety Instrumented System and Plant Resource Manager, Yokogawa's Asset Management product, can be seen and handled seamlessly in the HIS. All plant process data, device data, and others documents are handled by CENTUM VP.

■ No Single Point of Failure

The HIS runs on Windows and offers customers the convenience of using commercial-off-the-shelf hardware. Although the reliability of a PC is relatively low, it does not affect the total reliability of the process operator function. Within CENTUM VP the HIS is not server-client dependent. Therefore multiple HISs can support each other and there is no single point of failure. The CENTUM VP supports multiple operator console configurations: desktop, open-bay console, hardened enclosed-bay console, and custom consoles.

■ Various Display Types

CENTUM VP supports both wide (16:10) and standard (4:3) size monitors. Multiple operation windows can be displayed on a single monitor. And, multiple monitors can be configured to display operation windows. With a click of a mouse, those operation windows can be moved from one to another monitor.

Note: As for console type HIS, it has one or two monitors, and screen size is fixed.

■ EEMUA Guidelines for Alarm System Design

Based on the latest edition of the EEMUA* #191 guidelines, Yokogawa has developed a Consolidated Alarm Management Software for the process operator in the HIS.

*1: Engineering Equipment & Materials Users' Association

5. Integration with ProSafe-RS

ProSafe-RS is primarily intended to be used for the following safety applications. The use of ProSafe-RS conforming to the standards for each application is also certified by TÜV.

- ESD (Emergency Shutdown System) / PSD (Process Shutdown System)
- F&G (Fire and Gas detection System: EN 54, NFPA 72)
- BMS (Burner Management System: EN 298, NFPA 85, EN 50156)

ProSafe-RS realizes the integrated safety solution with production control system (CENTUM VP) and achieves both safety and high availability.

■ Integrated Operation Environment

A guideline for functional safety defined by IEC 61508 standard calls for separation of control and safety system functions. However, operators often desire to use the same operation environments for both control and monitoring of the plant and the safety instrumented system in the actual applications. ProSafe-RS adopted the same architecture as the CENTUM VP and realizes the integrated operational environment by connecting CENTUM VP directly.

■ Achieving both Safety and High Availability

ProSafe-RS ensures shutting down of the plants safely as well as reducing the probability of stopping plant operation due to internal failures (low false trip rate or high availability).

■ Conforms to International Standard

ProSafe-RS conforms to the safety integrity level 3 (SIL3) defined by IEC 61508 and certified by TÜV Rheinland a German certification organization.

■ Plant Safety Improvement

IEC 61508 defines a quantitative target of risk reduction in the context of industrial safety, sets guidelines for achieving the goals by specific means, and stipulates to manage safety related systems based on safety lifecycles. This safety concept is based on the idea that safety should be regarded as "... freedom from unacceptable risk." The concept of "protection layers," in which independent safety measures are in layer structure from outside (local area) to the subject "plant (factory)," is required as a safety measure to materialize this allowable safety. It is required to introduce the concept of "protection layers" to achieve allowable safety, considering emergency measures not only in plant but also in cooperation with local society. ProSafe-RS provides "prevention layer" and "mitigation layer" in "protection layers."

6. Openness and Interoperability

The technological innovation enabled CENTUM VP to achieve fast, open, reliable, and real-time communication. CENTUM VP maintains the true interoperability.

■ Global Host Interoperability Support Test (HIST) Network

In the arena of FOUNDATION fieldbus, manufacturers are bringing new devices to market all the time, in addition to upgrading older instrumentation. Therefore, interoperability has always been a key issue with Yokogawa. To facilitate project management on a global basis, Yokogawa has formed a global HIST network. Test sites in Japan, the Netherlands, Houston (USA), and Singapore make sure the interoperability between Yokogawa systems and non-Yokogawa devices is acceptable. All test results are reported to Japan. This information is disclosed at <http://www.yokogawa.com/fbs/Interoperability/fbs-hist-en.htm>

■ 1 Gbit, World's Fastest Open Control Network

The real openness of a control network does not just come from using TCP/IP technology. Yokogawa's Vnet/IP provides open, reliable, and real-time broadband communications. Both CENTUM and non-CENTUM components can be connected to the network. The Yokogawa system guarantees data updates every second in the HIS, even with a large-scale project. Vnet/IP offers five millisecond time synchronization among all stations on Vnet/IP. A third-party organization has certified the security robustness of Vnet/IP and communications to the CENTUM VP FCS.

■ True Interoperability

Interoperability of Yokogawa CENTUM systems with the "outside world" begins with OPC. CENTUM VP utilizes an OPC server that meets the demands of information flow, advanced control, and alarm/event management. Our customers enjoy solid performance and wide flexibility of our OPC server for their integration projects. Yokogawa maintains interoperability with all intelligent instrumentation and deployed fieldbuses.

7. Plant Lifecycle

CENTUM VP brings cost down over the lifecycle of a plant. Maintenance is less frequent, software upgrade is easy, expansion is smooth, and even revamp is speedy.

■ Precise Project Cost Estimation

In CENTUM VP, the FCS application load can be quickly calculated in the design stage and easily monitored when on-line. During engineering design, the precise number of FCSs required is known. As the project progresses, with engineering changes, cost changes are minimized due to the simple licensing structure incorporated into CENTUM VP. This covers both the addition of stations and tags. To provide the most economical system, CENTUM VP has only two tag license boundaries: the 8,000 tags for entry level and small system architectures, and the 100,000 tags for medium to large scale plant systems. When linking multiple plants together, then we have a one-time 1,000,000 tags.

■ Virtual Test Function

A virtual FCS and HIS environment is available where both the control and operator functions of the CENTUM database can be tested without FCS hardware. Application testing and engineering time are dramatically reduced, accelerating project progress and reducing engineering cost. For system expansion and modification, applications can be tested and verified without any impact on the actual plant operation. Where ProSafe-RS is also a part of the system, then virtual testing is also available together with CENTUM VP. Our virtual test function is also a key component in building an operator training system (OTS).

■ Software Upgrading

As part of lifecycle cost management, Yokogawa has paid particular attention to upgrading all CENTUM systems. It is simple, quick, and direct. All CENTUM VP stations that are PC-based can be upgraded with one mouse click. For the FCS, if you are not using any new functions, then upgrading is not needed. Where the latest functions are desired, it takes just one mouse click to execute an FCS upgrade.

■ Multiple Project Connection

Customers are demanding different sites to be linked together so that bi-directional operation can be made more efficient. Yokogawa provides a multiple system connection function to connect several CENTUM VP sites together and link older CENTUM sites.

■ Migration

Yokogawa provides various tools and engineering methodologies for migration to CENTUM VP. Depending on the project type, you can retain field cables, I/O modules, controllers, and the control network in order to minimize your investment. A step-by-step migration starting with the HMI is easy to carry out. Software conversion tools are available for legacy Yokogawa and third-party DCSs.

Blank Page

Revision Information

- Title : Integrated Production Control System CENTUM VP System Overview (General Overview)
- Manual No. : TI 33K01A10-50E

Aug. 2011/1st Edition
Newly published

Written by Yokogawa Electric Corporation

Published by Yokogawa Electric Corporation
2-9-32 Nakacho, Musashino-shi, Tokyo 180-8750, JAPAN

Printed by KOHOKU PUBLISHING & PRINTING INC.
