

# General Specifications

## Model EJA438W and EJA438N Diaphragm Sealed Gauge Pressure Transmitters

DP *harp*

GS 01C22J03-00E

[Style: S2]

Diaphragm seal is used to prevent process medium from entering directly into the pressure-sensing assembly of the pressure transmitter. It is connected to the transmitter using capillary filled with fill fluid.

Models EJA438W and EJA438N Diaphragm Sealed Gauge Pressure Transmitters can be used to measure liquid, gas or steam pressure. They output a 4 to 20 mA DC signal corresponding to the measured pressure.

The models EJA438W and EJA438N feature remote setup and monitoring through communications with the model BT200/100 BRAIN TERMINAL, CENTUM CS/XL system etc.

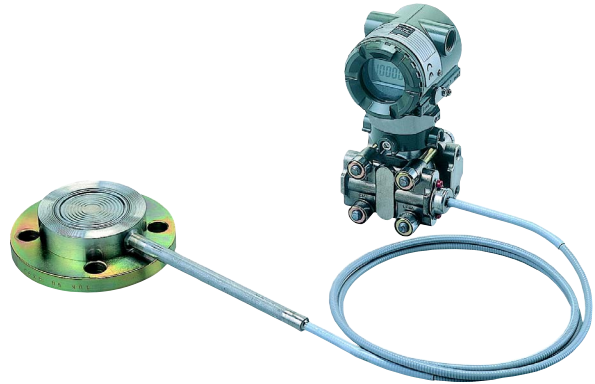

### STANDARD SPECIFICATIONS

Refer to GS 01C22T02-00E for Fieldbus communication type marked with “◇.”

#### Measurement Ranges :

Capsule	Measurement Span	Measurement Range
A *1	0.06 to 3 MPa {0.6 to 30 kgf/cm <sup>2</sup> }	-0.1 to 3 MPa {-1 to 30 kgf/cm <sup>2</sup> }
B	EJA438W *1	0.46 to 14 MPa {4.6 to 140 kgf/cm <sup>2</sup> }
	EJA438N *1	0.46 to 7 MPa {4.6 to 70 kgf/cm <sup>2</sup> }

T01E.EPS

\*1: Measurement range is within the flange rating.

#### Output Signal “◇”:

4 to 20 mA DC, 2-wire system with digital communication

#### Failure Alarm:

Output status at CPU failure and hardware error;  
Up-scale: 110%, 21.6 mA DC or more(standard)  
Down-scale: -5%, 3.2 mA DC or less  
-2.5%, 3.6 mA DC or less (Optional code /F1)  
Note: Applicable for Output signal code D and E

#### Supply Voltage “◇”:

10.5 to 42 V DC for general use and flameproof type  
10.5 to 32 V DC for lightning protector (Optional code /A)  
10.5 to 30 V DC for intrinsically safe, Type n, nonincendive, or non-sparking type  
10.5 to 28 V DC for TIIS intrinsically safe type

#### Conditions of Communication Line “◇”:

Power supply voltage;  
16.4 to 42 V DC  
Load resistance; See Figure 1.  
Note: In case of an intrinsically safe transmitter, external load resistance includes safety barrier resistance.  
Communication distance;  
2 km, when CEV polyethylene-insulated PVC-sheathed control cables are used.  
Note: Communication distance varies depends on kind of cable.

Load capacitance; 0.22 μF or less.  
Load inductance; 3.3 mH or less.  
Spacing from power line; 15 cm or more.  
Input impedance of receiver connected receiving resistance;  
10 kΩ or more at 2.4 kHz  
(See Optional Specifications for Intrinsically safe type)

#### Accuracy:

See Table 2.

#### Ambient Temperature Limits:

-40 to 60 °C (-40 to 140 °F) (general-use type)  
-30 to 60 °C (-22 to 140 °F) (with integral indicator)  
(Note: The ambient temperature limits must be within the fill fluid operating temperature range, see table 1.)  
(See ‘Optional Specifications’ for Explosion-protected types)

#### Ambient Temperature Effect:

See Table 2.

#### Process Temperature Limits:

See Table 1.  
(See ‘Optional Specifications’ for Explosion-protected types)

#### Ambient Humidity Limits:

5 to 100 % R.H.(at 40 °C)

#### Working Pressure Limits:

2.7 kPa abs {20 mmHg abs} to max. measurement rangevalue.  
(Note: The working pressure must be within flange rating pressure.)

For atmospheric pressure or below, see Figure 2.

#### Power Supply Effect “◇”:

±0.005 %/V (21.6 to 32 V DC, 350 Ω)

#### Mounting:

Transmitter; 2-inch pipe mounting  
Diaphragm seal; flange mounting

**Mounting Flange Rating:**

See 'Model and Suffix Codes.'  
 Flange conforming to ANSI are serrated on the gasket surfaces (ANSI B16.5)  
 Note: For model EJA438W wetted parts material code H, T, or U, no serration is worked.

**Degrees of Protection:**

IP67, NEMA4X, JIS C0920 immersion proof

**Explosion-protected Construction:**

See 'Optional Specification.'

**Electrical Connection:**

See 'Model and Suffix Codes.'

**Amplifier Housing:**

Cast aluminum alloy or JIS SCS14A stainless steel (optional)

**Painting:**

Polyurethane resin baked finish  
 Deep sea moss green (Munsell 0.6GY3.1/2.0)

**Integral Indicator:**

LCD digital indicator (optional)

**Transmitter Material:**

Cover flange; JIS SCS14A  
 Cover flange bolts; See 'Model and Suffix Codes.'

**Diaphragm Seal Material:**

Diaphragm and other wetted parts;  
 See 'Model and Suffix Codes.'  
 Capillary tube; JIS SUS316  
 Protection tube; JIS SUS304  
 PVC-sheathed (Max. operating temperature of PVC, 100 °C (212 °F))  
 Fill fluid; See Table 1.

**Damping Time Constant:**

(Sum of time constants for amplifier assembly and capsule assembly with diaphragm seal)  
 Amplifier assembly time constant;  
 Can be set in 9 increments from 0.2 to 64 sec.  
 Capsule assembly time constant;

Capsule	A	B
Time Constant (sec)	Approx. 0.2	Approx. 0.2

T02E.EPS

Approximate values obtained at normal temperature when the capillary length is 5 m, process flange size/material code A, B, C and the fill fluid code is A.

**External Zero Adjustment “◇”:**

Continuously adjustable Resolution; 0.01 % of span

**Zero Adjustment Limits:**

Zero can be fully elevated or suppressed as long as low and high range values are within the measurement range low and high limits of the capsule.

**Tag Plate:**

JIS SUS304.

**Weight:**

8.3 kg (18.3 lb) Model EJA438W with 50 mm JIS 10K flange, capillary length 5 m; with integral indicator and mounting bracket.  
 13.4 kg (29.6 lb) Model EJA438N with 100 mm JIS 10K flange, X<sub>2</sub>=100, capillary length 5 m; with integral indicator and mounting bracket.  
 Add 1.4 kg (3.1 lb) for JIS SCS14A stainless steel amplifier housing.

**EMC Conformity Standards:** CE , N200

EN61326, AS/NZS CISPR11

**European Pressure Equipment Directive 97/23/EC:**

Sound Engineering Practice

< Settings When Shipped > “◇”

Tag Number	As specified in order *1
Output Mode	'Linear'
Display Mode	'Linear'
Operation Mode	'Normal' unless otherwise specified in order
Damping Time Constant	'2 sec.'

Calibration Range Lower Range Value	As specified in order
Calibration Range Higher Range Value	As specified in order
Calibration Range Units	Selected from mmH <sub>2</sub> O, mmAq, mmWG, mmHg, Pa, hPa, kPa, MPa, mbar, bar, gf/cm <sup>2</sup> , kgf/cm <sup>2</sup> , inH <sub>2</sub> O, inHg, ftH <sub>2</sub> O, or psi. (Only one unit can be specified)

\*1: Up to 16 alphanumeric characters (including - and ·) will be entered in the amplifier memory.

T05E.EPS

**Table 1. Process Temperature and Ambient Temperature**

	Silicone Oil			Fluorinated Oil	Ethylene Glycol
	Fill Fluid Code 'A'	Fill Fluid Code 'B'	Fill Fluid Code 'C'	Fill Fluid Code 'D'	Fill Fluid Code 'E'
Process Temperature *1	-10 to 250 °C (14 to 482 °F)	-30 to 180 °C (-22 to 356 °F)	10 to 300 °C (50 to 572 °F)	-20 to 120 °C (-4 to 248 °F)	-50 to 100 °C (-58 to 212 °F)
Ambient temperature *2	-10 to 60 °C (14 to 140 °F)	-15 to 60 °C (5 to 140 °F)	10 to 60 °C (50 to 140 °F)	-10 to 60 °C (14 to 140 °F)	-40 to 60 °C (-40 to 140 °F)
Working pressure	See Figure 2			51 kPa abs or more {380 mmHg abs}	Vacuum pressure not allowed
Specific gravity *3	1.07	0.94	1.09	1.90 to 1.92	1.09

- \*1: See Figure 2 'Working Pressure and Process Temperature.'
- \*2: This ambient temperature is the transmitter ambient temperature.
- \*3: Approximate values at a temperature of 25 °C (77 °F)
- \*4: The pressure transmitter should be installed at least 700 mm below the process connection. However, this value (700 mm) may be affected by ambient temperature, operating pressure, fill fluid or material of the wetted diaphragm. Contact YOKOGAWA when the transmitter can not be installed at least 700 mm below the process connection.

T06E.EPS

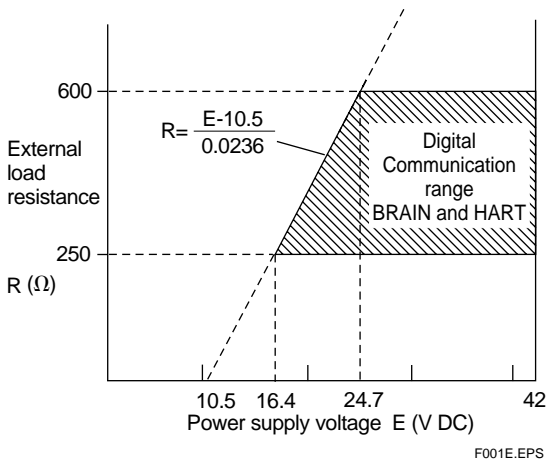

Figure 1. Relationship Between Power Supply Voltage and External Load Resistance

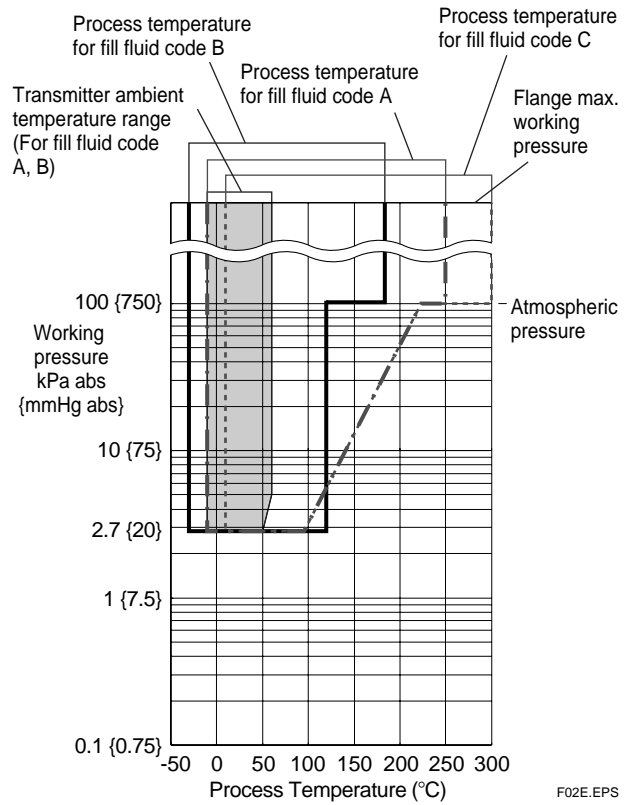

Figure 2. Working Pressure and Process Temperature

Table 2. Accuracy and Ambient Temperature Effect (As percent of 'x') \*1

Capsule		A, B (For wetted parts material code S)	A, B (For wetted parts material code H, T, and U)
Accuracy		± 0.2 % For x ≥ Pref ± (0.15 + 0.05 × $\frac{\text{Pref}}{x}$ ) % For x < Pref	± 0.2 % For x ≥ Pref ± (0.15 + 0.05 × $\frac{\text{Pref}}{x}$ ) % For x < Pref
Ambient temperature effect *2	Zero shift	± (0.2 + 0.5 × $\frac{\text{Pref}}{x}$ ) % / 50 °C	± (0.3 + 0.6 × $\frac{\text{Pref}}{x}$ ) % / 50 °C
	Total shift	± 1.4 % / 50 °C For x ≥ Pref ± (0.7 + 0.7 × $\frac{\text{Pref}}{x}$ ) % / 50 °C For x < Pref	± 1.6 % / 50 °C For x ≥ Pref ± (0.8 + 0.8 × $\frac{\text{Pref}}{x}$ ) % / 50 °C For x < Pref

\*1: 'x' is the highest value among the absolute value of the lower range value (LRV) and higher range value (HRV), and the span value in a calibration range.

$$\text{Percent of span} = \text{Percent of } x \times \frac{x}{\text{span}}$$

\*2: In case of 6 to 10 m. for capillary length, value of ambient temperature effect is twice that given in the table. The ambient temperature effect specification applies to the range of 0 to 60 °C (32 to 140 °F). (Below 0 °C (32 °F), value is three times that given in the table.)

Table 3. Value of 'Pref'

Capsule	Pref
A	0.3 MPa { 3 kgf/cm <sup>2</sup> }
B	1.4 MPa { 14 kgf/cm <sup>2</sup> }

T008E.EPS

**MODEL AND SUFFIX CODES**

● **Model EJA438W [Flange size: 2-inch (50 mm) and 3-inch (80 mm)]**

Model	Suffix Codes	Description
<b>EJA438W</b>	.....	Diaphragm Sealed Gauge Pressure transmitter (Flush diaphragm type)
Output Signal	-D ..... -E ..... -F .....	4 to 20 mA DC with digital communication (BRAIN protocol) 4 to 20 mA DC with digital communication (HART protocol) *1 Digital communication (FOUNDATION Fieldbus protocol) *6
Measurement span (capsule)	A ..... B .....	0.06 to 3 MPa {0.6 to 30 kgf/cm <sup>2</sup> } {8.6 to 430 psi} {0.6 to 30 bar} 0.46 to 14 MPa {4.6 to 140 kgf/cm <sup>2</sup> } {66 to 2000 psi} {4.6 to 140 bar}
Wetted parts material *8	S ..... H ..... T ..... U .....	[Diaphragm] [Others] JIS SUS316L JIS SUS316L Hastelloy C-276 *9 Hastelloy C-276 *9 Tantalum Tantalum Titanium Titanium
Process flange rating	J1 ..... J2 ..... J4 ..... J6 ..... A1 ..... A2 ..... A4 ..... P1 ..... P2 ..... P4 ..... D2 ..... D4 ..... D5 .....	JIS 10K JIS 20K JIS 40K JIS 63K ANSI Class 150 ANSI Class 300 ANSI Class 600 JPI Class 150 JPI Class 300 JPI Class 600 DIN PN10/16 DIN PN25/40 DIN PN64
Process flange size / material ☆	A ..... B ..... C ..... D ..... E ..... F .....	2-inch (50 mm) / JIS S25C 2-inch (50 mm) / JIS SUS304 2-inch (50 mm) / JIS SUS316 3-inch (80 mm) / JIS S25C 3-inch (80 mm) / JIS SUS304 3-inch (80 mm) / JIS SUS316
Cover flange bolts material ☆	A ..... B .....	JIS SCM435 JIS SUS630
Fill fluid ☆	-A *2 ..... -B *3 ..... -C ..... -D *4 ..... -E .....	[Process temp.] [Ambient temp.] For general use (silicone oil) -10 to 250 °C -10 to 60 °C For general use (silicone oil) -30 to 180 °C -15 to 60 °C For high temperature use (silicone oil) 10 to 300 °C 10 to 60 °C For oil-prohibited use (fluorinated oil) -20 to 120 °C -10 to 60 °C For low temperature use (ethylene glycol) -50 to 100 °C -40 to 60 °C
	A .....	Always A
Capillary length (m)	<input type="checkbox"/> <input type="checkbox"/> *5 .....	Specify capillary length from 1 to 10 m in <input type="checkbox"/> <input type="checkbox"/> . (Example for 2 m : 02)
Installation	-9 .....	Horizontal impulse piping type, left side high pressure
Electrical connection ☆	0 ..... 2 ..... 3 ..... 4 ..... 5 ..... 7 ..... 8 ..... 9 .....	G1/2 female, one electrical connection 1/2 NPT female, two electrical connections without blind plug Pg 13.5 female, two electrical connections without blind plug M20 female, two electrical connections without blind plug G1/2 female, two electrical connections and a blind plug 1/2 NPT female, two electrical connections and a blind plug Pg 13.5 female, two electrical connections and a blind plug M20 female, two electrical connections and a blind plug
Integral indicator ☆	D ..... E ..... N .....	Digital indicator Digital indicator with the range setting switch *7 (None)
Mounting bracket ☆	A ..... B ..... N .....	JIS SECC 2-inch pipe mounting (flat type) JIS SUS304 2-inch pipe mounting (flat type) (None)
Optional codes	<input type="checkbox"/> Optional specification	

T09E.EPS

The '☆' marks indicate the most typical selection for each specification. Example: EJA438W-DASA1AA-AA02-92NA/□

- 
- \*1: Refer to GS 01C22T01-00E for HART Protocol version.
  - \*2: In case of Wetted parts material code T (Tantalum), the process temperature limit is -10 to 200 °C.
  - \*3: Wetted parts material code T (Tantalum) cannot be applied.
  - \*4: Even in case where Fill fluid code D (fluorinated oil) is selected, if degrease cleansing treatment or both degrease cleansing and dehydrating treatment for the wetted parts is required, specify Optional code K1 or K5.
  - \*5: In case of Wetted parts material code H (Hastelloy C), T (Tantalum), and U (Titanium) or Fill fluid code C (for high temperature use), specify capillary length from 1 to 5 m.
  - \*6: Refer to GS 01C22T02-00E for Fieldbus communication.
  - \*7: Not applicable for Output signal code F.
  - \*8:  Users must consider the characteristics of selected wetted parts material and the influence of process fluids. The use of inappropriate materials can result in the leakage of corrosive process fluids and cause injury to personnel and/or damage to plant facilities. It is also possible that the diaphragm itself can be damaged and that material from the broken diaphragm and the fill fluid can contaminate the user's process fluids.  
Be very careful with highly corrosive process fluids such as hydrochloric acid, sulfuric acid, hydrogen sulfide, sodium hypochlorite, and high-temperature steam (150°C [302°F] or above). Contact Yokogawa for detailed information of the wetted parts material.
  - \*9: Hastelloy C-276 or ASTM N10276.

● Model EJA438N [Flange size: 4-inch (100 mm)]

Model	Suffix Codes	Description
<b>EJA438N</b>	.....	Diaphragm sealed gauge pressure transmitter (Extended diaphragm type)
Output Signal	-D..... -E..... -F.....	4 to 20 mA DC with digital communication (BRAIN protocol) 4 to 20 mA DC with digital communication (HART protocol) *1 Digital communication (FOUNDATION Fieldbus protocol) *4
Measurement span (capsule)	A..... B.....	0.06 to 3 MPa {0.6 to 30 kgf/cm <sup>2</sup> } {8.6 to 430 psi} {0.6 to 30 bar} 0.46 to 7 MPa {4.6 to 70 kgf/cm <sup>2</sup> } {66 to 1000 psi} {4.6 to 70 bar}
Wetted parts material *7	S.....	[Diaphragm] [Pipe] [Others] JIS SUS316L JIS SUS316 JIS SUS316
Flange rating	J1..... J2..... J4..... A1..... A2..... P1..... P2..... D2..... D4.....	JIS 10K JIS 20K JIS 40K ANSI Class 150 ANSI Class 300 JPI Class 150 JPI Class 300 DIN PN10/16 DIN PN25/40
Diaphragm extension length	2..... 4..... 6.....	X <sub>2</sub> = 50 mm X <sub>2</sub> = 100 mm X <sub>2</sub> = 150 mm
Process flange size / material ☆	G..... H..... J.....	4-inch (100 mm) / JIS S25C 4-inch (100 mm) / JIS SUS304 4-inch (100 mm) / JIS SUS316
Cover flange bolts material ☆	A..... B.....	JIS SCM435 JIS SUS630
Fill fluid ☆	-A..... -B..... -C..... -D *2..... -E..... B.....	[Process tempe.] [Ambient tempe.] For general use (silicone oil) -10 to 250 °C -10 to 60 °C For general use (silicone oil) -30 to 180 °C -15 to 60 °C For high temperature use (silicone oil) 10 to 300 °C 10 to 60 °C For oil-prohibited use (fluorinated oil) -20 to 120 °C -10 to 60 °C For low temperature use (ethylene glycol) -50 to 100 °C -40 to 60 °C Always B
Capillary length (m) *3 *5	<input type="checkbox"/> <input type="checkbox"/> .....	Specify capillary length from 1 to 10 m in <input type="checkbox"/> <input type="checkbox"/> . (Example for 2 m : 02)
Installation	-9.....	Horizontal impulse piping type, left side high pressure
Electrical connection ☆	0..... 2..... 3..... 4..... 5..... 7..... 8..... 9.....	G1/2 female, one electrical connection 1/2 NPT female, two electrical connections without blind plug Pg 13.5 female, two electrical connections without blind plug M20 female, two electrical connections without blind plug G1/2 female, two electrical connections and a blind plug 1/2 NPT female, two electrical connections and a blind plug Pg 13.5 female, two electrical connections and a blind plug M20 female, two electrical connections and a blind plug
Integral indicator ☆	D..... E..... N.....	Digital indicator Digital indicator with the range setting switch *6 (None)
Mounting bracket ☆	A..... B..... N.....	JIS SECC 2-inch pipe mounting (flat type) JIS SUS304 2-inch pipe mounting (flat type) (None)
Optional codes		<input type="checkbox"/> Optional specification

T10E.EPS

The '☆' marks indicate the most typical selection for each specification. Example: EJA438N-DASA12GA-AB02-92NA/

- \*1: Refer to GS 01C22T01-00E for HART Protocol version.
- \*2: Even in case where Fill fluid code D (fluorinated oil) is selected, if degrease cleansing treatment or both degrease cleansing and dehydrating treatment for the wetted parts is required, specify Optional code K1 or K5.
- \*3: In case of Fill fluid code C (for high temperature use), specify capillary length from 1 to 5 m.
- \*4: Refer to GS 01C22T02-00E for Fieldbus communication.
- \*5: The specified capillary length includes the diaphragm extension length(X<sub>2</sub>) and the flange thickness(t).
- \*6: Not applicable for Output signal code F.
- \*7:  Users must consider the characteristics of selected wetted parts material and the influence of process fluids. The use of inappropriate materials can result in the leakage of corrosive process fluids and cause injury to personnel and/or damage to plant facilities. It is also possible that the diaphragm itself can be damaged and that material from the broken diaphragm and the fill fluid can contaminate the user's process fluids.  
Be very careful with highly corrosive process fluids such as hydrochloric acid, sulfuric acid, hydrogen sulfide, sodium hypochlorite, and high-temperature steam (150°C [302°F] or above). Contact Yokogawa for detailed information of the wetted parts material.

● Model EJA438N [Flange size: 3-inch (80mm)]

Model	Suffix Codes	Description
<b>EJA438N</b>	.....	Diaphragm sealed gauge pressure transmitter (Extended diaphragm type)
Output Signal	-D ..... -E ..... -F .....	4 to 20 mA DC with digital communication (BRAIN protocol) 4 to 20 mA DC with digital communication (HART protocol) *1 Digital communication (FOUNDATION Fieldbus protocol) *2
Measurement span (capsule)	A ..... B .....	0.06 to 3 MPa {0.6 to 30 kgf/cm <sup>2</sup> } {8.6 to 430 psi} {0.6 to 30 bar} 0.46 to 7 MPa {4.6 to 70 kgf/cm <sup>2</sup> } {66 to 1000 psi} {4.6 to 70 bar}
Wetted parts material *5	S .....	[Diaphragm] [Pipe] [Others] JIS SUS316L JIS SUS316 JIS SUS316
Flange rating	J1 ..... J2 ..... J4 ..... A1 ..... A2 ..... P1 ..... P2 ..... D2 ..... D4 .....	JIS 10K JIS 20K JIS 40K ANSI Class 150 ANSI Class 300 JPI Class 150 JPI Class 300 DIN PN10/16 DIN PN25/40
Diaphragm extension length	2 ..... 4 ..... 6 .....	X <sub>2</sub> =50 mm X <sub>2</sub> =100 mm X <sub>2</sub> =150 mm
Process flange size / material ☆	D ..... E ..... F .....	3-inch (80 mm) / JIS S25C 3-inch (80 mm) / JIS SUS304 3-inch (80 mm) / JIS SUS316
Cover flange bolts material ☆	A ..... B .....	JIS SCM435 JIS SUS630
Fill fluid ☆	-A ..... -B ..... B .....	[Process temp.] [Ambient temp.] For general use (silicone oil) -10 to 250 °C -10 to 60 °C For general use (silicone oil) -30 to 180 °C -15 to 60 °C Always B
Capillary length (m) *3	<input type="checkbox"/> <input type="checkbox"/> .....	Specify capillary length from 1 to 5 m in <input type="checkbox"/> <input type="checkbox"/> . (Example for 2 m : 02)
Installation	-9 .....	Horizontal impulse piping type, left side high pressure
Electrical connection ☆	0 ..... 2 ..... 3 ..... 4 ..... 5 ..... 7 ..... 8 ..... 9 .....	G1/2 female, one electrical connection 1/2 NPT female, two electrical connections without blind plug Pg 13.5 female, two electrical connections without blind plug M20 female, two electrical connections without blind plug G1/2 female, two electrical connections and a blind plug 1/2 NPT female, two electrical connections and a blind plug Pg 13.5 female, two electrical connections and a blind plug M20 female, two electrical connections and a blind plug
Integral indicator ☆	D ..... E ..... N .....	Digital indicator Digital indicator with the range setting switch *4 (None)
Mounting bracket ☆	A ..... B ..... N .....	JIS SECC 2-inch pipe mounting (flat type) JIS SUS304 2-inch pipe mounting (flat type) (None)
Optional codes	<input type="checkbox"/> Optional specification	

The '☆' marks indicate the most typical selection for each specification. Example: EJA438N-DASA12DA-AB02-92NA/

T11E.EPS

\*1: Refer to GS 01C22T01-00E for HART Protocol version.

\*2: Refer to GS 01C22T02-00E for Fieldbus communication.

\*3: The specified capillary length includes the diaphragm extension length(X<sub>2</sub>) and the flange thickness(t).

\*4: Not applicable for Output signal code F.

\*5:  Users must consider the characteristics of selected wetted parts material and the influence of process fluids. The use of inappropriate materials can result in the leakage of corrosive process fluids and cause injury to personnel and/or damage to plant facilities. It is also possible that the diaphragm itself can be damaged and that material from the broken diaphragm and the fill fluid can contaminate the user's process fluids.  
Be very careful with highly corrosive process fluids such as hydrochloric acid, sulfuric acid, hydrogen sulfide, sodium hypochlorite, and high-temperature steam (150°C [302°F] or above). Contact Yokogawa for detailed information of the wetted parts material.

**OPTIONAL SPECIFICATIONS (For Explosion Protected Types “◇”)**

For FOUNDATION Fieldbus explosion protected type, see GS 01C22T02-00E.

Item	Description	Code
Factory Mutual (FM)	FM Explosionproof Approval *1 *3 Applicable standard: FM3600, FM3615, FM3810, ANSI/NEMA250 Explosionproof for Class I, Division 1, Groups B, C and D Dust-ignitionproof for Class II/III, Division 1, Groups E, F and G Hazardous (classified) locations, indoors and outdoors (NEMA 4X) Division 2, 'SEALS NOT REQUIRED', Temp. Class: T6 Amb. Temp.: -40 to 60°C (-40 to 140°F)	<b>FF1</b>
	FM Intrinsically safe Approval *1 *3 Applicable standard: FM3600, FM3610, FM3611, FM3810, ANSI/NEMA250 Intrinsically Safe for Class I, Division 1, Groups A, B, C & D, Class II, Division 1, Groups E, F & G and Class III, Division 1 Hazardous Locations. Nonincendive for Class I, Division 2, Groups A, B, C & D, Class II, Division. 2, Groups E, F & G, and Class III, Division 1 Hazardous Locations. Enclosure: "NEMA 4X", Temp. Class: T4, Amb. Temp.: -40 to 60°C (-40 to 140°F) Intrinsically Safe Apparatus Parameters [Groups A, B, C, D, E, F and G] Vmax=30 V, Imax=165 mA, Pmax=0.9 W, Ci=22.5 nF, Li=730 μH [Groups C, D, E, F and G] Vmax=30 V, Imax=225 mA, Pmax=0.9 W, Ci=22.5 nF, Li=730 μH	<b>FS1</b>
	Combined FF1 and FS1 *1 *3	<b>FU1</b>
CENELEC ATEX	CENELEC ATEX (KEMA) Flameproof Approval *2 *3 Applicable standard: EN50014, EN50018, EN50281-1-1 Certificate: KEMA 02ATEX2148 II 2G EExd IIC T4, T5, T6 Amb. Temp.: T5; -40 to 80°C (-40 to 176°F), T4 and T6; -40 to 75°C (-40 to 167°F) Max. process Temp.: T4; 120°C (248°F), T5; 100°C (212°F), T6; 85°C (185°F)	<b>KF2</b>
	CENELEC ATEX (KEMA) Intrinsically safe Approval *2 *3 Applicable standard: EN50014, EN50020, EN500284, EN50281-1-1 Certificate: KEMA 02ATEX1030X II 1G EEx ia IIC T4, Amb. Temp.: -40 to 60°C (-40 to 140°F) Ui=30 V, Ii=165 mA, Pi=0.9 W, Ci=22.5 nF, Li=730 μH	<b>KS2</b>
	Combined KF2, KS2 and Type n *2 *3 Type n Applicable standard: EN50021 II 3G Ex nL IIC T4, Amb. Temp.: -40 to 60°C (-40 to 140°F) Ui=30 V DC, Ci=22.5 nF, Li=730 μH Dust II 1D maximum surface temperature T65°C (149°F) {Tamb.: 40°C (104°F)}, T85°C (185°F) {Tamb.: 60°C (140°F)}, T105°C (221°F) {Tamb.: 80°C (176°F)}	<b>KU2</b>

T14E.EPS

\*1: Applicable for Electrical connection code 2 and 7 (1/2 NPT female).

\*2: Applicable for Electrical connection code 2, 4, 7 and 9 (1/2 NPT and M20 female).

\*3: Applicable for Output signal code D and E. For intrinsically safe approval, use the safety barrier certified by the testing laboratories (BARD-400 is not applicable).

Item	Description	Code
Canadian Standards Association (CSA)	CSA Explosionproof Approval *1 *3 Applicable standard: C22.2 No. 0, No. 0.4, No. 25, No. 30, No. 94, No. 142 Certificate: 1089598 Explosionproof for Class I, Division 1, Groups B, C and D Dustignitionproof for Class II/III, Division 1, Groups E, F and G Division2 'SEALS NOT REQUIRED' , Temp. Class: T4, T5, T6 Encl Type 4x Max. Process Temp.: T4; 120°C (248°F), T5; 100°C (212°F), T6; 85°C (185°F) Amb. Temp.: -40 to 80°C (-40 to 176°F)	CF1
	CSA Intrinsically safe Approval *1 *3 Applicable standard: C22.2 No. 0, No. 0.4, No. 25, No. 30, No. 94, No. 142, No. 157, No. 213 Certificate: 1053843 Class I, Groups A, B, C and D Class II and III, Groups E, F and G Encl Type 4x, Temp. Class: T4, Amb. Temp.: -40 to 60°C (-40 to 140°F) Vmax=30 V, Imax=165 mA, Pmax=0.9 W, Ci=22.5 nF, Li=730 μH	CS1
	Combined CF1 and CS1 *1 *3	CU1
IECEX Scheme *4	IECEX Intrinsically safe, type n and Flameproof Approval *3 *9 Intrinsically safe and type n Applicable Standard: IEC 60079-0:2004, IEC 60079-11:1999, IEC 60079-15:2005, IEC 60079-26:2005 Certificate: IECEX KEM 06.0007X Ex ia IIC T4, Ex nL IIC T4 Enclosure: IP67 Amb. Temp.: -40 to 60°C (-40 to 140°F), Max. Process Temp.: 120°C (248°F) Electrical Parameters: [Ex ia] Ui=30 V, Ii=165 mA, Pi=0.9 W, Ci=22.5 nF, Li=730 μH [Ex nL] Ui=30 V, Ci=22.5 nF, Li=730 μH  Flameproof Applicable Standard: IEC 60079-0:2004, IEC60079-1:2003 Certificate: IECEX KEM 06.0005 Ex d IIC T6...T4 Enclosure: IP67 Max.Process Temp.: T4:120°C (248°F), T5;100°C (212°F), T6; 85°C (185°F) Amb.Temp.: -40 to 75°C (-40 to 167°F) for T4, -40 to 80°C (-40 to 176°F) for T5, -40 to 75°C (-40 to 167°F) for T6	SU2
TIIS certification	TIIS Flameproof Approval, Ex do IIC T4X *3 *5 *7 *8 Certificate: C15296 (Without integral indicator) C15297 (With integral indicator) Amb. Temp.: -20 to 60°C, Process Temp.: -20 to 120°C	FS3
	TIIS Intrinsically safe Approval, Ex ia IIC T4 *6 *8 Certificate: C14632 Amb. Temp.: -20 to 60°C, Process Temp.: -20 to 120°C	JS3
Attached flameproof packing adapter *5	Electrical connection: G1/2 female Applicable cable: O. D. 8 to 12 mm	1 pc.
		2 pcs.
		G11
		G12

T16E.EPS

- \*1: Applicable for Electrical connection code 2 and 7 (1/2 NPT female).
- \*2: Applicable for Electrical connection code 2, 4, 7 and 9 (1/2 NPT and M20 female).
- \*3: Applicable for Output signal code D and E. For intrinsically safe approval, use the safety barrier certified by the testing laboratories (BARD-400 is not applicable).
- \*4: Applicable only for Australia and New Zealand area.
- \*5: If cable wiring is to be used to a TIIS flameproof type transmitter, add the YOKOGAWA-assured flameproof packing adapter.
- \*6: Applicable for Output signal code D. See <Safety Barrier for TIIS Intrinsically Safe Type>.
- \*7: In case that the ambient temperature exceeds 50°C or that the ambient temperature exceeds 45°C with the process temperature of 90°C or above, use heat-resistant cables with maximum allowable temperature of 75°C or above.
- \*8: TIIS (The Technology Institution of Industrial Safety) Certification is a new notation for the explosionproof approval in Japan instead of JIS.
- \*9: Applicable for Electrical connection code 2, 4 and 7 (1/2 NPT and M20 female).

**OPTIONAL SPECIFICATIONS**

Item		Description	Code
Painting *8	Color change	Amplifier cover only	P□
		Amplifier cover and terminal cover, Munsell 7.5 R4/14	PR
	Coating change	Epoxy resin-baked coating *9	X1
Lightning protector		Transmitter power supply voltage : 10.5 to 32 V DC ( 10.5 to 28 V DC for TIIS intrinsically safe type, 10.5 to 30 V DC for intrinsically safe type other than TIIS, or 9 to 32 V DC for Fieldbus communication type.) Allowable current : Max. 6000 A (1×40 μs), Repeating 1000 A (1×40 μs) 100 times	A
Oil-prohibited use		Degrease cleansing treatment	K1
Oil-prohibited use with dehydrating treatment		Degrease cleansing treatment and dehydrating treatment	K5
No serration *1		No serration work on the flange gasket surface ( for ANSI flange only )	Q
Teflon film		Diaphragm protection from sticky process fluid by FEP Teflon film attached with fluorinated oil. Operation range: 20 to 150°C, 0 to 2 MPa(Not applicable for vacuum service).	T
Operating temperature correction *2		Adjusting range : 80°C to Maximum temperature of specified fill fluid	R
Fast response *6		Update time: 0.125 sec or less Amplifier assembly damping time constant: 0.1 to 64 sec in 9 increments. Response time (with min. damping time constant): max. 0.3 sec (excluding diaphragm seal units)	F1
Failure alarm down-scale *3		Output status at CPU failure and hardware error is -5%, 3.2 mA or less.	C1
NAMUR NE43 compliant *3 *7	Output signal limits: 3.8 mA to 20.5 mA	Failure alarm down-scale: output status at CPU failure and hardware error is -5%, 3.2 mA or less.	C2
		Failure alarm up-scale: output status at CPU failure and hardware error is 110%, 21.6 mA or more.	C3
Stainless steel amplifier housing *4		Amplifier housing material : JIS SCS14A stainless steel (equivalent to JIS SUS316 cast stainless steel or ASTM CF-8M)	E1
Gold-plate		Inside of isolating diaphragms(fill fluid side) are gold plated, effective for hydrogen permeation. ( applicable for Wetted parts material code S and H )	A1
Stainless steel tag plate		304SST tag plate wired onto transmitter	N4
Capillary without PVC sheaths		When ambient temperature exceeds 100°C, or use of PVC is prohibited	V
Calibration units *5	P calibration ( psi unit )		D1
	bar calibration ( bar unit )		D3
	M calibration (kgf/cm <sup>2</sup> unit )		D4
Sealing treatment to JIS SUS630 nuts		Sealant(liquid silicone rubber) is coated on JIS SUS630 cover flange mounting nuts against stress corrosion cracking.	Y

T13E.EPS

- \*1: This item cannot be applied to model EJA438W Wetted part material code H, T, or U, whose gasket contact surface are not serrated as standard specifications.
- \*2: Specify the process operating temperature for zero correction. Example: Zero correction by process temperature 90°C.
- \*3: Applicable for Output signal code D and E. The hardware error indicates faulty amplifier or capsule. When combining with Option code F1, output status for down-scale is -2.5%, 3.6 mA DC or less.
- \*4: Applicable for Electrical connection code 2, 3, 4, and 7. Not applicable for Option code P□ and X1.
- \*5: The unit of MWP (Max. working pressure) on name plate of a housing is the same unit as specified by Option code D1, D3, and D4.
- \*6: Applicable for Output signal code D and E.
- \*7: Not applicable for Option code C1.
- \*8: Standard polyurethan painting can be used in acid atmosphere, whereas the epoxy resin-baked coating (Option code X1) can be used in alkaline atmosphere. Anti-corrosion coating, the combination of polyurethan and epoxy resin-baked coating, is available by special order as sea water, alkaline, and acid resistant.
- \*9: Not applicable for color change option.

**Table 4. Calibration Units**

	Measurement Span and Range	Optional Code			
		D1 ( psi Unit )	D3 ( bar Unit )	D4 ( kgf/cm <sup>2</sup> Unit )	
EJA438W	A	Span	8.6 to 430 psi	0.6 to 30 mbar	0.6 to 30 kgf/cm <sup>2</sup>
		Range	-15 to 430 psi	-1 to 30 mbar	-1 to 30 kgf/cm <sup>2</sup>
	B	Span	66 to 2000 psi	4.6 to 140 mbar	4.6 to 140 kgf/cm <sup>2</sup>
		Range	-15 to 2000 psi	-1 to 140 mbar	-1 to 140 kgf/cm <sup>2</sup>

	Measurement Span and Range	Optional Code			
		D1 ( psi Unit )	D3 ( bar Unit )	D4 ( kgf/cm <sup>2</sup> Unit )	
EJA438N	A	Span	8.6 to 430 psi	0.6 to 30 mbar	0.6 to 30 kgf/cm <sup>2</sup>
		Range	-15 to 430 psi	-1 to 30 mbar	-1 to 30 kgf/cm <sup>2</sup>
	B	Span	66 to 1000 psi	4.6 to 70 mbar	4.6 to 70 kgf/cm <sup>2</sup>
		Range	-15 to 1000 psi	-1 to 70 mbar	-1 to 70 kgf/cm <sup>2</sup>

T12E.EPS

Item	Description			Code		
Mill Certificate	Process flange, Block	For model EJA438W		<b>M05</b>		
	Process flange, Block, Pipe, Base	For model EJA438N		<b>M06</b>		
Pressure test/Leak test Certificate *1	For A-capsule	( Flange rating )	( Test Pressure )	(Applicable model)		
		JIS 10K	2 MPa {20 kgf/cm <sup>2</sup> }	EJA438W/EJA438N	<b>T41</b>	
		JIS 20K	3 MPa {30 kgf/cm <sup>2</sup> }		<b>T42</b>	
		JIS 40K	3 MPa {30 kgf/cm <sup>2</sup> }		<b>T43</b>	
		JIS 63K	3 MPa {30 kgf/cm <sup>2</sup> }	EJA438W	<b>T45</b>	
		ANSI/JPI Class 150	3 MPa {29.8 kgf/cm <sup>2</sup> }	EJA438W/EJA438N	<b>T46</b>	
		ANSI/JPI Class 300	3 MPa {30 kgf/cm <sup>2</sup> }		<b>T47</b>	
	ANSI/JPI Class 600	3 MPa {30 kgf/cm <sup>2</sup> }	EJA438W	<b>T49</b>		
	For B-capsule	JIS 10K	2 MPa {20 kgf/cm <sup>2</sup> }	EJA438W/EJA438N	<b>T31</b>	
		JIS 20K	5 MPa {50 kgf/cm <sup>2</sup> }		<b>T32</b>	
		JIS 40K	10 MPa {100 kgf/cm <sup>2</sup> }	EJA438W	<b>T33</b>	
		JIS 40K	7 MPa {70 kgf/cm <sup>2</sup> }	EJA438N	<b>T34</b>	
		JIS 63K	14 MPa {140 kgf/cm <sup>2</sup> }	EJA438W	<b>T35</b>	
		ANSI/JPI Class 150	3 MPa {29.8 kgf/cm <sup>2</sup> }	EJA438W/EJA438N	<b>T36</b>	
		ANSI/JPI Class 300	7.7 MPa {77 kgf/cm <sup>2</sup> }	EJA438W	<b>T37</b>	
		ANSI/JPI Class 300	7 MPa {70 kgf/cm <sup>2</sup> }	EJA438N	<b>T38</b>	
		ANSI/JPI Class 600	14 MPa {140 kgf/cm <sup>2</sup> }	EJA438W	<b>T39</b>	
		Nitrogen (N <sub>2</sub> ) Gas *2				
		Retention time: 10 minutes				

T15E.EPS

- \*1: The unit on the certificate is always MPa regardless of selection of option code D1, D3, or D4.
- \*2: Pure nitrogen gas is used for oil-prohibited use (Option code K1 and K5).

**DIMENSIONS**

● **Model EJA438W**

Unit : mm (approx. inch)

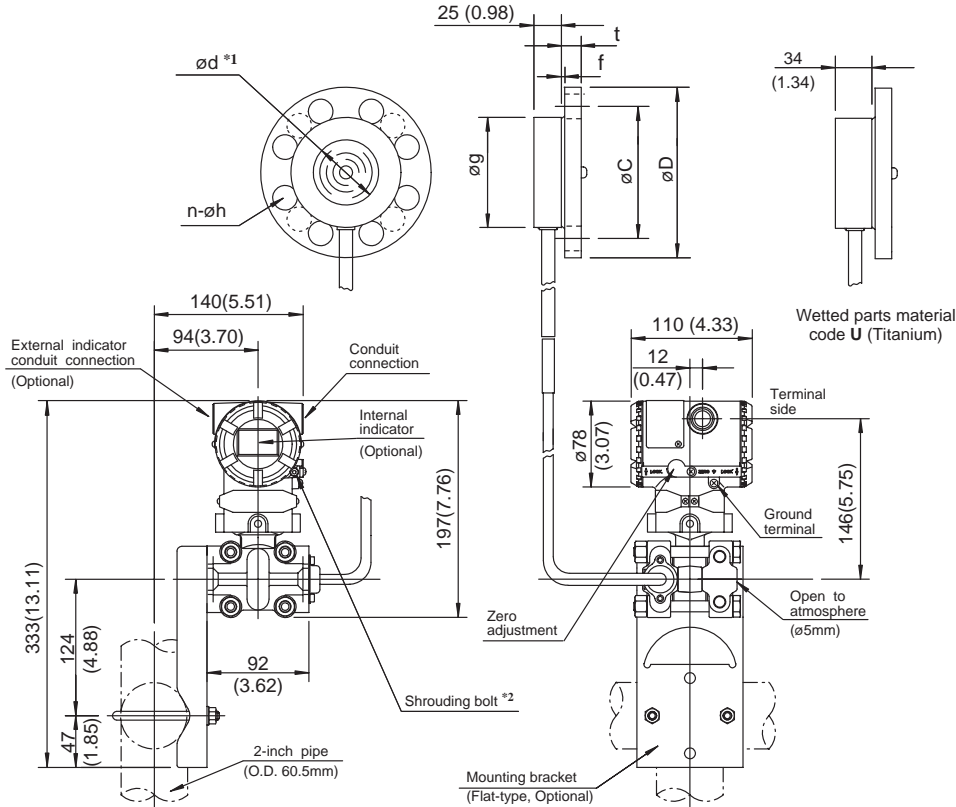

\*1: Indicates inside diameter of gasket contact surface.  
 \*2: Applicable only for ATEX, IECEx, and IIIS Flameproof type.

**Process flange size : 3 inch (80 mm)**

Flange Rating	øD	øC	øg	ød	t	f*	n	øh
JIS 10K	185(7.28)	150(5.91)	130(5.12)	90(3.54)	18(0.71)	0	8	19(0.75)
JIS 20K	200(7.87)	160(6.30)	130(5.12)	90(3.54)	22(0.87)	0	8	23(0.91)
JIS 40K	210(8.27)	170(6.69)	130(5.12)	90(3.54)	32(1.26)	0	8	23(0.91)
JIS 63K	230(9.06)	185(7.28)	130(5.12)	90(3.54)	40(1.57)	0	8	25(0.98)
ANSI Class 150	190.5(7.50)	152.4(6)	130(5.12)	90(3.54)	23.9(0.94)	1.6(0.06)	4	19.1(0.75)
ANSI Class 300	209.6(8.25)	168.1(6.62)	130(5.12)	90(3.54)	28.5(1.12)	1.6(0.06)	8	22.4(0.88)
ANSI Class 600	209.6(8.25)	168.1(6.62)	130(5.12)	90(3.54)	38.2(1.50)	6.4(0.25)	8	22.4(0.88)
JPI Class 150	190(7.48)	152.4(6)	130(5.12)	90(3.54)	24(0.94)	1.6(0.06)	4	19(0.75)
JPI Class 300	210(8.27)	168.1(6.62)	130(5.12)	90(3.54)	28.5(1.12)	1.6(0.06)	8	22(0.87)
JPI Class 600	210(8.27)	168.1(6.62)	130(5.12)	90(3.54)	38.4(1.51)	6.4(0.25)	8	22(0.87)
DIN PN 10/16	200(7.78)	160(6.30)	130(5.12)	90(3.54)	20(0.79)	0	8	18(0.71)
DIN PN 25/40	200(7.78)	160(6.30)	130(5.12)	90(3.54)	24(0.94)	0	8	18(0.71)
DIN PN 64	215(8.46)	170(6.69)	130(5.12)	90(3.54)	28(1.10)	0	8	22(0.87)

**Process flange size : 2 inch (50 mm)**

Flange Rating	øD	øC	øg	ød	t	f*	n	øh
JIS 10K	155(6.10)	120(4.72)	100(3.94)	61(2.40)	16(0.63)	0	4	19(0.75)
JIS 20K	155(6.10)	120(4.72)	100(3.94)	61(2.40)	18(0.71)	0	8	19(0.75)
JIS 40K	165(6.50)	130(5.12)	100(3.94)	61(2.40)	26(1.02)	0	8	19(0.75)
JIS 63K	185(7.28)	145(5.12)	100(3.94)	61(2.40)	34(1.34)	0	8	23(0.91)
ANSI Class 150	152.4(6.00)	120.7(4.75)	100(3.94)	61(2.40)	19.1(0.75)	1.6(0.06)	4	19.1(0.75)
ANSI Class 300	165.1(6.50)	127.0(5.00)	100(3.94)	61(2.40)	22.4(0.88)	1.6(0.06)	8	19.1(0.75)
ANSI Class 600	165.1(6.50)	127.0(5.00)	100(3.94)	61(2.40)	31.8(1.25)	6.4(0.25)	8	19.1(0.75)
JPI Class 150	152(6.10)	120.6(4.75)	100(3.94)	61(2.40)	19.5(0.77)	1.6(0.06)	4	19(0.75)
JPI Class 300	165(6.50)	127.0(5.00)	100(3.94)	61(2.40)	22.5(0.89)	1.6(0.06)	8	19(0.75)
JPI Class 600	165(6.50)	127.0(5.00)	100(3.94)	61(2.40)	31.9(1.26)	6.4(0.25)	8	19(0.75)
DIN PN 10/16	165(6.50)	125(4.92)	100(3.94)	61(2.40)	18(0.71)	0	4	18(0.71)
DIN PN 25/40	165(6.50)	125(4.92)	100(3.94)	61(2.40)	20(0.78)	0	4	18(0.71)
DIN PN 64	180(7.09)	135(5.31)	100(3.94)	61(2.40)	26(1.02)	0	4	22(0.87)

\* In case where process flange material is JIS S25C, value of f is 0.

F03E.EPS

● Model EJA438N

Unit : mm (approx. inch)

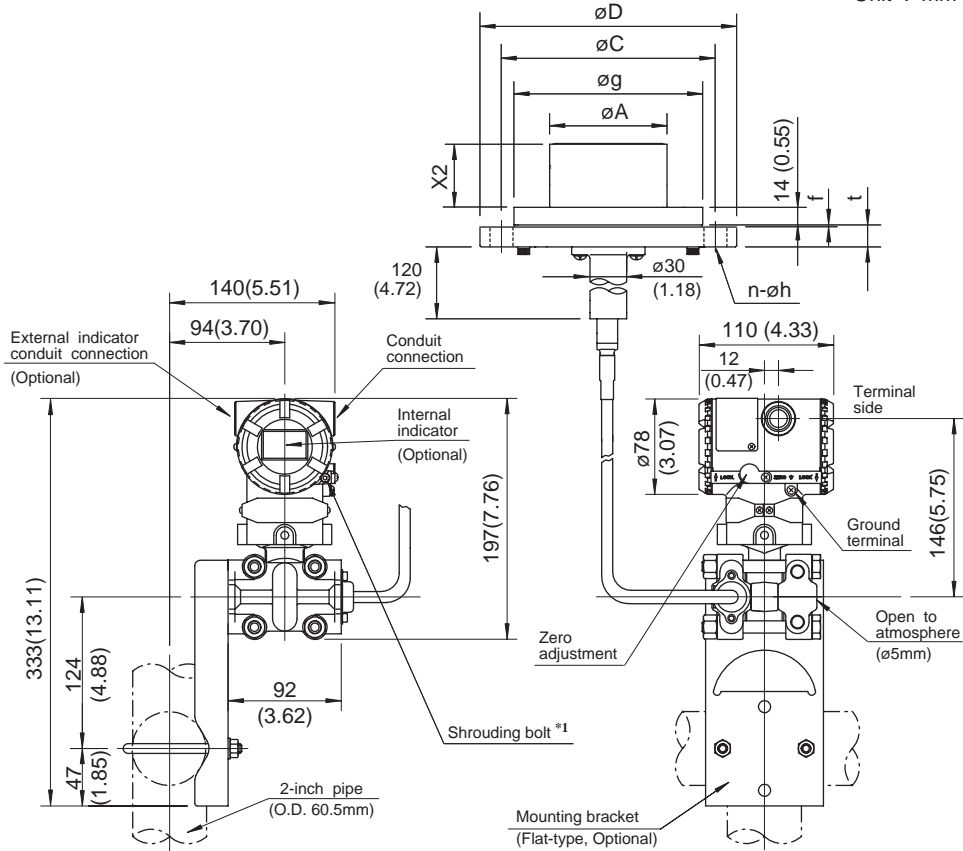

\*1: Applicable only for ATEX, IECEx, and TIS Flameproof type.

Diaphragm extension length code

- 2 : X<sub>2</sub> = 50 mm (2 inch)
- 4 : X<sub>2</sub> = 100 mm (4 inch)
- 6 : X<sub>2</sub> = 150 mm (6 inch)

**Process flange size : 4 inch (100 mm)**

Flange Rating	øD	øC	øg	øA	t	f*	n	øh
JIS 10K	210(8.72)	175(6.89)	155(6.10)	96±0.5(3.78)	18(0.71)	0	8	19(0.75)
JIS 20K	225(8.86)	185(7.28)	155(6.10)	96±0.5(3.78)	24(0.94)	0	8	23(0.91)
JIS 40K	250(9.84)	205(8.07)	155(6.10)	96±0.5(3.78)	36(1.42)	0	8	25(0.98)
ANSI Class 150	228.6(9.00)	190.5(7.50)	155(6.10)	96±0.5(3.78)	23.9(0.94)	1.6(0.06)	8	19.1(0.75)
ANSI Class 300	254(10.00)	200.2(7.88)	155(6.10)	96±0.5(3.78)	31.8(1.25)	1.6(0.06)	8	22.4(0.88)
JPI Class 150	229(9.02)	190.5(7.50)	155(6.10)	96±0.5(3.78)	24(0.94)	1.6(0.06)	8	19(0.75)
JPI Class 300	254(10.00)	200.2(7.88)	155(6.10)	96±0.5(3.78)	32(1.26)	1.6(0.06)	8	22(0.87)
DIN PN 10/16	220(8.66)	180(7.09)	155(6.10)	96±0.5(3.78)	20(0.79)	0	8	18(0.71)
DIN PN 25/40	235(9.25)	190(7.48)	155(6.10)	96±0.5(3.78)	24(0.94)	0	8	22(0.87)

**Process flange size : 3 inch (80 mm)**

Flange Rating	øD	øC	øg	øA	t	f*	n	øh
JIS 10K	185(7.28)	150(5.91)	130(5.12)	71±0.5(2.80)	18(0.71)	0	8	19(0.75)
JIS 20K	200(7.87)	160(6.30)	130(5.12)	71±0.5(2.80)	22(0.87)	0	8	23(0.91)
JIS 40K	210(8.27)	170(6.69)	130(5.12)	71±0.5(2.80)	32(1.26)	0	8	23(0.91)
ANSI Class 150	190.5(7.50)	152.4(6)	130(5.12)	71±0.5(2.80)	23.9(0.94)	1.6(0.06)	4	19.1(0.75)
ANSI Class 300	209.6(8.25)	168.1(6.62)	130(5.12)	71±0.5(2.80)	28.5(1.12)	1.6(0.06)	8	22.4(0.88)
JPI Class 150	190(7.48)	152.4(6)	130(5.12)	71±0.5(2.80)	24(0.94)	1.6(0.06)	4	19(0.75)
JPI Class 300	210(8.27)	168.1(6.62)	130(5.12)	71±0.5(2.80)	28.5(1.12)	1.6(0.06)	8	22(0.87)
DIN PN 10/16	200(7.78)	160(6.30)	130(5.12)	71±0.5(2.80)	20(0.79)	0	8	18(0.71)
DIN PN 25/40	200(7.78)	160(6.30)	130(5.12)	71±0.5(2.80)	24(0.94)	0	8	18(0.71)

\* In case where process flange material is JIS S25C, value of f is 0.

F04E.EPS

● Terminal Configuration

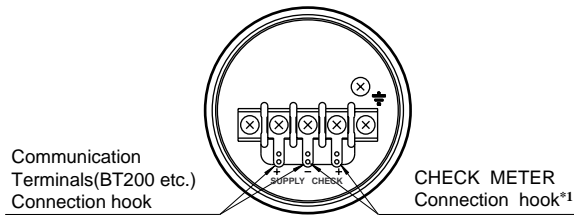

● Terminal Wiring

SUPPLY + -	Power supply and output terminal
CHECK + -	External indicator(ammeter) terminal*1
⏏	Ground terminal

\*1: When using an external indicator or a check meter, the internal resistance must be 10 Ω or less. Not available for Fieldbus communication(Output signal code F).

F05E.EPS

< Ordering Information > “◇”

Specify the following when ordering

1. Model, suffix codes, and optional codes
2. Calibration range and units:
  - 1) Calibration range can be specified with range value specifications up to 5 digits (excluding any decimal point) for low or high range limits within the range of -32000 to 32000.
  - 2) Specify only one unit from the table 'Settings when shipped.'
3. Select normal or reverse for operation mode
 

Note: If not specified, the instrument is shipped in normal operation mode.
4. Display scale and units (for transmitters equipped with integral indicator only)
 

Specify either 0 to 100 % or engineering unit scale and 'Range and Unit' for engineering units scale :  
Scale range can be specified with range limit specifications up to 5 digits (excluding any decimal point) for low or high range limits within the range of -19999 to 19999.
5. Tag Number (if required)
6. Process fluid temperature for zero compensation (if required)

< Related Instruments > “◇”

Power Distributor: Refer to GS 01B04T01-02E or GS 01B04T02-02E  
BRAIN TERMINAL: Refer to GS 01C00A11-00E

< Safety Barrier for TIIS Intrinsically Safe Type >

Supplier	Type	Model
MTL	Isolator	MTL3046B
		MTL4041B
P+F	Isolator	KFD2-STC3-Ex 1
		KFD2-STV3-Ex 1-1, 2, 3

T001E.EPS

Note: Requirements of capacitance and inductance for cable wiring.

$C_w \leq C_o - 11$ [nF]  
 $L_w \leq L_o - 730$ [μH]  
(C<sub>o</sub>: Max. external capacitance)  
(L<sub>o</sub>: Max. external inductance)

< Reference >

1. JIS SUS316L stainless steel; Equivalent to AISI 316L.
2. JIS SUS316 stainless steel; Equivalent to AISI 316.
3. JIS SUS304 stainless steel; Equivalent to AISI 304.
4. JIS S25C carbon steel; Equivalent to AISI 1025.
5. JIS SECC; Carbon steel.
6. Teflon; Trademark of E.I. duPont de Nemours & Co.
7. JIS SCM435 chrome molybdenum steel; Equivalent to AISI 4137.
8. JIS SUS630 stainless steel; Equivalent to ASTM 630.
9. Hastelloy; Trademark of Haynes International Inc.
10. JIS SCS14A stainless steel; Equivalent to JIS SUS316 cast stainless steel or ASTM CF-8M.
11. HART; Trademark of the HART Communication Foundation.
12. FOUNDATION; Trademark of Fieldbus Foundation.
13. Other company names and product names used in this material are registered trademarks or trademarks of their respective owners.