

General Specifications

GS 01E10A01-01E

Models SE100MJ/NJ and SE200MJ/NJ
Magnetic Flowmeter
Models SE14 Magnetic Flow Converter
Models SE100DJ/EJ, SE200DJ/EJ
and SE300DJ Magnetic Flow Tube



Solution to your profitability

ADMAG SE is the Safe and Easy magnetic flowmeter which makes your job simple and effective. You will increase the productivity and profitability. The installation, operation, and maintenance are all safe and easy.

ADMAG SE is equipped with a dual compartment housing providing ease of wiring while isolating the electronics from the environment. It is also prepared with HART or BRAIN communication as standard and its light weight makes installation easy.



FEATURES

- High Reliability
 - Based on Field Proven Technology
 - Proven Construction
 - Long Term Durability
- Compliance to World Market Requirements
 - General Safety
 - CE mark, C -Tick mark
 - Explosion Proof
 - ISO Standard
- High Accuracy (0.5% of flow rate)
- Easy Operation and Maintenance
 - Parameter Setting with Touch Control
 - Self Diagnostics
 - Light Weight and Easy Installation
 - Face to Face Length conform to ISO Standard (Flange Type)
- Easily Visible Display
 - The Large Visible LCD Panel
- Communication Capability
 - HART or BRAIN as standard
- Cost-effective

Note : HART is a registered trademark of the HART Communication Foundation .

STANDARD SPECIFICATIONS

Magnetic Flow Converter for SE100MJ/NJ, SE200MJ/NJ; SE14

- Note
- For models with no setting switches, a hand-held terminal is necessary to set parameters.
 - Pulse output, status output and alarm output use common terminals, therefore, these functions are not available at the same time.

Excitation method: Pulsed DC excitation

Output Signal

Current Output: 4 to 20 mA DC (Load resistance 600 ohm maximum.).

Transistor Contact Output(Open-collector):

Pulse, alarm or status output selected by parameter setting (Contact rating : 30V DC(OFF), 200mA*(ON))

* In case of FM-Nonincendive type, 135mA

Communication:

HART or BRAIN (Superimposed on the 4 to 20mA DC signal)

Conditions of Communication Line:

Load Resistance: (including cable resistance)

HART: 230 to 600 ohm, depending on q'ty of field devices connected to the loop (multidrop mode)

BRAIN: 250 to 600 ohm

Load Capacitance: 0.22 μF maximum

Load Inductance: 3.3 mH maximum

Distance from Power Line: 15 cm(0.6 ft) or more (Parallel wiring should be avoided.)

Input Impedance of Receiver Connected to the Receiving Resistance: 10k ohm or larger (at 2.4 kHz) (only for HART)

Maximum Cable Length: 2 km* (6500 ft) (when polyethylene-insulated PVC-sheathed control cables (CEV cables) are used)

* In case of FM-Nonincendive type, 1.5km(4875ft)

Instantaneous Flow Rate Display Function:

Flow rate can be displayed either in engineering units or in percent of span. (for models with indicator)

Totalizer Display Function:

Totalized volume in engineering units can be displayed by setting a totalizing factor. (for models with indicator)

Span Setting Function:

Volumetric flow setting is available by setting volume unit, time unit, flow rate value and flow tube size.

Volume Unit: m³, l, cm³, gallon(US), barrel(=158.987L)

Velocity Unit: m, ft

Time Unit: sec., min., hour, day

Flow Tube Size: mm, inch

Data Security During Power Failure:

Data storage in EEPROM - no back-up battery required.

Damping Time Constant:

Settable from 0.5 second to 200 seconds. (63% response time)

Pulse Output Function:

Scaled pulse can be output by setting a pulse factor.

Pulse Width:Duty 50% or fixed pulse width (0.5, 1, 20, 33, 50, or 100ms) - user selectable.

Output Rate : 0.0001 to 1000pps (when pulse output function is selected.)

Status Output Function:

One of the followings is selected by parameter setting.

- **Auto 2 Ranges Status Output :**
Indicates the selected range for automatic dual range function.
- **Forward and Reverse Status Output :**
Indicates the flow direction for forward and reverse flow measurement mode.
- **Totalization Status Output :**
Indicates that the internal totalized value exceeds the set value.
- **Low Limit Alarm :**
Indicates that flow rate under the low limit set value.

Alarm Output Function :

Indicates that an alarm occurs (Normal Close Fixed).

Self Diagnostics Function:

Converter failure, flow tube failure, erroneous setting, etc. can be diagnosed and displayed (for models with indicator).

Touch Control:

Parameter setting operation by infrared switches. (for models with indicator and setting switches)

Electrical Connection:

ANSI 1/2NPT female, DIN Pg13.5 female, ISO M20 X 1.5 female, JIS G1/2 female

Terminal Connection: M4 size screw terminal

Case Material: Aluminum alloy

Coating: Polyurethane corrosion-resistant coating
Deep sea moss green (Munsell 0.6GY3.1/2.0)

Protection: IP67, NEMA 4X, JIS C0920 water tight type

Mounting(SE14): 2-inch pipe mounting

■ **Magnetic Flow Tube for SE100MJ/NJ, SE200MJ/NJ; SE100DJ/EJ,SE200DJ/EJ and 300DJ**

Protection : IP67, NEMA 4X, JIS C0920 water tight type

Size in mm (in.):

15 (0.5), 25 (1), 40 (1.5), 50 (2), 80 (3), 100 (4), 150 (6), 200 (8), 250 (10)*, 300 (12)*, 350 (14)*, 400 (16)*
*Remote type only

Coating:

Terminal Box(SE***DJ/EJ):
Polyurethane corrosion-resistant coating,
Deep sea moss green (Munsell 0.6Y3.1/2.0)
• Terminal box is coated for all type

Body:

Polyurethane corrosion-resistant coating,
Deep sea moss green (Munsell 0.6Y3.1/2.0)

- All sizes of carbon steel flange type
- 150 and 200 mm of wafer type

No coating

- 15 to 100mm of stainless steel flange type
- 15 to 100mm of wafer type

Flow Tube Material:

Size 15 to 100mm (0.5 to 4in.)

Housing: Stainless steel (15mm:SCS11, 25 to100mm :SUS304)

Mini-flange for wafer conn.: Stainless steel(SUS430)

Flange : Carbon steel (SS400) or stainless steel (SUS304)

Pipe : Stainless steel (15 to 25mm:SCS13, 40 to 100mm: SUS304)

Terminal box(SE***DJ/EJ): Aluminum alloy

Size 150 to 400mm (6 to 16in.)

Housing: Carbon steel (SS400)

Mini-flange for wafer conn.: Carbon steel (SS400)

Flange : Carbon steel (SS400) or stainless steel (SUS304)

Pipe : Stainless steel (SUS304)

Terminal box(SE***DJ/EJ):Aluminum alloy

Wetted Part Material :

Lining : Fluorocarbon PFA

Electrode : Stainless steel (SUS316L), Hastelloy C (equivalent to Hastelloy C-276)
Titanium, Tantalum, Platinum-Iridium, Tungsten Carbide.

Earth Ring : • Size 15 to 200mm

- Stainless steel (SUS316), Hastelloy C (equivalent to Hastelloy C-276), Titanium, PFA lining + Earth electrode(Tantalum/Platinum-iridium)
- Size 250, 300mm Stainless steel (SUS316), Hastelloy C (equivalent to Hastelloy C-276), Titanium
- Size 350, 400mm Stainless steel (SUS316)

Note : Hastelloy is a registered trademark of Haynes International Inc.

Gasket:

- VALQUA#4010 ; Fluoro rubber, viton (between flow tube body and earth ring; for optional code/FRG)

- Non-asbestos joint sheet sheathed with fluoro resin PTFE (between earth ring and process flange; for optional code or /BSF)

Other gaskets between flow tube and earth ring;

- VALQUA#4010(Mixing#RCD970) ; Alkari resistance gasket for PVC piping(Fluoro rubber)
- VALQUA#4010(Mixing#RCD470) ; Acid resistance gasket for PVC piping(Fluoro rubber)

Contact YOKOGAWA office.(Refer to TI 1E6A0-06E)

Electrode Construction: External insertion type**Electrical Connection(SE***DJ/EJ):**

ANSI 1/2NPT female, DIN Pg13.5 female, ISO M20 X 1.5 female, JIS G1/2 female

Grounding: 100Ω or less

*In case of explosion proof type, the protective grounding must be connected to a suitable IS grounding system.

HAZARDOUS AREA CLASSIFICATION

CENELEC ATEX(KEMA):

SE100NJ and SE200NJ

No. KEMA 98ATEX3230
 EEx dm[ia] II C T6..T3 ; Group II Category 2 G
 Electrode Circuit Um ; 250Vac/dc
 Excitation Circuit ; 41V max. 6/6.25Hz
 Temp. Class ; T6 T5 T4 T3
 Process Temp. ; 70 85 120 130°C
 Enclosure ; IP67

SE14

No. KEMA 98ATEX3230
 EEx d II C T6 ; Group II Category 2 G
 Electrode Circuit Um ; 250Vac/dc
 Excitation Circuit ; 41V max. 6/6.25Hz
 Enclosure ; IP67

SE100EJ and SE200EJ

No. KEMA 98ATEX3230
 EEx dm[ia] II C T6..T3 ; Group II Category 2 G
 Electrode Circuit Um ; 250Vac/dc
 Excitation Circuit ; 41V max. 6/6.25Hz
 Temp. Class ; T6 T5 T4 T3
 Process Temp. ; 70 85 120 150°C
 Enclosure ; IP67

FM:

SE100NJ and SE200NJ

Explosion proof for Class I, Division 1, Groups A, B, C & D.
 Dust-ignition proof for Class II/III, Division 1, Groups E, F & G.
 Leads factory sealed.
 Intrinsically safe (electrodes) for Class I, Division 1, Groups A, B, C & D.
 Electrode circuit Vmax : 250 Vac/dc
 Temp. Code : T6 T5 T4 T3
 Max. Process Temp.: +70 +85 +120 +130°C
 Enclosure ; NEMA 4X

Note; • Installation shall be in accordance with the manufacturer's instructions and National Electric code, ANSI/NFPA-70.
 • There is no need of the conduit seal for both of Division 1 and 2 hazardous locations because this product is sealed at factory.

SE14

- Explosion proof for Class I, Division 1, Groups A, B, C & D.
 Dust-ignition proof for Class II/III, Division 1, Groups E, F & G.
 Temp. Code ; T6
 Enclosure ; NEMA 4X
- Nonincendive for Class I, Division 2, Groups A, B, C & D.
 Suitable for ClassII, Division 2, Groups F& G;
 Class III, Division 1 and 2.
 Temp. Code ; T4
 Enclosure ; NEMA 4X

• Nonincendive Field Wiring Parameter

Output signal	Signal name	Voc (V)	Isc (mA)	Ca (μF)	La (mH)
Analog output	Current output	19.7	21.6	0.3	10

The nonincendive field wiring concept allows interconnection of two FM Approved Nonincendive Apparatuses with nonincendive field wiring parameters not specifically examined in combination as a system when:
 $Voc \leq Vmax$, $Isc \leq Imax$, $Ca \geq Ci + Ccable$, $La \geq Li + Lcable$

T00-1.EPS

Input signal	Signal name	Vmax (V)	Imax (mA)	Ci (μF)	Li (mH)
Contact output	Transistor output	30	135	0.1	0

The nonincendive field wiring concept allows interconnection of two FM Approved Nonincendive Apparatuses with nonincendive field wiring parameters not specifically examined in combination as a system when:
 Voc or $Vt \leq Vmax$, Isc or $It \leq Imax$,
 $Ca \geq Ci + Ccable$, $La \geq Li + Lcable$

T00-2.EPS

Note; Installation shall be in accordance with the manufacturer's instructions and National Electric code, ANSI/NFPA-70.

SE100EJ and SE200EJ

Explosion proof for Class I, Division 1, Groups A, B, C & D.
 Dust-ignition proof for Class II/III, Division 1, Groups E, F & G.
 Leads factory sealed.
 Intrinsically safe (electrodes) for Class I, Division 1, Groups A, B, C & D.
 Electrode circuit Vmax = 250 Vac/dc
 Temp. Code : T6 T5 T4 T3
 Max. Process Temp.: +70 +85 +120 +150°C
 Enclosure ; NEMA 4X

Note; • Installation shall be in accordance with the manufacturer's instructions and National Electric code, ANSI/NFPA-70.
 • There is no need of the conduit seal for both of Division 1 and 2 hazardous locations because this product is sealed at factory.

CSA:

SE100NJ and SE200NJ

Class I, Groups B, C & D; Class II, Groups E, F & G; Class III; Encl Type 4X
 Electrodes: Intrinsically Safe, Ex ia, Class I, Groups A, B, C & D
 When installed in Class I, Division 2 locations - Seals No Required.
 Electrode Circuit Vmax : 250 Vac/dc
 Excitation Circuit : 41V max. 6/6.25Hz

Temperature Code	Maximum Ambient Temperature	Maximum Process Temperature	Minimum Process Temperature
T6	+60°C	+70°C	-40°C
T5	+60°C	+85°C	-40°C
T4	+60°C	+120°C	-40°C
T3	+60°C	+130°C	-40°C

Ambient Temperature : -20 to +60°C
 Maximum Working Pressure :
 4MPa (SE115N to SE205N)
 2MPa (SE208N to SE220N)
 Flange rating should be also considered.

SE14

Class I, Groups B, C & D; Class II, Groups E, F & G; Class III; Encl Type 4X
 When installed in Class I, Division 2 locations - Seals No Required.
 Excitation Circuit : 41V max. 6/6.25Hz
 Temp. Code : T6
 Ambient Temperature : -20 to +60°C
SE100EJ and SE200EJ
 Class I, Groups B, C & D; Class II, Groups E, F & G; Class III; Encl Type 4X
 Electrodes: Intrinsically Safe, Ex ia, Class I, Groups A, B, C & D
 When installed in Class I, Division 2 locations - Seals No Required.

Excitation Circuit : 41V max. 6/6.25Hz
 Electrode Circuit Vmax : 250 Vac/dc

Temperature Code	Maximum Ambient Temperature	Maximum Process Temperature	Minimum Process Temperature
T6	+60°C	+70°C	-40°C
T5	+60°C	+85°C	-40°C
T4	+60°C	+120°C	-40°C
T3	+60°C	+150°C	-40°C

Ambient Temperature : -20 to +60°C
 Maximum Working Pressure :

4MPa (SE115N to SE205N)
 2MPa (SE208N to SE220N)
 Flange rating should be also considered.

Note: There is no need of the conduit seal for Division 2 hazardous location because these products are sealed at factory.

SAA:

SE100NJ and SE200NJ

SA Certificate No. AUS Ex 3764X
 Ex d m ia II C T6..T3
 Enclosure : IP67
 Excitation Circuit ; 41V max. 6/6.25Hz
 Electrode Circuit Um : 250Vac/dc

Temperature Code	Maximum Ambient Temperature	Maximum Process Temperature	Minimum Process Temperature
T6	+60°C	+70°C	-40°C
T5	+60°C	+85°C	-40°C
T4	+60°C	+120°C	-40°C
T3	+60°C	+130°C	-40°C

SE14

SA Certificate No. AUS Ex 3764X
 Ex d II C T6
 Enclosure : IP67
 Excitation Circuit : 41V max. 6/6.25Hz

SE100EJ and SE200EJ

SA Certificate No. AUS Ex 3764X
 Ex d m ia II C T6..T3
 Enclosure : IP67
 Excitation Circuit : 41V max. 6/6.25Hz
 Electrode Circuit Um : 250Vac/dc

Temperature Code	Maximum Ambient Temperature	Maximum Process Temperature	Minimum Process Temperature
T6	+60°C	+70°C	-40°C
T5	+60°C	+85°C	-40°C
T4	+60°C	+120°C	-40°C
T3	+60°C	+150°C	-40°C

STANDARD PERFORMANCE

SE***MJ/NJ, SE***DJ/EJ+SE14(Up to 300m cable length)

Accuracy :

Size in mm (inch)	Span in m/s (ft/s)	Accuracy
15 to 400 (0.5 to 16)	0.3 to 1 (1 to 3)	0.5% of span
	1 to 10 (3 to 33)	0.25% of span (at indications below 50% of span)
		0.5% of rate (at indications 50% of span or more)

Repeatability: 0.1% of flowrate(1mm/s minimum)^{T01.EPS}

Maximum Power Consumption:

10W for SE***MJ/NJ
 11W for SE***DJ/EJ+SE14

Insulation Resistance:

- SE***MJ/NJ
- 100MΩ between power terminals and ground terminal at 500V DC.
 - 100MΩ between power terminals and each output terminal at 500V DC.

- 20MΩ between each output terminal and ground terminal at 100V DC.

SE14

- 100MΩ between power terminals and ground terminal at 500V DC.
- 100MΩ between power terminals and each output terminal at 500V DC.
- 20MΩ between each output terminal (except for EX1 and EX2) and ground terminal at 100V DC.
- 20MΩ between (EX1 or EX2) and ground terminal at 50V DC.

SE*DJ/EJ**

- 100MW between excitation terminal(EX1) and signal terminals(A, B and C) at 500V DC.
- 100MW between common terminal(C) and signal terminals(A and B) at 500V DC.
- 100MW between signal terminal (A) and signal terminal(B) at 500V DC.

Withstand Voltage:

SE*MJ/NJ; SE14**

- 1500V AC between power terminals and ground terminal for 1 minute. (for -A1/A2 power supply)
- 500V AC between power terminals and ground terminal for 1 minute. (for -D1 power supply)

SE*DJ/NJ**

- 1000V AC between excitation terminals (EX1 and EX2) and ground terminal(G) for 1 minute.
- 500V AC between signal terminals(A and B) and ground terminal(G) for 1 minute.(for /KF2, /FF1)
- 2000V AC between signal terminals(A and B) and excitation terminals(EX1 and EX2) for 1 minute. (for /KF2, /FF1)

Safety Requirement Standard:

IEC1010, EN61010

EMC Conformity Standard:

EN61326
 EN61000-3-2, EN61000-3-3
 AS/NZS 2064

Pressure Equipment Directive:

Notified Body Identification Number 0038
 Module : H

MODEL	DN(mm)*	PS(MPa)*	PS-DN(MPa-mm)	CATEGORY**
SE115	15	4	60	Article 3, *** paragraph 3
SE202	25	4	100	Article 3, *** paragraph 3
SE204	40	4	160	II
SE205	50	4	200	II
SE208	80	2	160	II
SE210	100	2	200	II
SE215	150	2	300	II
SE220	200	2	400	III
SE325	250	2	500	III
SE330	300	2	600	III
SE335	350	1	350	II
SE340	400	1	400	III

* PS: Maximum allowable pressure for Flow Tube, DN: Noinal size

** Referred to Table 6 covered by ANNEX II of EC Directive on Pressure Equipment Directive 97/23/EC.

***SE115 and SE202 are not attached CE mark of PED because they do not come under CE marking of PED.

NORMAL OPERATING CONDITION

Ambient Temperature: -20 to 60 °C (-4 to 140 °F)

Note : The minimum temperature is -10°C (14°F) in case of the 40mm or larger sizes with the carbon steel flange connection or wafer connection.

Ambient Humidity: 5 to 95%RH (no condensation)

Rated Power Supply Voltage:

100V AC/DC Version:

Range 80 to 127V AC, 47 to 63Hz
90 to 110V DC

230V AC Version

Range 180 to 264V AC

24V DC/AC Version :

Range 20.4 to 28.8 V DC/AC

Supplied Power and Max. Cable Length for 24V DC version:

Allowable cable length m(ft)

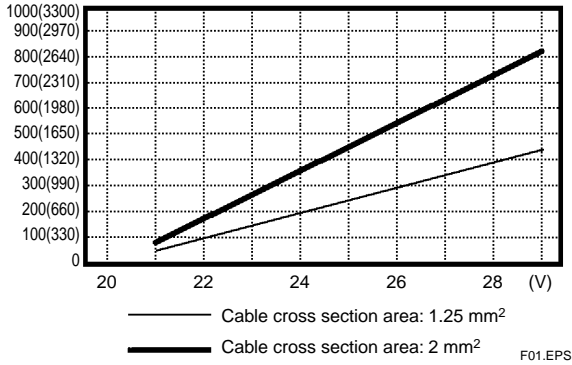

Altitude at installation side: Max.2000m above sea level

Installation category based on IEC1010: II(See Note)

Pollution level based on IEC1010: 2(See Note)

Note: • The "Installation category" implies the regulation for impulse withstand voltage. It is also called the "Overvoltage category". "II" applies to electrical equipment.

• "Pollution level" describes the degree to which a solid, liquid or gas which deteriorates dielectric strength is adhering. "2" applies to a normal indoor atmosphere.

Fuse: 2A 250V (Time-Lag type)

Fluid Conductivity: 5µS/cm or larger

*In case that size 250 or 300mm is used for high conductivity fluid (ex. caustic soda, seawater), please use the flange type.

Measurable Flow Rate Range:

SI Units (Size : mm, Flowrate : m³/h) English Units (Size : inch, Flowrate : GPM)

Size	MIN. Range @ 0.3m/s	MAX. Range @ 10m/s	Size	MIN. Range @ 1.0ft/s	MAX. Range @ 33ft/s
15	0.1909	6.361	0.5	0.6024	20.078
25	0.5302	17.671	1	2.4095	80.31
40	1.3572	45.23	1.5	5.422	180.70
50	2.1206	70.68	2	9.638	321.2
80	5.429	180.95	3	21.685	722.8
100	8.483	282.74	4	38.56	1,285.0
150	19.086	636.1	6	86.74	2,891.3
200	33.93	1,130.9	8	154.21	5140
250	53.02	1,767.1	10	240.95	8031
300	76.35	2,544.6	12	347.0	11,565
350	103.91	3,463	14	472.3	15,741
400	135.72	4,523	16	616.9	20,560

T02.EPS

Fluid Temperature and Pressure:

Integral type SE***MJ/NJ

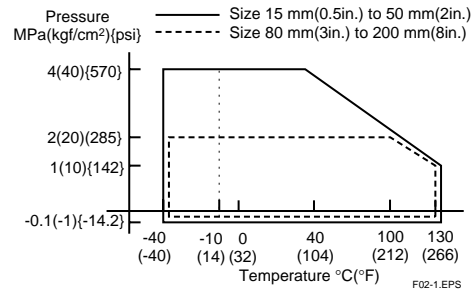

F02-1.EPS

Remote type SE***DJ/EJ

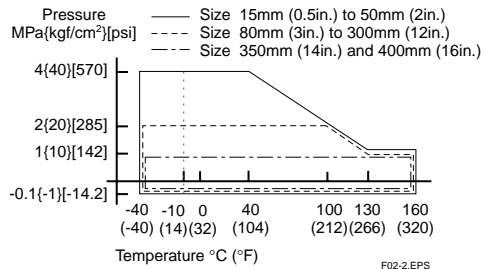

F02-2.EPS

Note 1: The above limits show maximum allowable fluid pressure for Flow Tube itself. Further fluid pressure should also be limited according to flange rating.

Note 2: The minimum temperature is -10°C (14°F) in case of the 40mm or larger sizes with the carbon steel flange connection or wafer connection.

TERMINAL CONNECTION

Integral type flowmeter(SE***MJ/NJ):

Terminal Symbols	Description
G POWER N- POWER L+	Ground and power supply
CUR+ CUR-	
PLS/ALM+ PLS/ALM-	Current output 4 to 20 mA DC
⊕	Pulse, alarm or status output
⊕	Protective grounding

T03-3.EPS

Remote type converter(SE14):

Terminal Symbols	Description
SA	A shield
A	
B	
SB	Flow signal input
C	
EX1	Excitation current output
EX2	
PLS/ALM OUT	Pulse, alarm or status output
CUR OUT	Current output 4 to 20mA DC
L/+ N/- G	Power supply and Ground
⊕	
⊕	Protective grounding

T03-1.EPS

Remote type flow tube(SE***DJ/EJ):

Terminal Symbols	Description
A	Flow signal output
B	
C	
EX1	Excitation current input
EX2	
⊕	Function grounding (Outside of the Terminal box)

T03-2.EPS

MODEL AND SUFFIX CODE

Integral Type Magnetic Flowmeter:

Model	Suffix Code	Description
SE115	Nominal Size 15 mm (1/2in.)
SE202	Nominal Size 25 mm (1in.)
SE204	Nominal Size 40 mm (1 1/2in.)
SE205	Nominal Size 50 mm (2in.)
SE208	Nominal Size 80 mm (3in.)
SE210	Nominal Size 100 mm (4in.)
SE215	Nominal Size 150 mm (6in.)
SE220	Nominal Size 200 mm (8in.)
Construction	M	Integral type for General Purpose
	N	Integral type for Explosion Proof
Aux. Code	J	Always J
Output Signal	-D	4-20 mA and Pulse or Alarm, Simultaneous 2-output (BRAIN)
	-E	4-20 mA and Pulse or Alarm, Simultaneous 2-output (HART)
Lining	A	Fluorocarbon PFA
Process Connection	B1S	ANSI 150 Wafer
	B2S	ANSI 300 Wafer
	E1S	DIN PN10 Wafer Only for 200 mm (Note 1)
	E2S	DIN PN16 Wafer Only for 80 to 200 mm (Note 1)
	E4S	DIN PN40 Wafer Only for 15 to 50 mm (Note 1)
	K1S	JIS 10K Wafer
	K2S	JIS 20K Wafer
	A1C	ANSI 150 Flange Carbon Steel (SS400)
	A2C	ANSI 300 Flange Carbon Steel (SS400)
	D1C	DIN PN10 Flange Carbon Steel (SS400), Only for 200 mm (Note 1)
	D2C	DIN PN16 Flange Carbon Steel (SS400), Only for 80 to 200 mm (Note 1)
	D4C	DIN PN40 Flange Carbon Steel (SS400), Only for 15 to 50 mm (Note 1)
	J1C	JIS 10K Flange Carbon Steel (SS400)
	J2C	JIS 20K Flange Carbon Steel (SS400)
	G1C	JIS F12 Flange Carbon Steel (SS400), Only for 80 to 200 mm
	A1S	ANSI 150 Flange Stainless Steel (SUS304)
	A2S	ANSI 300 Flange Stainless Steel (SUS304)
	D1S	DIN PN10 Flange Stainless Steel (SUS304), Only for 200 mm (Note 1)
	D2S	DIN PN16 Flange Stainless Steel (SUS304), Only for 80 to 200 mm (Note 1)
	D4S	DIN PN40 Flange Stainless Steel (SUS304), Only for 15 to 50 mm (Note 1)
J1S	JIS 10K Flange Stainless Steel (SUS304)	
J2S	JIS 20K Flange Stainless Steel (SUS304)	
G1S	JIS F12 Flange Stainless Steel (SUS304), Only for 80 to 200 mm	
Electrode Material	-L	Stainless Steel (SUS316L)
	-P	Platinum-iridium
	-H	Hastelloy C276 Equivalent
	-T	Tantalum
	-V	Titanium
	-W	Tungsten Carbide
Earth ring and Earth electrode Material	N	Non Earth Ring
	S	Stainless Steel (SUS316)
	P	Platinum-iridium Electrode
	H	Hastelloy C276 Equivalent
	T	Tantalum Electrode
	V	Titanium
Electrical Connection (Refer to Note2)	0	JIS G1/2 Female
	2	ANSI 1/2NPT Female
	3	DIN Pg13.5 Female
	4	ISO M20X1.5 Female
Power Supply	-A1	80 to 127 V AC/90 to 110 V DC
	-A2	180 to 264 V AC
	-D1	20.4 to 28.8 V DC/AC
Indicator	NN ..	Non Indicator
	H1 ..	With Horizontal Indicator
	H2 ..	With Horizontal Indicator and Setting SW
	V1 ..	With Vertical Indicator
	V2 ..	With Vertical Indicator and Setting SW
Optional Code	/□	

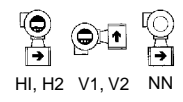

Note 1: Select PN40 when PN10, PN16, PN25 is required for 15 to 50mm, and select PN16 when PN10 is required for 80 to 150mm, because of same mating dimensions.

Note 2: Only ANSI1/2NPT electrical connection is available for FM or CSA explosion proof type. JIS G1/2 electrical connection is not available for any explosion proof type.

T04.EPS

Magnetic Flow Converter:

Model	Suffix code	Description
SE14	Magnetic Flow Converter
Aux.Cod	-J.....	Always J
Output	D E	4-20mA and Pulse or Alarm, Simultaneous 2-output (BRAIN) 4-20mA and Pulse or Alarm, Simultaneous 2-output (HART)
Indicator	NN H1 H2	Non Indicator With Indicator With Indicator and Setting SW
Power Supply	-A1 -A2 -D1	80 to 127V AC / 90 to 110 VDC 180 to 264 V AC 20.4 to 28.8V DC/AC
Electrical Connection (Refer to Note1)	0 2 3 4	JIS G1/2 Female ANSI 1/2NPT Female DIN Pg 13.5 Female ISO M20X1.5 Female
Optional Codes	/□..	

Note1 : Only ANSI 1/2NPT electrical connection is available for FM or CSA explosion proof type.
JIS G1/2 electrical connection is not available for any explosion proof type.

Dedicated Signal Cable:

Model	Suffix Code	Description
AM011	Dedicated cable for magnetic flowmeter
End treatment	-0 -4	Non termination Terminated
Cable length	-L□□□.....	Enter the length in m (Max 300m)
Style code	*A	Style A
Optional specification	/C□..	Number of end treatment parts

Note 1 : A user provided two conductor cable is required for coil excitation.
Note 2 : The maximum temperature for the signal cable is 80°C(176°F).

T10.EPS

Magnetic Flow Tube SE100DJ/EJ and SE200DJ/EJ:

Model	Suffix code	Description
SE115	Nominal Size 15mm (1/2in.)
SE202	Nominal Size 25mm (1in.)
SE204	Nominal Size 40mm (1 1/2in.)
SE205	Nominal Size 50mm (2in.)
SE208	Nominal Size 80mm (3in.)
SE210	Nominal Size 100mm (4in.)
SE215	Nominal Size 150mm (6in.)
SE220	Nominal Size 200mm (8in.)
Construction	D E	Remote Type for General Purpose Remote Type for Explosion Proof
Aux. Code	J	Always J
Lining	-A	Fluorocarbon PFA
Process connection	B1S B2S E1S E2S E4S K1S K2S A1C A2C D1C D2C D4C J1C J2C G1C A1S A2S D1S D2S D4S J1S J2S G1S	ANSI 150 Wafer ANSI 300 Wafer DIN PN10 Wafer Only for 200mm DIN PN16 Wafer Only for 80 to 200mm DIN PN40 Wafer Only for 15 to 50mm JIS10K Wafer JIS20K Wafer ANSI 150 Flange Carbon Steel (SS400) ANSI 300 Flange Carbon Steel (SS400) DIN PN10 Flange Carbon Steel (SS400), Only for 200mm (Note 1) DIN PN16 Flange Carbon Steel (SS400), Only for 80 to 200mm (Note 1) DIN PN40 Flange Carbon Steel (SS400), Only for 15 to 50mm (Note 1) JIS 10K Flange Carbon Steel (SS400) JIS 20K Flange Carbon Steel (SS400) JIS F12 Flange Carbon Steel (SS400), Only for 80 to 200mm ANSI 150 Flange Stainless Steel (SUS304) ANSI 300 Flange Stainless Steel (SUS304) DIN PN10 Flange Stainless Steel (SUS304), Only for 200mm (Note 1) DIN PN16 Flange Stainless Steel (SUS304), Only for 80 to 200mm (Note 1) DIN PN40 Flange Stainless Steel (SUS304), Only for 15 to 50mm (Note 1) JIS 10K Flange Stainless Steel (SUS304) JIS 20K Flange Stainless Steel (SUS304) JIS F12 Flange Stainless Steel (SUS304), Only for 80 to 200mm
Electrode material	-L -P -H -T -V -W	Stainless Steel (SUS316L) Platinum-iridium Hastelloy C-276 Equivalent Tantalum Titanium Tungsten Carbide
Earth ring and earth electrode material	N S P H T V	Non Earth Ring Stainless Steel (SUS316) Platinum-iridium Electrode HastelloyC-276 Equivalent Tantalum Electrode Titanium
Electrical connection (Refer to Note2)	0 2 3 4	JIS G1/2 Female ANSI 1/2NPT Female DIN Pg13.5 Female ISO M20X1.5 Female
Optional code	/□	

Note 1 : Select PN40 when PN10, PN16, PN25 is required for 15 to 50mm, and select PN16 when PN10 is required for 80 to 150mm, because of same mating dimensions.

Note 2 : Only ANSI1/2NPT electrical connection is available for FM or CSA explosion proof type. JIS G1/2 electrical connection is not available for any explosion proof type.

T07.EPS

Magnetic Flow Tube : SE300DJ

Model	Suffix code	Description
SE325 SE330 SE335 SE340	Nominal Size 250mm (10in.) Nominal Size 300mm (12in.) Nominal Size 350mm (14in.) Nominal Size 400mm (16in.)
Construction	D	Remote Type for General Purpose
Aux. Code	J	Always J
Lining	-A	Fluorocarbon PFA
Process connection	B1C E1C K1C H1C J1C J2C A1C A2C D1C D2C G1C J1S J2S A1S A2S D1S D2S G1S	ANSI 150 Wafer Only for size 250 and 300mm (10 and12in.) DIN PN10 Wafer Only for size 250 and 300mm (10 and12in.) JIS 10K Wafer Only for size 250 and 300mm (10 and12in.) JIS F12 Wafer Only for size 250 and 300mm (10 and12in.) JIS 10K Flange Carbon Steel (SS400) JIS 20K Flange Carbon Steel (SS400), Only for size 250 and 300mm (10 and12in.) ANSI 150 Flange Carbon Steel (SS400) ANSI 300 Flange Carbon Steel (SS400), Only for size 250 and 300mm (10 and12in.) DIN PN10 Flange Carbon Steel (SS400) DIN PN16 Flange Carbon Steel (SS400), Only for size 250 and 300mm (10 and12in.) JIS F12 Flange Carbon Steel (SS400) JIS 10K Flange Stainless Steel (SUS304) JIS 20K Flange Stainless Steel (SUS304), Only for size 250 and 300mm (10 and12in.) ANSI 150 Flange Stainless Steel (SUS304) ANSI 300 Flange Stainless Steel (SUS304), Only for size 250 and 300mm (10 and12in.) DIN PN10 Flange Stainless Steel (SUS304) DIN PN16 Flange Stainless Steel (SUS304), Only for size 250 and 300mm (10 and12in.) JIS F12 Flange Stainless Steel (SUS304)
Electrode material	-L -P -H -T -V -W	Stainless Steel (SUS316L) Platinum-iridium Only for flange type Hastelloy C Equivalent Only for flange type Tantalum Only for flange type Titanium Only for flange type Tungsten Carbide
Earth ring material	N S H V	Non Earth Ring Stainless Steel (SUS316) Hastelloy C Equivalent Only for flange type Titanium Only for flange type
Electrical connection	0 2 3 4	JIS G1/2 Female ANSI 1/2NPT Female DIN Pg13.5 Female ISO M20X1.5 Female
Optional code	/□	

T08.EPS

Optional Specifications :

A: Available N: Not available

Item	Specification	Applicable Model						Code
		General			Ex-proof			
		SE***MJ	SE14	SE***DJ	SE***NJ	SE14	SE***EJ	
Waterproof Glands	Waterproof glands are attached to all wiring ports. For JIS G1/2 only.	A	A	A	N	N	N	/ECG
Waterproof Glands with Union Joints	Waterproof glands (union joints) are attached to all wiring ports. For JIS G1/2 only.	A	A	A	N	N	N	/ECU
Gaskets for PVC Pipe	Gaskets are attached between earth ring and flow tube. Only for size 15 to 200mm	A	N	A	A	N	A	/FRG
Bolt & Nut Assembly	Stainless steel bolts/nuts and non-asbestos PTFE-wrapped gaskets assembly for wafer type Available with 15 to 200mm(0.5 to 8in.)	A	N	A	A	N	A	/BSF
For District Heating and Cooling (For District Cooling)	Condensation proof for DHC use. Only for size 100 to 400mm Terminal box; urethane resin potting. Wired 30m signal cable at factory.	N	N	A	N	N	N	/DHC
DC Noise Suppression	Eliminating DC Noise (Size 15mm(0.5in.) or larger: Conductivity 50μS/cm or higher.)	N	A	N	N	A	N	/ELC
Burn Out Down	Current output at CPU failure is set to "Downward(2.4mA DC or less)". Without /C1 : Upward(21.6mA or more)	A	A	N	A	A	N	/C1
Lightning Protector	Built-in Lightning Protector	A	A	N	A	A	N	/A
Painting Color Change	Black, Munsell code : N1.5	A	A	A	A	A	A	/P1
	Jade Green, Munsell code : 7.5BG4/1.5	A	A	A	A	A	A	/P2
	Metallic Silver	A	A	A	A	A	A	/P7
Epoxy Coating	Coating is changed to epoxy coating.	A	A	A	A	A	A	/X1
High Anti-corrosion Coating	Coating is changed to three-layer coating. (Urethane coating on two-layer Epoxy coating)	A	A	A	A	A	A	/X2
Oil-prohibited Use	Degreased cleansing treatment	A	N	A	A	N	A	/K1
Oil-prohibited Use with Dehydrating Treatment	Degreased cleansing treatment and packed with desiccant	A	N	A	A	N	A	/K5
180 deg. Rotated Converter	180 deg. rotated converter for reversed flow direction	A	N	N	A	N	N	/CRC
Material Certificate	Reproduced material certificate for pipe, electrode, earth ring, mini-flange, and flange (depends on spec.).	A	N	A	A	N	A	/M01
Hydrostatics Test Certificate	With the following water pressure for 10min. The result is filled in Note column of our standard certificate. JIS10K, ANSI Class 150, DIN PN10 : 1.5MPa, JIS20K, ANSI Class 300, DIN PN16 : 3.0MPa, JIS F12 : 1.25MPa	A	N	A	A	N	A	/T01
Calibration Certificate	Level 2:Declaration and Calibration Equipment List	A	A	A	A	A	A	/L2
	Level 3:Declaration and Primary Standard List	A	A	A	A	A	A	/L3
	Level 4:Declaration and YOKOGAWA Measuring	A	A	A	A	A	A	/L4
CENELEC ATEX(KEMA)	Explosion Proof EExdm[ia]IICT6...T3;GroupII Category 2G	N	N	N	A	N	N	/KF2
Explosion Proof Type (Only for size 15 to 200mm)	Explosion Proof EExdIICT6;GroupII Category 2G	N	N	N	N	A	N	
	Explosion Proof EExdm[ia]IICT6...T3;GroupII Category 2G	N	N	N	N	N	A	
FM Explosion Proof Type (Only for size 15 to 200mm)	Explosion Proof	N	N	N	A	N	A	/FF1
	Explosion Proof/Nonincendive	N	N	N	N	A	N	/FF1/FN1
CSA Explosion Proof Type (Only for size 15 to 200mm)	Explosion proof	N	N	N	A	N	A	/CF1
SAA Explosion Proof Type (Only for size 15 to 200mm)	Explosion Proof Exdm[ia]IICT6...T3	N	N	N	A	N	N	/SF1
	Explosion Proof ExdIICT6	N	N	N	N	A	N	
	Explosion Proof Exdm[ia]IICT6...T3	N	N	N	N	N	A	
GOST Certification	Calibration Certificate for GOST (only for products produced at YMF)	A	A	A	A	A	A	/GOS

T09.EPS

EXTERNAL DIMENSION

15 mm (0.5 in) Wafer Type

Unit : mm(inch)

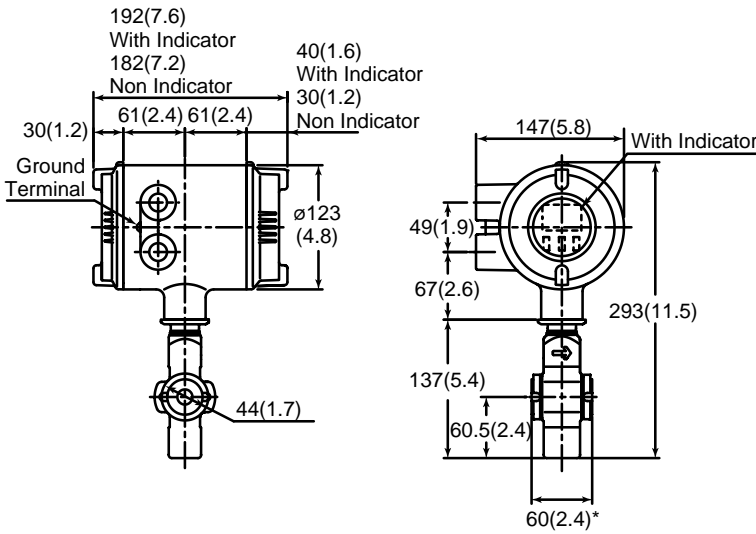

Lining : Fluorocarbon PFA
 Weight: 3.3kg(7.3 lb)
 With Indicator Option: Add 0.22kg(0.49lb)

* When no earth ring is selected the face to face length is shorter by approx. 1.6 mm(0.06 in).

The face to face length is longer by approx. 22 mm(0.87 in) for earth ring(P,T).

The face to face length is longer by approx. 8.4mm(0.33 in) for optional code /FRG.

25 mm (1 in) to 100 mm (4 in) Wafer Type

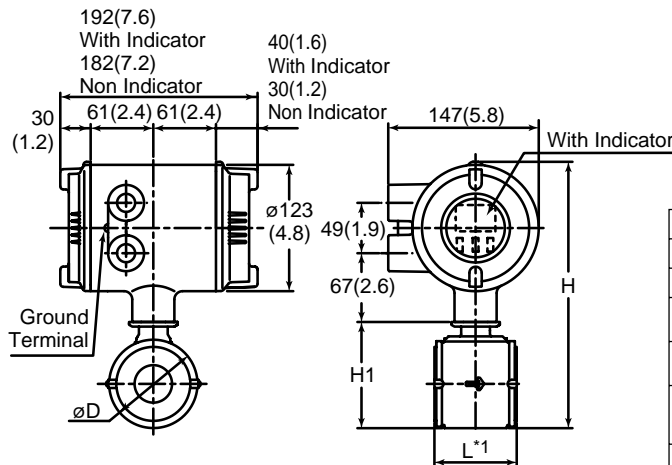

*1 When no earth ring is selected the face to face length is shorter by approx. 1.6 mm(0.06 in).

The face to face length is longer by approx. 22 mm (0.87 in) for earth ring(P,T).

The face to face length is longer by approx.8.4mm (0.33 in) for optional code/FRG.

Model	SE202□J	SE204□J	SE205□J	SE208□J	SE210□J
Nominal size	25(1)	40(1.5)	50(2)	80(3)	100(4)
Lining	Fluorocarbon PFA				
Face-to-face length	L*1	60(2.4)	70(2.8)	80(3.1)	120(4.7)
Outside diameter	∅D	67.5(2.7)	86(3.4)	99(3.9)	129(5.1)
Height	H	240(9.4)	260(10.2)	285(11.2)	307(12.1)
	H1	84(3.3)	104(4.1)	129(5.1)	156(6.1)
Weight kg(lb)*2	3.6(7.9)	3.8(8.3)	4.2(9.1)	6.6(14.6)	8.6(19.0)

*2 With Indicator Option: Add 0.22 kg(0.49 lb)

150 mm (6 in) to 200 mm (8 in) Wafer Type

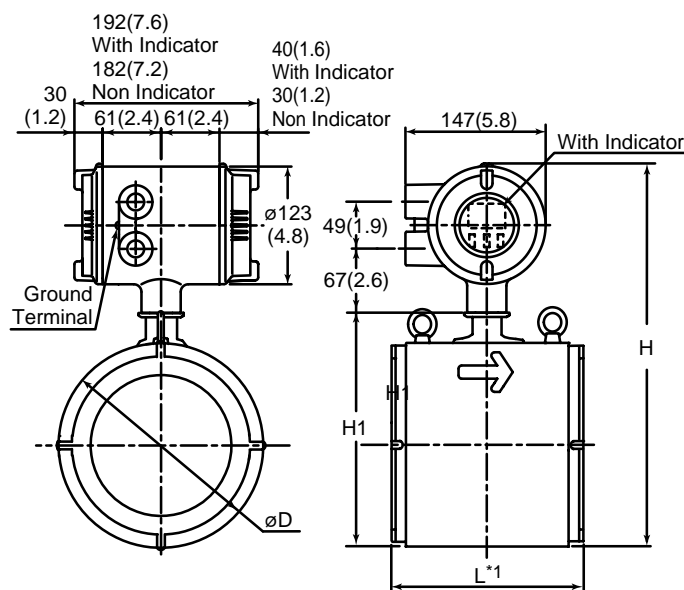

*1 When no earth ring is selected the face to face length is shorter by approx. 2 mm (0.08 in).

The face to face length is longer by approx. 32 mm (1.3 in) for earth ring(P,T).

The face to face length is longer by approx. 10.0mm (0.40in) for optional code/FRG.

Model	SE215□J	SE220□J
Nominal size	150(6)	200(8)
Lining	Fluorocarbon PFA	
Face-to-face length	L*1	200(7.9)
Outside diameter	∅D	218(8.6)
Height	H	407(16.0)
	H1	248(9.8)
Weight kg(lb)*2	16.1(35.5)	24.2(53.4)

*2 With Indicator Option: Add 0.22 kg(0.49 lb)

F03.EPS

15 mm (0.5 in) Flange Type

Unit : mm(inch)

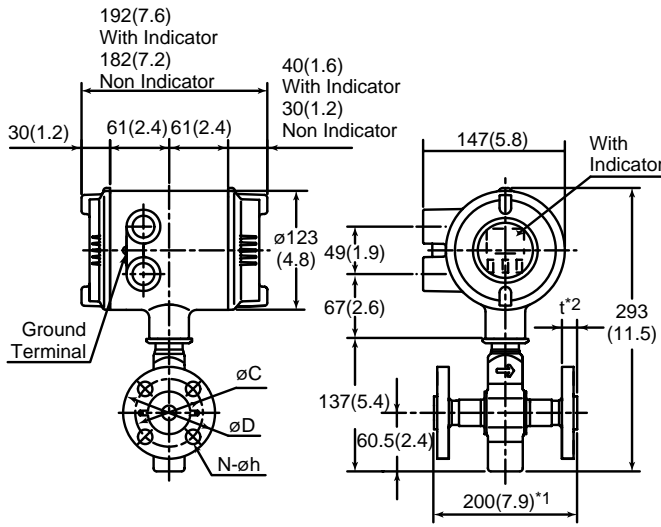

*1 When no earth ring is selected the face to face length is shorter by approx. 1.6 mm(0.06 in).

The face to face length is longer by approx. 22 mm (0.87 in) for earth ring(P,T).

The face to face length is longer by approx. 8.4 mm (0.33 in) for optional code/FRG.

*2 The thickness(t) is longer by approx. 11 mm (0.43 in) for earth ring(P,T).

The thickness(t) is longer by approx. 4.2 mm (0.17 in) for optional code/FRG.

Model	SE115□□					
Nominal size	15(0.5)					
Flange Type	J1□	J2□	A1□	A2□	D4□	
Lining	Fluorocarbon PFA					
Flange outside dia.	ϕD	95 (3.7)	95 (3.7)	88.9 (3.5)	95.3 (3.8)	95 (3.7)
Pitch circle dia.	ϕC	70 (2.8)	70 (2.8)	60.5 (2.4)	66.5 (2.6)	65 (2.6)
Number of holes	N	4				
Dia. of holes	ϕh	15 (0.6)	15 (0.6)	15.7 (0.6)	15.7 (0.6)	14 (0.6)
Thickness	t^*2	15.8 (0.6)	17.8 (0.7)	15 (0.6)	18 (0.7)	19.8 (0.8)
Weight kg(lb)*3		4.9 (10.7)	5.0 (11.1)	4.6 (10.0)	5.0 (11.0)	4.5 (9.9)

*3 With Indicator Option: Add 0.22 kg(0.49 lb)

25 mm (1 in) to 50 mm (2 in) Flange Type

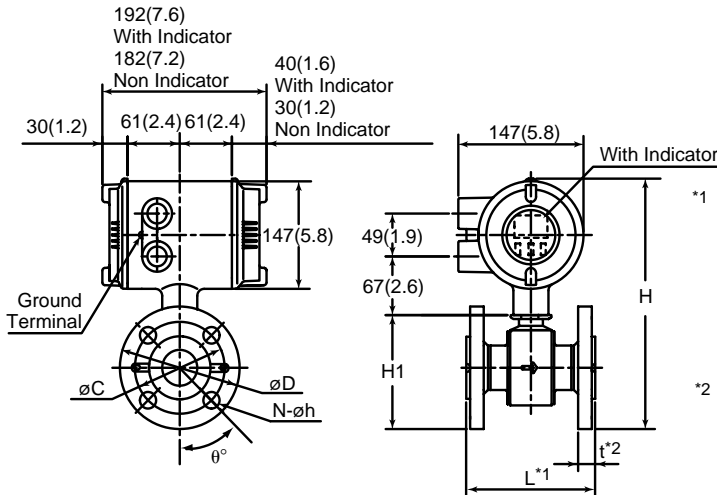

*1 When no earth ring is selected the face to face length is shorter by approx. 1.6 mm(0.06 in).

The face to face length is longer by approx. 22 mm (0.87 in) for earth ring(P,T).

The face to face length is longer by approx. 8.4 mm (0.33 in) for optional code/FRG.

*2 The thickness(t) is longer by approx. 11 mm (0.43 in) for earth ring(P,T).

The thickness(t) is longer by approx. 4.2 mm (0.17 in) for optional code/FRG.

Model	SE202□□					SE204□□					SE205□□					
Nominal size	25(1)					40(1.5)					50(2)					
Flange Type	J1□	J2□	A1□	A2□	D4□	J1□	J2□	A1□	A2□	D4□	J1□	J2□	A1□	A2□	D4□	
Lining	Fluorocarbon PFA					Fluorocarbon PFA					Fluorocarbon PFA					
Face to face length (ISO)	L^*1	200(7.9)										200(7.9)				
Flange outside dia.	ϕD	125 (4.9)	125 (4.9)	108 (4.3)	124 (4.9)	115 (4.5)	140 (5.5)	140 (5.5)	127 (5.0)	155.4 (6.1)	150 (5.9)	155 (6.1)	152.4 (6.0)	165.1 (6.5)	165 (6.5)	
Height	H	272 (10.7)	272 (10.7)	264 (10.4)	272 (10.7)	267 (10.5)	290 (11.4)	290 (11.4)	284 (11.1)	298 (11.7)	295 (11.6)	316 (12.4)	316 (12.4)	315 (12.4)	321 (12.6)	321 (12.6)
	H1	113 (4.4)	113 (4.4)	105 (4.1)	113 (4.4)	108 (4.3)	131 (5.2)	131 (5.2)	125 (4.9)	139 (5.5)	136 (5.4)	157 (6.2)	157 (6.2)	156 (6.1)	162 (6.4)	162 (6.4)
Pitch circle dia.	ϕC	90 (3.5)	90 (3.5)	79.2 (3.1)	88.9 (3.5)	85 (3.3)	105 (4.1)	105 (4.1)	105 (3.9)	98.6 (5.7)	144.3 (4.3)	110 (4.7)	120 (4.7)	120 (4.8)	120.7 (5.0)	127 (4.9)
Number of holes	N	4					4					4				
Dia. of holes	ϕh	19 (0.7)	19 (0.7)	15.7 (0.6)	19.1 (0.7)	14 (0.6)	19 (0.7)	19 (0.7)	15.7 (0.6)	22.4 (0.9)	18 (0.7)	19 (0.7)	19 (0.7)	19.1 (0.7)	19.1 (0.7)	18 (0.7)
Thickness	t^*2	17 (0.7)	19 (0.7)	17.2 (0.7)	20.7 (0.8)	21 (0.8)	19 (0.7)	21 (0.8)	20.5 (0.8)	23.5 (0.9)	21 (0.8)	19 (0.7)	21 (0.8)	22.2 (0.9)	25.2 (1.0)	23 (0.9)
Bolt hole pitch	θ°	45	45	45	45	45	45	45	45	45	45	45	22.5	45	22.5	45
Weight kg(lb)*3		6.0 (13.0)	6.3 (13.9)	5.3 (11.7)	6.5 (14.3)	6.3 (13.9)	7.6 (16.8)	7.9 (17.4)	7.2 (15.9)	9.5 (20.9)	9.2 (20.3)	9.0 (19.8)	9.1 (20.0)	9.5 (20.9)	11.1 (24.5)	10.9 (24.0)

*3 With Indicator Option: Add 0.22 kg(0.49 lb)

F04-1.EPS

Magnetic Flow Tube

Unit : mm (inch)

15mm (0.5in) Wafer Type

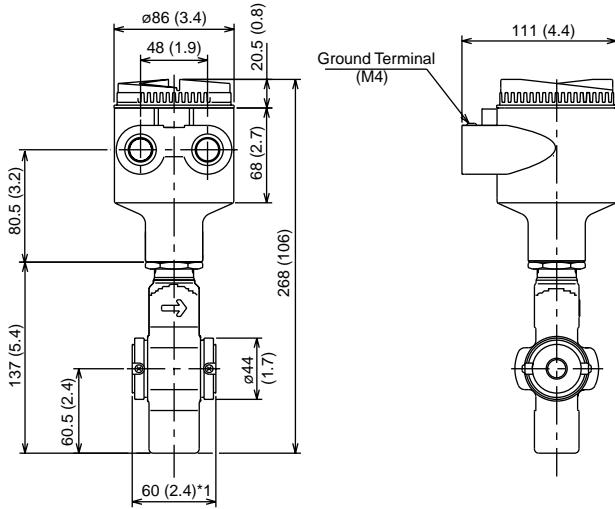

*1 When no earth ring is selected the face to face length is shorter by approx. 1.6mm (0.06in).

The face to face length is longer by approx. 22mm (0.87in) for earth ring (P,T).

The face to face length is longer by approx. 8.4mm(0.33in) for optional code /FRG.

Weight 1.9 kg (4.2 lb)

SD1d.eps

25mm (1in) to 100mm (4in) Wafer Type

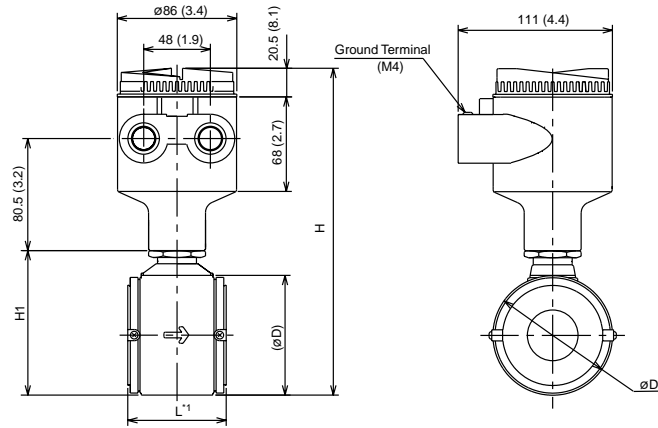

*1 When no earth ring is selected the face to face length is shorter by approx. 1.6mm (0.06in).

The face to face length is longer by approx. 22mm (0.87in) for earth ring (P,T).

The face to face length is longer by approx. 8.4mm(0.33in) for optional code /FRG.

Unit : mm (Approx. inch)

Model	SE202DJ SE202EJ	SE204DJ SE204EJ	SE205DJ SE205EJ	SE208DJ SE208EJ	SE210DJ SE210EJ
Nominal Size	25 (1)	40 (1.5)	50 (2)	80 (3)	100 (4)
Lining	Fluorocarbon PFA				
Face to face length	L*1 60 (2.4)	70 (2.8)	80 (3.1)	120 (4.7)	150 (5.9)
Outside diameter	øD 67.5 (2.7)	86 (3.4)	99 (3.9)	129 (5.1)	155 (6.1)
Height	H 215 (8.5)	235 (9.3)	260 (10.2)	282 (11.1)	313 (12.3)
	H1 84 (3.3)	104 (4.1)	129 (5.1)	151 (5.9)	182 (7.2)
Weight kg (lb)	1.9 (4.2)	2.5 (5.5)	2.9 (6.5)	5.1(11.3)	6.7(14.7)

SD2d.eps

150mm (6in), 200mm (8in) Wafer Type

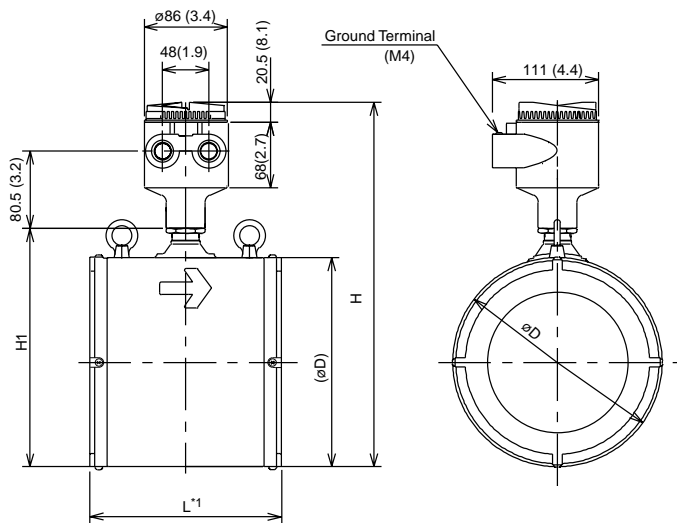

*1 When no earth ring is selected the face to face length is shorter by approx. 2mm (0.08in).

The face to face length is longer by approx. 32mm (1.3in) for earth ring (P,T).

The face to face length is longer by approx. 10.0mm(0.40in) for optional code /FRG.

Unit : mm (Approx. inch)

Model	SE215DJ SE215EJ	SE220DJ SE220EJ
Nominal Size	150 (6)	200 (8)
Lining	Fluorocarbon PFA	
Height	H 379 (14.9)	429 (16.9)
	H1 248 (9.8)	298 (11.7)
Outside diameter	øD 218 (8.6)	268 (10.6)
Face to face length	L*1 200 (7.9)	250 (9.8)
Weight	kg (lb) 14.5 (32.0)	22.5 (49.5)

SD3d.eps

250mm(10in), 300mm(12in) Wafer Type
Unit : mm (inch)

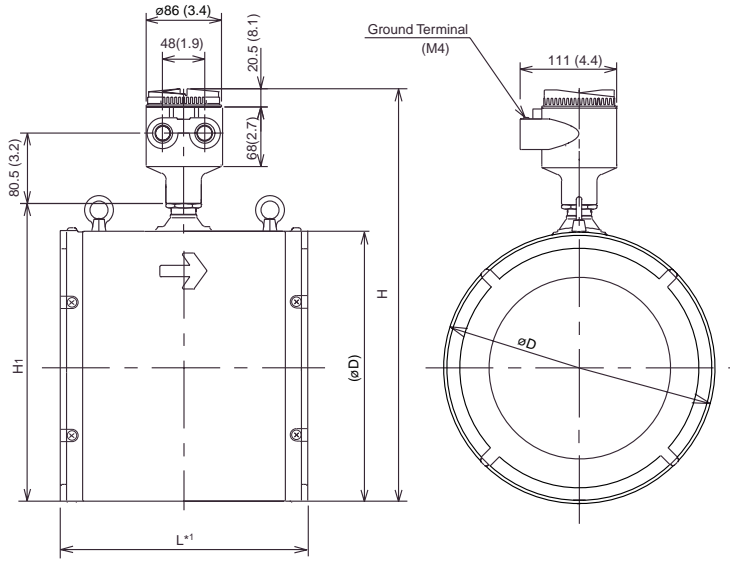

Unit : mm (Approx. inch)

Model	SE325DJ SE330DJ	
Nominal Size	250 (10)	300 (12)
Lining	Fluorocarbon PFA	
Height	H	471 (18.5) / 519 (20.4)
	H1	340 (13.4) / 388 (15.3)
Outside diameter	øD	310 (12.2) / 358 (14.1)
Face to face length	L*1	300 (11.8) / 350 (13.8)
Weight	kg (lb)	39 (86.0) / 48.3 (106.5)

*1 : When no earth ring is selected, the face to face length is shorter by approx. 2mm (0.08in).

SD3-2.eps

15mm (0.5in) Flange Type

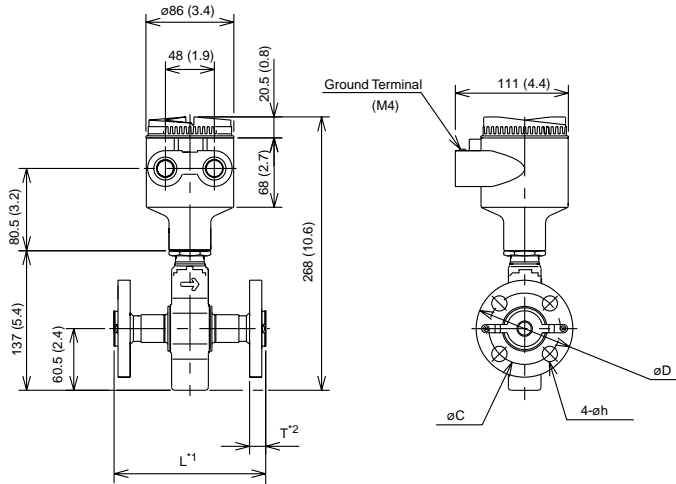

- *1 When no earth ring is selected the face to face length is shorter by approx. 1.6mm (0.06in). The face to face length is longer by approx. 22mm (0.87in) for earth ring(P,T). The face to face length is longer by approx. 8.4mm (0.33in) for optional code/FRG.
- *2 The thickness(T) is longer by approx. 4.2mm (0.17in) for optional code/FRG.

Unit : mm (Approx. inch)

Model	SE115DJ , SE115EJ				
Nominal size	15 (0.5)				
Flange Type	J1□	J2□	A1□	A2□	D4□
Lining	Fluorocarbon PFA				
Face to face length	L*1	200 (7.9)			
Flange outside dia	øD	95 (3.7)	95 (3.7)	88.9 (3.5)	95.3 (3.8)
Thickness (Except P,T Earthing)	T*2	15.8 (0.6)	17.8 (0.7)	15 (0.6)	18 (0.7)
Thickness (P,T Earthing)	T*2	26.8 (1.1)	28.8 (1.1)	26 (1.0)	29 (1.1)
Pitch circle dia.	øC	70 (2.8)	70 (2.8)	60.5 (2.4)	66.5 (2.6)
Dia. of holes	øh	15 (0.6)	15 (0.6)	15.7 (0.6)	15.7 (0.6)
Weight	kg (lb)	3.5 (7.7)	3.6 (8.0)	3.2 (7.1)	3.6 (8.0)

SD4d.eps

25mm (1in) to 50mm (2in) Flange Type

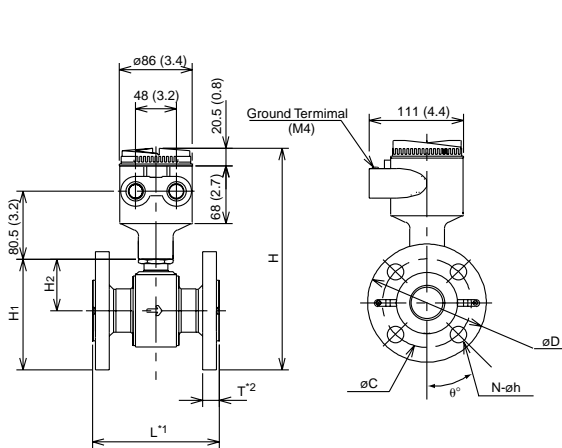

Unit : mm (Approx. inch)

Model	SE202DJ,SE202EJ				SE204DJ,SE204EJ				SE205DJ,SE205EJ						
Nominal Size	25 (1)				40 (1.5)				50 (2)						
Flange Type	J1□	J2□	A1□	A2□	D4□	J1□	J2□	A1□	A2□	D4□	J1□	J2□	A1□	A2□	D4□
Lining	Fluorocarbon PFA				Fluorocarbon PFA				Fluorocarbon PFA						
Height	H	244 (9.6)	236 (9.3)	244 (9.6)	239 (9.4)	262 (10.3)	266 (10.5)	270 (10.6)	267 (10.5)	288 (11.3)	287 (11.3)	293 (11.5)	293 (11.5)	293 (11.5)	293 (11.5)
	H1	113 (4.4)	105 (4.1)	113 (4.4)	108 (4.3)	131 (5.2)	125 (4.9)	139 (5.5)	136 (5.4)	157 (6.2)	156 (6.1)	162 (6.4)	162 (6.4)	162 (6.4)	
	H2	51 (2.0)				61 (2.4)				80 (3.1)					
Face to face length	L*1	200 (7.9)				200 (7.9)				200 (7.9)					
Flange outside dia.	øD	125 (4.9)	108 (4.3)	124 (4.9)	115 (4.5)	140 (5.5)	127 (5.0)	155.4 (6.1)	150 (5.9)	155 (6.1)	152.4 (6.0)	165.1 (6.5)	165 (6.5)	165 (6.5)	
Pitch circle dia.	øC	90 (3.5)	79.2 (3.1)	88.9 (3.5)	85 (3.3)	105 (4.1)	98.6 (3.9)	114.3 (4.5)	110 (4.3)	120 (4.7)	120.7 (4.8)	127 (5.0)	125 (4.9)		
Bolt hole pitch	ø*	45	45	45	45	45	45	45	45	45	22.5	45	22.5	45	
Thickness (Except P,T Earthing)	T*2	17 (0.7)	19 (0.7)	17.2 (0.7)	20.5 (0.8)	21 (0.8)	19 (0.7)	21 (0.8)	20.5 (0.8)	23.6 (0.9)	21 (0.8)	19 (0.7)	21 (0.8)	22.1 (0.9)	25.4 (1.0)
Thickness (P,T Earthing)	T*2	28 (1.1)	30 (1.1)	28.2 (1.1)	31.5 (1.2)	32 (1.3)	30 (1.1)	32 (1.3)	31.5 (1.2)	34.6 (1.4)	32 (1.3)	30 (1.1)	32 (1.3)	33.1 (1.3)	36.4 (1.4)
Dia. of holes	øh	19 (0.7)	15.7 (0.6)	19.1 (0.8)	14 (0.6)	19 (0.7)	15.7 (0.6)	22.4 (0.9)	18 (0.7)	19 (0.7)	19.1 (0.7)	18 (0.7)	19.1 (0.7)	18 (0.7)	
Number of holes	N	4				4				4					
Weight	kg (lb)	4.3 (9.4)	4.6 (10.1)	3.6 (7.8)	4.8 (10.5)	4.6 (10.1)	6.3 (13.9)	6.6 (14.5)	5.9 (13.0)	8.2 (18.1)	7.9 (17.4)	7.7 (17.0)	7.8 (17.3)	8.2 (18.1)	9.8 (21.7)

- *1 When no earth ring is selected the face to face length is shorter by approx. 1.6mm (0.06in). The face to face length is longer by approx. 22mm (0.87in) for earth ring(P,T). The face to face length is longer by approx. 8.4mm (0.33in) for optional code/FRG.
- *2 The thickness(T) is longer by approx. 4.2mm (0.17in) for optional code/FRG.

SD5d.EPS

80mm(3in), 100mm(4in) Flange Type

Unit : mm (inch)

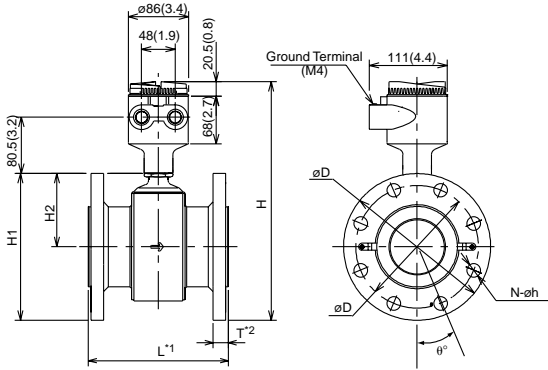

*1 When no earth ring is selected the face to face length is shorter by approx. 1.6mm (0.06 in).

The face to face length is longer by approx. 22mm (0.87in) for earth ring(P,T).

The face to face length is longer by approx. 8.4mm (0.33in) for optional code/FRG.

*2 The thickness(T) is longer by approx. 4.2mm(0.17in) for optional code/FRG.

Model	SE208DJ , SE208EJ										SE210DJ , SE210EJ																												
Nominal Size	80 (3)										100 (4)																												
Flange Type	J1	J2	A1	A2	D2	G1	J1	J2	A1	A2	D2	G1	J1	J2	A1	A2	D2	G1																					
Lining	Fluorocarbon PFA										Fluorocarbon PFA																												
Height	H	310	318	313	323	318	323	341	348	350	363	346	359	H1	179	187	182	192	187	192	210	217	219	232	215	224	H2	87 (3.4)					105 (4.1)						
	H1	(7.0)	(7.4)	(7.2)	(7.6)	(7.4)	(7.5)	(8.3)	(8.5)	(8.6)	(9.0)	(8.7)	(8.8)	(7.0)	(7.4)	(7.2)	(7.6)	(7.4)	(7.5)	(8.3)	(8.5)	(8.6)	(9.1)	(8.5)	(8.8)	(7.0)	(7.4)	(7.2)	(7.6)	(7.4)	(7.5)	(8.3)	(8.5)	(8.6)	(9.1)	(8.5)	(8.8)		
	H2																																						
Face to face length	L*1	200 (7.9)										250 (9.8)																											
Flange outside dia.	øD	185	200	190.8	209.6	200	211	210	225	228.6	254	220	238	øD	150	160	152.4	168.1	160	168	175	185	190.5	200.2	180	195	øC	150	160	152.4	168.1	160	168	175	185	190.5	200.2	180	195
Pitch circle dia.	øC	150	160	152.4	168.1	160	168	175	185	190.5	200.2	180	195	øC	150	160	152.4	168.1	160	168	175	185	190.5	200.2	180	195	øC	150	160	152.4	168.1	160	168	175	185	190.5	200.2	180	195
Bolt hole pitch	θ°	22.5	22.5	45	22.5	22.5	45	22.5	22.5	22.5	22.5	45	θ°	22.5	22.5	45	22.5	22.5	45	22.5	22.5	22.5	22.5	45	θ°	22.5	22.5	45	22.5	22.5	45	22.5	22.5	22.5	22.5	45			
Thickness (Except P.T Earth ring)	T*2	21.8	25.8	27.7	32.2	23.8	21.8	21.8	27.8	27.7	34.8	23.8	21.8	T*2	21.8	25.8	27.7	32.2	23.8	21.8	21.8	27.8	27.7	34.8	23.8	21.8	T*2	21.8	25.8	27.7	32.2	23.8	21.8	21.8	27.8	27.7	34.8	23.8	21.8
Thickness (P, T Earth ring)	T*2	32.8	36.8	38.7	43.2	34.8	32.8	32.8	38.8	37.7	45.8	34.8	32.8	T*2	32.8	36.8	38.7	43.2	34.8	32.8	32.8	38.8	37.7	45.8	34.8	32.8	T*2	32.8	36.8	38.7	43.2	34.8	32.8	32.8	38.8	37.7	45.8	34.8	32.8
Dia. of holes	øh	19	23	19.1	22.4	18	19	19	23	19.1	22.4	18	19	øh	19	23	19.1	22.4	18	19	19	23	19.1	22.4	18	19	øh	19	23	19.1	22.4	18	19	19	23	19.1	22.4	18	19
Number of holes	N	8	8	4	8	8	4	8	8	8	8	4	N	8	8	4	8	8	4	8	8	8	8	4	N	8	8	4	8	8	4	8	8	8	8	4			
Weight kg (lb)		10.2	14.1	14.8	16.1	12.1	12.5	11.8	15.7	16.4	22.9	13.7	24.1	Weight	22.5	31.1	32.7	35.5	26.7	27.6	25.9	34.5	36.0	50.4	30.1	53.0	Weight	22.5	31.1	32.7	35.5	26.7	27.6	25.9	34.5	36.0	50.4	30.1	53.0

Unit : mm (Approx. inch)

SD6d.eps

150mm(6in), 200mm(8in) Flange Type

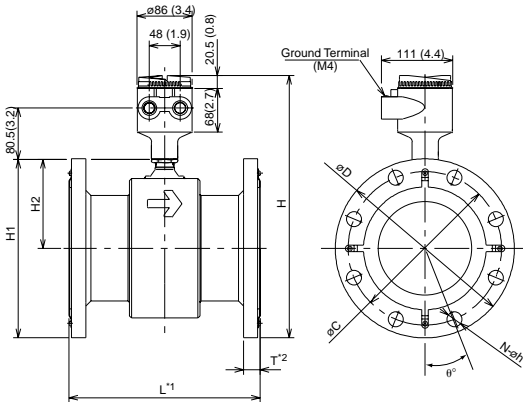

*1 When no earth ring is selected the face to face length is shorter by approx. 2mm (0.08in).

The face to face length is longer by approx. 32mm (1.3in) for earth ring(P,T).

The face to face length is longer by approx. 10.0mm (0.40in) for optional code/FRG.

*2 The thickness(T) is longer by approx. 5.0mm (0.20in) for optional code/FRG.

Model	SE215DJ , SE215EJ												SE220DJ , SE220EJ																										
Nominal Size	150 (6)												200 (8)																										
Flange Type	J1	J2	A1	A2	D2	G1	J1	J2	A1	A2	D1	D2	G1	J1	J2	A1	A2	D1	D2	G1																			
Lining	Fluorocarbon PFA												Fluorocarbon PFA																										
Face to face length (ISO)	L*1	300 (11.8)												350 (13.8)																									
Height	H	410	422.5	409.7	428.7	412.5	415	460	470	466.4	485.5	465	466	H	410	422.5	409.7	428.7	412.5	415	460	470	466.4	485.5	465	466	H	410	422.5	409.7	428.7	412.5	415	460	470	466.4	485.5	465	466
	H1	279	291.5	278.7	297.8	281.5	284	329	339	335.5	354.5	334	334	H1	279	291.5	278.7	297.8	281.5	284	329	339	335.5	354.5	334	334	H1	279	291.5	278.7	297.8	281.5	284	329	339	335.5	354.5	334	334
	H2																																						
Outside diameter	øD	280	305	279.4	317.5	285	290	330	350	342.9	381	340	342	øD	240	260	241.3	269.7	240	247	290	305	298.4	330.2	295	299	øD	240	260	241.3	269.7	240	247	290	305	298.4	330.2	295	299
Pitch circle dia.	øC	240	260	241.3	269.7	240	247	290	305	298.4	330.2	295	299	øC	240	260	241.3	269.7	240	247	290	305	298.4	330.2	295	299	øC	240	260	241.3	269.7	240	247	290	305	298.4	330.2	295	299
Bolt hole pitch	θ°	22.5	15	22.5	15	22.5	30	15	15	22.5	15	22.5	15	θ°	22.5	15	22.5	15	22.5	30	15	15	22.5	15	22.5	15	θ°	22.5	15	22.5	15	22.5	30	15	15	22.5	15	22.5	15
Thickness (Except P.T Earth ring)	T*2	27	33	30.4	41.5	27	27	27	35	49.4	46.1	29	29	T*2	27	33	30.4	41.5	27	27	27	35	49.4	46.1	29	29	T*2	27	33	30.4	41.5	27	27	27	35	49.4	46.1	29	29
Thickness (P,T Earth ring)	T*2	43	49	46.4	57.5	43	43	43	51	52.4	62.1	45	45	T*2	43	49	46.4	57.5	43	43	43	51	52.4	62.1	45	45	T*2	43	49	46.4	57.5	43	43	43	51	52.4	62.1	45	45
Dia. of holes	øh	23	25	22.3	22.3	22	19	23	25	22.3	25.4	22	19	øh	23	25	22.3	22.3	22	19	23	25	22.3	25.4	22	19	øh	23	25	22.3	22.3	22	19	23	25	22.3	25.4	22	19
Number of holes	N	8	12	8	12	8	6	12	12	8	12	8	N	8	12	8	12	8	6	12	12	8	12	8	N	8	12	8	12	8	6	12	12	8	12	8			
Weight kg (lb)		26.4	33.4	28.4	43.4	28.4	27.4	37.3	47.3	44.3	66.3	41.3	43.3	Weight	58.3	73.7	62.7	95.7	62.7	60.5	82.1	104.2	104.2	146.1	90.9	93.1	Weight	58.3	73.7	62.7	95.7	62.7	60.5	82.1	104.2	104.2	146.1	90.9	93.1

Unit : mm (Approx : inch)

SD7d.eps

250mm(10in) to 400mm(16in) Flange Type

Unit : mm (inch)

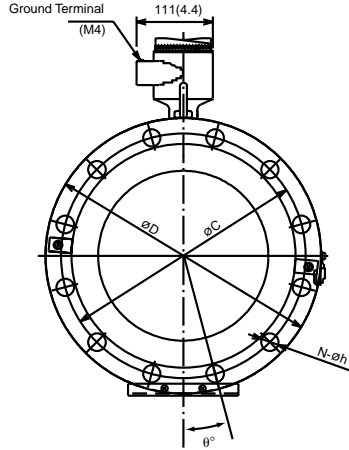
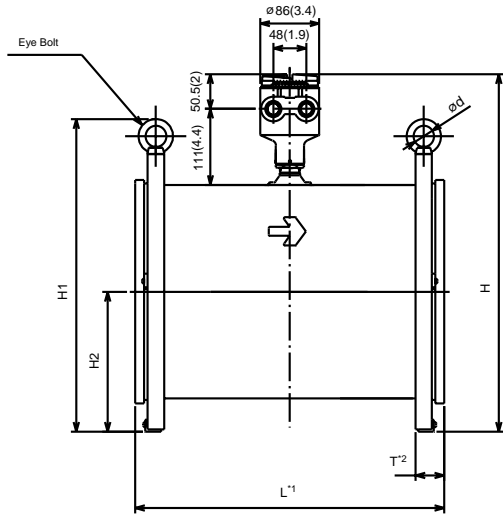

Unit : mm
(approx : inch)

*1 When no earth ring is selected the face to face length is shorter by approx. 26mm (1.02 inch) for 250mm(10 inch), 6mm (0.23 inch) for 300mm (12 inch), 10mm (0.4 inch) for 350mm (14 inch) and 400mm (16 inch).

*2 When no earth ring is selected the thickness (T) is shorter by approx. 13mm (0.51 inch) for 250mm(10 inch), 3mm (0.11 inch) for 300mm (12 inch), 5mm (0.20 inch) for 350mm (14 inch) and 400mm (16 inch).

Model	SE325						SE330						SE335				SE340						
Nominal Size	250(10)						300(12)						350(14)				400(16)						
Flange Type	A1□	A2□	D1□	D2□	G1□	J1□	J2□	A1□	A2□	D1□	D2□	G1□	J1□	J2□	A1□	D1□	G1□	J1□	A1□	D1□	G1□	J1□	
Lining	Fluorocarbon PFA						Fluorocarbon PFA						Fluorocarbon PFA				Fluorocarbon PFA						
Height	H	522.4 (20.6)	541.5 (21.3)	516.7 (20.3)	521.7 (20.5)	524.2 (20.6)	519.2 (20.4)	534.2 (21)	584.7 (23)	603.6 (23.7)	565.7 (22.3)	573.2 (22.5)	575.2 (22.6)	565.7 (22.3)	583.2 (22.9)	630.9 (24.8)	616.7 (24.3)	629.2 (24.8)	609.2 (24)	690.2 (27.2)	674.2 (26.5)	682.7 (26.8)	671.7 (26.4)
	H1	460.6 (18.1)	498.7 (19.6)	449.2 (17.7)	459.2 (18.1)	464.2 (18.3)	454.2 (17.8)	484.2 (19.1)	537.1 (21)	574.9 (22.6)	499.2 (19.6)	514.2 (20.2)	518.2 (20.4)	499.2 (19.6)	534.2 (21)	596.6 (23.5)	568.2 (22.4)	593.2 (23.4)	553.2 (21.8)	660.1 (26)	628.2 (24.7)	645.2 (25.4)	623.2 (24.5)
	H2	206.4 (8.1)	225.45 (8.9)	200.7 (7.9)	205.7 (8.1)	208.2 (8.2)	203.2 (8.0)	218.2 (8.6)	244.7 (9.6)	263.6 (10.3)	225.7 (8.9)	233.2 (9.2)	235.2 (9.3)	225.7 (8.9)	243.2 (9.6)	269.9 (10.6)	255.7 (10.1)	268.2 (10.6)	248.2 (9.8)	301.65 (11.9)	285.7 (11.2)	294.2 (11.6)	283.2 (11.1)
Eye bolt	M12 / 30						M12 / 30						M16 / 35				M16 / 35						
Face to face length (ISO)	L ¹ 450 (17.7)						500 (20)						550 (21.7)				600 (23.6)						
Outside diameter	ØD	406.4 (16)	444.5 (17.5)	395 (15.5)	405 (16)	410 (16.1)	400 (15.7)	430 (16.9)	482.9 (19)	520.7 (20)	445 (17.5)	460 (18)	464 (18.2)	445 (17.5)	480 (18.9)	533.4 (21)	505 (19.9)	530 (20.8)	490 (19.2)	596.9 (23.5)	565 (22.2)	582 (22.9)	560 (22)
Thickness	T ²	48.5 (1.9)	66 (2.6)	44 (1.7)	44 (1.7)	42 (1.7)	42 (1.7)	52 (2)	40 (1.6)	59 (2.3)	34 (1.3)	36 (1.4)	34 (1.3)	34 (1.3)	44 (1.7)	45 (1.8)	34 (1.3)	36 (1.4)	36 (1.4)	47 (1.8)	34 (1.3)	36 (1.4)	38 (1.5)
Pitch circle dia.	ØC	361.9 (14.2)	387.3 (15.2)	350 (13.8)	355 (14)	360 (14.2)	355 (14)	380 (15)	431.8 (17)	450.8 (18)	400 (16)	410 (16.3)	414 (16.3)	400 (15.7)	430 (16.9)	476.2 (18.7)	460 (18.1)	472 (18.6)	445 (17.5)	539.7 (21.2)	515 (20.3)	524 (20.6)	510 (20.1)
Bolt hole pitch	θ°	15	11.25	15	15	22.5	15	15	15	11.25	15	15	18	11.25	11.25	15	11.25	18	11.25	11.25	11.25	15	11.25
Dia. of holes	Øh	25.4 (1)	28.4 (1.1)	22 (0.9)	26 (1)	23 (0.9)	25 (1)	27 (1.1)	25.4 (1)	31.7 (1.2)	22 (0.9)	26 (1)	23 (0.9)	25 (1)	27 (1.1)	28.4 (1.2)	22 (0.9)	25 (1)	25 (1)	28.4 (1.1)	26 (1)	25 (1)	27 (1.1)
Number of holes	N	12	16	12	12	8	12	12	12	16	12	12	10	16	16	12	16	10	12	16	16	12	16
Weight	kg (lb)	76 (167.6)	81 (178.6)	70 (154.4)	71 (156.6)	70 (154.4)	70 (154.4)	73 (161)	96 (211.7)	104 (229.3)	87 (191.8)	88 (194)	87 (191.8)	87 (191.8)	91 (200.7)	123 (271.2)	107 (235.9)	107 (235.9)	107 (235.9)	168 (348.4)	135 (297.7)	135 (297.7)	135 (297.7)

SD9d.eps

Magnetic Flow Converter

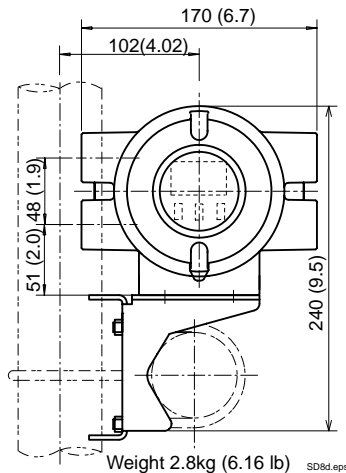
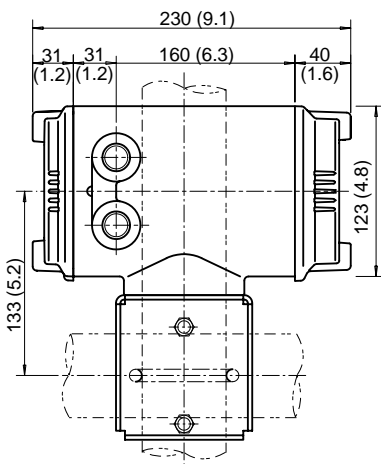

Weight 2.8kg (6.16 lb) SD8d.eps

GASKET

Please use compressed non-asbestos fiber gasket, PTFE gasket or the gasket which has equal elasticity. In case of /FRG, please use rubber gasket or others which has equal elasticity.

EARTH RING DIAMETER

Unit:mm (inch)	
Size	Earth Ring Inside Diameter
15(0.5)	15 (0.59)
25(1)	28 (1.10)
40(1.5)	41 (1.61)
50(2)	53 (2.09)
80(3)	81 (3.19)
100(4)	102 (4.02)
150(6)	146.1 (5.75)
200(8)	193.6 (7.62)
250(10)	wafer:243.7(9.6), flange:239.1(9.41)
300(12)	wafer:294.7(11.6), flange:291.3(11.47)
350(14)	323.4 (12.73)
400(16)	373.5 (14.70)

* Please ensure that the I.D. of the gasket does not protrude into the I.D. of the earth ring. (This dimension is also applied to when no earth ring is used.)

T11.EPS

ACCESSORIES

Integral type flowmeter(SE*MJ/NJ):**

- Data sheet 1
- Unit labels sheet 1
- Centering device 1set (in case of wafer type)
- Hexagonal wrench 1
(for special screw of converter)
- Plug 1 (in case of DC power supply version)

Remote type converter(SE14):

- Data sheet 1
- Unit labels sheet 1
- Hexagonal wrench 1
(for special screw of terminal cover/display cover.)
- Plug 1 (in case of DC power supply version)
- Mounting bracket 1set

Remote type flow tube(SE*DJ/EJ):**

- Centering device 1set (in case of wafer type)
- Hexagonal wrench 1
(for special screw of terminal cover)

SIZING DATA

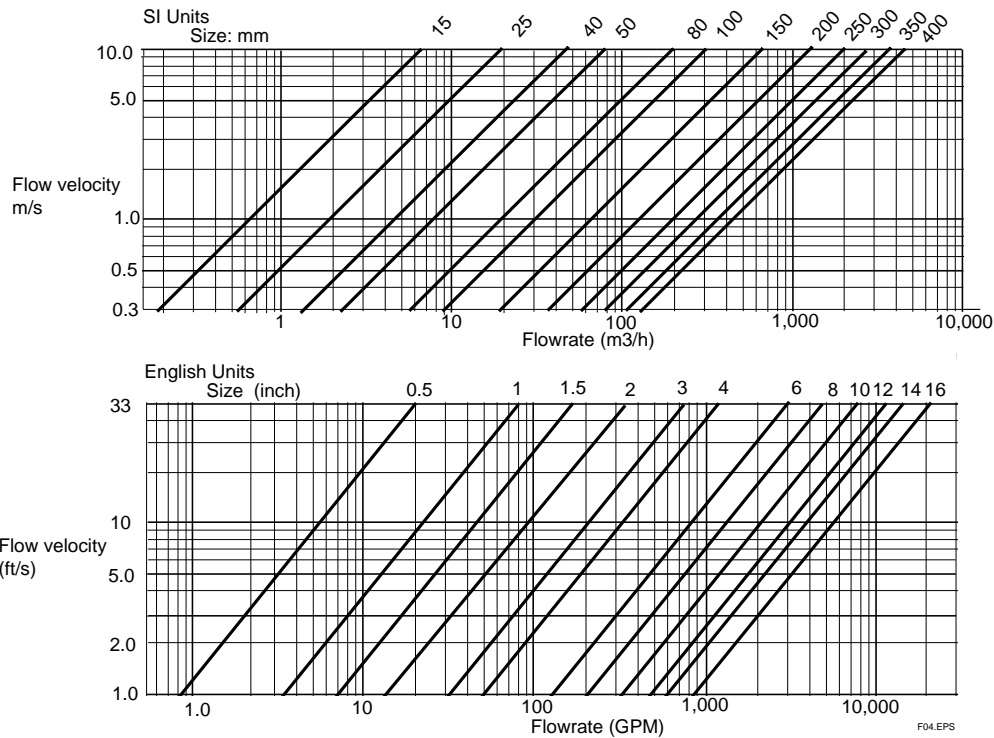

ORDERING INFORMATION

1. Model, specification and optional codes.
2. Fluid name.
3. Parameter setting. (Only when necessary)
 - (1) Flow rate span (at 100% output)
Example: Volume/time unit
 - (2) Totalizing pulse units
Example: Volume/Pulse, Pulse/time unit
 - (3) Transmission pulse units
Example: Volume/Pulse, Pulse/time unit
4. Tag number (16 characters maximum).
(Only when necessary in Name Plate)

RELATED INSTRUMENTS

- Related Products
- Calibrator for magnetic flow converter (AM012)..... GS 01E06K02-00E
 - BT200 Brain Terminal GS 1C0A11-E