**User's
Manual**

ADMAG AXF™

**AXFA11G
Magnetic Flowmeter
Remote Converter
[Hardware Edition/Software Edition]**

IM 01E20C01-01E

vigilantplant.™

Contents

1.	INTRODUCTION	1-1
1.1	Using the Magnetic Flowmeter Safely	1-2
1.2	Warranty	1-2
1.3	Combination Remote Flowtubes	1-3
2.	HANDLING PRECAUTIONS	2-1
2.1	Checking Model and Specifications	2-1
2.2	Accessories	2-1
2.3	Storage Precautions	2-1
2.4	Installation Location Precautions	2-1
3.	INSTALLATION	3-1
3.1	Installation Location	3-1
3.2	Mounting	3-1
4.	WIRING	4-1
4.1	Wiring Precautions	4-1
4.2	Cables	4-1
4.3	Wiring Ports	4-2
4.4	Wiring Connections	4-4
4.4.1	Removing Cover	4-4
4.4.2	Terminal Configuration	4-4
4.4.3	Precautions for Wiring of Power Supply Cables	4-5
4.4.4	DC Power Connection	4-5
4.4.5	Grounding	4-6
4.4.6	Wiring the Remote Flowtube with the AXFA11 Converter	4-6
4.4.7	Connecting to External Instruments	4-7
5.	BASIC OPERATING PROCEDURES (USING THE DISPLAY UNIT)	5-1
5.1	Operating Panel Configuration and Functions	5-1
5.2	Display Unit Setting Methods	5-3
5.2.1	Display Mode → Setting Mode	5-3
5.2.2	Setting Mode	5-5
5.3	Parameter Setting Procedure	5-5
5.3.1	Setting Example for Selection-Type Data: Flow rate units	5-5
5.3.2	Setting Example for Numeric-Type Data: Flow rate span	5-7
5.3.3	Setting Example for Alphanumeric-Type Data: Tag number	5-8

6.	PARAMETER DESCRIPTION	6-1
6.1	Parameters	6-1
6.2	Parameter Lists	6-1
6.3	Parameter List Overview	6-2
6.4	Parameter Description	6-12
	(1) Menu B: Easy Setup items	6-12
	(2) Menu C: Basic Setting items	6-15
	(3) Menu D: Total Setting items	6-17
	(4) Menu E: Pulse Setting items	6-19
	(5) Menu F: Status Functions Setting items	6-20
	(6) Menu G: Alarm Setting items	6-25
	(7) Menu H: Display Setting items	6-29
	(8) Menu J: Auxiliary Function Setting items	6-30
	(9) Menu K: Diagnostic Function Setting items	6-32
	(10) Menu M: Automatic Zero Adjustment Function Setting items	6-33
	(11) Menu N: Loop Test Setting items	6-33
	(12) Menu P: Parameter Protection items	6-34
6.5	Alarm Functions	6-35
6.5.1	Alarm Levels	6-35
6.5.2	Alarm Selection	6-36
6.5.3	Alarms & Warning Messages	6-38
7.	OPERATION VIA BRAIN TERMINAL (BT200)	7-1
7.1	BT200 Basic Operations	7-1
7.1.1	Key Layout and Display	7-1
7.1.2	Key Descriptions	7-1
7.2	AXFA11 Operation Using a BT200	7-3
7.2.1	BT200 Connection	7-3
7.2.2	The data update and upload/download function of BT200	7-3
7.2.3	BT200 Screens & Flow Rate Data Display	7-4
7.3	Parameter Setting Using a BT200	7-4
7.3.1	BT200 Setting of Selection-Type Data: Flow rate units	7-5
7.3.2	BT200 Setting of Numeric-Type Data: Flow rate span	7-6
7.3.3	BT200 Setting of Alphanumeric-Type Data: Tag number	7-7
8.	OPERATION VIA HART COMMUNICATOR	8-1
8.1	Conditions of Communication Line	8-2
8.1.1	Interconnectwion between AXFA11 and HART Communicator	8-2
8.1.2	Communication Line Requirements	8-2
8.2	Basic Operation of the HART Communicator (Model 275)	8-3
8.2.1	Keys and Functions	8-3
8.2.2	Display	8-4
8.2.3	Calling Up Menu Addresses	8-4
8.2.4	Entering, Setting and Sending Data	8-5
8.3	Parameters	8-5
8.3.1	Parameter Configuration	8-5
8.3.2	Data Renewing	8-5
8.3.3	Checking for Problems	8-6
8.3.4	Setting Parameters	8-6
8.3.5	Menu Tree	8-21

9.	ACTUAL OPERATION.....	9-1
9.1	Pre-operation Zero Adjustment.....	9-1
9.1.1	Zero Adjustment Using Display Unit Switches.....	9-2
9.1.2	Zero Adjustment via External Status Input.....	9-3
10.	MAINTENANCE	10-1
10.1	Components Replacement.....	10-1
10.1.1	Fuse Replacement.....	10-1
10.1.2	Display Unit Replacement.....	10-1
10.1.3	Amplifier Replacement.....	10-2
10.2	Setting of Switches.....	10-2
10.2.1	Setting of Burnout Switch.....	10-2
10.2.2	Setting of Write Protect Switch.....	10-3
10.3	Troubleshooting.....	10-4
10.3.1	No Indication.....	10-4
10.3.2	Unstable Zero.....	10-5
10.3.3	Disagreement Between Indication and Actual Flow.....	10-6
11.	OUTLINE.....	11-1

REVISION RECORD

1. INTRODUCTION

This instrument has been adjusted at the factory before shipment.

To ensure correct use of the instrument, please read this manual thoroughly and fully understand how to operate the instrument before operating it.

■ Regarding This User's Manual

- This manual should be provided to the end user.
- Before use, read this manual thoroughly to comprehend its contents.
- The contents of this manual may be changed without prior notice.
- All rights are reserved. No part of this manual may be reproduced in any form without Yokogawa's written permission.
- Yokogawa makes no warranty of any kind with regard to this material, including, but not limited to, implied warranties of merchantability and suitability for a particular purpose.
- All reasonable effort has been made to ensure the accuracy of the contents of this manual. However, if any errors or omissions are found, please inform Yokogawa.
- Yokogawa assumes no responsibilities for this product except as stated in the warranty.
- Please note that this user's manual may not be revised for any specification changes, construction changes or operating part changes that are not considered to affect function or performance.
- If the customer or any third party is harmed by the use of this product, Yokogawa assumes no responsibility for any such harm owing to any defects in the product which were not predictable, or for any indirect damages.



NOTE

Please refer to manual IM 01E20D01-01E for information of the AXF Remote Flowtube.

■ Safety and Modification Precautions

- The following general safety precautions must be observed during all phases of operation, service, and repair of this instrument. Failure to comply with these precautions or with specific WARNINGS given elsewhere in this manual violates safety standards of design, manufacture, and intended use of the instrument. Yokogawa assumes no liability for the customer's failure to comply with these require-

ments. If this instrument is used in a manner not specified in this manual, the protection provided by this instrument may be impaired.

- Yokogawa will not be liable for malfunctions or damage resulting from any modification made to this instrument by the customer.
- The following safety symbol marks are used in this user's manual and instrument.



WARNING

A WARNING sign denotes a hazard. It calls attention to procedure, practice, condition or the like, which, if not correctly performed or adhered to, could result in injury or death of personnel.



CAUTION

A CAUTION sign denotes a hazard. It calls attention to procedure, practice, condition or the like, which, if not correctly performed or adhered to, could result in damage to or destruction of part or all of the product.



IMPORTANT

An IMPORTANT sign denotes that attention is required to avoid damage to the instrument or system failure.



NOTE

A NOTE sign denotes information necessary for essential understanding of operation and features.



Protective grounding terminal



Functional grounding terminal
(This terminal should not be used as a protective grounding terminal.)



Alternating current



Direct current

1.1 Using the Magnetic Flowmeter Safely



WARNING

(1) Installation

- Installation of the magnetic flowmeter must be performed by expert engineer or skilled personnel. No operator shall be permitted to perform procedures relating to installation.
- The magnetic flowmeter is a heavy instrument. Be careful that no damage is caused to personnel through accidentally dropping it, or by exerting excessive force on the magnetic flowmeter. When moving the magnetic flowmeter, always use a trolley and have at least two people carry it.
- When the magnetic flowmeter is processing hot fluids, the instrument itself may become extremely hot. Take sufficient care not to get burnt.
- Where the fluid being processed is a toxic substance, avoid contact with the fluid and avoid inhaling any residual gas, even after the instrument has been taken off the piping line for maintenance and so forth.
- Do not apply excessive weight, for example, a person stepping on the magnetic flowmeter.
- All procedures relating to installation must comply with the electrical code of the country where it is used.

(2) Wiring

- The wiring of the magnetic flowmeter must be performed by expert engineer or skilled personnel. No operator shall be permitted to perform procedures relating to wiring.
- When connecting the wiring, check that the supply voltage is within the range of the voltage specified for this instrument before connecting the power cable. In addition, check that no voltage is applied to the power cable before connecting the wiring.
- The protective grounding must be connected securely at the terminal with the \oplus mark to avoid danger to personnel.

(3) Operation

- Do not open the cover until the power has been off for at least 10 minutes. Only expert engineer or skilled personnel are permitted to open the cover.

(4) Maintenance

- Maintenance on the magnetic flowmeter should be performed by expert engineer or skilled personnel. No operator shall be permitted to perform any operations relating to maintenance.
- Always conform to maintenance procedures outlined in this manual. If necessary, contact Yokogawa.
- Care should be taken to prevent the build up of dirt, dust or other substances on the display panel glass or data plate. If these surfaces do get dirty, wipe them clean with a soft dry cloth.

1.2 Warranty

- The terms of this instrument that are guaranteed are described in the quotation. We will make any repairs that may become necessary during the guaranteed term free of charge.
- Please contact our sales office if this instrument requires repair.
- If the instrument is faulty, contact us with concrete details about the problem and the length of time it has been faulty, and state the model and serial number. We would appreciate the inclusion of drawings or additional information.
- The results of our examination will determine whether the meter will be repaired free of charge or on an at-cost basis.

■ The guarantee will not apply in the following cases:

- Damage due to negligence or insufficient maintenance on the part of the customer.
- Problems or damage resulting from handling, operation or storage that violates the intended use and specifications.
- Problems that result from using or performing maintenance on the instrument in a location that does not comply with the installation location specified by Yokogawa.
- Problems or damage resulting from repairs or modifications not performed by Yokogawa or someone authorized by Yokogawa.
- Problems or damage resulting from inappropriate reinstallation after delivery.
- Problems or damage resulting from disasters such as fires, earthquakes, storms, floods, or lightning strikes and external causes.

1.3 Combination Remote Flowtubes



IMPORTANT

- The AXFA11 Magnetic Flowmeter Converter should be used in combination with the following remote flowtubes:
AXFA11G ⇔ AXF002□-N to AXF26L□-N
Contact Yokogawa before using it in combination with flowtubes other than those listed above.
 - The model AXF□□□C remote flowtube with optional code JF3 (TIIS flame proof type) cannot be combined with the AXFA11 converter. In this case, use the AXFA14 converter.
 - If the converter combined with the AXF magnetic flowmeter remote flowtube is changed from the AXFA11 to AXFA14 or vice versa, the meter factor of the remote flowtube must be readjusted according to its flow calibration.
-



CAUTION

In case of combination with the explosion proof type remote flowtube (AXF□□□C-N) for CENELEC ATEX, FM, and CSA certification, please see the manual IM 01E20D01-01E. The construction of the instrument, installation, external wiring, maintenance, and repair are strictly restricted, and non-observance or negligence of these restriction would result dangerous condition.

2. HANDLING PRECAUTIONS

This instrument has been inspected carefully at the factory before shipment. When the instrument is delivered, visually check that no damage has occurred during transportation.

Read this section carefully as it contains important information on handling this instrument. Refer to the relevant sections for information not contained in this section. If you have any problems or questions, please contact Yokogawa sales office.

2.1 Checking Model and Specifications

The model code and specifications are found on the data plate located on the outside of the case. Check that the model code and specifications match what you have ordered.

Be sure you have your model number and serial number available when contacting Yokogawa.

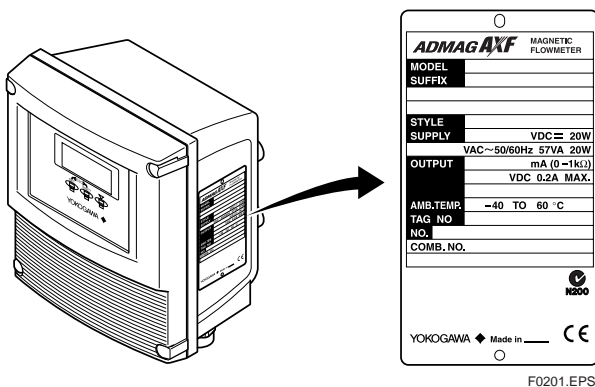

2.2 Accessories

Check that the parts shown below are included in the package:

- Spare fuse: 1 piece (Use this spare fuse for this product only)
 - Power supply code 1; T2.5 A, 250 V
 - Power supply code 2; T3.15A, 250 V
 (The spare fuse is taped to the lower left wall inside the case. T: time-lag fuse)
- Mounting hardware: 1 set

2.3 Storage Precautions

If the instrument is to be stored for a long period of time after delivery, observe the following points.

- The instrument should be stored in its original packing condition in the storage location.
- Select a storage location that fulfils the following conditions:
 - A place where it will not be exposed to rain or water
 - A place subject to minimal vibrations or shocks
 - Temperature and humidity levels should be as follows:

Temperature: -30 to 70°C

Humidity: 5 to 80% RH (no condensation)

The preferred ambient temperature and humidity levels are 25°C and approximately 65% RH.

- If the AXFA11 is transferred to the installation site and stored without being installed, its performance may be impaired due to the infiltration of rainwater and so forth. Be sure to install and wire the AXFA11 as soon as possible after transferring it to the installation location.

2.4 Installation Location Precautions

Select the installation location with consideration to the following items to ensure long-term stable operation of the instrument.

■ Ambient Temperature:

Avoid installing the instrument in locations with constantly fluctuating temperatures. If the location is subject to radiant heat from the plant, provide heat insulation or improve ventilation.

■ Atmospheric Condition:

Avoid installing the instrument in a corrosive atmosphere. In situations where this is unavoidable, consider ways to improve ventilation and to prevent rainwater from entering and being retained in the conduit pipes.

■ Vibrations or Shocks:

Avoid installing the instrument in a place subject to shocks or vibrations.

3. INSTALLATION



WARNING

Installation of the magnetic flowmeter must be performed by expert engineer or skilled personnel. No operator shall be permitted to perform procedures relating to installation.

3.1 Installation Location



IMPORTANT

Install the instrument in a location where it is not exposed to direct sunlight. For ambient temperature, refer to Chapter 11 "OUTLINE".

The instrument may be used in an ambient humidity where the RH ranges from 0 to 100%. However, avoid long-term continuous operation at relative humidity above 95%.

3.2 Mounting

This instrument can be mounted using surface mounting, 2-inch pipe mounting, or panel mounting.

● Surface Mounting (Wall Mounting)

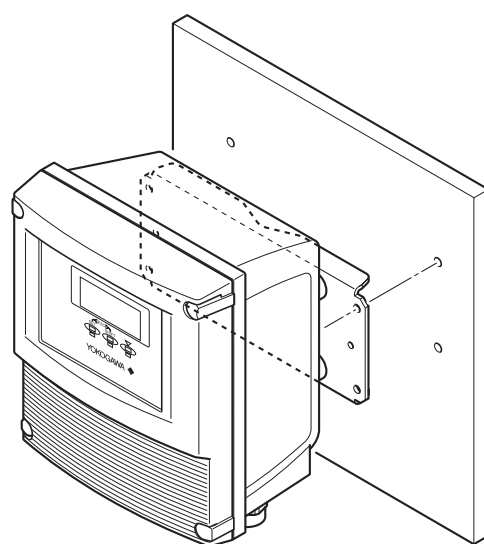

Unit: mm
(approx. inch)

For surface mounting, use the mounting fixture provided, using M6 screws. These M6 screws must be provided by the user.

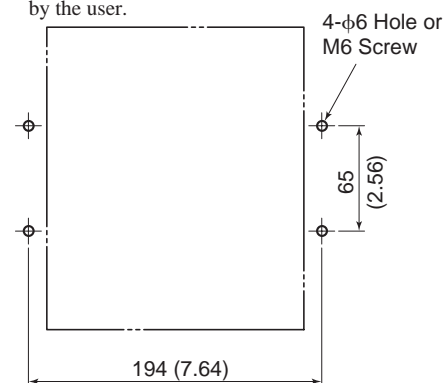

F0301.EPS

Figure 3.2.1 Surface Mounting



IMPORTANT

Mounting fixture on equipment intended to be mounted on a wall or ceiling shall withstand a force of four times the weight of the equipment (AXFA11: 3.3kg (7.3 lb)).

● 2-inch Pipe Mounting

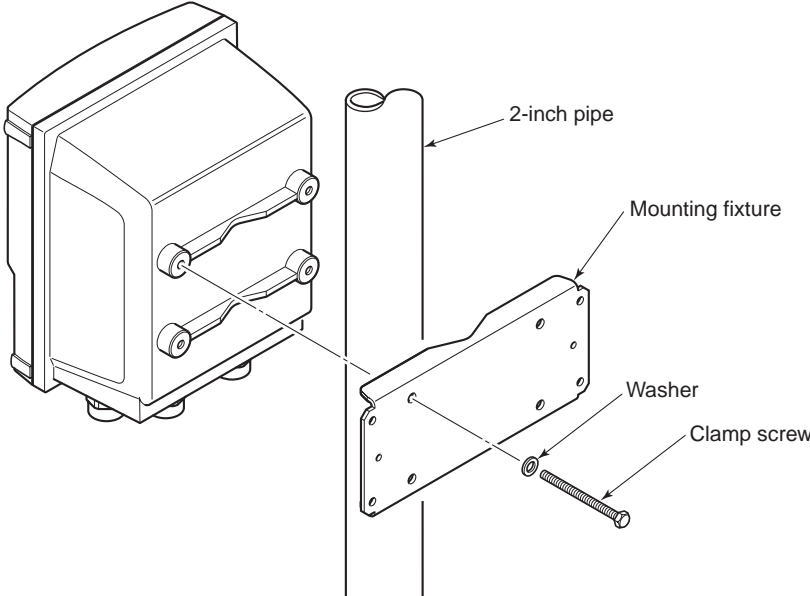

Pass the four clamp screws through the mounting fixture, position it on the 2-inch pipe, and then fasten the AXFA11 in place.

F0302.EPS

Figure 3.2.2 2-inch Pipe Mounting

● Panel Mounting

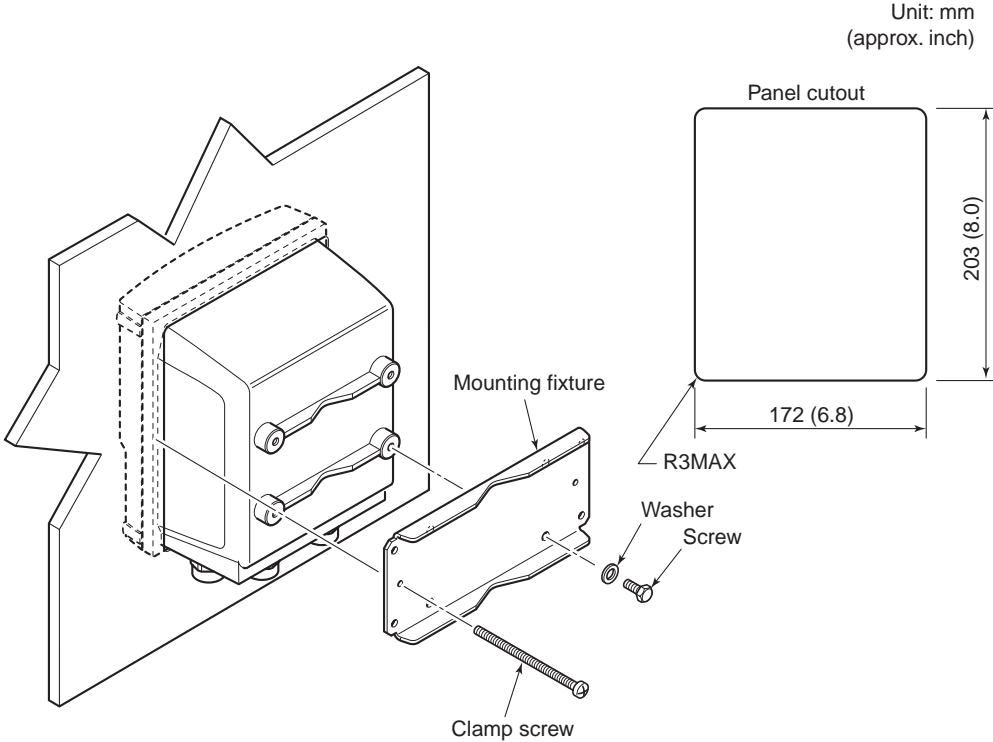

Fit the AXFA11 into the panel. Then attach the mounting fixture to the AXFA11 using the screw and the washer, and secure the instrument with the two clamp screws.

F0303.EPS

Figure 3.2.3 Panel Mounting

4. WIRING

This section describes the wiring on the converter side only. For information relating to wiring on the flowtube side, refer to the user's manual of the AXF Remote Flowtube (IM 01E20D01-01E).

WARNING

The wiring of the magnetic flowmeter must be performed by expert engineer or skilled personnel. No operator shall be permitted to perform procedures relating to wiring.

CAUTION

Once all wiring is complete, check the connections before applying power to the instrument. Improper arrangements or wiring may cause a unit malfunction or damage.

4.1 Wiring Precautions

Be sure to observe the following precautions when wiring:

CAUTION

- In cases where the ambient temperature exceeds 50°C (122°F), use external heat-resistant wiring with a maximum allowable temperature of 70°C (158°F) or above.
- Do not connect cables outdoors in wet weather in order to prevent damage from condensation and to protect the insulation.
- Do not splice the cable between the flowtube terminal and the converter if it is too short. Replace the short cable with a cable that is the appropriate length.
- All the cable ends must be provided with round crimp-on terminals and be securely wired.
- The signal cables must be routed in separate steel conduit tubes 16 (JIS C 8305) or flexible conduit tubes 15 (JIS C 8309).
- Always route the power and output signal cables in separate steel conduit tubes, except when the power supply voltage is 24 V and

four-core cables are used for wiring. Keep conduits or flexible tubes watertight using sealing tape.

- Ground the remote flowtube and the converter separately.
- Cover each shield of the signal cable with vinyl tube or vinyl tape to avoid contact between two shields or between a shield and a case.
- When waterproof glands or union equipped waterproof glands are used, avoid tightening the glands with an excessive torque.
- Be sure to turn power off before opening the cover.
- Before turning the power on, tighten the cover securely.

4.2 Cables

(1) Dedicated Signal Cable (AXFC)

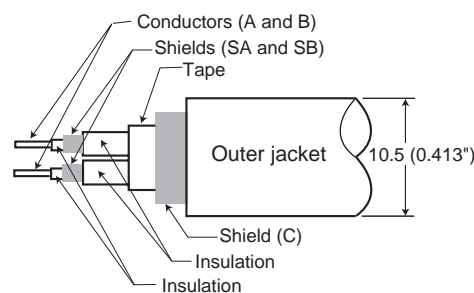

F0401.EPS

Figure 4.2.1 Dedicated Signal Cable AXFC

The flow signal is transmitted via this dedicated cable. The cable is constructed with double shielding over the two conductors, and heat-resistant vinyl is used for the outer jacket material.

Finished diameter: 10.5 mm (0.413")
 Maximum length: 200 m (660 ft)
 Maximum temperature: 80°C (176°F)

IMPORTANT

If the cable is longer than required, cut off any extra length rather than coiling it up, and terminate the conductors as shown in Figure 4.2.2. Avoid using junction terminal boards to extend the cable length, as this will interrupt the shielding.

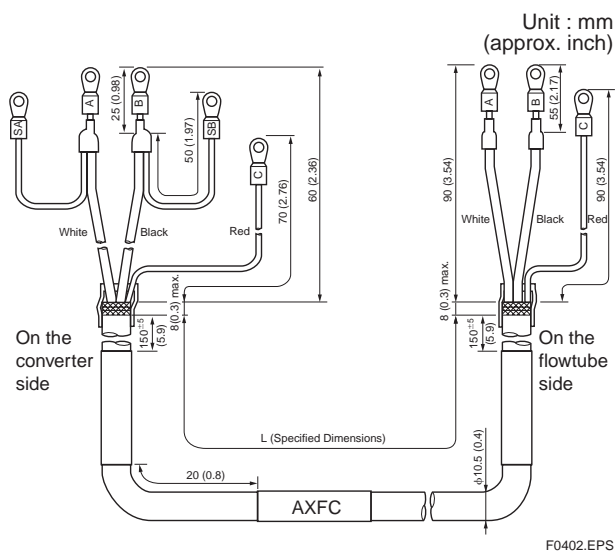

Figure 4.2.2 Treatment of Dedicated Signal Cables

CAUTION

- As crimp terminals A, B, SA, SB and C have their own electrical potentials, securely insulate them so as not to come in contact with one another.
- To prevent a shield from coming in contact with another shield or the case, cover each shield with a vinyl tube or wrap it in vinyl tape.

NOTE

Conductors A and B carry the signal from the electrodes, and C is at the potential of the liquid (signal common). Shields SA and SB are kept at the same potentials as the individual electrodes (these are actively driven shields.) This is done to reduce the effect of the distributed capacitance of the cable at long cable length. Note that, since the signals from the individual electrodes are impedance converted inside the converter, errors will result if they come in contact with any other component. Great care must be taken in the cable end treatment.

(2) Excitation Cable/Power Cable/Output Cable

Use polyvinyl chloride insulated and sheathed control cables (JIS C 3401) or polyvinyl chloride insulated and sheathed portable power cables (JIS C 3312) or the equivalent.

Outer Diameter: 6.5 to 12 mm (0.26 to 0.47 in.)
7.5 to 12 mm (0.30 to 0.47 in.) for optional code EG, EU and EW

6 to 12mm (0.24 to 0.47 in.) for optional code EP

Nominal Cross Section (Single wire): 0.5 to 2.5 mm²
Nominal Cross Section (Stranded wire): 0.5 to 1.5 mm²

In case of power cable, Green/Yellow covered conductor shall be used only for connection to PROTECTIVE CONDUCTOR TERMINALS. Conform to IEC227, IEC245 or equivalent national authorization.

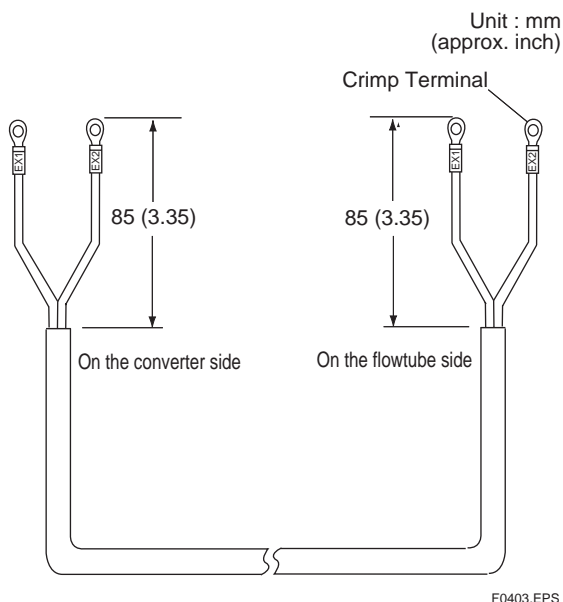

Figure 4.2.3 End Treatment of Excitation Cable

NOTE

- For excitation and power cables, always use a crimp terminal with an insulation cover.
- Use crimp tools from the manufacturer of the crimp terminal you want to use to connect the crimp terminal and cable.
- Use crimp tools that are appropriate for the diameter of the cable to be connected.

4.3 Wiring Ports

This instrument is of watertight construction as stipulated in JIS C0920-1982 (Tests to prove protection against ingress of water and degrees of protection against ingress of solid objects for electrical equipment.) It is shipped with a wiring bracket (waterproof gland or waterproof gland with union) or a plastic gland attached, only in cases where an optional specification is selected for the wiring port.

(1) When there are no particular optional specifications

The wiring port is sealed with a cap (not water-proof) that must be removed before wiring. At this time, handle the wiring port in accordance with the JIS C0920-1982 mentioned above.

(2) Wiring using waterproof glands



IMPORTANT

To prevent water or condensation from entering the converter housing, waterproof glands are recommended. Do not over-tighten the glands or damage to the cables may result. Tightness of the gland can be checked by confirming that the cable is held firmly in place.

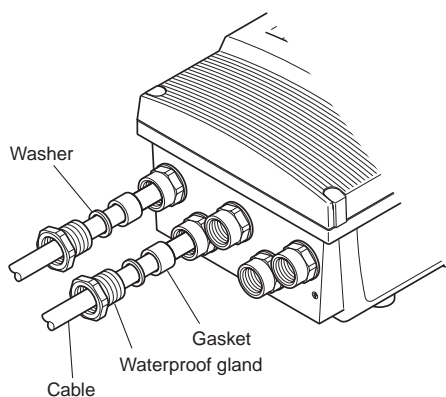

F0404.EPS

Figure 4.3.1 Waterproof Gland (Optional Code EG)

For working on the electric wire tubes or the flexible tubes (PF1/2), remove the waterproof gland and attach them directly to the wiring port.

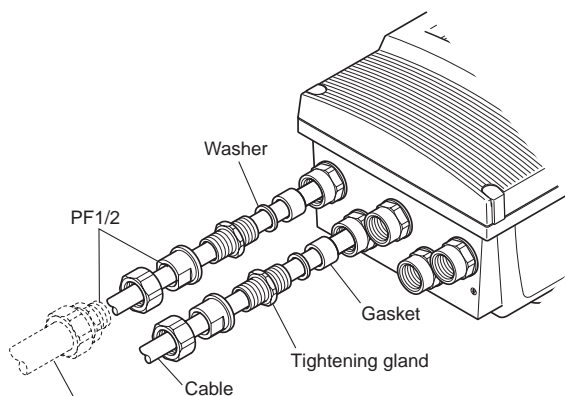

When working on conduit pipes or flexible pipes (PF1/2 only)

F0405.EPS

Figure 4.3.2 Waterproof Gland with Union Joint (Optional Code EU)

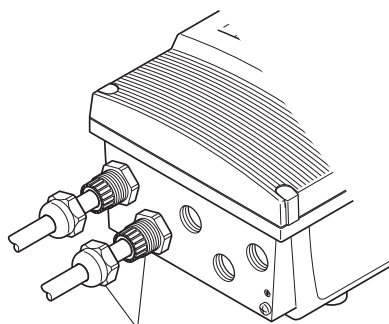

Plastic gland

F0406.EPS

Figure 4.3.3 Plastic Gland (Optional Code EP)

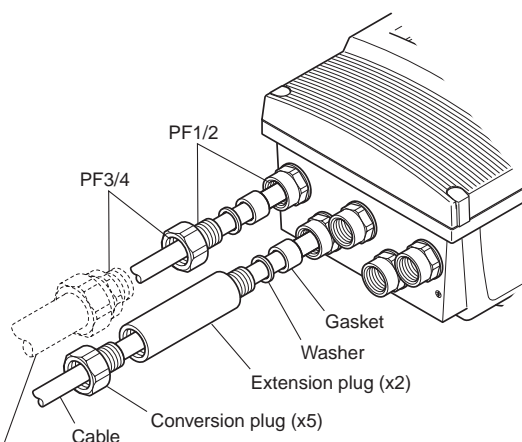

When working on electric wire tube or flexible tube (PF3/4)
 * When connecting PF1/2, remove the conversion plug and connect directly to wiring port.

F0407.EPS

Figure 4.3.4 PF3/4 Waterproof Gland (Optional Code EW)

(3) Conduit Wiring

When wiring the conduits, pass the conduit through the wiring connection port, and utilize the waterproof gland to prevent water from flowing in. Place the conduit pipe on an angle as shown in Figure 4.3.5. Install a drain valve at the low end of the vertical pipe, and open the valve regularly.

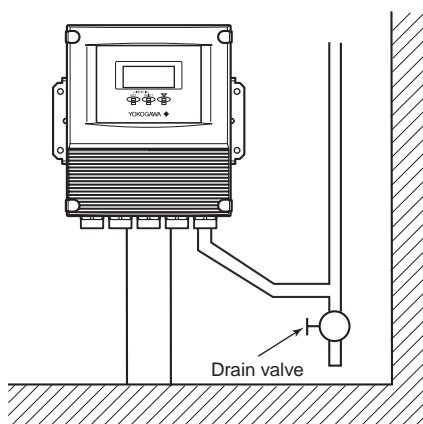

F0408.EPS

Figure 4.3.5 Conduit Wiring

4.4 Wiring Connections

4.4.1 Removing Cover

While supporting the front of the cover with your hand, flip the connecting screw protective cover over, and remove the four connecting screws.

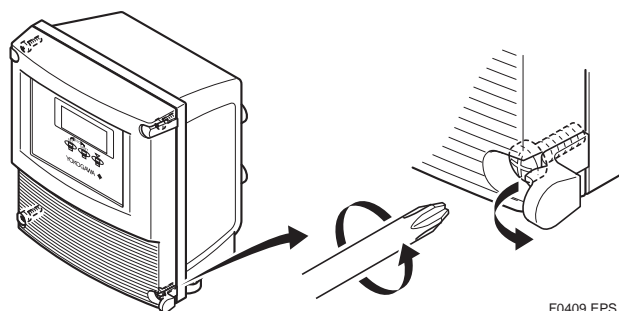

F0409.EPS

Figure 4.4.1 Removing the Front Cover

4.4.2 Terminal Configuration

When the cover is removed, the connection terminals will be visible. The terminal configuration labels are attached in the position shown in Figure 4.4.2.

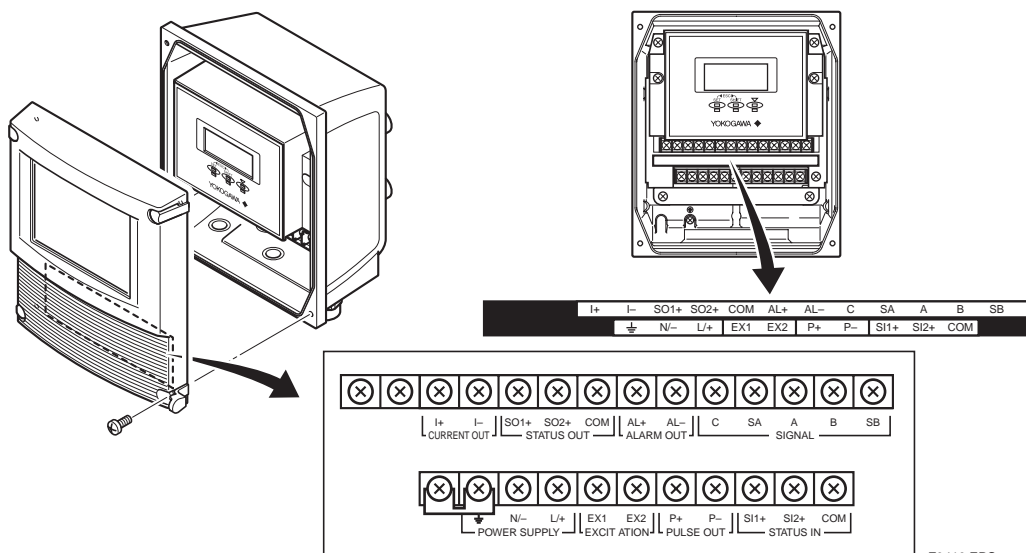

F0410.EPS

Figure 4.4.2 Terminal Layout Labels Position

The description of the terminal symbols is shown in Table 4.4.1.

Table 4.4.1 Terminal Symbols

Terminal Symbols	Description	Terminal Symbols	Description
SIGNAL	Flow signal input	STATUS IN	Status input (Two input)
ALARM OUT	Alarm output	PULSE OUT	Pulse output
STATUS OUT	Status output (Two output)	EXCITATION	Excitation current output
CURRENT OUT	Current output 4 to 20mA DC	POWER SUPPLY	Power supply
			Functional grounding
			Protective grounding (Outside of the terminal)

T0401.EPS

IMPORTANT

Do not wire the terminal without terminal symbols in terminal layout labels.

4.4.3 Precautions for Wiring of Power Supply Cables

When connecting to the power supply, observe the points below. Failure to comply with these warnings may result in an electric shock or damage to the instrument.

WARNING

- Ensure that the power supply is OFF in order to prevent electric shocks.
- Ensure the protective grounding terminal is grounded before turning the power on.
- Use insulating sleeve crimp terminals (for 4-mm screws) for the power supply wiring and protective grounding wiring.
- To prevent electric shocks, ensure the electrical wiring cover (transparent) is attached.
- Install an external switch or circuit breaker as a means to turn the power off (capacitance; 15A, conforming to IEC947-1 and IEC947-3). Locate this switch either near the instrument or in other places facilitating easy operation. Affix a “Power Off Equipment” label to this external switch or circuit breaker.

Wiring Procedure

1. Turn the instrument's power off, and remove the wiring cover (transparent).
2. Wire the power supply cable and the functional grounding cable to the power supply terminals.

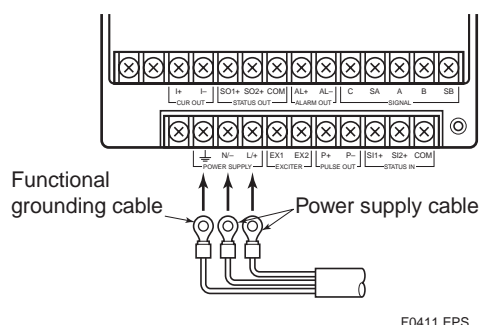

F0411.EPS

Figure 4.4.3 Electric Cable Wiring

3. Reattach the electrical wiring cover (transparent).

4.4.4 DC Power Connection

When using DC power as the power supply for the converter, give attention to the following points.

(1) Connecting Power Supply

IMPORTANT

Do not connect power supply with reversed polarities.

L/+ terminal: connect +

N/- terminal: connect -

IMPORTANT

Do not connect power supply with 100 to 240 V AC or 100 to 120 V DC in the case of a 24 V power supply version (power supply code 2). It will give a damage to the converter.

(2) Required Power Supply Voltages

IMPORTANT

When using a 24 V power supply, the specification for the supply voltage is 24 V (–15% to +20%), but the input voltage of the converter drops due to cable resistance therefore it must be used within the following ranges.

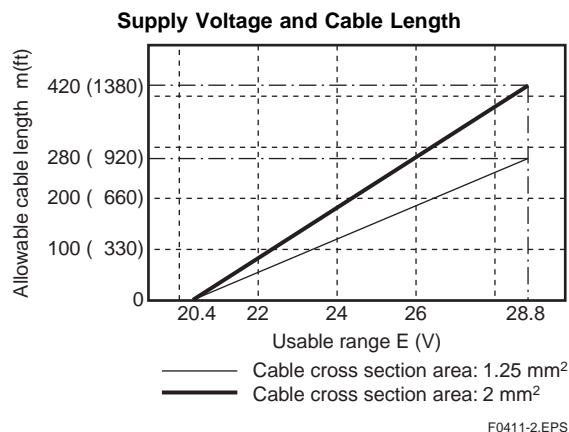

(3) Setting Power Supply Frequency

IMPORTANT

Set the local commercial power frequency in order to eliminate the effect of induction noise from the commercial power supply.

Refer to “Chapter 6: Parameter Description” in this manual. Parameter No. **J30** and **J31**.

4.4.5 Grounding

CAUTION

Be sure to connect the protective grounding of the AXFA11 with a cable of 2mm² or larger cross section in order to avoid electrical shock to the operators and maintenance engineers and to prevent the influence of external noise. Connect the grounding wire to the ⊕ mark (100 Ω or less).

IMPORTANT

When optional code A (lighting protector) is selected, the ground should satisfy Class C requirements (grounding resistance, 10 Ω or less).

- The protective grounding terminals ⊕ are located on the inside and outside of the terminal area.
- Use 600 V vinyl insulation wires as the grounding wires.

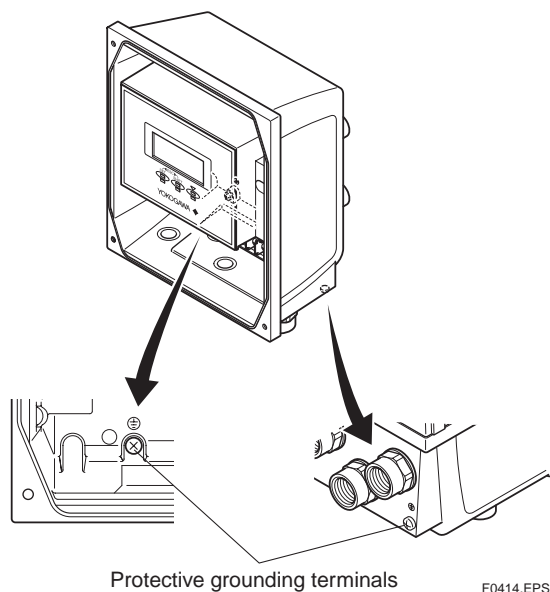

Figure 4.4.4 Protective Grounding Terminal Location

4.4.6 Wiring the Remote Flowtube with the AXFA11 Converter

WARNING

Before wiring, be sure that the power supply for AXFA11 converter has been turned off to prevent an electrical shock.

(1) Connection with the Remote Flowtube (General-Purpose Use, Submersible Type, Sanitary Type, Size 2.5 to 400 mm (0.1 to 16 in.))

Connect wiring as shown in the figure below.

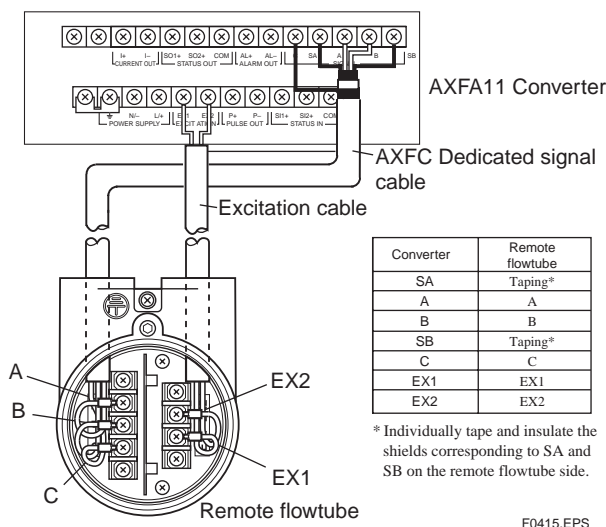

Figure 4.4.5 Wiring Diagram

(2) Connection with the Remote Flowtube (Explosion proof Type, Size 2.5 to 400 mm (0.1 to 16 in.))

IMPORTANT

In case of TIIS Flame proof type, a remote flowtube cannot be combined with AXFA11 converter. In this case, use the AXFA14 converter.

In case of explosion proof type for CENELEC ATEX, FM, and CSA certification, connect wiring as shown in the figure below.

In case of the explosion proof type, the protective grounding \oplus of remote flowtube must be connected to a suitable IS grounding system. In that case, \perp (functional grounding terminal) need not be connected.

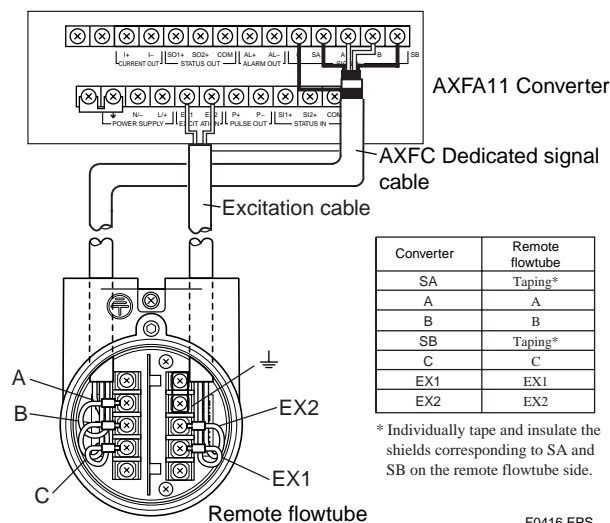

Figure 4.4.6 Wiring Diagram

(3) Connection with the Remote Flowtube (General-Purpose Use, Submersible Type, Size 500 to 1000 mm (20 to 40 in.))

Connect wiring as shown in the figure below.

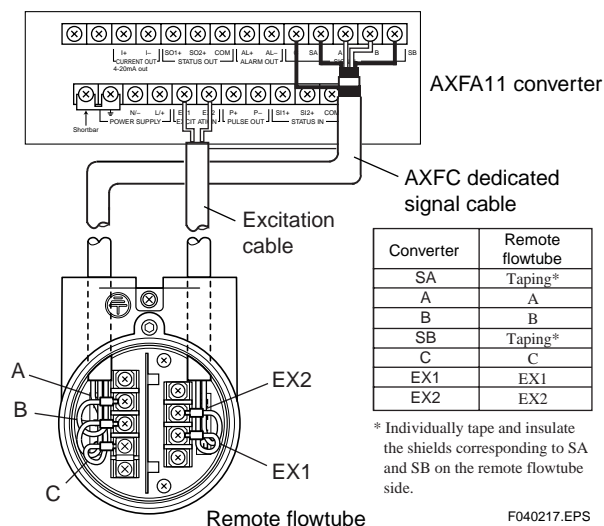

Figure 4.4.7 Wiring Diagram

(4) Connection with the Remote Flowtube (General-Purpose Use, Submersible Type, Size 1100 to 2600 mm (44 to 104 in.))

Connect wiring as shown in the figure below.

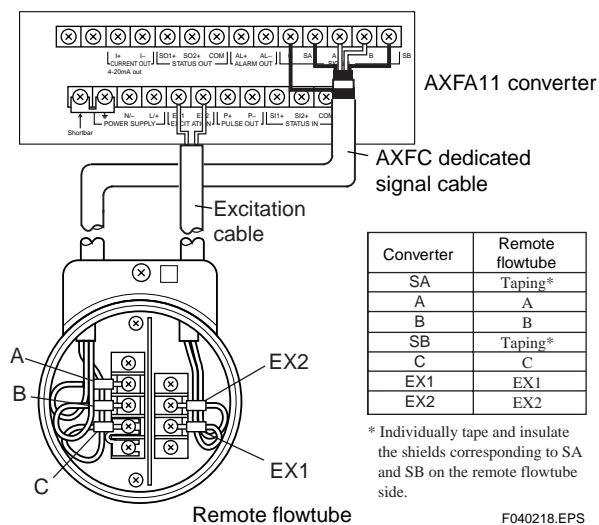

Figure 4.4.8 Wiring Diagram

4.4.7 Connecting to External Instruments

WARNING

Before wiring with external instrument, be sure to turn off the power supply for AXFA11 converter and any external instruments.

Connect the AXFA11 terminal to external instruments, giving attention to the following points.

● 4 to 20 mA DC Current Output

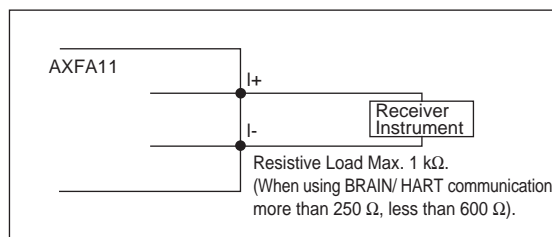

Figure 4.4.9 4 to 20 mA DC Output Connection

● Pulse Output

IMPORTANT

- As this is a transistor contact (insulated type), give attention to proper voltage and polarity when wiring.
- Do not apply a voltage larger than 30V DC or a current larger than 0.2A in order to prevent damage to the instrument.
- When input filter constant of the electronic counter is large in relation to the pulse width, the signal will decrease and the count will not be accurate.
- If the input impedance of the electronic counter is large, an induction noise from the power supply may result in inaccurate counts. Use a shield cable or sufficiently reduce the input impedance of the electronic counter within the electromagnetic flowmeter pulse output specification range.
- The active pulse output (Optional Code EM) cannot be used in conjunction with the standard pulse output.
- When the active pulse output (Optional Code EM) is selected, do not be short-circuit between the P+ and P- terminals to avoid damaging the instrument.
- When the active pulse output (Optional Code EM) is selected, the range of pulse rate must be set to 2 pps maximum.
- To avoid communication (BRAIN/ HART) failure, it is recommended to use the shield cable.

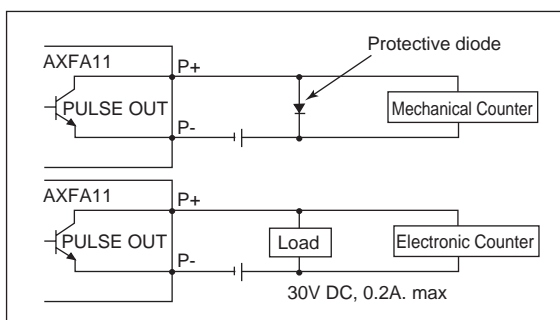

Figure 4.4.10 Pulse Output Connection

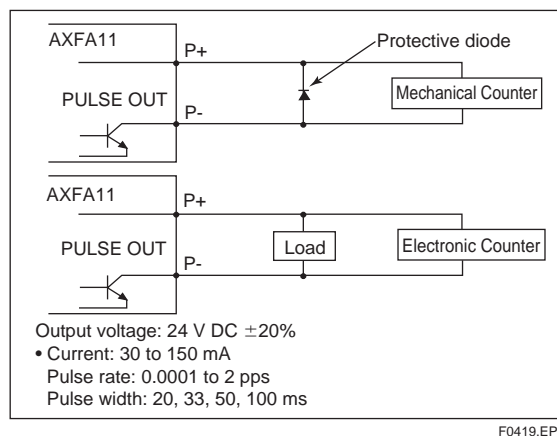

Figure 4.4.11 Active Pulse Output (Optional code EM)

● Status Input

IMPORTANT

Status inputs are designed for use with no-voltage (dry) contacts. Be careful not to connect the status to any signal source carrying voltage. Applying voltage may damage the input circuit.

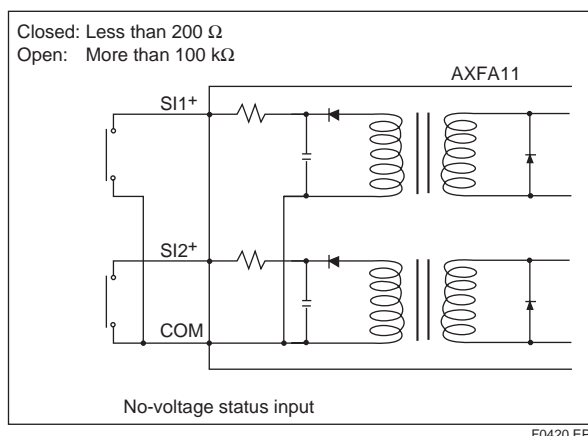

Figure 4.4.12 Status Input Connection

● Status Output / Alarm Output

IMPORTANT

Since this is an isolated transistor output, be careful of voltage and polarity when wiring. Do not apply a voltage larger than 30V DC or a current larger than 0.2A in order to prevent damage to the instrument.

This output cannot switch an AC load. To switch an AC load, an intermediate relay must be inserted as shown in Figure 4.4.13 or Figure 4.4.14.

*The alarm output operates from closed (normal) to open (alarm occurrence) in the default value (as setup upon plant shipment). Changes can be made via the parameter settings.

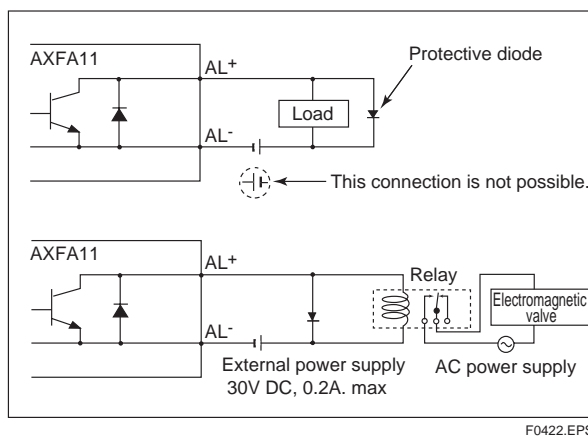
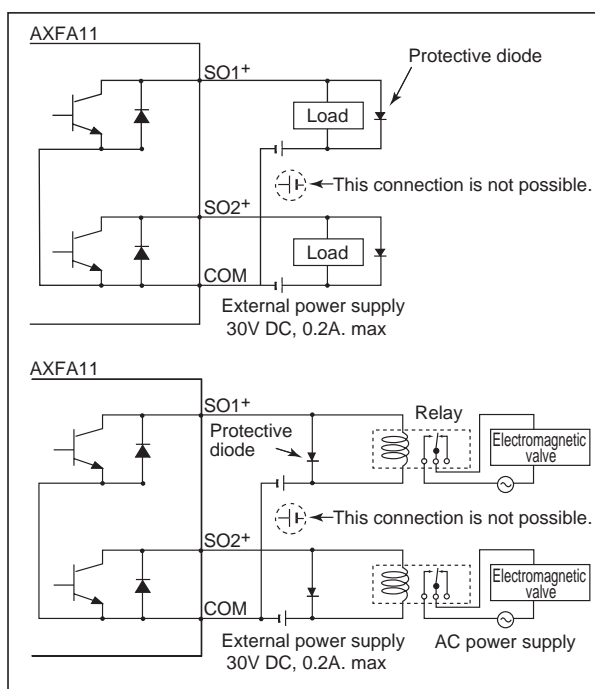





Figure 4.4.14 Alarm Output Connection



F0421.EPS

Figure 4.4.13 Status Output Connection

5. BASIC OPERATING PROCEDURES (USING THE DISPLAY UNIT)

The modification of data settings from the display unit can be carried out using the three setting switches (infrared switches) - namely, the , , and  switches. This chapter will provide a description of basic data configuration and the methods to be used with the three setting switches. The AXFA11 can also be operated using a handheld Brain Terminal (BT200) or a HART Communicator. (Please refer to Chapter 7 for operation via Brain Terminal and Chapter 8 for operation via HART Communicator.)



IMPORTANT

Operate the display unit under the condition where direct sunlight, etc.... do not shine to the setting switches directly when the parameter setting operation is carried out.

Be sure to set parameters as "Protect" on the write protect function after the finish of parameter setting. Refer to the "Menu P: Parameter Protection Items" and section "10.2.2" in detail.



NOTE

- (1) Always use the setting switches with the cover of the AXFA11 closed.
- (2) Use these switches with them covered by the glass window.
- (3) If dirt, dust or other substances surfaces on the display panel glass, wipe them clean with a soft dry cloth.
- (4) The operation with dirty gloves may cause a switch response error.

5.1 Operating Panel Configuration and Functions

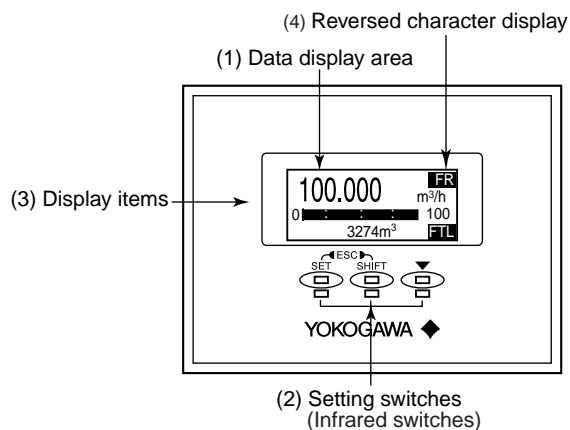



F0501.EPS

(1) Data display area

1st line (Display Select1), 2nd line (Display Select2), and 3rd line (Display Select3) can be displayed using parameter settings. The content corresponding to selected item is shown with the reversed-character on the right of the line.

(2) Setting switch operations

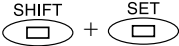
: Move the layer down, select, and confirm

: Move the layer up
(Press the  switch while holding down the  switch)

: Move the cursor down (for selection-type parameters) or increase values (for numeric-type parameters)

: Move the cursor to the right (for numeric-type parameters)

: Move the cursor up (for selection-type parameters)

(3) Display items

Displayed items and reversed-character indication		Content	Disp Select1	Disp Select2 Disp Select3
Instantaneous flow rate: %	FR	Displays the instantaneous flow rate for the span as a percentage.	○	○
Actual instantaneous flow rate	FR	Displays the actual reading for instantaneous flow rate.	○	○
Instantaneous flow rate: mA	FR	Displays the instantaneous flow rate for the span as a current output value.	○	○
Bar graph indicating instantaneous flow rate	None	Displays the instantaneous flow rate for the span as a percentage using bar graph.	×	○
Totalized forward-direction flow rate	FTL	Displays the totalized value for flow rate in the forward direction.	○	○
Totalized reverse-direction flow rate	RTL	Displays the totalized value for flow rate in the reverse direction.	○	○
Totalized differential flow rate	DTL	Displays the differential totalized value for flow rate between forward totalization and reverse totalization.	○	○
Tag number	TAG	Display the tag number (using up to 16 characters).	×	○
Diagnosis of electrode adhesion	ADH	Displays the adhesion condition in the form of a bar graph. (See the description for parameters K10 through K15 from Chapter 6: Parameter Description for more details.)	×	○
Communication	COM	Displays the communication type.	×	○

(4)

T0501.EPS

5. BASIC OPERATING PROCEDURES

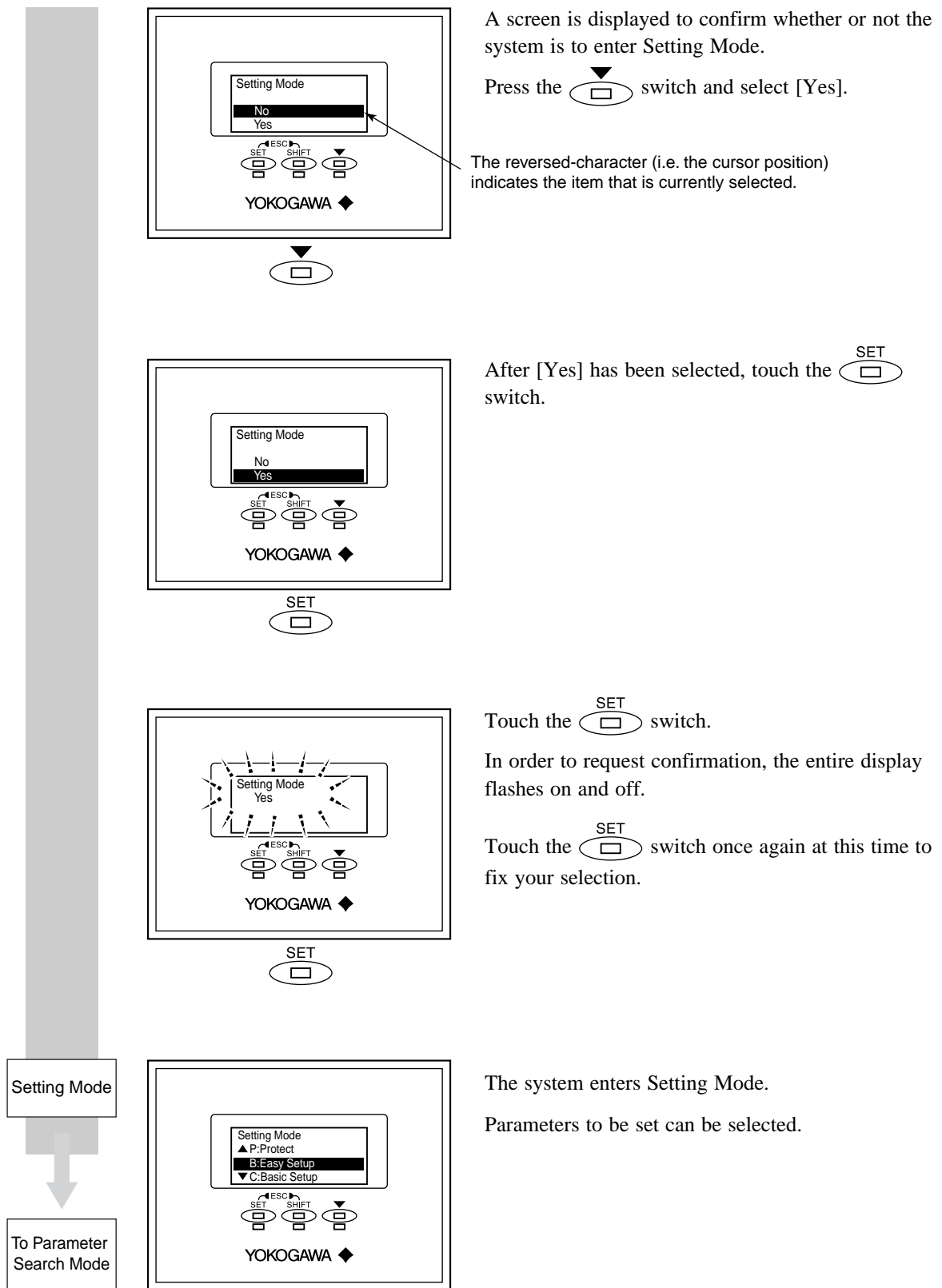

F0503-2.EPS

A screen is displayed to confirm whether or not the system is to enter Setting Mode.

Press the  switch and select [Yes].

The reversed-character (i.e. the cursor position) indicates the item that is currently selected.

After [Yes] has been selected, touch the  switch.

Touch the  switch.

In order to request confirmation, the entire display flashes on and off.

Touch the  switch once again at this time to fix your selection.

The system enters Setting Mode.

Parameters to be set can be selected.

This completes the procedure for changing from the Display Mode to the Parameter Search Mode.

5.2.2 Setting Mode

When the Setting Mode has been activated using the procedure from Section 5.2.1, parameters can be selected for setting.



NOTE

If no operations are carried out for a period of 10 minutes in Setting Mode, the system will automatically return to the Display Mode.

Format for Parameter Data

Depending on the type of parameter, data is formatted in one of the following three ways.

Format	Typical display	Content
(i) Selection-type	B21:Base Flow Unit m ³ ▲m ³ ▼kl(Kiloliter)	The desired data item is selected from a predefined list.
(ii) Numeric-type	B23:Flow Span 100 l/min 000100 l/min Rng:0.00001 → 32000	Data is set using the values in each digit and using the decimal point.
(iii) Alphanumeric-type	C10:Tag No FI-1101 FI-1201	Data is composed using alphanumeric characters (in the case of tag numbers, special units, and the like). With this format, setting can be carried out using up to 16 of the characters shown below.

Regarding the alphanumeric-type format (iii), the following alphanumerics are displayed in the following sequence:

```
#%&*+-. /0123456789:<>A B C D E F G H I J K L M N O P Q R S T U V W X Y Z abcdefghij  
klmnopqrstuvwxyz[space]
```

T0502.EPS

5.3 Parameter Setting Procedure

Once the system is in Setting Mode, the parameters for setting can be selected. On the AXFA11, parameters that are frequently used have been grouped together in Easy Setup in Menu B. This section provides a description of the parameter setting procedure using **B: Easy Setup** and **C: Basic Setup**.

For more details regarding parameter content, please refer to Section 6: Parameter Description.

5.3.1 Setting Example for Selection-Type Data: Flow rate units

This example describes the setting of the flow rate units for the selection-type parameter **B21: Base Flow Unit** from m³ to l (Liter).

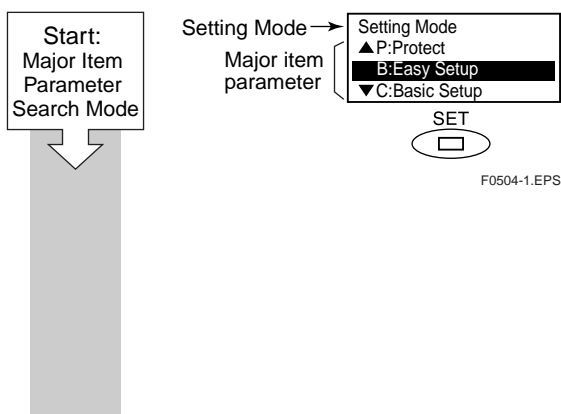

Major Item Parameter Search Mode has been accessed in this screen.

Touch the switch to access **B: Easy Setup**.



NOTE

The ▲ and ▼ symbols to the left of the parameters indicate that additional setting items to those being currently displayed may also be selected. Use the switch to cycle through these items.

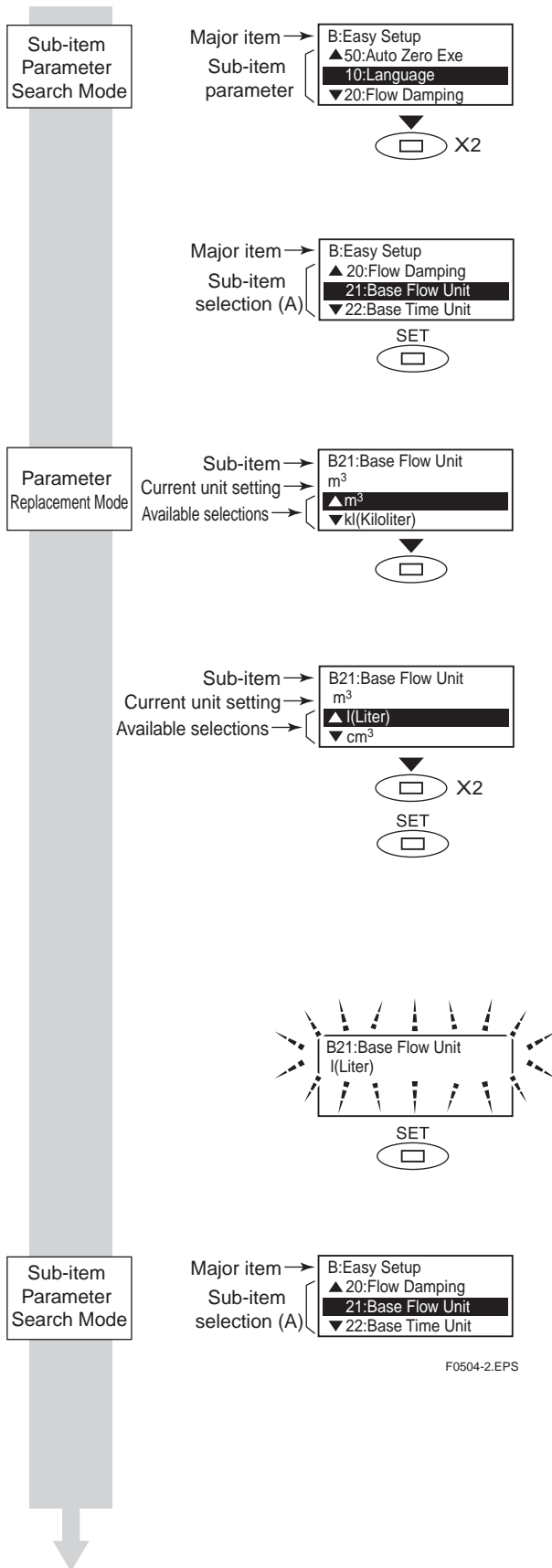

Sub-item Parameter Search Mode has been accessed in this screen.

Touch the switch to move the cursor to **B21: Base Flow Unit**.

The cursor has been moved to **B21: Base Flow Unit** in this screen. (Sub-item selection screen (A))

In this screen, Parameter Replacement Mode has been called up using the switch.

Touch the switch to move the cursor to the unit item for selection. In this example, the switch is touched twice to select l (Liter)

After l (Liter) has been selected, touch the switch.

In order to request confirmation, the entire display flashes on and off.

Touch the switch once again at this time to fix your selection.

The system returns automatically to sub-item selection screen (A).

F0504-2.EPS

5.3.2 Setting Example for Numeric-Type Data: Flow rate span

This example describes the setting of the flow rate span for the numeric-type parameter **B23: Flow Span** from 100 l/min to 120 l/min.

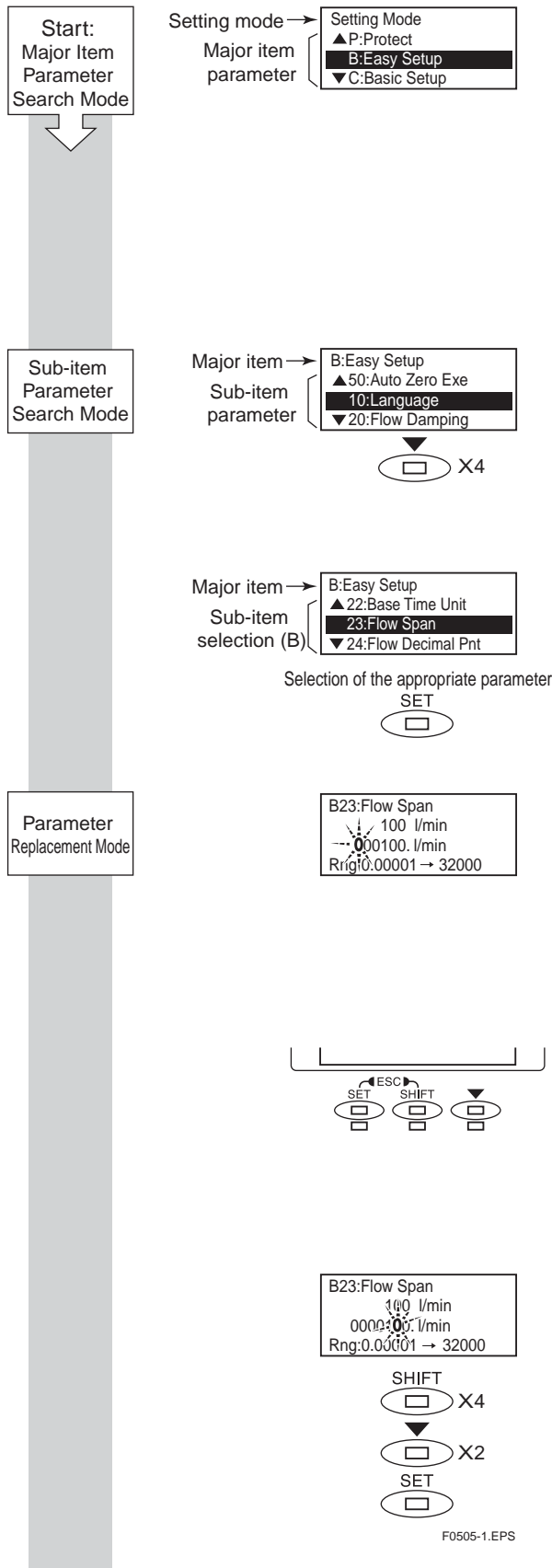

Setting Mode Condition

Touch the switch to access **B: Easy Setup**.



NOTE

The ▲ and ▼ symbols to the left of the parameters indicate that additional setting items to those being currently displayed may also be selected. Use the switch to cycle through these items.

Sub-item Parameter Search Mode has been accessed in this screen.

Touch the switch to move the cursor to **B23: Flow Span**.

The cursor has been moved to **B23: Flow Span** in this screen. (Sub-item selection screen (B))

Touch the switch to access Parameter Replacement Mode.

Once Parameter Replacement Mode has been selected, the digit that can be replaced will be flashed on and off. When in this condition, confirm the relevant setting range as displayed at the bottom of the screen and then set the parameter as required.

In this example, the parameter will be set to “120 l/min”.





NOTE

When setting a new value, use the switch to move from digit to digit, and use the switch to cycle through values for each individual digit. In addition to digit, it is also possible to select a decimal point, and this allows the position of the decimal point to be changed.

Modify the value to “120 l/min” as follows:

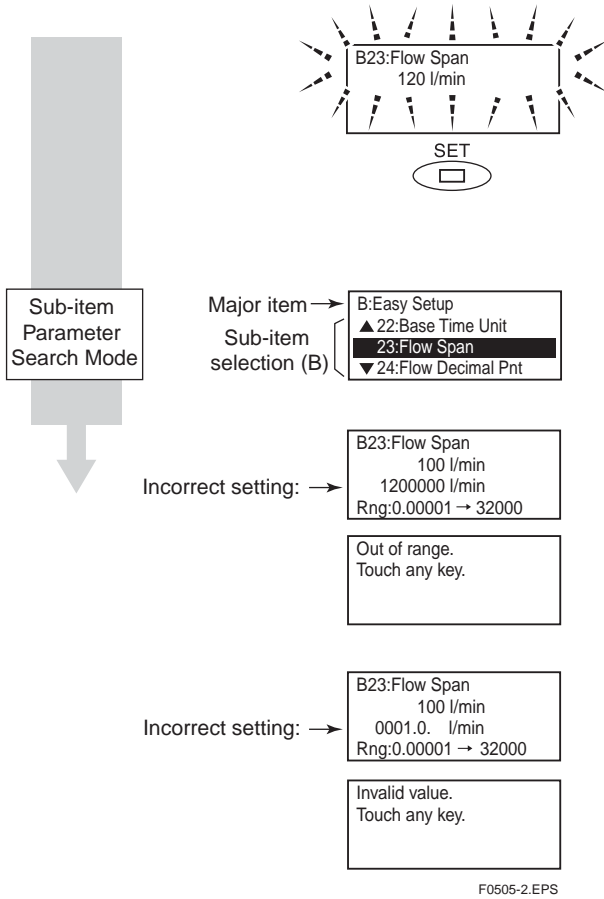
Touch the switch to move the cursor to the position for multiples of 10. Then, touch the switch to change the value at this position from “0” to “2”. When the value of “120” has been setup, touch the switch.



When the  switch is touched, the entire display flashes on and off. Confirm that the setting has been correctly changed to “120”, and then fix this value by touching the  switch once again.

The system returns automatically to sub-item selection screen (B).

 **NOTE**

If the input value is outside the valid selection range, the message “Out of range. Touch any key.” will be displayed. In such a case, touch any switch to return to Parameter Replacement Mode and redo the setting.

 **NOTE**

If more than one decimal point has been input, the message “Invalid value. Touch any key.” will be displayed. In such a case, touch any switch to return to Parameter Replacement Mode and redo the setting.

5.3.3 Setting Example for Alphanumeric-Type Data: Tag number

This example describes the setting of the tag number for the alphanumeric-type parameter **C10: Tag No.** from “FI-1101” to “FI-1201.”

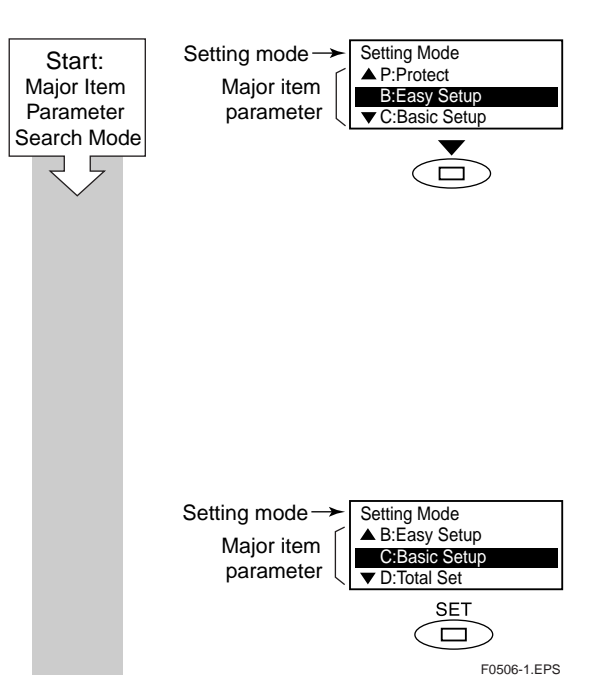

Setting Mode Condition

Touch the  switch to access **C: Basic Setup**.

 **NOTE**

The ▲ and ▼ symbols to the left of the parameters indicate that additional setting items to those being currently displayed may also be selected. Use the  switch to cycle through these items.

The cursor has been moved to **C: Basic Setup** in this screen.

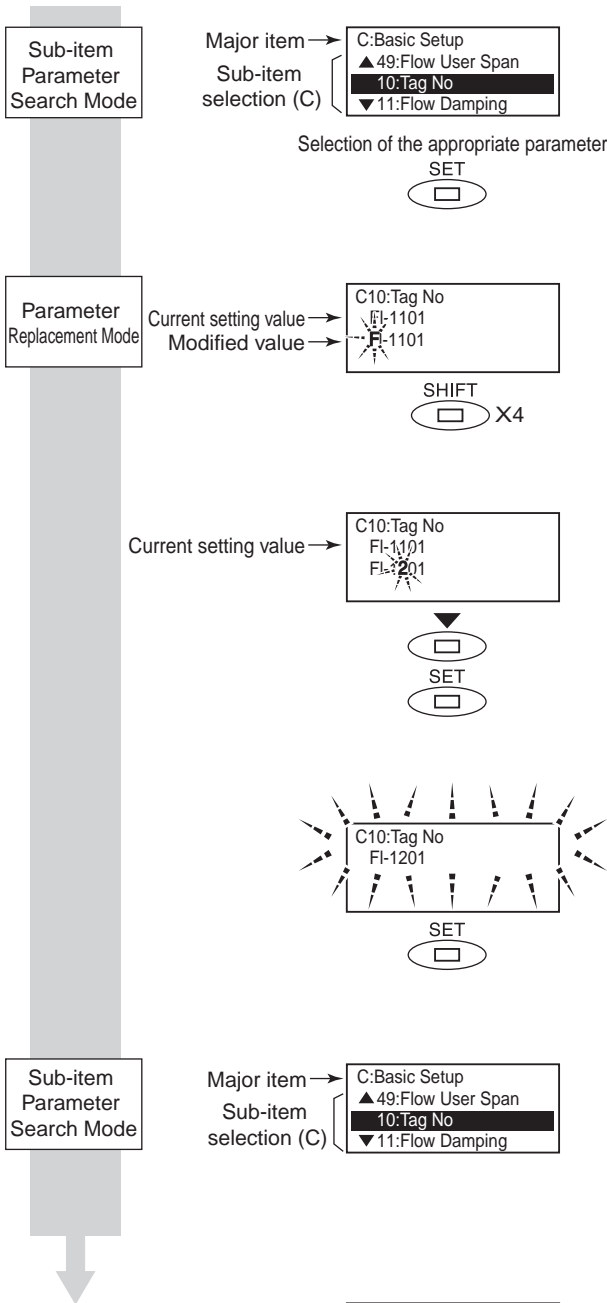

Touch the  switch to enter **C: Basic Setup**.





Upon selection of **C: Basic Setup**, the cursor will be positioned at **C10: Tag No**. (Sub-item selection screen (C))



Touch the  switch to access Parameter Replacement Mode.

The cursor will flash on and off on the left of the tag number. As “FI-1201” is to be setup in this example, touch the  switch to move the cursor to the position for multiples of 100.

At the position for multiples of 100, touch the  switch to change the “1” to “2”. When the setting has been changed to “FI-1201”, touch the  switch.

When the  switch is touched, the entire display flashes on and off. Confirm that the setting has been correctly changed to “FI-1201”, and then fix this setting by touching the  switch once again.

The system returns automatically to sub-item selection screen (C).

After returning to Display Mode by touching using the  and  twice as escape switches, it will be possible to confirm the modified content (if Display Select has been setup to display the tag number.)

Indicates selection of Tag No display for B42: Display Select3.

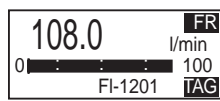

F0506-2.EPS

6. PARAMETER DESCRIPTION

6.1 Parameters

With the exception of parameters that were specified by the customer upon ordering, all of the AXFA11's internal parameters will initially be set to default values. Actions such as the modification of display details can then be carried out whenever necessary.



IMPORTANT

Make sure to keep the AXFA11's power on at least for 30 seconds after you set the parameters. If you turn the power off immediately after the parameters are set, the settings will be canceled.



NOTE

In order to ensure that correct flow rate data can be acquired, it is crucial that the nominal size, flow rate span, and meter factor of the combined remote flowtube are setup. In cases where a remote flowtube is ordered at the same time as the AXFA11, the nominal size and meter factor will be setup upon shipment from the manufacturing plant, and these will not require additional setting. If the AXFA11 is ordered individually, the default value will be setup for the meter factor; accordingly, it will be necessary to change this setting to the meter factor indicated on your remote flowtube data plate.

If a flow rate span is specified upon ordering, this will be set before shipment. If this is not the case, however, it will be necessary for the appropriate value to be set up by the user.

6.2 Parameter Lists

Parameter lists are comprised of the following items.

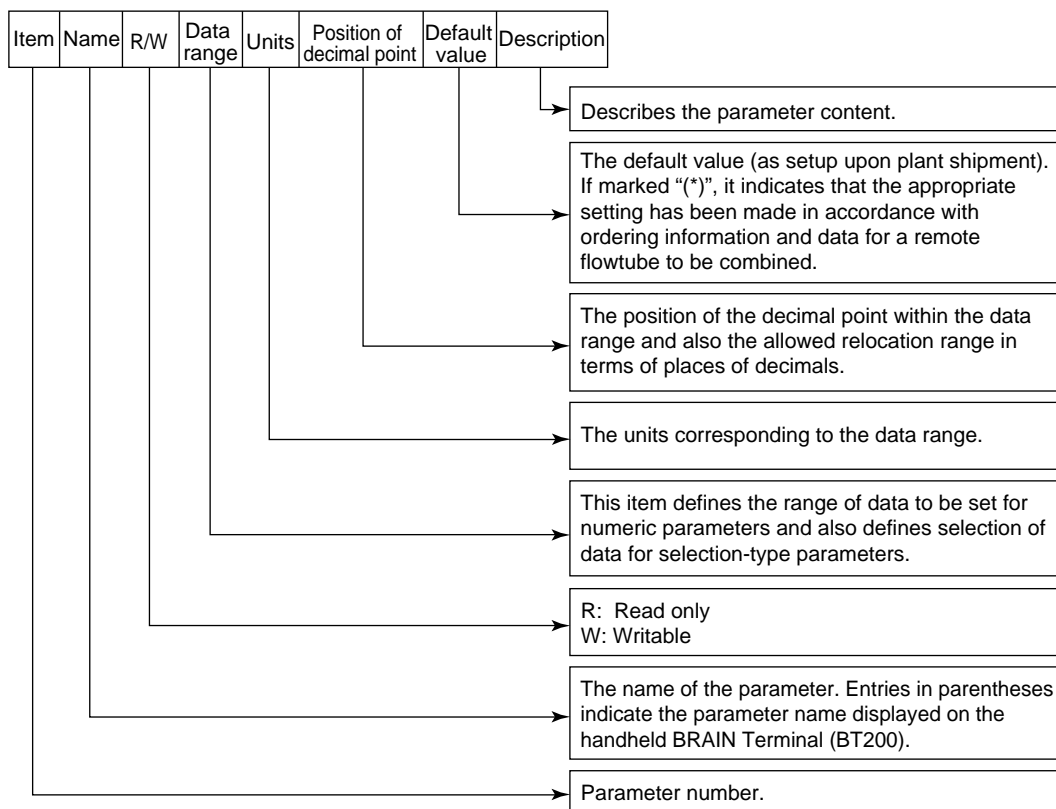

T0601.EPS

6.3 Parameter List Overview

(1) Item A (Menu A): Display items

Menu A contains the instantaneous flow rate, totalization values, and other items relevant to display.

Item	Name	R/W	Data range	Units	Position of decimal point	Default value (*): Indicated item	Description
	Display unit (BRAIN)		Display unit /BRAIN				
A00	Display (DISPLAY)						
A10	FR (FLOW RATE (%))	R	-110.0 to 110.0	%	1		For Display Mode only
A20	FR (FLOW RATE)	R	-999999 to 999999	B21/B22 (C40/C41)	0 to 3		For Display Mode only
A21	FR (FLW RATE (mA))	R	2.400 to 21.600	mA	3		For Display Mode only
A30	FTL (TOTAL)	R	0 to 99999999	B30 (D10)	0 to 7		For Display Mode only
A31	RTL (REV TOTAL)	R	0 to 99999999	B30 (D10)	0 to 7		For Display Mode only
A32	DTL (DIF TOTAL)	R	-99999999 to 99999999	B30 (D10)	0 to 7		For Display Mode only
A60	— (SELF CHECK)	R	Good Error				See “6.5 Alarm Functions”.

T0602.EPS

(2) Item B (Menu B): Easy Setup items

Those parameters with a high frequency of use have been grouped together in Menu B. All basic functions can be controlled using only the parameters from this block.

Item	Name	R/W	Data range	Units	Position of decimal point	Default value (*): Indicated item	Description
	Display unit (BRAIN)		Display unit /BRAIN				
B00	Easy Setup (EASY SETUP)						
B10	Language (LANGUAGE)	W	English Japanese French German Italian Spanish			English	Selects the language used for the display unit. Linked with H30.
B20	Flow Damping (FLOW DAMPING)	W	0.1 to 200.0	s	1	3.0 s	Sets damping time. Linked with C11.
B21	Base Flow Unit (FLOW UNIT)	W	Ml (Megaliter) m ³ kl (Kiloliter) l (Liter) cm ³ m t kg g kcf cf mcf Mgal (US) kgal (US) gal (US) mgal (US) kbbbl (US Oil) bbbl (US Oil) mdbl (US Oil) ubbl (US Oil) kbbbl (US Beer) bbbl (US Beer) mdbl (US Beer) ubbl (US Beer) ft klb (US) lb (US)			m (*)	Selects flow units for the flow rate span. Linked with C40.

T0603-1.EPS

6. PARAMETER DESCRIPTION

Item	Name	R/W	Data range	Units	Position of decimal point	Default value (*): Indicated item	Description
	Display unit (BRAIN)		Display unit /BRAIN				
B22	Base Time Unit (TIME UNIT)	W	/d /h /min /s			/s (*)	Selects time units for the flow rate span. Linked with C41.
B23	Flow Span (FLOW SPAN)	W	0.0001 to 32000	B21 /B22 (C40/C41)	0 to 4	1 m/s (*)	Sets flow rate span (with units from B21 and B22). Linked with C42.
B24	Flow Decimal Pnt (FLOW DECIMAL)	W	Auto 0 1 2 3			Auto (*)	Selects decimal point position for the display unit's instantaneous flow rate. Linked with C43.
B30	Total Unit (TOTAL UNIT)	W	n Unit/P u Unit/P m Unit/P Unit/P k Unit/P M Unit/P Pulse/s			Pulse/s (*)	Selects the flow rate unit per one pulse as used for totalization display. Linked with D10.
B31	Total Scale (TOTAL SCALE)	W	0 to 32000	B30 (D10)	0 to 4	0 (*)	Sets the flow rate per one pulse for the totalization display. Linked with D11.
B32	Pulse Unit (PULSE UNIT)	W	n Unit/P u Unit/P m Unit/P Unit/P k Unit/P M Unit/P Pulse/s			Pulse/s (*)	Selects the flow rate unit per one pulse as used for pulse output. Linked with E10.
B33	Pulse Scale (PULSE SCALE)	W	0 to 32000	B32 (E10)	0 to 4	0 (*)	Sets the flow rate per one pulse as used for pulse output. Linked with E11.
B40	Display Select1 (DISP SELECT1)	W	Flow Rate(%) Flow Rate Flow Rate(mA) Forward Total Reverse Total Dif Total			Flow Rate	Selects content of the first line for Display Mode. Linked with H10.
B41	Display Select2 (DISP SELECT2)	W	Off Flow Rate(%) Flow Rate Flow Rate(mA) Flow Rate(Bar) Forward Total Reverse Total Dif Total Tag No Adhesion Check Communication			Off	Selects content of the second line for Display Mode. Linked with H11.
B42	Display Select3 (DISP SELECT3)	W	ame as B41 (Display Select2)			Off	Selects content of the third line for Display Mode. Linked with H12.
B50	Auto Zero Exe (AUTOZERO EXE)	W	No Execution Execution			No Execution	Selects whether or not automatic zero adjustment is carried out. Linked with M10.
B60	— (SELF CHECK)	R	Good Error				See “6.5 Alarm Functions”.

T0603-2.EPS

(3) Item C (Menu C): Basic Setting items

Menu C principally contains the basic setting items for the flowtube.

Item	Name	R/W	Data range	Units	Position of decimal point	Default value (*): Indicated item	Description
	Display unit (BRAIN)		Display unit /BRAIN				
C00	Basic Setup (BASIC SETUP)						
C10	Tag No (TAG NO)	W	ASCII 16 characters				Sets Tag number up to 16 characters.
C11	Flow Damping (FLOW DAMPING)	W	0.1 to 200.0	s	1	3.0 s	Sets damping time. Linked with B20.
C20	Measure Mode (MEASURE MODE)	W	Standard DF Enhanced DF			Standard DF	Selects measurement mode for dual frequency excitation
C21	Low MF (LOW MF)	W	0.0100 to 3.0000		4	1.0000 (*)	Sets low-frequency meter factor for standard dual frequency excitation
C22	High MF (HIGH MF)	W	0.0100 to 3.0000		4	1.0000 (*)	Sets high-frequency meter factor for standard dual frequency excitation
C23	Low MF(EDF) (LOW MF(EDF))	W	0.0000 to 3.0000		4	1.0000 (*)	Sets low-frequency meter factor for enhanced dual frequency excitation
C24	High MF(EDF) (HIGH MF(EDF))	W	0.0000 to 3.0000		4	1.0000 (*)	Sets high-frequency meter factor for enhanced dual frequency excitation
C30	Select Flow Tube (FLOW TUBE)	W	ADMAG AXF ADMAG ADMAG AE ADMAG SE YEW MAG Calibrator Other			ADMAG AXF	Selects the flowtube's model name.
C31	Nominal Size Unit (SIZE UNIT)	W	mm inch			mm inch	Selects the nominal size units for the flowtube.
C32	Nominal Size (NOMINAL SIZE)	W	0.99 to 3000.1 0.01 to 120.1	mm inch	0 to 2	100 (*)	Sets flowtube nominal size in selected unit at C31.
C40	Base Flow Unit (FLOW UNIT)	W	Ml(Megaliter) m ³ kl(Kiloliter) l(Liter) cm ³ m t kg g kcf cf mcf Mgal (US) kgal (US) gal (US) mgal (US) kbbbl (US Oil) bbbl (US Oil) mbbl (US Oil) ubbl (US Oil) kbbbl (US Beer) bbbl (US Beer) mbbl (US Beer) ubbl (US Beer) ft klb (US) lb (US)			m (*)	Selects flow units for the flow rate span. Linked with B21.
C41	Base Time Unit (TIME UNIT)	W	/d /h /min /s			/s (*)	Selects time units for the flow rate span. Linked with B22.
C42	Flow Span (FLOW SPAN)	W	0.0001 to 32000	C40/C41 (B21 /B22)	0 to 4	1 m/s (*)	Sets flow rate span (with units from C40 and C41). Linked with B23.
C43	Flow Decimal Pnt (FLOW DECIMAL)	W	Auto 0 1 2 3			Auto (*)	Selects decimal point position for the display unit's instantaneous flow rate. Linked with B24.

6. PARAMETER DESCRIPTION

Item	Name	R/W	Data range	Units	Position of decimal point	Default value (*): Indicated item	Description
	Display unit (BRAIN)		Display unit /BRAIN				
C44	Velocity Check (VELOCITY CHK)	R	0.000 to 99.999	m/s	3		Display of the span setting using flow velocity (m/s).
C45	Density Unit (DENSITY UNIT)	W	kg/m ³ lb/gal lb/cf			kg/m ³	Sets units for density when mass flow rate is selected.
C46	Mass Flow Density (MASS DENSITY)	W	0 to 32000	C45	0 to 4	0	Sets density when mass flow rate is selected (with units from C45).
C47	User Span Select (USER SPN SEL)	W	No Yes			No	Selects whether or not special units are used for flow rate units.
C48	Flow User Unit (FL USER UNIT)	W	8 alphanumeric characters				Sets the special flow rate units.
C49	Flow User Span (FL USER SPAN)	W	0.0001 to 32000	C48	0 to 4	100	Sets span when using special flow rate units.
C60	— (SELF CHECK)	R	Good Error				See “6.5 Alarm Functions”.

T0604-2.EPS

(4) Item D (Menu D): Total Setting items

Menu D contains setting items such as the totalization scale and the forward/reverse totalized values.

Item	Name	R/W	Data range	Units	Position of decimal point	Default value (*): Indicated item	Description
	Display unit (BRAIN)		Display unit /BRAIN				
D00	Total Set (TOTAL SET)						
D10	Total Unit (TOTAL UNIT)	W	n Unit/P u Unit/P m Unit/P Unit/P k Unit/P M Unit/P Pulse/s			Pulse/s (*)	Selects the flow rate unit per one pulse as used for totalization display. Linked with B30.
D11	Total Scale (TOTAL SCALE)	W	0 to 32000	D10 (B30)	0 to 4	0 (*)	Sets the flow rate per one pulse for the totalization display. Linked with B31.
D12	Total Decimal Pnt (TL DECIMAL)	W	0 1 2 3 4 5 6 7			0	Selects position of decimal point for totalization display
D13	Total Low Cut (TOTAL LOWCUT)	W	0 to 100	%	0	3 %	Sets the range in vicinity of 0% within which the totalization display will be halted.
D20	Total Execution (TOTAL EXEC)	W	Start Stop Preset Total Preset Rev Total			Start	Executes “Start” or “Stop” of the totalization function, or executes “Preset Total” or “Preset Rev Total”.
D21	Ttl Set Val Lower (TL SET VAL L)	W	0 to 999999		0	0	Sets the totalization preset value in the lower 6 digits of the 8-digit totalized value.
D22	Ttl Set Val Upper (TL SET VAL U)	W	0 to 99		0	0	Sets the totalization preset value in the upper 2 digits of the 8-digit totalized value.
D23	Ttl Switch Lower (TL SWITCH LO)	W	0 to 999999		0	0	Sets the totalization switch value in the lower 6 digits of the 8-digit totalized value.
D24	Ttl Switch Upper (TL SWITCH UP)	W	0 to 99		0	0	Sets the totalization switch value in the upper 2 digits of the 8-digits totalized value.
D30	Ttl User Select (TL USER SEL)	W	No Yes			No	Selects whether or not special units are used as totalized units.
D31	Ttl User Unit (TL USER UNIT)	W	8 alphanumeric characters				Sets the special totalized units.
D60	— (SELF CHECK)	R	Good Error				See “6.5 Alarm Functions”.

T0605.EPS

(5) Item E (Menu E): Pulse Setting items

Menu E contains items relevant to pulse output. This is used to set parameters such as the pulse scale and width.

Item	Name	R/W	Data range	Units	Position of decimal point	Default value (*): Indicated item	Description
	Display unit (BRAIN)		Display unit /BRAIN				
E00	Pulse Set (PULSE SET)						
E10	Pulse Unit (PULSE UNIT)	W	n Unit/P u Unit/P m Unit/P Unit/P k Unit/P M Unit/P Pulse/s			Pulse/s (*)	Selects the flow rate unit per one pulse as used for pulse output. Linked with B32.
E11	Pulse Scale (PULSE SCALE)	W	0 to 32000	E10 (B32)	0 to 4	0 (*)	Sets the flow rate per one pulse as used for pulse output. Linked with B33.
E12	Pulse Width (PULSE WIDTH)	W	50% Duty 0.05 ms 0.1 ms 0.5 ms 1 ms 20 ms 33 ms 50 ms 100 ms			50% Duty	Selects the pulse width for pulse output.
E13	Pulse Low Cut (PULSE LOWCUT)	W	0 to 100	%	0	3 %	Sets the range in vicinity of 0% within which pulse output will be halted.
E20	Pulse Active Mode (PLS ACT MODE)	W	Closed(On) Act Open(Off) Act			Closed(On) Act	Selects whether pulse output will be set to "On Active" or "Off Active."
E60	— (SELF CHECK)	R	Good Error				See "6.5 Alarm Function".

T0606.EPS

(6) Item F (Menu F): Status Functions Setting items

Menu F contains items relevant to multiplex range output and other status Input/Output.

Item	Name	R/W	Data range	Units	Position of decimal point	Default value (*): Indicated item	Description
	Display unit (BRAIN)		Display unit /BRAIN				
F00	Status Function (STATUS FUNC)						
F10	SO1 Function (SO1 FUNCTION)	W	No Function Warning Output Total Switch H/L Alarm HH/LL Alarm Fwd/Rev Ranges Auto 2 Ranges Auto 3 Ranges Auto 4 Ranges Ext 2 Answer Ext 3 Answer Ext 4 Answer			No Function	Selects function for the SO1 terminal
F10	SO2 Function (SO2 FUNCTION)	W	No Function Warning Output Total Switch H/L Alarm HH/LL Alarm Fwd/Rev Ranges Auto 2 Ranges Auto 3 Ranges Auto 4 Ranges Ext 2 Answer Ext 3 Answer Ext 4 Answer			No Function	Selects function for the SO2 terminal

T0607-1.EPS

6. PARAMETER DESCRIPTION

Item	Name	R/W	Data range	Units	Position of decimal point	Default value (*): Indicated item	Description
	Display unit (BRAIN)		Display unit /BRAIN				
F12	SI1 Function (SI1 FUNCTION)	W	No Function 0% Singal Lock Ext Auto Zero Ext Ttl Preset Ext Rev Ttl Set Ext 2 Ranges Ext 3 Ranges Ext 4 Ranges			No Function	Selects function for the SI1 terminal
F13	SI2 Function (SI2 FUNCTION)	W	No Function 0% Singal Lock Ext Auto Zero Ext Ttl Preset Ext Rev Ttl Set Ext 2 Ranges Ext 3 Ranges Ext 4 Ranges			No Function	Selects function for the SI2 terminal
F14	SO1/2 Active Mode (SO ACT MODE)	W	Closed(On) Act Open(Off) Act			Closed(On) Act	Selects whether SO1/SO2 output will be set to "On Active" or "Off Active."
F15	SI1/2 Active Mode (SI ACT MODE)	W	Short Active Open Active			Short Active	Selects whether SI1/SI2 input will be set to "Short Active" or "Open Active."
F30	Forward Span2 (FWD SPAN2)	W	0.0001 to 32000	C40 /C41	0 to 4	1	Sets flow rate span for forward No. 2 range
F31	Forward Span3 (FWD SPAN3)	W	0.0001 to 32000	C40 /C41	0 to 4	1	Sets flow rate span for forward No. 3 range
F32	Forward Span4 (FWD SPAN4)	W	0.0001 to 32000	C40 /C41	0 to 4	1	Sets flow rate span for forward No. 4 range
F33	Reverse Span1 (REV SPAN1)	W	0.0001 to 32000	C40 /C41	0 to 4	1	Sets flow rate span for reverse No. 1 range
F34	Reverse Span2 (REV SPAN2)	W	0.0001 to 32000	C40 /C41	0 to 4	1	Sets flow rate span for reverse No. 2 range
F35	Reverse Span3 (REV SPAN3)	W	0.0001 to 32000	C40 /C41	0 to 4	1	Sets flow rate span for reverse No. 3 range
F36	Reverse Span4 (REV SPAN4)	W	0.0001 to 32000	C40 /C41	0 to 4	1	Sets flow rate span for reverse No. 4 range
F40	Auto Range Hys (AUTO RNG HYS)	W	0 to 15	%	0	10 %	Sets hysteresis width for automatic range switching
F41	Bi Direction Hys (BI DIREC HYS)	W	0 to 8	%	0	2 %	Sets hysteresis width for forward/reverse switching
F60	— (SELF CHECK)	R	Good Error				See "6.5 Alarm Function".

T0607-2.EPS

(7) Item G (Menu G): Alarm Setting items

Menu G contains setting items relevant to alarm output, burnout, alarm record, etc.

Item	Name	R/W	Data range	Units	Position of decimal point	Default value (*): Indicated item	Description
	Display unit (BRAIN)		Display unit /BRAIN				
G00	Alarm (ALARM)						
G10	Low Alarm (LOW ALARM)	W	-110 to 110	%	0	-110	Sets level setting value for low flow rate limit (L)
G11	High Alarm (HIGH ALARM)	W	-110 to 110	%	0	110	Sets level setting value for high flow rate limit (H)
G12	Low Low Alarm (LO LO ALARM)	W	-110 to 110	%	0	-110	Sets level setting value for low-low flow rate limit (LL)
G13	High High Alarm (HI HI ALARM)	W	-110 to 110	%	0	110	Sets level setting value for high-high flow rate limit (HH)

T0608-1.EPS

6. PARAMETER DESCRIPTION

Item	Name	R/W	Data range	Units	Position of decimal point	Default value (*): Indicated item	Description
	Display unit (BRAIN)		Display unit /BRAIN				
G14	H/L Alarm Hys (H/L ALM HYS)	W	0 to 10	%	0	5 %	Sets hysteresis width for high-low flow rate limit alarm
G20	Alm Out Act Mode (ALM OUT ACT)	W	Closed(On) Act Open(Off) Act			Open(Off) Act	Selects whether alarm output will be set to "On Active" or "Off Active."
G21	4-20mA Alarm Out (4-20 ALM OUT)	W	2.4mA or Less 4.0mA Hold 21.6mA or More			21.6mA or More	Selects the current output during alarm occurrence.
G22	4-20mA Burn Out (4-20 BURNOUT)	R	High Low			—	Displays the current output during a CPU failure.
G30	Alm-Setting (ALM-SETTING)	W	No Yes			Yes	Selects whether a setting alarm is to be specified as an alarm.
G31	Alm-Sig Over (ALM-SIG OVER)	W	No Yes			Yes	Selects whether a signal overflow alarm is to be specified as an alarm.
G32	Alm-Emp Pipe (ALM-EMP PIPE)	W	No Yes			Yes	Selects whether an empty pipe alarm is to be specified as an alarm.
G33	Alm-HH/LL (ALM-HH/LL)	W	No Yes			No	Selects whether a flow rate high-high or low-low alarm is to be specified as an alarm.
G34	Alm-Adhesion (ALM-ADHESION)	W	No Yes			No	Selects whether an electrode adhesion alarm is to be specified as an alarm.
G40	Operation Time (OPERATE TIME)	R	0D 00:00 to 99999D 23:59				Operation time
G41	Alm Record1 (ALM RECORD1)	R	10:uP Fault 11:EEPROM Fault 12:A/D(H) Fault 13:A/D(L) Fault 14:A/D(Z) Fault 15:Coil Open 16:EEPROM Dflt 18:Power Off 19:Inst Pwr Fail 28:WDT 30:Sig Overflow 31:Empty Pipe 33:Adhesion Alm				Displays the content of the most recent alarm.
G42	Alm Record Time1 (ALM TIME 1)	R	0D 00:00 to 99999D 23:59				Displays the operation time at the occurrence of the most recent alarm.
G43	Alm Record2 (ALM RECORD2)	R	See G41				Displays the content of the second most recent alarm.
G44	Alm Record Time2 (ALM TIME 2)	R	0D 00:00 to 99999D 23:59				Displays the operation time at occurrence of the second most recent alarm.
G45	Alm Record3 (ALM RECORD3)	R	See G41				Displays the content of the third most recent alarm.
G46	Alm Record Time3 (ALM TIME 3)	R	0D 00:00 to 99999D 23:59				Displays the operation time at the occurrence of the third most recent alarm.
G47	Alm Record4 (ALM RECORD4)	R	See G41				Displays the content of the fourth most recent alarm.
G48	Alm Record Time4 (ALM TIME 4)	R	0D 00:00 to 99999D 23:59				Displays the operation time at the occurrence of the fourth most recent alarm.
G60	— (SELF CHECK)	R	Good Error				See "6.5 Alarm Functions".

T0608-2.EPS

(8) Item H (Menu H): Display Setting items

Menu H contains setting items that are relevant to display on the display unit.

Item	Name	R/W	Data range	Units	Position of decimal point	Default value (*): Indicated item	Description
	Display unit (BRAIN)		Display unit /BRAIN				
H00	Display Set (DISP SET)						
H10	Display Select1 (DISP SELECT1)	W	Flow Rate(%) Flow Rate Flow Rate(mA) Forward Total Reverse Total Dif Total			Flow Rate	Selects content of the first line for Display Mode. Linked with B40.
H11	Display Select2 (DISP SELECT2)	W	Off Flow Rate(%) Flow Rate Flow Rate(mA) Flow Rate(Bar) Forward Total Reverse Total Dif Total Tag No Adhesion Check Communication			Off	Selects content of the second line for Display Mode. Linked with B41.
H12	Display Select3 (DISP SELECT3)	W	ame as H11 (Display Select2)			Off	Selects content of the third line for Display Mode. Linked with B42.
H20	Display Cycle (DISP CYCLE)	W	200ms 400ms 1s 2s 4s 8s			400ms	Selects the display cycle.
H20	Language (LANGUAGE)	W	English Japanese French German Italian Spanish			English	Selects the language used by the display unit. Linked with B10.
H60	— (SELF CHECK)	R	Good Error				See “6.5 Alarm Functions”.

T0609.EPS

(9) Item J (Menu J): Auxiliary Function Setting items

Menu J contains setting items such as the flow direction, rate limits, and low cut.

Item	Name	R/W	Data range	Units	Position of decimal point	Default value (*): Indicated item	Description
	Display unit (BRAIN)		Display unit /BRAIN				
J00	Aux (AUX)						
J10	4-20mA Low Cut (4-20 LOW CUT)	W	0 to 10	%	0	0%	Sets the range in vicinity of 0% within which the current output will be 4 mA
J11	4-20mA Low Lmt (4-20 LOW LMT)	W	-20.0 to 100.0	%	1	-20.0%	Sets the low limit for current output
J12	4-20mA High Lmt (4-20 HI LMT)	W	0.0 to 120.0	%	1	120.0%	Sets the high limit for current output
J20	Flow Direction (FLOW DIRECT)	W	Forward Reverse			Forward	Selects the flow direction.
J21	Rate Limit (RATE LIMIT)	W	0 to 10	%	0	5%	Sets the level to reduce output fluctuation.
J22	Dead Time (DEAD TIME)	W	0 to 15	s	0	0s	Sets the dead time to reduce output fluctuation. When “0” is set, rate limit function is not available.
J23	Pulsing Flow (PULSING FLOW)	W	No Yes			No	Selects whether pulsing flow is to be supported.
J24	T/P Damp Select (T/P DAMP SEL)	W	Damping No Damping			Damping	Selects whether the flow rate value obtained through damping calculation for total/pulse or the instantaneous flow rate value (no damping) for total/pulse is to be used.

T0610-1.EPS

6. PARAMETER DESCRIPTION

Item	Name	R/W	Data range	Units	Position of decimal point	Default value (*): Indicated item	Description
	Display unit (BRAIN)		Display unit /BRAIN				
J30	Power Synch (POWER SYNCH)	W	No Yes			Yes	Selects whether or not the internal frequency is to be synchronized with the power supply frequency.
J31	Power Frequency (POWER FREQ)	R/W	47.00 to 63.00	Hz	2	50.00	Displays the power-supply frequency (for Power Synch = "Yes"), or sets the power-supply frequency (for Power Synch="No").
J40	Memo 1 (MEMO 1)	W	ASCII 16 characters				Memo field
J41	Memo 2 (MEMO 2)	W	ASCII 16 characters				Memo field
J42	Memo 3 (MEMO 3)	W	ASCII 16 characters				Memo field
J50	Software Rev No (SOFTWARE REV)	R	—				Software revision number
J60	— (SELF CHECK)	R	Good Error				See "6.5 Alarm Functions".

T0610-2.EPS

(10) Item K (Menu K): Diagnostic Function Setting items

Menu K contains items that are relevant to the diagnosis of insulation adhesion to the electrode.

Item	Name	R/W	Data range	Units	Position of decimal point	Default value (*): Indicated item	Description
	Display unit (BRAIN)		Display unit /BRAIN				
K00	Diagnosis (DIAGNOSIS)						
K10	Adhesion Check (ADHESION CHK)	W	No Yes			No	Selects whether or not to perform diagnosis of adhesion to the electrode.
K11	Adhesion Level1 (ADH LEVEL1)	W	0.00 to 100.00	M ohm	2	0.10	Sets the resistance value for adhesion Level 1 to the electrode.
K12	Adhesion Level2 (ADH LEVEL2)	W	0.00 to 100.00	M ohm	2	0.50	Sets the resistance value for adhesion Level 2 to the electrode.
K13	Adhesion Level3 (ADH LEVEL3)	W	0.00 to 100.00	M ohm	2	1.00	Sets the resistance value for adhesion Level 3 to the electrode.
K14	Adhesion Level4 (ADH LEVEL4)	W	0.00 to 100.00	M ohm	2	3.00	Sets the resistance value for adhesion Level 4 to the electrode.
K15	Adh Measure Value (ADH MEAS VAL)	R	—	M ohm	2		Displays the resistance value for adhesion to the electrode.
K60	— (SELF CHECK)	R	Good Error				See "6.5 Alarm Functions".

T0611.EPS

(11) Item M (Menu M): Automatic Zero-Adjustment Function Setting items

Menu M contains items that are relevant to automatic zero adjustment.

Item	Name	R/W	Data range	Units	Position of decimal point	Default value (*): Indicated item	Description
	Display unit (BRAIN)		Display unit /BRAIN				
M00	Adjustment (ADJUSTMENT)						
M10	Auto Zero Exe (AUTOZERO EXE)	W	No Execution Execution			No Execution	Selects whether or not automatic zero adjustment is carried out. Linked with B50.
M11	Magflow Zero (MAGFLOW ZERO)	R/W	-99.999 to 99.999		3	0.000	Displays the result of the automatic zero adjustment, or sets the zero point.
M60	— (SELF CHECK)	R	Good Error				See "6.5 Alarm Functions".

T0612.EPS

(12) Item N (Menu N): Loop Test Setting items

Menu N contains items that are relevant to the execution of loop testing.

Item	Name	R/W	Data range	Units	Position of decimal point	Default value (*): Indicated item	Description
	Display unit (BRAIN)		Display unit /BRAIN				
N00	Test (TEST)						
N10	Test Mode (TEST MODE)	W	Normal Test			Normal	Selects whether mode will be set to "Normal" or "Test".
N11	Test Output Value (TEST OUT VAL)	W	-10 to 110	%	0	0%	Sets the test output value.
N20	Test SO1 (TEST SO1)	W	Open(Off) Closed(On)			Open(Off)	Selects the test condition for SO1 terminal.
N21	Test SO2 (TEST SO2)	W	Open(Off) Closed(On)			Open(Off)	Selects the test condition for SO2 terminal.
N22	Test Alarm Out (TEST ALM OUT)	W	Open(Off) Closed(On)			Closed(On)	Selects the test condition for alarm output terminal.
N23	Test SI1 (TEST SI1)	R	Open Short				Displays the test condition for SI1 terminal.
N24	Test SI2 (TEST SI2)	R	Open Short				Displays the test condition for SI2 terminal.
N60	— (SELF CHECK)	R	Good Error				See "6.5 Alarm Functions".

T0613.EPS

(13) Item P (Menu P): Parameter Protection items

Menu P contains items that are relevant to write protection and passwords.

Item	Name	R/W	Data range	Units	Position of decimal point	Default value (*): Indicated item	Description
	Display unit (BRAIN)		Display unit /BRAIN				
P00	Protect (PROTECT)						
P10	Key Code (KEY CODE)	W	0 to 9999			0	Parameter of the display restriction
P20	Write Protect (W PROTECT)	R	No Yes			No	Displays whether or not overwriting of parameter data is prohibited.
P21	Enable Wrt Passwd (ENABLE WRITE)	W	ASCII 8 characters				Sets the correct password so that write protection function will be released.
P22	New Password (NEW PASSWORD)	W	ASCII 8 characters				Sets the password for write protection function
P23	Software Seal (SOFT SEAL)	R	Break Keep				Displays whether or not a Joker password was used (Break).
P60	— (SELF CHECK)	R	Good Error				See "6.5 Alarm Functions".

T0613-1.EPS

6.4 Parameter Description

(1) Menu B: Easy Setup items

Those parameters with a high frequency of use have been grouped together in Easy Setup. All basic functions can be controlled using only the parameters from this block. Parameters from Menu B share identical names with those from other menus; however, modification of one such parameter will result in the other being automatically modified.

[B10: Language] Selection of language used for the display unit

→ This setting is linked with that of parameter **H30**. One of the following languages can be selected for the display unit.

Data Range

Setting item	Description
English	All parameters, alarm messages, etc. displayed in English.
Japanese	All parameters, alarm messages, etc. displayed in Japanese katakana.
French	All parameters, alarm messages, etc. displayed in French.
German	All parameters, alarm messages, etc. displayed in German.
Italian	All parameters, alarm messages, etc. displayed in Italian.
Spanish	All parameters, alarm messages, etc. displayed in Spanish.

T0614.EPS

[B20: Flow Damping] Setting of the damping time constant

→ This setting is linked with that of parameter **C11**. The damping time constant should be modified to suppress an output fluctuation or to change the response time. This time constant has an effect on analog output and on the flow rate display (i.e., actual instantaneous flow rate, %, current value), and in addition, it also affects pulse output and totalization. However, when “No Damping” has been set for **J24: T/P Damp Select**, there will be no effect on pulse output or totalization.

* Time constant: The time required for the output to reach 63.2% from 0%.

[B21: Base Flow Unit] Selection of flow units for the flow rate span

→ This setting is linked with that of parameter **C40**. This parameter selects the flow units for the flow rate span. (In case of mass flow, the setting of density is also required. Refer to **C46: Mass Flow Density** for more details.)

[B22: Base Time Unit] Selection of time units for the flow rate span

→ This setting is linked with that of parameter **C41**. This parameter selects the time units for the flow rate span; however, if “m” or “ft” has been selected for the flow rate units, “/s” is automatically set for this parameter.

[B23: Flow Span] Setting of the flow rate span

→ This setting is linked with that of parameter **C42**. The span can be set for the forward flow rate in the range 0 to 32,000 (although this does not include 0). The units set using **B21/C40: Base Flow Unit** and **B22/C41: Base Time Unit** will be displayed at this time.



NOTE

If the flow rate units, time units, and flow rate span are specified upon ordering, these parameters will be setup before shipment; however, if this is not the case, it will be necessary for the appropriate values to be set up by the user.



NOTE

Flow rate span is the value for instantaneous flow rate that corresponds to a current output of 20 mA. The following factors should be taken into consideration when deciding on the flow rate span.

- In the case of applications with large variations in flow rate, the maximum flow rate should be set. If a flow rate in excess of the flow rate span was to occur, output would be possible up to an upper limit of 108%, and beyond this, error would occur. Note that the same applies to pulse output and totalization.
- In the case of applications that have a relatively stable flow rate, a flow rate span of 1.5 to 2.0 times larger than the normal flow rate may be considered suitable.
- The flow rate to be adopted should - upon conversion to flow velocity - correspond to a value within the range of 0.1 to 10 m/s. (0.3 to 10 m/s for size 1100 mm or larger) The flow velocity can be confirmed using sizing data or with parameter **C44: Velocity Check**, and in the latter case, the value obtained when span is converted to flow velocity will be displayed.
- Regardless of the position of the decimal point, the largest value that can be set on the display unit is 32,000. Furthermore, it is not possible to set a number of 4 or greater for the highest-order digit. Similarly, if 3 is set for this highest-order digit, it will not be possible to set a

number of 2 or greater for the next digit to the right, regardless of the position of the decimal point.

Example: A value of 333.33 is represented by the character string 33333, and since this exceeds 32000, it cannot be set. In such a case, the value 333.3 should be set instead.

[B24: Flow Decimal Pnt] Setting of the decimal point position for the instantaneous flow rate
 → This setting is linked with that of parameter **C43**. This parameter sets the position of the decimal point for instantaneous flow rate values in terms of the number of digits. When set using “Auto”, the decimal point position will be automatically determined in accordance with the setting value for **B23/C42: Flow Span** as shown below.

Flow Span ≤ 9	Decimal point position: 3 digits
9 < Flow Span ≤ 90	Decimal point position: 2 digits
90 < Flow Span ≤ 900	Decimal point position: 1 digit
900 < Flow Span	Decimal point position: no digits (i.e., no decimal point)

When an item other than “Auto” is set, the selected number of digits for the decimal point position is used.

With the decimal point removed, 6 digits are available for the instantaneous flow rate value, and display is possible up to 999,999. If an overflow occurs as a result of the setting adopted for decimal point position, the warning **84: Disp Over Wng** will be displayed to provide notification of this condition.

Example: When 1000 m³/h is set for B23/C42: Flow Span

Item	Display content for instantaneous flow rate value
Auto	1000 m ³ /h
0	1000 m ³ /h
1	1000.0 m ³ /h
2	1000.00 m ³ /h
3	With the decimal point removed, 7 digits are not available for the instantaneous flow rate value; therefore, a warning is displayed.

T0615.EPS

[B30: Total Unit] Setting of units for totalization scale

→ This setting is linked with that of parameter **D10**. This parameter selects the flow rate units for use in totalization.

Item	Description
n Unit/P	10 ⁻⁹ ×FU
u Unit/P	10 ⁻⁶ ×FU
m Unit/P	10 ⁻³ ×FU
Unit/P	FU
k Unit/P	10 ³ ×FU
M Unit/P	10 ⁶ ×FU
Pulse/s	Number of pulses to be counted for one second at 100% output.

FU: Flow rate unit selected in B21/C40; Base Flow Unit.

T0616.EPS

[B31: Total Scale] Setting of the totalization scale
 → This setting is linked with that of parameter **D11**. The flow rate is totalized in individual counts in accordance with this parameter’s setting. If 0 is selected, it indicates that the totalization function is not to be used.

**NOTE**

If a totalization scale is specified upon ordering, this parameter is set up before shipment; however, if this is not the case, it will be necessary for the appropriate value to be set up by the user.

**NOTE**

- By setting the totalization scale, the totalized value is displayed on the display unit. The totalization scale is determined in accordance with the settings of **B30/D10: Total Unit** and **B31/D11: Total Scale**.
- The maximum value that can be displayed is 99999999, and if this is exceeded, the value 0 is counted once again. However, counting stops at 99999999 when the totalization switch function is used.
- If multiple ranges are being used, the flow rate span for the smallest range becomes the standard for the **D13: Total Low Cut** setting value.
- Totalization for the reverse flow rate and for the differential flow rate is carried out only when “Fwd/Rev Ranges” is selected for **F10: SO1 Function** or **F11: SO2 Function**.
- The totalized units are indicated on the display unit when **B31/D11** is 0.001, 0.01, 0.1, 1, 10, 100, or 1000. In the case of other setting values, the totalized units are not indicated.

Example 1: To count in 1 MI (mega-liter) steps with flow rate span = 100 m³/h
 Since 1 MI = 10³ x m³, k Unit/P is set for **B30/D10**, and 1 is set for **B31/D11**. "x10³ m³" is indicated for the totalized units in the Display Mode.

Example 2: To count in 10 l (liter) steps with flow rate span = 100 m³/h
 Since 1 l = 10⁻³ x m³, m Unit/P is set for **B30/D10**, and 10 is set for **B31/D11**. "x10⁻² m³" is indicated for the totalized units in the Display Mode.

Example 3: To count in 5 l (liter) steps with flow rate span = 100 m³/h
 Since 1 l = 10⁻³ x m³, m Unit/P is set for **B30/D10**, and 5 is set for **B31/D11**. Since **B31/D11** is not 0.001, 0.01, 0.1, 1, 10, 100, or 1000, there is no indication of totalized units in the Display Mode.

- Setting of totalization scale is not possible when specific selections have been made for **B30/D10: Total Unit**, **B31/D11: Total Scale**, and **B23/C42: Flow Span**. In such a case, a setting alarm will be displayed, and parameters should be changed in accordance with the instructions given.

[B32: Pulse Unit] Setting of the pulse units

→ This setting is linked with that of parameter **E10**.

This parameter selects the flow rate units to be used for pulse output.

Item	Description
n Unit/P	10 ⁻⁹ ×FU
u Unit/P	10 ⁻⁶ ×FU
m Unit/P	10 ⁻³ ×FU
Unit/P	FU
k Unit/P	10 ³ ×FU
M Unit/P	10 ⁶ ×FU
Pulse/s	Number of pulses to be output for one second at 100% output.

FU: Flow rate unit selected in B21/C40: Base Flow Unit.

T0617.EPS

[B33: Pulse Scale] Setting of pulse scale

→ This setting is linked with that of parameter **E11**.

Pulse output is performed in individual counts in accordance with this parameter's setting. If 0 is selected, it indicates that the pulse output function is not to be used.



NOTE

If a pulse scale is specified upon ordering, this parameter is setup before shipment; however, if this is not the case, it will be necessary for the appropriate value to be setup by the user.



NOTE

- By setting the pulse scale, pulse output performs. The pulse scale is determined in accordance with the settings of **B32/E10: Pulse Unit** and **B33/E11: Pulse Scale**.
- If multiple ranges are being used, the flow rate span for the smallest range becomes the standard for the **E13: Pulse Low Cut** setting value.
- Pulse output for the reverse flow rate is carried out only when "Fwd/Rev Ranges" is selected for **F10: SO1 Function** or **F11: SO2 Function**.
- Setting of pulse scale is not possible when specific selections have been made for **B32/E10: Pulse Unit**, **B33/E11: Pulse Scale**, **E12: Pulse Width** and **B23/C42: Flow Span**. In such a case, a setting alarm will be displayed, and parameters should be changed in accordance with the instructions given.

Example 1: To perform pulse output in 1 MI (mega-liter) steps with flow rate span = 100 m³/h
 Since 1 MI = 10³ x m³, M Unit/P is set for **B32/E10**, and 1 is set for **B33/E11**.

Example 2: To perform pulse output in 10 l (liter) steps with flow rate span = 100 m³/h
 Since 1 l = 10⁻³ x m³, m Unit/P is set for **B32/E10**, and 10 is set for **B33/E11**.

Example 3: To perform pulse output in 5 l (liter) steps with flow rate span = 100 m³/h
 Since 1 l = 10⁻³ x m³, m Unit/P is set for **B32/E10**, and 5 is set for **B33/E11**.

[B40: Display Select1] Setting of the first line for display unit

→ This setting is linked with that of parameter **H10**. This parameter selects the display content of the first line for display unit. The size of the characters which are displayed will depend on the selections made for

B41/H11: Display Select2 and **B42/H12: Display Select3** as described below. (For more details, refer to Chapter 5: Basic Operating Procedures.)



CAUTION

It is not possible to set Display Select1 to “Off”.

[B41: Display Select2] Setting of the second line for display unit

→ This setting is linked with that of parameter **H11**. This parameter selects the display content of the second line for display unit. When “Off” is selected, one-line display will be adopted regardless of the setting made for **B42/H12: Display Select 3**.

[B42: Display Select3] Setting of the third line for display unit.

→ This setting is linked with that of parameter **H12**. This parameter selects the display content of the third line for display unit. When “Off” is selected for this parameter, two-line display is adopted.

[B50: Auto Zero Exe] Execution of the automatic zero adjustment function

→ This setting is linked with that of parameter **M10**. This parameter executes the automatic zero adjustment function: If “Execution” is selected, this function will be started. “Now Auto Zero Executing...” is indicated while the Auto Zero function is being carried out. The result of the automatic zero adjustment is confirmed using **M11: Magflow Zero**, and if the result exceeds the rated value, the warning **82: Auto Zero Wng** will be displayed. (For more details, refer to Chapter 9: Operation.)

Setting	Function
No Execution	No execution
Execution	Automatic zero adjustment is started.

T0643.EPS

(2) Menu C: Basic Setting items

Menu C principally contains the basic setting items for the flowtube.



NOTE

In order to ensure that correct flow rate data can be acquired, it is crucial that the nominal size, flow rate span, and meter factor of the combined remote flowtube are setup. In cases where a remote flowtube is ordered at the same time as the AXFA11, the nominal size and meter factor

will be setup upon shipment from the manufacturing plant, and these will not require additional setting. If the AXFA11 is ordered individually, the default value will be setup for the meter factor; accordingly, it will be necessary to set the meter factor indicated on your remote flowtube data plate.

If a flow rate span is specified upon ordering, this will be set before shipment. If this is not the case, however, it will be necessary for the appropriate value to be set up by the user.

[C10: Tag No] Setting of the tag number

→ The setting for this parameter corresponds to one of the ordered items.

Up to a maximum of 16 characters can be entered for the display unit. For more details regarding the actual characters that can be used, refer to Section 5.2.2: Setting Mode.



NOTE

If a tag number is specified upon ordering, this parameter is set up before shipment; however, if this is not the case, it will be necessary for the appropriate value to be set up by the user.

[C11: Flow Damping] Setting of the damping time

→ Refer to the description of parameter **B20**.

[C20: Measure Mode] Selection of dual frequency excitation mode

Item	Description
Standard DF	Standard dual frequency excitation
Enhanced DF	Enhanced dual frequency excitation

T0618.EPS

Enhanced DF (i.e., enhanced dual frequency excitation) is set to stabilize measurement for difficult applications, such as for high concentration slurries or low conductivity fluid. Note that this parameter is only valid when this product is used in combination with an AXF flowtube, as only supports enhanced dual frequency excitation. (Optional code HF1 or HF2)



NOTE

•When this product is used in combination with any flowtube that does not support enhanced dual frequency excitation and “Enhanced DF” is

selected, a setting alarm will be displayed. The setting should be returned to “Standard DF” in such a case.

- When dual frequency excitation mode is changed, perform zero adjustment. For details on zero adjustment, refer to chapter 9.

[C21: Low MF] Setting of the low-frequency meter factor

This parameter sets the low-frequency meter factor for standard dual frequency excitation.

This parameter is also used for pulsed DC excitation in which AXFA11 is combined with a remote flowtube the size of 500 mm (20 in.) or larger.

[C22: High MF] Setting of the high-frequency meter factor

This parameter sets the high-frequency meter factor for standard dual frequency excitation.

If AXFA11 combined with a remote flowtube the size of 500 mm or larger, high-frequency meter factor need not be set.



NOTE

Meter Factor Settings

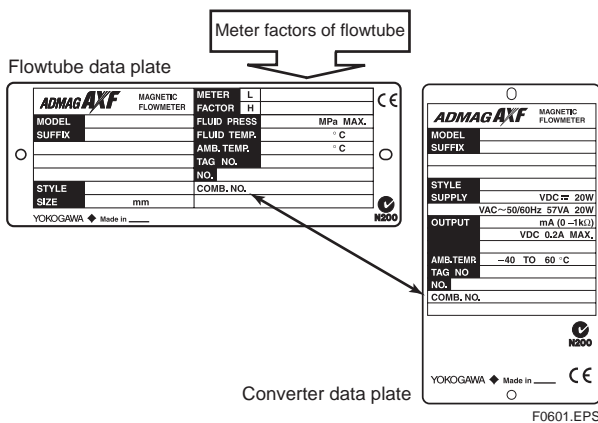

- (1) Confirm that the serial number indicated by COMB.NO. on the AXFA11 converter's data plate corresponds with the AXF Remote Flowtube's serial number.
- (2) Set the values that are marked in the METER FACTOR fields on the data plate for the Remote Flowtube.
- (3) The meter factors are crucial in ensuring that the electromotive force is correctly in proportion to the flow velocity and are determined at the manufacturing plant by actual-flow calibration.

[C23: Low MF (EDF)] Setting of the low-frequency meter factor for EDF

This parameter sets the low-frequency meter factor as required when Enhanced DF (i.e., enhanced dual frequency excitation) is selected. If “Standard DF” has been selected for **C20: Measure Mode**, neither **C23: Low MF (EDF)** nor **C24: High MF (EDF)** is displayed, and if “Enhanced DF” is selected, the four parameters from **C21** to **C24** will be displayed.

[C24: High MF (EDF)] Setting of the high-frequency meter factor for EDF

This parameter sets the high-frequency meter factor as required when Enhanced DF (i.e., enhanced dual frequency excitation) is selected.

[C30: Select Flow Tube] Setting of the flowtube's model

This parameter sets the models of flowtube. When combining this product with an AXF Remote Flowtube, “ADMAG AXF” should be selected.

[C31: Nominal Size Unit] Setting of the nominal size units

This parameter selects the units used for setting of the nominal size.

[C32: Nominal Size] Setting of the nominal size

This parameter sets the nominal size of flowtube.

[C40: Base Flow Unit] Selection of flow units for the flow rate span

→ Refer to the description of parameter **B21**.

[C41: Base Time Unit] Selection of time units for the flow rate span

→ Refer to the description of parameter **B22**.

[C42: Flow Span] Setting of the flow rate span

→ Refer to the description of parameter **B23**.

[C43: Flow Decimal Pnt] Setting of the decimal point position for the instantaneous flow rate

→ Refer to the description of parameter **B24**.

[C44: Velocity Check] Display of the flow rate span velocity

This parameter displays the flow rate span for the maximum range in m/s units.

[C45: Density Unit] Setting of the density units for mass flow rate

This parameter selects the units for density as required when making settings using **C46: Mass Density**.

[C46: Mass Density] Setting of the density for mass flow rate

This parameter is necessary in situations where t, kg, g, klb or lb has been selected as the mass unit in **B21/C40: Base Flow Unit**. If a mass unit is selected in **B21/C40: Base Flow Unit** and a value of 0 is set for this parameter, the setting alarm “**57: Dens Set Err**” will be displayed. In such a case, ensure that the density is set correctly.

[C47: User Span Select] Selection of the use of special flow rate units.

This parameter selects whether or not special units are used for instantaneous flow rate. Actual setting of these units is carried out using **C48: Flow User Unit** and **C49: Flow User Span**.

[C48: Flow User Unit] Setting of the special flow rate units

This parameter is used to select the special units (up to maximum of 8 characters in length). These units are displayed when instantaneous flow rate is selected in the Display Mode, and they are displayed for **A20: FLOW RATE** when BRAIN communication is being carried out.

[C49: Flow User Span] Setting of the special flow rate span

This parameter sets the special flow rate span to be displayed for 100% output in the maximum range.



NOTE

Example : To set the special flow rate span to 100 dl/s
 Since 100 dl (deci-liter)=10 l (liter),
 “l (Liter)” is set for **B21/C40: Base Flow Unit**,
 “/s” is set for **B22/C41: Base Time Unit**,
 “10” is set for **B23/C42: Flow Span**,
 “Yes” is set for **C47: User Span Select**,
 “dl/s” is set for **C48: Flow User Unit**,
 “100” is set for **C49: Flow User**

Span.

“100 dl/s” is indicated for 100% output in the Display Mode.

(3) Menu D: Total Setting items

Menu D contains parameters that are relevant to totalization function settings.

[D10: Total Unit] Setting of units for totalization scale

→ Refer to the description of parameter **B30**.

[D11: Total Scale] Setting of the totalization scale

→ Refer to the description of parameter **B31**.

[D12: Total Decimal Pnt] Setting of the decimal point position for the totalization display

This parameter sets the position of the decimal point for totalization display in terms of the number of digits. Except in cases where 0 is selected, the totalized units are not displayed.

Example: When totalized value is 12345678 m³

Item	Totalization display
0	12345678 m ³
1	1234567.8
2	123456.78
3	12345.678
4	1234.5678
5	123.45678
6	12.345678
7	1.2345678

T0619.EPS

[D13: Total Low Cut] Setting of the totalization stop range

This parameter allows the settings to be made that prevent totalization when the flow rate is at or below the low-cut setting value. In cases where there are multiple ranges or forward/reverse ranges, low cut is carried out at the setting value for the smallest span (i.e., an integer between 0 and 10%).

Example: When the first range = 10 m³/h, the second range = 100 m³/h, and the Total Low Cut = 3%, no totalization is carried out at flow rates of 0.3 m³/h or lower.

[D20: Total Execution] Operation setting for the totalization function

This parameter sets “Start” and “Stop” of the totalization function, in addition to performing the preset function for the forward totalized value and the reverse totalized value.

*: The preset function starts the count for totalization from the set value.

Item	Description
Start (initial value)	Starts totalization
Stop	Stop totalization
Preset Total	Sets the preset value for totalization display that has been specified as the forward totalized value. Preset value are determined using D21: Ttl Set Val Lower and D22: Ttl Set Val Upper . In case that “Start” is selected, the count for totalization starts from the preset value. Setting of zero as the preset value allows the zero-reset function to be implemented.
Preset Rev Total	Sets the preset value for totalization display that has been specified as the reverse totalized value. Preset value are determined using D21: Ttl Set Val Lower and D22: Ttl Set Val Upper . In case that “Start” is selected, the count for totalization starts from the preset value. Setting of zero as the preset value allows the zero-reset function to be implemented.

T0620.EPS

**NOTE**

Totalization presets can also be set up by using status input. For details regarding the setting method, refer to the descriptions of **F12** and **F13**.

[D21: Ttl Set Val Lower] Setting of the totalization preset value (lower 6 digits)

This parameter sets a totalization preset value in the lower 6 digits of the 8-digit totalized value. If zero is to be set as the preset value, “000000” should be set here.

[D22: Ttl Set Val Upper] Setting of the totalization preset value (upper 2 digits)

This parameter sets a totalization preset value in the upper 2 digits of the 8-digit totalized value. If zero is to be set as the preset value, “00” should be set here.

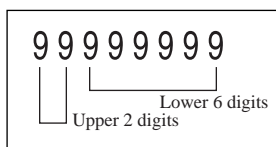

F0602.EPS

[D23: Ttl Switch Lower] Setting of the totalization switch value (lower 6 digits)

The totalization switch function operates to set the status output terminal (i.e., SO1 or SO2) to “Closed (On)” when the forward internal totalized value reaches or exceeds the totalization switch value. (For details regarding the setting method for the status output, refer to the descriptions of parameters **F10** and **F11**.)

If this function is set up, the totalization count will stop at 99999999.

D23 sets the lower 6 digits of the 8-digit totalization switch value.

[D24: Ttl Switch Upper] Setting of the totalization switch value (upper 2 digits)

This parameter sets the upper 2 digits of the 8-digit totalization switch value.

[D30: Ttl User Select] Selection of the use of special totalization unit

This parameter specifies whether or not special units are used for totalized units. Actual setting of these units is carried out using **D31: Ttl User Unit**.

[D31: Ttl User Unit] Setting of special totalization units

Units of up to maximum 8 characters in length can be specified using this parameter. The units set with this parameter are displayed whenever totalization (i.e., FTL, RTL, DTL) is selected in the Display Mode, and they are displayed for **A30: TOTAL**, **A31: REV TOTAL**, and **A32: DIF TOTAL** when BRAIN communication is being carried out.

**NOTE**

Example: To count in 1 dl (deci-liter) steps with flow rate span=10 l/s.
Since 1 dl (deci-liter) = 0.1 l (liter), “l (Liter)” is set for **B21/C40: Base Flow Unit**,
“/s” is set for **B22/C41: Base Time Unit**,
“10” is set for **B23/C42: Flow Span**,
“Unit/P” is set for **B30/D10: Total Unit**,
“0.1” is set for **B31/D11: Total Scale**,
“Yes” is set for **D30: Ttl User Select**,

and “dl” is set for **D31: Ttl User Unit**.

“dl” is indicated for the totalized units in the Display Mode and is counted in 1 dl steps.

(4) Menu E: Pulse Setting items

Menu E contains items relevant to pulse output.

[E10: Pulse Unit] Setting of the pulse units
 → Refer to the description of parameter **B32: Pulse Unit**

[E11: Pulse Scale] Setting of the pulse scale
 → Refer to the description of parameter **B33: Pulse Scale**

[E12: Pulse Width] Setting of the pulse width
 This parameter selects the pulse width (i.e., ms : millisecond) that is output.

Data Range

Setting	Pulse Rate (pps)	
	Maximum Value	Minimum Value
(0) 50% Duty	11000	0.0001 (pps: pulses per second)
(1) 0.05ms	10000	
(2) 0.1ms	5000	
(3) 0.5ms	1000	
(4) 1ms	500	
(5) 20ms	25	
(6) 33ms	15	
(7) 50ms	10	
(8) 100ms	5	

T0621.EPS

[E13: Pulse Low Cut] Setting of the pulse output stop range

This parameter allows the settings to be made which prevent pulse output when the flow rate is at or below the low-cut setting value. In cases where there are multiple ranges or forward/reverse ranges, low cut is carried out at the setting value for the smallest span (i.e., an integer between 0 and 10%).

Example: When the first range = 10 m³/h, the second range = 100 m³/h, and the Pulse Low Cut = 3%, no pulse output is carried out at flow rates of 0.3 m³/h or lower.

[E20: Pulse Active Mode] Setting of active mode for pulse output

This parameter sets whether pulse-output active mode is to be “On Active” or “Off Active”.

Item	Description
Closed (On) Act	When pulse output is carried out, contacts are Closed (On).
Open (Off) Act	When pulse output is carried out, contacts are Open (Off).

T0622.EPS

Example: When **E12: Pulse Width** is 1 ms, output takes place as follows in accordance with the setting for **E20: Pulse Active Mode**.

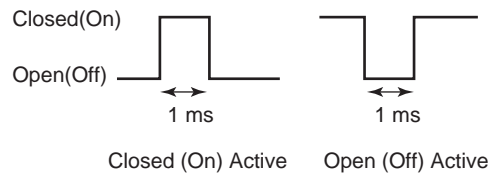

F0604.EPS



NOTE

*:The pulse width with the exception of “50% Duty” is the “Closed (On)” time for each pulse in case that “Closed (On) Act” is selected for **E20: Pulse Active Mode**.

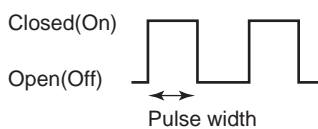

F0603.EPS

A limit applies to the maximum pulse scale that can be set with respect to the pulse width. If a value in excess of this limit is set, a setting alarm will be displayed.

(5) Menu F: Status Functions Setting items

Menu F contains setting items relevant to status Input/Output functions.

[F10: SO1 Function] Setting of the function for the SO1 status output terminal

This parameter sets the function for the SO1 (status output 1) terminal.

Setting	Function	Description
No Function	Stop output (i.e., inactive condition)	As no function is set, there is no output.
Warning Output	Output upon warning	Refer to Alarms (Section 6.5)
Total Switch	Totalization switch output	Status output is carried out when the forward internal totalized value reaches or exceeds the totalization switch value. The totalization switch value is determined using D23: Ttl Switch Lower and D24: Ttl Switch Upper .
H/L Alarm	H/L alarm output	Status output is carried out when the instantaneous flow rate equals or falls below the low flow rate limit (L), or when it equals or exceeds the high flow rate limit (H). These limit values are determined using G10: Low Alarm and G11: High Alarm .
HH/LL Alarm	HH/LL alarm output	Status output is carried out when the instantaneous flow rate equals or falls below the low-low flow rate limit (LL), or when it equals or exceeds the high-high flow rate limit (HH). These limit values are determined using G12: Low Low Alarm and G13: High-High Alarm . To output "HH/LL Alarm" as an alarm, set G33: Alm-HH/LL to "Yes".
Fwd/Rev Ranges	Forward/reverse flow rate measurement	When flow is in the reverse direction, switching to the reverse range is carried out automatically, measurement is performed, and status output is carried out.
Auto 2 Ranges	Automatic 2 ranges switching	This function ensures that when the instantaneous flow rate exceeds 100% of the range, transition to the next range is carried out automatically. Status output is carried out upon range switching.
Auto 3 Ranges	Automatic 3 ranges switching (Note 1)	
Auto 4 Ranges	Automatic 4 ranges switching (Note 1)	
Ext 2 Answer	Answerback: 2 ranges switching via external status input	When range switching is carried out in response to external status input, status output is performed in the form of an answerback to indicate the range currently being used.
Ext 3 Answer	Answerback: 3 ranges switching via external status input (Note 1)	
Ext 4 Answer	Answerback: 4 ranges switching via external status input (Note 1)	

Note 1: When these functions are selected, two terminals become necessary for status output.

Accordingly, the setting for **F10: SO1 Function** is automatically adopted as the setting for **F11: SO2 Function**. (Setting of these functions is not possible using **F11: SO2 Function**.)

Note 2: Function-specific SO1 and SO2 operations

Operations are performed in accordance with the content of the following table when the active mode has been set to "Closed (On) Act" using **F14: SO1/2 Active Mode**.

Operating patterns are reversed when the active mode has been set to "Open (Off) Act" using this parameter.

T0623.EPS

Selected function	Condition of SO1 or SO2 terminal	
	Open (Off)	Closed (On)
Warning Output	Good (normal)	Warning status
Total Switch	Below setting value	Equal or above setting value
H/L Alarm	Normal	H/L alarm status
HH/LL Alarm	Normal	HH/LL alarm status
Fwd/Rev Ranges	Forward direction	Reverse direction

Note: For "Auto 2 Ranges," "Auto 3 Ranges," "Auto 4 Ranges," "Ext 2 Answer," "Ext 3 Answer," and "Ext 4 Answer," see the **Multiple ranges setting** section.

T0624.EPS

[F11: SO2 Function] Setting of function for the SO2 status output terminal

This parameter sets the function for the SO2 (status output 2) terminal. Selectable functions are the same as for **F10: SO1 Function**; however, the selection of "Auto 3 Ranges", "Auto 4 Ranges", "Ext 3 Answer", or "Ext 4 Answer" is not possible for **F11**.

[F12: SI1 Function] Setting of the function for the SI1 status input terminal

This parameter sets the function for the SI1 (status input 1) terminal.

Setting	Function	Description
No Function	No input function	
0% Signal Lock	0% signal lock via external status input.	Based on the external status input, the instantaneous flow rate indication is forcibly set to 0% (i.e., 4 mA), and both totalization and pulse outputs are halted. This setting has precedence over the output signal whenever an alarm occurs. When 0% signal lock is canceled, the instantaneous flow rate is restored in accordance with the time constant originally set using B20/C11:Flow Damping .
Ext Auto Zero	Automatic zero adjustment via external status input	Automatic zero adjustment is carried out in response to external status input. For more details regarding automatic zero adjustment, refer to Chapter 9: Operation.
Ext Ttl Preset	Forward totalization preset via external status input	The totalization display value is preset or reset to zero in accordance with the external status input. The preset value is determined using D21: Ttl Set Val Lower and D22: Ttl Set Val Upper .
Ext Rev Ttl Set	Reverse totalization preset via external status input	In case that "Start" is selected for D20: Total Execution , the count for totalization starts from the preset value.
Ext 2 Ranges	2 ranges switching via external status input	This function allows switching of up to 4 ranges in response to status input for a single direction only.
Ext 3 Ranges	3 ranges switching via external status input (Note 1)	
Ext 4 Ranges	4 ranges switching via external status input (Note 1)	

Note 1: When these functions are selected, two terminals become necessary for status input.

Accordingly, the setting for **F12: SI1 Function** is automatically adopted as the setting for **F13: SI2 Function**. (Setting of these functions is not possible using **F13: SI2 Function**.)

Note 2: Function-specific SI1 and SI2 operations

Operations are performed in accordance with the content of the following table when the active mode has been set to "Short Active" using **F15: SI1/2 Active Mode**.

Operating patterns are reversed when the active mode has been set to "Open Active" using this parameter.

T0625.EPS

Selected function	Condition of SI1 or SI2	
	Open	Short
0% Signal Lock	Normal	Signal lock status
Ext Auto Zero	Normal	Start of automatic zero adjustment
Ext Ttl Preset	Normal	Forward totalization preset
Ext Rev Ttl Set	Normal	Reverse totalization preset

Note: For "Ext 2 Ranges," "Ext 3 Ranges," and "Ext 4 Ranges," see the **Multiple ranges setting** section.

T0626.EPS

[F13: SI2 Function] Setting of the function for the SI2 status input terminal

This parameter sets the function for the SI2 (status input 2) terminal. Selectable functions are the same as for **F12: SI1 Function**; however, the selection of Ext 3 Ranges and Ext 4 Ranges is not possible for **F13**.

[F14: SO1/2 Active Mode] Setting of the active mode for status output

This parameter sets the active mode for the terminals SO1 and SO2. Active modes cannot be set individually for these two terminals.

Setting	Function
Closed (On) Act	Status output becomes "Closed (On)" when an event occurs.
Open (Off) Act	Status output becomes "Open (Off)" when an event occurs.

T0627.EPS

Example: When the "Total Switch" function is selected for SO1 or SO2

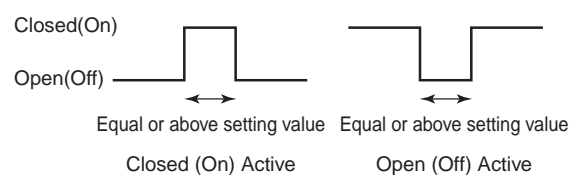

F0605.EPS

[F15: SI1/2 Active Mode] Setting of the active mode for status input

This parameter sets the active mode for the terminals SI1 and SI2. Active modes cannot be set individually for these two terminals.

Setting	Function
Short Active	When the status input is set to "Short", occurrence of the selected event will be recognized.
Open Active	When the status input is set to "Open", occurrence of the selected event will be recognized.

T0628.EPS

Example: When the "0% signal lock" function is selected for SI1 or SI2

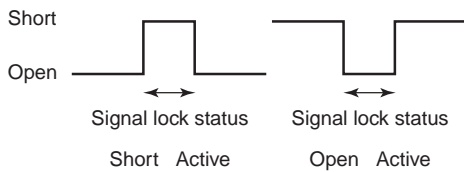

F0606.EPS



NOTE

Multiple ranges setting

Parameters from **F30** to **F41** are used with the automatic multiple ranges and the multiple ranges switching via external status input. The followings will describe the setting method for each range.

The multiple ranges use the following parameters:

[B23: Flow Span] Setting of the flow rate span (Setting of the forward No.1 range)

[F30: Forward Span 2] Setting of the forward No. 2 range

[F31: Forward Span 3] Setting of the forward No. 3 range

[F32: Forward Span 4] Setting of the forward No. 4 range

[F33: Reverse Span 1] Setting of the reverse No. 1 range

[F34: Reverse Span 2] Setting of the reverse No. 2 range

[F35: Reverse Span 3] Setting of the reverse No. 3 range

[F36: Reverse Span 4] Setting of the reverse No. 4 range

[F40: Auto Range Hys] Setting of the automatic multiple range hysteresis width

[F41: Bi Direction Hys] Setting of the forward/reverse flow measurement hysteresis width

Multiple Ranges Setting 1: Automatic multiple ranges switching

- When the instantaneous flow rate exceeds 100% of the range, transition to the next range (up to four ranges) is carried out automatically. Furthermore, when the flow is in reverse, the reverse range can also be automatically selected.
- Range switching can be confirmed according to the status of the SO1 and SO2 status output terminals. Refer to Table 6.4.1: Status Output for Automatic Multiple Ranges Switching for details of status output conditions for each range.

Status Output for Automatic Multiple Ranges Switching

Operations are performed in accordance with the following table when the active mode has been set to "Closed (On) Act" using **F14: SO1/2 Active Mode**. Operating patterns are reversed when the active mode has been set to "Open (Off) Act".

Table 6.4.1 Status Output for Automatic Multiple Ranges Switching

Parameter setting		Function	Status output	
F10	F11		SO1	SO2
No Function	No Function	Forward single range	-	-
Fwd/Rev Ranges	No Function	Auto forward/reverse 1 range (SO1)	Forward: Open Reverse: Closed	-
No Function	Fwd/Rev Ranges	Auto forward/reverse 1 range (SO2)	Forward: - Reverse: -	Open Closed
Auto 2 Ranges	No Function	Auto forward 2 ranges (SO1)	Forward 1 range: Open Forward 2 range: Closed	-
No Function	Auto 2 Ranges	Auto forward 2 ranges (SO2)	Forward 1 range: - Forward 2 range: -	Open Closed
Auto 3 Ranges	Auto 3 Ranges	Auto forward 3 ranges	Forward 1 range: Open Forward 2 range: Closed Forward 3 range: Open	Open Open Closed
Auto 4 Ranges	Auto 4 Ranges	Auto forward 4 ranges	Forward 1 range: Open Forward 2 range: Closed Forward 3 range: Open Forward 4 range: Closed	Open Open Closed Closed
Fwd/Rev Ranges	Auto 2 Ranges	Auto forward/reverse 2 ranges	Forward 1 range: Open Forward 2 range: Open Reverse 1 range: Closed Reverse 2 range: Closed	Open Closed Open Closed
Auto 2 Ranges	Fwd/Rev Ranges	Auto forward/reverse 2 ranges	Forward 1 range: Open Forward 2 range: Closed Reverse 1 range: Open Reverse 2 range: Closed	Open Open Closed Closed

*: "No Function" is the default value. Only SO1 or SO2 terminals are used for single or dual ranges; accordingly, the unused terminal remains at the default value (i.e., No Function) and can therefore be used for other functions.

**Parameter setting sequence
(for automatic multiple ranges switching)**

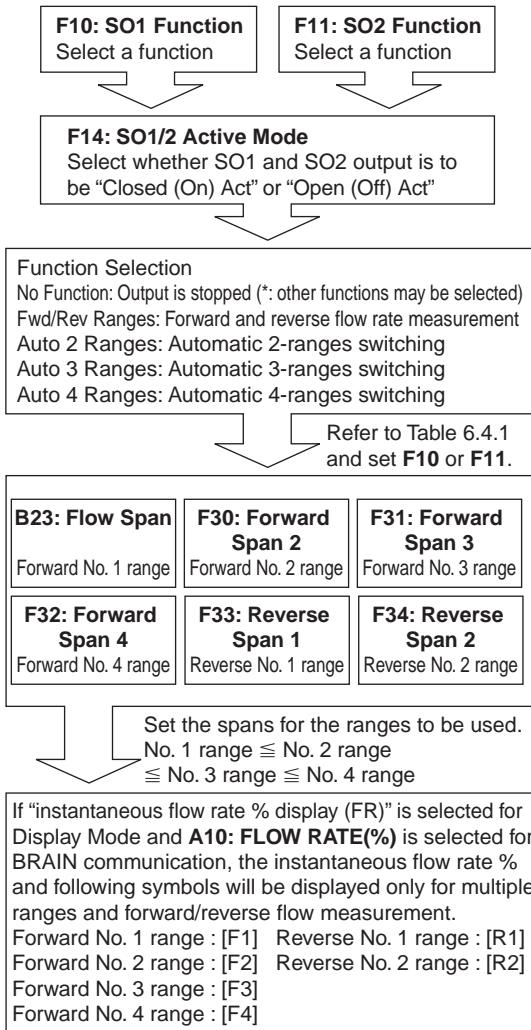

F0607.EPS

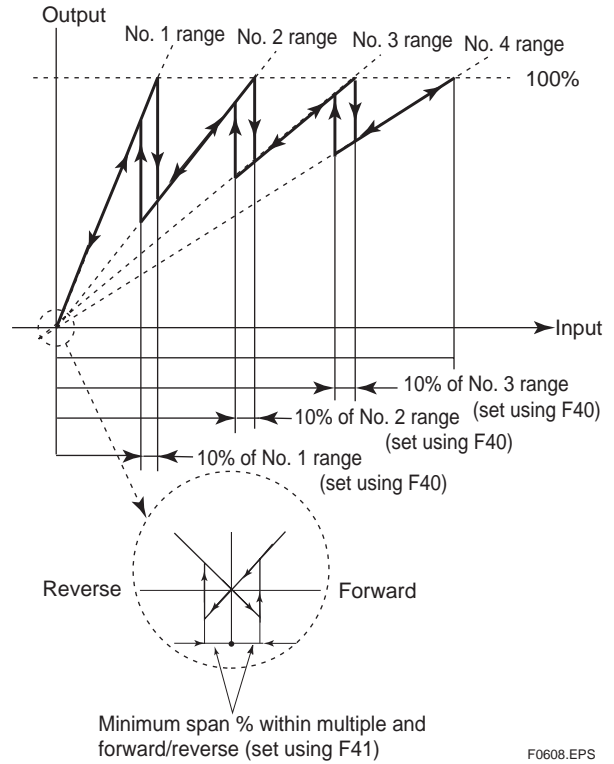

F0608.EPS

Figure 6.4.1 Multiple Ranges and Hysteresis Widths



NOTE

For more details regarding the setting of hysteresis width, refer to the description of setting parameter for **F40: Auto Range Hys** and **F41: Bi Direction Hys**.

**Multiple Ranges Setting 2:
Multiple ranges switching via external status input**

- For both the forward and reverse directions, switching of up to four ranges can be carried out based on status input; however, switching between directions is not possible. Switching between forward and reverse ranges is carried out automatically only when the flow direction reverses.
- SI1 and SI2 status input terminals are used for multiple range switching. For more details, refer to Table 6.4.2: Multiple Ranges Switching via External Status Input.

Multiple Ranges Switching via External Status Input

Operations are performed in accordance with the following table when the active mode has been set to “Closed (On) Act” using **F14: SO1/2 Active Mode** and when the active mode has been set to “Short Active” using **F15: SI1/2 Active Mode**. Operating patterns are reversed when the active mode has been set to “Open (Off) Act” using **F14**; and “Open Active”, using **F15**.

Table 6.4.2 Multiple Ranges Switching via External Status Input

Parameter setting				Function	Status input		Status output	
F10	F11	F12	F13		SI1(F12)	SI2(F13)	SO1(F10)	SO2(F11)
No Function	No Function	Ext 2 Ranges	No Function	External forward 2 ranges	Forward 1 range	Open	–	–
No Function	No Function	No Function	Ext 2 Ranges		Forward 2 range	Short	–	–
No Function	No Function	Ext 3 Ranges	Ext 3 Ranges	External forward 3 ranges	Forward 1 range	Open	Open	–
No Function	No Function	Ext 4 Ranges	Ext 4 Ranges		Forward 2 range	Short	Open	–
No Function	No Function	Ext 4 Ranges	Ext 4 Ranges		Forward 3 range	Open	Short	–
Fwd/Rev Ranges	No Function	Ext 2 Ranges	No Function	External forward/reverse 2 ranges	Forward 1 range	Open	Open	Open
Fwd/Rev Ranges	No Function	No Function	Ext 2 Ranges		Forward 2 range	Short	Open	Open
No Function	Fwd/Rev Ranges	Ext 2 Ranges	No Function		Reverse 1 range	Open	–	Open
No Function	Fwd/Rev Ranges	No Function	Ext 2 Ranges		Reverse 2 range	Short	–	Open
Fwd/Rev Ranges	No Function	Ext 3 Ranges	Ext 3 Ranges	External forward/reverse 3 ranges	Forward 1 range	Open	Open	Open
Fwd/Rev Ranges	No Function	Ext 3 Ranges	Ext 3 Ranges		Forward 2 range	Short	Open	Open
Fwd/Rev Ranges	No Function	Ext 3 Ranges	Ext 3 Ranges		Forward 3 range	Open	Open	Open
Fwd/Rev Ranges	No Function	Ext 3 Ranges	Ext 3 Ranges		Reverse 1 range	Open	Open	Closed
Fwd/Rev Ranges	No Function	Ext 3 Ranges	Ext 3 Ranges		Reverse 2 range	Short	Open	Closed
Fwd/Rev Ranges	No Function	Ext 3 Ranges	Ext 3 Ranges		Reverse 3 range	Open	Short	Closed
No Function	Fwd/Rev Ranges	Ext 3 Ranges	Ext 3 Ranges	External forward/reverse 4 ranges	Forward 1 range	Open	Open	Open
No Function	Fwd/Rev Ranges	Ext 4 Ranges	Ext 4 Ranges		Forward 2 range	Short	Open	Open
No Function	Fwd/Rev Ranges	Ext 4 Ranges	Ext 4 Ranges		Forward 3 range	Open	Short	Open
No Function	Fwd/Rev Ranges	Ext 4 Ranges	Ext 4 Ranges		Forward 4 range	Short	Short	Open
No Function	Fwd/Rev Ranges	Ext 4 Ranges	Ext 4 Ranges		Reverse 1 range	Open	Open	Closed
No Function	Fwd/Rev Ranges	Ext 4 Ranges	Ext 4 Ranges		Reverse 2 range	Short	Open	Closed
Ext 2 Answer	No Function	Ext 2 Ranges	No Function	External forward 2 ranges, with answerback	Forward 1 range	Open	Open	Open
Ext 2 Answer	No Function	No Function	Ext 2 Ranges		Forward 2 range	Short	Open	Closed
No Function	Ext 2 Answer	Ext 2 Ranges	No Function		Forward 1 range	Open	Short	Open
No Function	Ext 2 Answer	No Function	Ext 2 Ranges		Forward 2 range	Short	Short	Closed
Ext 3 Answer	Ext 3 Answer	Ext 3 Ranges	Ext 3 Ranges	External forward 3 ranges, with answerback	Forward 1 range	Open	Open	Open
Ext 3 Answer	Ext 3 Answer	Ext 3 Ranges	Ext 3 Ranges		Forward 2 range	Short	Open	Closed
Ext 3 Answer	Ext 3 Answer	Ext 3 Ranges	Ext 3 Ranges		Forward 3 range	Open	Short	Open
Ext 4 Answer	Ext 4 Answer	Ext 4 Ranges	Ext 4 Ranges	External forward 4 ranges, with answerback	Forward 1 range	Open	Open	Open
Ext 4 Answer	Ext 4 Answer	Ext 4 Ranges	Ext 4 Ranges		Forward 2 range	Short	Open	Closed
Ext 4 Answer	Ext 4 Answer	Ext 4 Ranges	Ext 4 Ranges		Forward 3 range	Open	Short	Open
Ext 4 Answer	Ext 4 Answer	Ext 4 Ranges	Ext 4 Ranges		Forward 4 range	Short	Short	Closed
Fwd/Rev Ranges	Ext 2 Answer	Ext 2 Ranges	No Function	External forward/reverse 2 ranges, with answerback	Forward 1 range	Open	Open	Open
Fwd/Rev Ranges	Ext 2 Answer	Ext 2 Ranges	No Function		Forward 2 range	Short	Open	Closed
Fwd/Rev Ranges	Ext 2 Answer	No Function	Ext 2 Ranges		Reverse 1 range	Open	Open	Closed
Fwd/Rev Ranges	Ext 2 Answer	No Function	Ext 2 Ranges		Reverse 2 range	Short	Short	Closed
Ext 2 Answer	Fwd/Rev Ranges	Ext 2 Ranges	No Function	External forward/reverse 2 ranges, with answerback	Forward 1 range	Open	Open	Open
Ext 2 Answer	Fwd/Rev Ranges	Ext 2 Ranges	No Function		Forward 2 range	Short	Open	Closed
Ext 2 Answer	Fwd/Rev Ranges	Ext 2 Ranges	No Function		Reverse 1 range	Open	Open	Closed
Ext 2 Answer	Fwd/Rev Ranges	Ext 2 Ranges	No Function		Reverse 2 range	Short	Short	Closed
Ext 2 Answer	Fwd/Rev Ranges	No Function	Ext 2 Ranges	External forward/reverse 2 ranges, with answerback	Forward 1 range	Open	Open	Open
Ext 2 Answer	Fwd/Rev Ranges	No Function	Ext 2 Ranges		Forward 2 range	Short	Open	Closed
Ext 2 Answer	Fwd/Rev Ranges	No Function	Ext 2 Ranges		Reverse 1 range	Open	Open	Closed
Ext 2 Answer	Fwd/Rev Ranges	No Function	Ext 2 Ranges		Reverse 2 range	Short	Short	Closed

*: "No Function" is the default value. Only SI1 or SI2 terminals are used for single or dual ranges; accordingly, the unused terminal remains at the default value (i.e., No Function) and can therefore be used for other functions.

Parameter setting sequence (for multiple ranges switching via external status input)

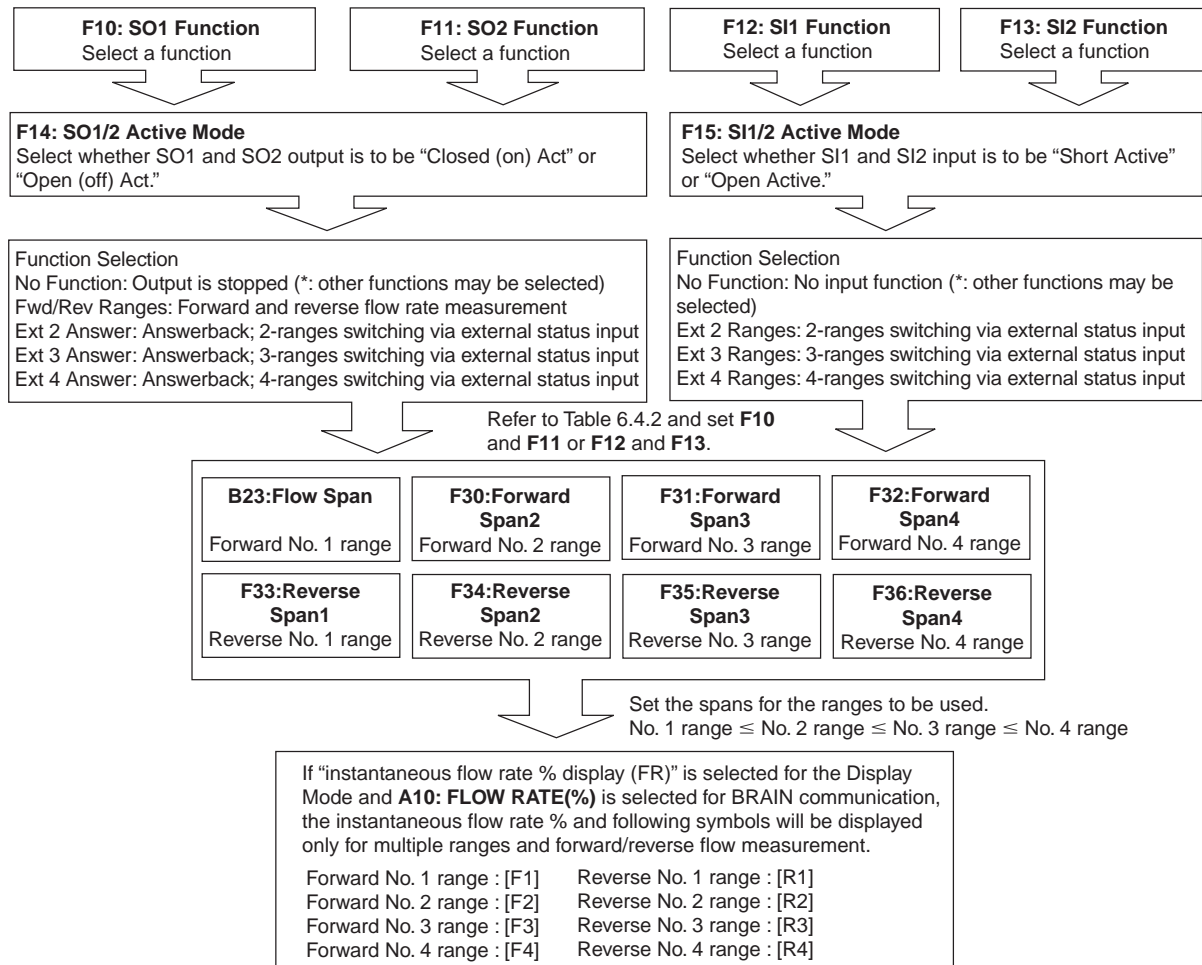

F0609.EPS

[F40: Auto Range Hys] Setting of automatic range-switching hysteresis width

Automatic switching takes place for multiple ranges switching when 100% of the range is exceeded, and this parameter allows a hysteresis width to be set for this switching.

Refer to Figure 6.4.1: Multiple Ranges and Hysteresis Widths.

[F41: Bi Direction Hys] Setting of forward/reverse flow measurement hysteresis width

This parameter sets the hysteresis for forward/reverse flow rate measurement as a % value of the minimum flow span.

Refer to Figure 6.4.1: Multiple Ranges and Hysteresis Widths.

(6) Menu G: Alarm Setting items

(Refer to Section 6.5: Alarm Functions for more details.)

Menu G principally contains setting items relevant to alarms.

[G10: Low Alarm] Low alarm setting

This parameter sets the low limit (L) alarm value, and this is done using a % value of the maximum span.

- A setting value of -110% indicates that the alarm is disabled.

[G11: High Alarm] High alarm setting

This parameter sets the high limit (H) alarm value, and this is done using a % value of the maximum span.

- A setting value of 110% indicates that the alarm is disabled.

[G12: Low Low Alarm] Low-low alarm setting

This parameter sets the low-low limit (LL) alarm value, and this is done using a % value of the maximum span.

- A setting value of -110% indicates that the alarm is disabled.

[G13: High High Alarm] High-high alarm setting

This parameter sets the high-high limit (HH) alarm value, and this is done using a % value of the maximum span.

- A setting value of 110% indicates that the alarm is disabled.



NOTE

Setting of -110% or 110% results in the corresponding function being disabled; accordingly, settings can be combined to implement only high alarms or low alarms, etc.

Output Example 1

The high-high alarm (HH) is set to 90% or more of the flow rate span; the low-low alarm (LL), to 20% or less; the high alarm (H), to 80% or more; and the low alarm (L), to 30% or less.

Settings are:

- G10: Low Alarm = 30%**
- G11: High Alarm = 80%**
- G12: Low Low Alarm = 20%**
- G13: High High Alarm = 90%**

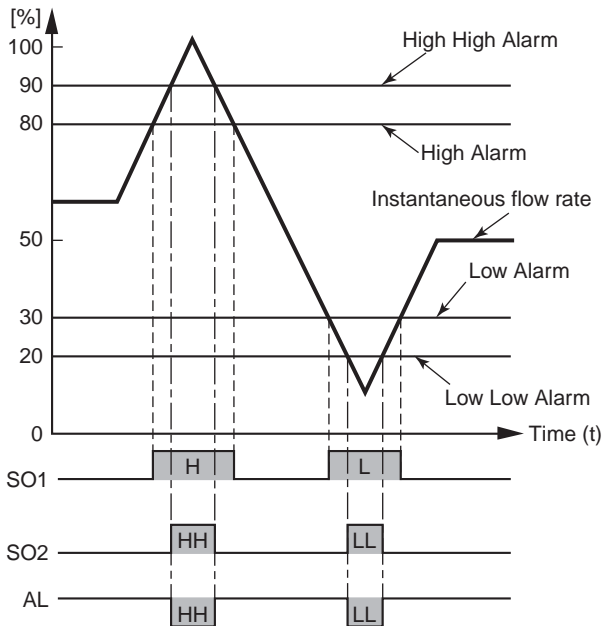

Select "H/L Alarm" for **F10: SO1 Function**
 Select "HH/LL Alarm" for **F11: SO2 Function**
 Select "Closed (On) Act" for **F14: SO1/2 Active Mode**
 Select "Open (Off) Act" for **G20: Alm Out Act Mode**
 Select "Yes" for **G33: Alm-HH/LL**

F0610.EPS

Output Example 2

The high alarm (H) is set to 80% or more of the flow rate span; the low-low alarm (LL), to 20% or less.

Settings are:

- G10: Low Alarm = -110%**
- G11: High Alarm = 80%**
- G12: Low Low Alarm = 20%**
- G13: High High Alarm = 110%**

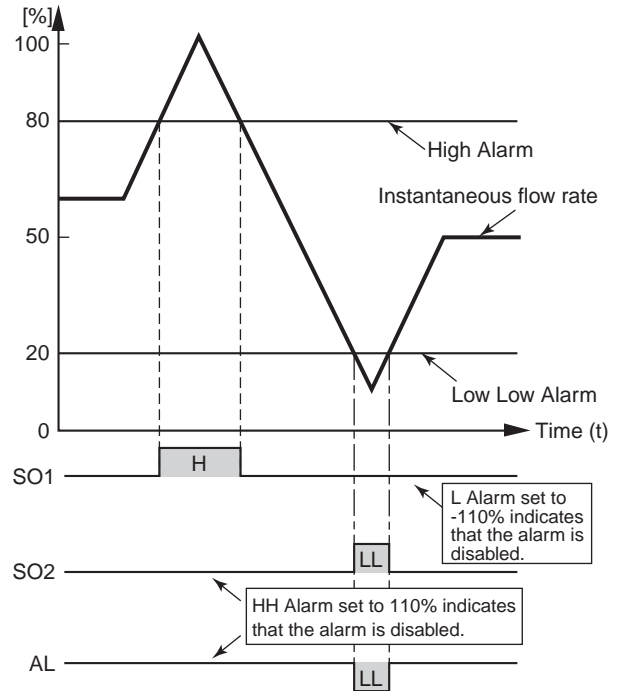

Select "H/L Alarm" for **F10: SO1 Function**
 Select "HH/LL Alarm" for **F11: SO2 Function**
 Select "Closed (On) Act" for **F14: SO1/2 Active Mode**
 Select "Open (Off) Act" for **G20: Alm Out Act Mode**
 Select "Yes" for **G33: Alm-HH/LL**

F0611.EPS

Output Example 3

The high alarm (H) is set to 80% or more of the flow rate span; the high-high alarm (HH), to 90% or more.

Settings are:

- G10: Low Alarm = -110%**
- G11: High Alarm = 80%**
- G12: Low Low Alarm = -110%**
- G13: High High Alarm = 90%**

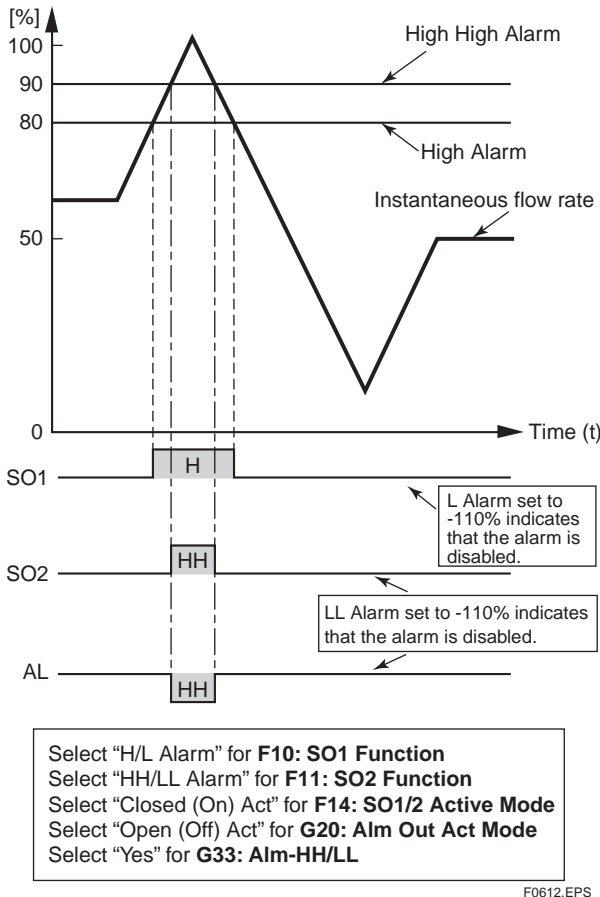

NOTE

- Although the same items can be selected using the SO1 output terminal (selected for **F10**) and the SO2 output terminal (selected for **F11**), output is identical for both.
- Setting values of -110% and 110% are used to disable corresponding functions; and accordingly, status output can be customized for specific purposes.

[G14: H/L Alarm Hys] Setting of upper/lower alarm value hysteresis width

This parameter sets the hysteresis width for upper and lower alarm value, using a % value of the maximum span.

Output Example

The hysteresis width is set to 5%.

Settings are:

- G10: Low Alarm = 30%**
- G11: High Alarm = 80%**
- G12: Low Low Alarm = 20%**
- G13: High High Alarm = 90%**
- G14: H/L Alarm Hys = 5%**

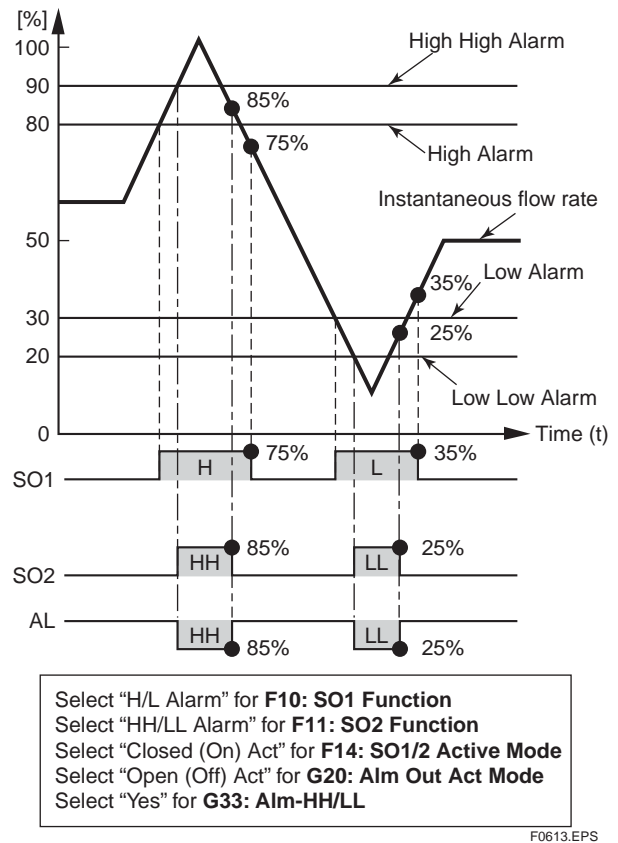

[G20: Alm Out Act Mode] Setting of the active mode for the alarm output.

This parameter selects the active mode for the alarm output terminal.

Setting	Function
Closed (On) Act	When an alarm occurs, alarm output becomes "Closed (On)."
Open (Off) Act	When an alarm occurs, alarm output becomes "Open (Off)."

T0631.EPS

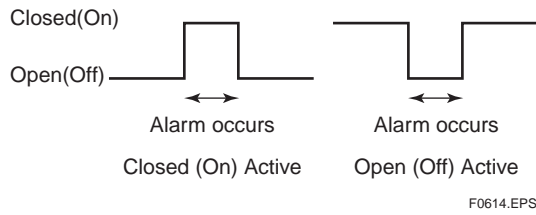
Example

[G21: 4-20mA Alarm Out] Setting of the current output during an alarm occurrence

This parameter can be used to set up the current output during alarm occurrence in advance.

Setting	Function
2.4mA or Less	Fixed at 2.4 mA or less
4.0mA	Fixed at 4 mA
Hold	Fixed current value when an alarm occurred.
21.6mA or More	Fixed at 21.6 mA or more

T0632.EPS

[G22: 4-20mA Burn Out] Display of the current output during a CPU failure

This parameter displays the current output direction for a CPU failure (i.e., burnout). Note that communication will not be possible if such a failure occurs.

With the standard specification, this is set to High and 25mA is output when a failure occurs. Low is setup for optional code C1, and in such a case, 0mA is output when a failure occurs.

**NOTE**

The current output direction for a CPU failure (i.e., burnout) can be changed. Refer to selection 10.2.1: Setting of Burnout Switch.

[G30: Alm-Setting] Alarm recognition of “Setting Alarm”

This parameter specifies whether the setting alarm will be recognized as an alarm.

Setting	Function
No	Not recognized as an alarm
Yes	Recognized as an alarm

T0633.EPS

[G31: Alm-Sig Over] Alarm recognition of “Signal Overflow Alarm”

This parameter specifies whether the signal overflow in process alarms will be recognized as an alarm. A signal overflow occur when there is an error in the input signal.

Setting	Function
No	Not recognized as an alarm
Yes	Recognized as an alarm

T0634.EPS

[G32: Alm-Emp Pipe] Alarm recognition of “Empty Pipe Alarm”

This parameter specifies whether the empty pipe (flowtube is not filled with fluid) in process alarms will be recognized as an alarm.

Setting	Function
No	Not recognized as an alarm
Yes	Recognized as an alarm

T0635.EPS

[G33: Alm-HH/LL] Alarm recognition of “HH/LL Alarm”

(Refer to the descriptions of **G12** and **G13** for more details regarding HH and LL alarms.)

This parameter specifies whether HH/LL alarm in process alarms will be recognized as an alarm.

Setting	Function
No	Not recognized as an alarm
Yes	Recognized as an alarm

T0636.EPS

**NOTE**

To set “HH/LL Alarm” as an alarm, it is necessary to set “HH/LL Alarm” according to **F10: SO1 Function** or **F11: SO2 Function**, and set **G12: Low Low Alarm** or **G13: High High Alarm** as well.

[G34: Alm-Adhesion] Alarm recognition of “Adhesion Alarm”

This parameter specifies whether the electrode adhesion alarm in process alarms will be recognized as an alarm.

Setting	Function
No	Not recognized as an alarm
Yes	Recognized as an alarm

T0636-1.EPS

**NOTE**

The AXFA11 has three different types of alarm (i.e., system alarms, process alarms and setting alarms). For setting alarms and process alarms, settings are made with **G30**, **G31**, **G32**, **G33** and **G34** to specify whether these will be recognized as an alarm.

Refer to Section 6.5: Alarm Functions for more details regarding the content of each alarm and the effect of alarm recognition on output.

[G40: Operation Time] Display of operation time
 This parameter is used to display the operation time. The operation time is the total time that is counted while the device works actually. When the power supply is off, the operation time is not counted.
 For example, “1D23:45” indicates an operation time of 1 day, 23 hours, and 45 minutes.

[G41: Alm Record1] Alarm record1
 This parameter is used to display the most-recent alarm, and the alarms that can be displayed are as follows.

Alarm Items

Item	Description
: 16 space characters (i.e., no display)	No issuing of alarms
10 : uP Fault	Microprocessor (CPU) failure
11 : EEPROM Fault	EEPROM failure
12 : A/D(H) Fault	A/D converter failure (at high frequency side)
13 : A/D(L) Fault	A/D converter failure (at low frequency side)
14 : A/D(Z) Fault	A/D converter failure (detection of adhesion)
15 : Coil Open	Flowtube coil is open-circuit
16 : EEPROM Dflt	EEPROM returns to default values
18 : Power off	Power supply is off.
19 : Inst Pwr Fail	Instantaneous power fail for tens of milliseconds. After this fail is released, outputs reach the previous value immediately.
28 : WDT	The return from excessive instantaneous noise. After the noise is released, output return the normal condition.
30 : Sig Overflow	Input signal error
31 : Empty Pipe	Flowtube is not filled with fluid
33 : Adhesion Alm	Insulation adhered to electrode

T0637.EPS



NOTE

Records for “30: Sig Overflow” are kept only when **G31** specifies that this condition is to be recognized as an alarm (i.e., “Yes” is selected). Records for “31: Empty Pipe” are kept only when **G32** specifies that this condition is to be recognized as an alarm (i.e., “Yes” is selected). Records for “33: Adhesion Alm” are kept only when **G34** specifies that this condition is to be recognized as an alarm (i.e., “Yes” is selected).

[G42: Alm Record Time1] Display the operation time of alarm record1
 This parameter is used to display the operation time at which the alarm indicated by **G41: Alm Record1** was occurred. For example, “1D23:45” indicates that an alarm was occurred at the operation time of 1 day, 23 hours, and 45 minutes.

[G43: Alm Record2] Alarm record2
 This parameter is used to display the second most-recent alarm, and the alarms that can be displayed are the same as those for **G41: Alm Record1**.

[G44: Alm Record Time2] Display the operation time of alarm record2
 This parameter is used to display the operation time at which the alarm indicated by **G43: Alm Record2** was occurred. For example, “1D23:45” indicates that an alarm was occurred at the operation time of 1 day, 23 hours, and 45 minutes.

[G45: Alm Record3] Alarm record3
 This parameter is used to display the third most-recent alarm, and the alarms that can be displayed are the same as those for **G41: Alm Record1**.

[G46: Alm Record Time3] Display the operation time of alarm record3
 This parameter is used to display the operation time at which the alarm indicated by **G45: Alm Record3** was occurred. For example, “1D23:45” indicates that an alarm was occurred at the operation time of 1 day, 23 hours, and 45 minutes.

[G47: Alm Record4] Alarm record4
 This parameter is used to display the fourth most-recent alarm, and the alarms that can be displayed are the same as those for **G41: Alm Record1**.

[G48: Alm Record Time4] Display the operation time of alarm record4
 This parameter is used to display the operation time at which the alarm indicated by **G47: Alm Record4** was occurred. For example, “1D23:45” indicates that an alarm was occurred at the operation time of 1 day, 23 hours, and 45 minutes.

(7) Menu H: Display Setting items

Menu H contains setting items relevant to the display unit.

[H10: Display Select1] Setting of the first line for display unit

→ Refer to the description for parameter **B40**
 This parameter selects the display content of the first line for display unit.

[H11: Display Select2] Setting of the second line for display unit

→ Refer to the description for parameter **B41**

This parameter selects the display content of the second line for display unit.

[H12: Display Select3] Setting of the third line for display unit

→ Refer to the description for parameter **B42**

This parameter selects the display content of the third line for display unit.

[H20: Display Cycle] Setting of the display cycle

This parameter sets the cycle for the display-response speed of display unit. Settings should be made in accordance with the measurement environment by, for example, setting a longer display cycle when using the equipment in low temperatures.

[H30: Language] Selection of language used for the display unit.

→ Refer to the description for parameter **B10**

This parameter can be used to select the language for display unit.

(8) Menu J: Auxiliary Function Setting items

Menu J contains setting items such as the flow direction, rate limits, and current output limits.

[J10: 4-20mA Low Cut] Setting of the low-cut range for current output.

This parameter is used to force current output to 0% (i.e., 4mA) in the vicinity of 0% and setting for the current (4 to 20mA) output low cut is made using a percentage of the smallest flow rate span. However, the low cut function will be terminated if this parameter is set to 0%.

The indications of the instantaneous flow rates (% , Actual instantaneous flow rate, mA, Bar graph) on the display unit are the same action.

Example: Situation where low cut is set to 10%

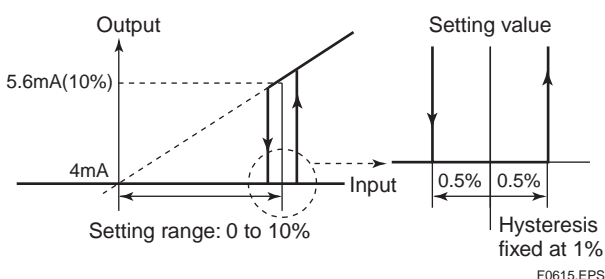

[J11: 4-20mA Low Lmt] Setting of the low limit for current output

This parameter is used to restrict low current portions of current (4 to 20mA) output, and it is initially set to -20%. Setting should be performed when a higher

value is required for the lower limit.

The indications of the instantaneous flow rates (% , Actual instantaneous flow rate, mA, Bar graph) on the display unit are the same action.

Example: Situation where low limit is set to 10%

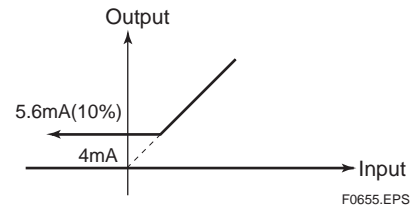

NOTE

If "2.4mA or less" has been set for **G21:4-20mA Alarm Out**, 2.4mA or less will be output upon an alarm occurrence, regardless of the low limit setting.



NOTE

- If the setting value for the low limit is not less than the high limit value (as set using **J12: 4-20mA High Lmt**), the setting alarm "4-20 Lmt Err" will be displayed.
- This parameter has no effect on pulse output or the totalization function.

[J12: 4-20mA High Lmt] Setting of the high limit for current output

This parameter is used to restrict high current portions of current (4 to 20mA) output, and it is initially set to 120%. Setting should be performed when a lower value is required for the higher limit.

The indications of the instantaneous flow rates (% , Actual instantaneous flow rate, mA, Bar graph) on the display unit are the same action.

Example: Situation where high limit is set to 90%

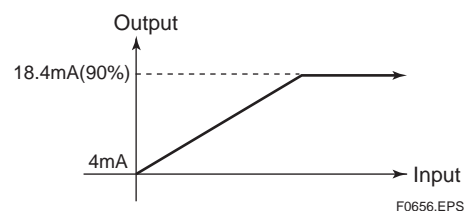

NOTE

If "21.6mA or more" has been set for **G21:4-20mA Alarm Out**, 21.6mA or more will be output upon an alarm occurrence, regardless of the high limit setting.

[J20: Flow Direction] Setting of the flow direction
Upon shipment from the manufacturing plant, the system is setup such that flow in the same direction, as shown by the direction of the arrow mark on the flowtube, will be measured as forward flow; however, this parameter can be used to set “Reverse” so that flow in the opposite direction to the arrow mark will be treated as forward.

Note: This function does not apply to measurement in both the forward and reverse directions, although this can be setup using by selecting “Fwd/Rev Ranges” from either **F10: SO1**

Function or

Setting	Function
Forward	Forward direction corresponds with arrow mark
Reverse	Forward direction is opposite to arrow mark

T0638.EPS

[J21: Rate Limit] Setting of the rate limit value

- This parameter is used in situations where sudden noise cannot be eliminated by increasing the damping time constant.
- In situations where step signals or sudden noise signals caused by slurries or the like are entered, this parameter is used to set the standard for determining whether an input corresponds to a flow measurement or noise. Specifically, this determination is made using upper and lower rate limits and using the dead time.
- Rate limit values are set using a percentage of the smallest range. The range of deviation per one calculation cycle should be input.

[J22: Dead Time] Setting of dead time

This parameter sets the time for application of the rate limit, and if a value of 0 is set, the rate limit function will be terminated.



NOTE

Determining rate limit value and dead time

Rate limit value:
Determines the level for output fluctuation cutoff. For example, if this is set to 2%, noise above 2% will be eliminated as shown in the diagram.

Dead time (T₀):
This is to be determined using the output fluctuation width. If noise exceeds the dead time as shown in the diagram below, the dead time should be made longer.

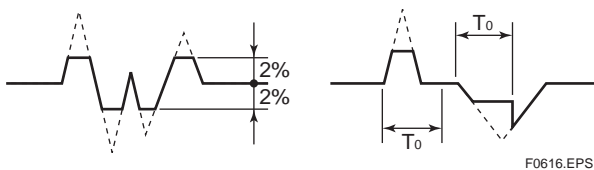

F0616.EPS

● Signal processing method:

A fixed upper and lower limit value is setup with respect to the primary delay response value for the flow rate value obtained during the previous sampling, and if the currently sampled flow rate is outside these limits, then the corresponding limit is adopted as the current flow rate value. In addition, if signals which breach the limits in the same direction occur over multiple samples (i.e., within the dead time), it is concluded that the corresponding signal is a flow rate signal.

Example 1: Step input

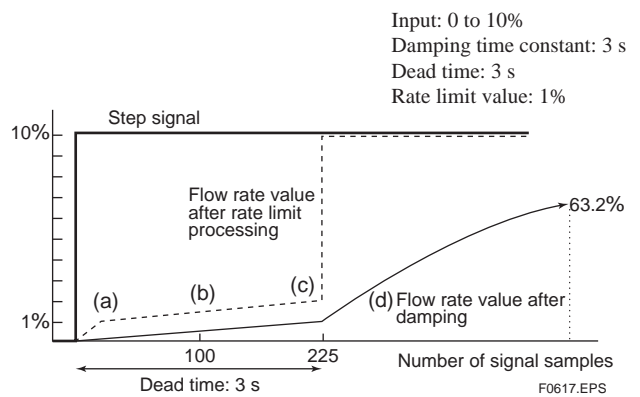

- (1) In comparison with the previous value at (a), it is determined that the signal is in excess of the rate limit value and the response becomes 1%. However, the actual output applies damping, and therefore the output turns out to be as indicated by the solid line.
- (2) Subsequent flow values within the dead time zone correspond to signals of post-damping flow value + rate limit value (1%).
- (3) Since input signals do not return to within the rate limit value during the dead time, it is determined at (c) that this signal is a flow rate signal.
- (4) The output signal becomes a damped curve and compliance with the step signal begins.

Three seconds after determination of a flow rate signal in the above figure, a level of 63.2% is reached.

Example 2: Slurry noise

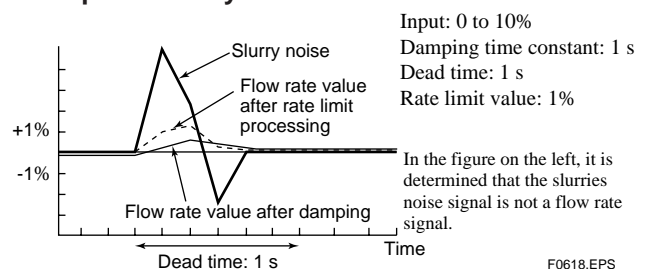

[J23: Pulsing Flow] Selection of pulsing flow support
In a situation where pulsating flow causes error in the average flow value, due to the application of a plunger pump, this parameter provides functionality whereby calculation is controlled and variations in flow rate are followed.

Setting	Function
No	Normal
Yes	Support for pulsing flow

T0639.EPS

[J24: T/P Damp Select] Setting of damping operation
This parameter is used to select that the flow rate value obtained through damping calculation for totalization and pulse output or the instantaneous flow rate value (no damping) for totalization and pulse output.

Setting	Function
Damp	Damping
No Damp	No damping

T0640.EPS

[J30: Power Synch] Setting of power synchronization
This parameter selects whether or not the internal frequency is to be synchronized with that of the power supply.

Setting	Function
No	Not synchronized
Yes	Synchronized

T0641.EPS

[J31: Power Frequency] Setting of power frequency
When “Yes” (i.e., in synchrony) has been selected for **J30: Power Synch**, this parameter is used to display the power supply frequency. If “No” (i.e., not synchronized) has been selected, the power supply frequency is to be specified.

**IMPORTANT**

In situations where a DC power supply is used for converters, set the local commercial power frequency in area where the converter is installed (size 2.5mm to 1000mm). Set “No” for **J30: Power Synch** and the local commercial power frequency for **J31: Power Frequency**.

**IMPORTANT**

In situations where AXFA11 is combined with a remote flowtube the size of 1100 mm (44 in.) to

2600 mm (104 in.), set the fixed frequency (49.00 Hz) in case that either AC or DC power supplies is used for converters.
Set “No” for **J30: Power Synch** and “49.00” for **J31: Power Frequency**.

Following settings are necessary by power supply and by flow tube size.

Power Supply Code 1**(100 to 240 V AC or 100 to 120 V DC)**

		Size 2.5 mm (0.1 in.) to 1000 mm (40 in.)	Size 1100 mm (44 in.) to 2600 mm (104 in.)
AC power supply	J30	Power synchronous (Yes)	Power asynchronous (No)
	J31	No setting	49.00 Hz
DC power supply	J30	Power asynchronous (No)	Power asynchronous (No)
	J31	Local commercial power frequency	49.00 Hz

T0642-1.EPS

Power Supply Code 2 (24 V AC/DC)

		Size 2.5 mm (0.1 in.) to 1000 mm (40 in.)	Size 1100 mm (44 in.) to 2600 mm (104 in.)
AC power supply	J30	Power asynchronous (No)	Power asynchronous (No)
	J31	Local commercial power frequency	49.00 Hz
DC power supply	J30	Power asynchronous (No)	Power asynchronous (No)
	J31	Local commercial power frequency	49.00 Hz

T0642-2.EPS

[J40: Memo 1] Setting of memo 1**[J41: Memo 2]** Setting of memo 2**[J42: Memo 3]** Setting of memo 3

These parameters are used with the memo function, and up to 16 characters can be set for each.

[J50: Software Rev No] Display of software revision

This parameter is used to display the software’s revision number.

(9) Menu K: Diagnostic Function Setting items

Menu K contains items that are relevant to the diagnosis of insulation adhesion to the electrode.

[K10: Adhesion Check] Setting of adhesion diagnostic function

This parameter selects whether or not the adhesion diagnostic function will be carried out.

Setting	Function
No	Halt the adhesion diagnostic function
Yes	Carry out the adhesion diagnostic function

T0642.EPS

**NOTE****Adhesion Diagnostic Function**

- This function diagnose adhesion using electrode resistance values.
- When “Adhesion check” has been set for **B41/H11: Display Select 2** or **B42/H12: Display Select 3**, the diagnose adhesion is indicated on the display unit using four different levels.
- If the judgment value for Level 3 is exceeded, a warning is displayed; and if the value for Level 4 is exceeded, an alarm is displayed.
- Available conductivity for this function is limited to:
 - Nominal size 10 mm or smaller: 30 $\mu\text{S}/\text{cm}$
 - Nominal size 15 mm or larger: 10 $\mu\text{S}/\text{cm}$
 Make sure to use the adhesion diagnostic function with the greater conductivity than the above mentioned value.



[K11: Adhesion Level1] Setting the resistance value for adhesion level 1.

This parameter sets the resistance value (in M ohm) for judgment of Level 1.

[K12: Adhesion Level2] Setting the resistance value for adhesion diagnostic level 2.

This parameter sets the resistance value (in M ohm) for judgment of Level 2.

[K13: Adhesion Level3] Setting the resistance value for adhesion diagnostic level 3.

This parameter sets the resistance value (in M ohm) for judgment of Level 3.

*: The warning **80: Adhesion Wng** is displayed when the adhesion level reaches Level 3.

*: If “Warning Output” has been selected for **F10: SO1 Function** or **F11: SO2 Function**, then status output will be performed when the adhesion level reaches Level 3.

[K14: Adhesion Level4] Setting the resistance value for adhesion diagnostic level 4.

This parameter sets the resistance value (in M ohm) for judgment of Level 4.

*: The process alarm **33: Adhesion Alm** is displayed when the adhesion level reaches Level 4.

*: Alarm output will be performed if “Yes” has been selected for **G34: Alm-Adhesion**.

[K15: Adh Measure Value] Displays the resistance value for adhesion diagnose

This parameter displays the value measured using the adhesion diagnostic function (in M ohm).

When “No” is selected for **K10: Adhesion Check**, this parameter displays the indetermination value.

(10) Menu M: Automatic Zero Adjustment Function Setting items

Menu M contains items that are relevant to automatic adjustment of the zero point.

[M10: Auto Zero Exe] Execution of automatic zero adjustment function

→ Refer to the description of parameter **B50**.

[M11: Magflow Zero] Results of automatic zero adjustment

This parameter is used to display the results obtained from **B50/M10: Auto Zero Exe**. Specifically, the correction value displayed, and it is also possible to directly enter correction value.

(11) Menu N: Loop Test Setting items

Menu N contains items that are relevant to loop testing.

[N10: Test Mode] Setting for loop test execution

Setting	Function
Normal	No execution of loop testing
Test	Loop testing is started

T0644.EPS

**IMPORTANT**

- (1) Test output has priority over flow rate measurement signals. When carrying out flow rate measurements, be sure to always return to “Normal”.
- (2) Upon entry to the Test Mode, all output terminals will simultaneously adopt test condition.

- (3) "Normal" will be restored when the power is turned off or when 30 minutes have elapsed since entry to Test Mode.
- (4) In Test Mode, the warning **83: Fix Cur Wng** will be displayed as a warning message. (For more details, refer to Section 6.5 Alarm Functions.)

[N11: Test Output Value] Setting for test output values

During loop testing, current output (4 to 20mA), totalization, and pulse will be output in accordance with this parameter's setting, and values can be set when "Test" has been selected for **N10: Test Mode**. With multiple ranges or when performing forward/reverse flow measurements, setting should be done using a percentage of the maximum range.

[N20: Test SO1] Setting for SO1 output terminal condition during testing

This parameter sets the condition of the SO1 status output terminal during loop testing. Setting is possible when "Test" has been selected for **N10: Test Mode**.

Setting	Function
Open (Off)	SO1 output terminal in Open (Off) condition
Closed (On)	SO1 output terminal in Closed (On) condition

T0645.EPS

[N21: Test SO2] Setting for SO2 output terminal condition during testing

This parameter sets the condition of the SO2 status output terminal during loop testing. Setting is possible when "Test" has been selected for **N10: Test Mode**.

Setting	Function
Open (Off)	SO2 output terminal in Open (Off) condition
Closed (On)	SO2 output terminal in Closed (On) condition

T0645-2.EPS

[N22: Test Alarm Out] Setting for alarm terminal condition during testing

This parameter sets the condition of the alarm output terminal (AL) during loop testing.

Setting	Function
Open (Off)	AL output terminal in Open (Off) condition
Closed (On)	AL output terminal in Closed (On) condition

T0645-3.EPS

[N23: Test SI1] Display for SI1 status input terminal condition during testing

This parameter is used to display the condition of the SI1 status input terminal during loop testing.

Setting	Function
Open	SI1 input terminal in Open condition
Short	SI1 input terminal in Short condition

T0646.EPS

[N24: Test SI2] Display for SI2 status input terminal condition during testing

This parameter is used to display the condition of the SI2 status input terminal during testing.

Setting	Function
Open	SI2 input terminal in Open condition
Short	SI2 input terminal in Short condition

T0646-2.EPS

(12) Menu P: Parameter Protection items

Menu P contains items that are relevant to write protection and passwords.

[P10: Key Code] Parameter of the display restriction
This parameter restricts access to the Service Mode.



NOTE

Write Protect function

- The parameters **P20** through **P23** are set when using the write protect function. Specifically, this function responds to a hardware switch or the setting of a software password, and it protects parameters from being overwritten.
- If the hardware switch is set to "Protect", it will not be possible to overwrite parameters; furthermore, this condition will be maintained until the switch is set to "Enable".
- For more details regarding hardware switch settings, refer to Section 10.2.2: Setting of Write Protect Switch.

[P20: Write Protect] Status indication for write protection

This parameter is used to indicate whether or not write protection is currently on.

Default setting (Enable)

P20:Write Protect No

F0620.EPS

Write protection (Protect)

P20:Write Protect Yes

F0621.EPS

[P21: Enable Wrt Passwd] Setting of password to release the write protection function

When the correct password is input, write protection will be released for a period of 10 minutes; furthermore, this period will be extended by a further 10 minutes each time a parameter is overwritten.

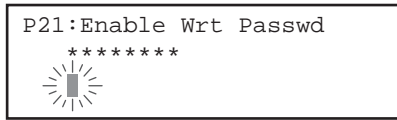

F0622.EPS

The cursor will flash when entering Parameter Replacement Mode, and the password set with **P22: New Password** should be input at this time.

[P22: New Password] Setting of a new password
This parameter sets the password required for the release of write protection. When set, it will be possible to make write protect settings on the software side.

Default setting

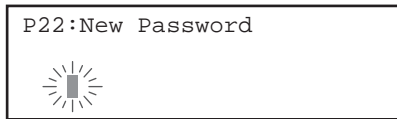

F0623.EPS

The default setting for this parameter is a string of 8 spaces (i.e., Enable), and thus, the password field will be empty. When the cursor is flashing, the password should be input. Press the SET key twice to confirm the password. The display will then change to “*****”.

After password setting

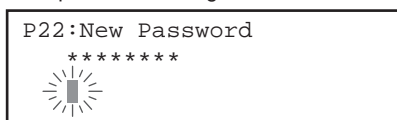

F0624.EPS

To change a password, first of all use the password originally set with **P21: Enable Wrt Passwd** to release the write protect function, and then set the new password. Alternatively, if it is desired to return to the condition where no password is set, enter a string of 8 spaces.

[P23: Software Seal] Display the software seal
When the joker password has been used to release write protection, this parameter displays “Break”, and when protection is cancelled using the password set using **P22: New Password**, it returns to “Keep”.



NOTE

If you should forget your password, the joker password can be used to temporarily release write protection function. To obtain the joker password, please contact your nearest YOKOGAWA sales office.

6.5 Alarm Functions

6.5.1 Alarm Levels

Alarms are classified into the following four different types based on level.

Alarm	Level	Description
System alarm	Major breakdown	Device breakdown or inability to obtain correct measurements. Replacement will be required.
Process alarm	Intermediate level breakdown	Device is normal but process-related errors make correct measurement impossible. Maintenance or the like will be required.
Setting alarm	Minor breakdown	Device is normal but errors have been made in the setting of parameters. Functions not related to the incorrect settings are operating normally. The incorrect settings must be corrected.
Warning	Warning	Device and measurements are normal but a warning is occurred.

T0647.EPS

When an alarm has been occurred, the corresponding alarm name, description, and suitable countermeasure will be displayed on the display unit. The normal Display Mode and Alarm Mode may be displayed alternatively. When a warning has been issued, the corresponding content will be shown in the third line in the Display Mode.

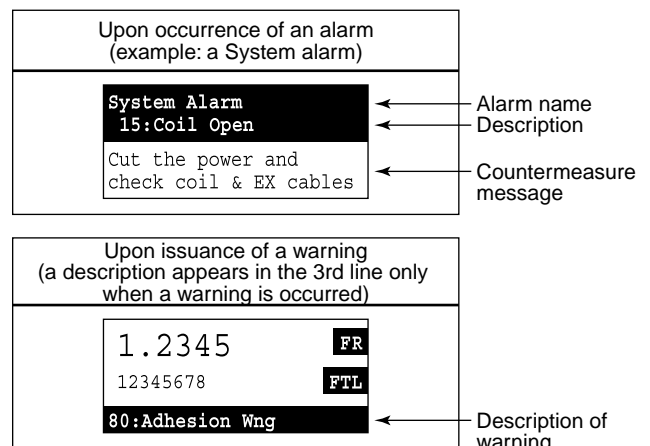

F0625.EPS

6.5.2 Alarm Selection

The display and output differs depending on the alarm levels. Certain types of alarm may or may not be recognized as alarms, according to the settings of certain parameters. The parameters that are relevant to this function as follows.

[G20: Alm Out Act Mode] Setting of the active mode for the alarm output

[G21: 4-20mA Alarm Out] Setting of the current output during an alarm occurring.

[G30: Alm-Setting] Alarm recognition of “Setting Alarm”

[G31: Alm-Sig Over] Alarm recognition of “Signal Overflow Alarm”

[G32: Alm-Emp Pipe] Alarm recognition of “Empty Pipe alarm”

[G33: Alm-HH/LL] Alarm recognition of “HH/LL Alarm” (Refer to the descriptions of **G12** and **G13** for more details regarding HH and LL alarms.)

[G34: Alm-Adhesion] Alarm recognition of “Adhesion Alarm”

[G41: Alm Record1] Alarm record1

[G43: Alm Record2] Alarm record2

[G45: Alm Record3] Alarm record3

[G47: Alm Record4] Alarm record4

(1) Display and output condition for system alarms

		Alarm description	Alarm output	4-20 mA output	Totalization	Pulse	Display unit	Alarm record
	Normal		Closed (On)	Normal	Normal	Normal	Display Mode	No
10	μP Fault	Microprocessor(CPU)failure	Open (Off)	0mA or 25mA (*)	Indetermination	Stopped	Indetermination	Indetermination
11	EEPROM Fault	EEPROM failure						
12	A/D(H) Fault	A/D converter failure	Open (Off)	Fixed (G21 selection)	Stopped	Stopped	Alarm Mode (display of system alarm message)	Recorded
13	A/D(L) Fault							
14	A/D(Z) Fault							
15	Coil Open	Flowtube coil is open-circuit						
16	EEPROM Dflt	EEPROM default values						

Note: • Operations are performed in accordance with above table, when “Open (Off) Act” is set for **G20: Alm Out Act Mode**.

• 4-20 mA output upon the occurrence of an alarm will be fixed at the value selected with **G21: 4-20mA Alarm Out**.

*The output value is performed in accordance with the setting of the burnout switch. For information about this switch, see Section 10.2.1.

T0648.EPS

(2) Display and output condition for process alarms

		Alarm description	Selection (parameter number)	Alarm output	4-20 mA output	Totalization	Pulse output	Display unit	Alarm record
30	Sig Overflow	Input signal error	YES (G31)	Open (Off)	Fixed	Stopped	Stopped	Alarm Mode (Message)	Recorded
			NO (G31)	Closed (On)	Continuous (*)	Continuous (*)	Continuous (*)	Display Mode	No
31	Empty Pipe	Flowtube is not filled with fluid	YES (G32)	Open (Off)	Fixed	Stopped	Stopped	Alarm Mode (Message)	Recorded
			NO (G32)	Closed (On)	Continuous (*)	Continuous (*)	Continuous (*)	Display Mode	No
32	HH/LL Alm	HH/LL Alarm	YES (G33)	Open (Off)	Normal operation	Normal operation	Normal operation	Alarm Mode (Message)	No
			NO (G33)	Closed (On)				Display Mode	
33	Adhesion Alm	Electrode adhesion alarm	YES (G34)	Open (Off)	Fixed	Stopped	Stopped	Alarm Mode (Message)	Recorded
			NO (G34)	Closed (On)	Continuous (*)	Continuous (*)	Continuous (*)	Display Mode	No

Note: • Operations are performed in accordance with above table, when “Open (Off) Act” is set for **G20: Alm Out Act Mode**.

• 4-20 mA output upon the occurrence of an alarm will be fixed at the value selected with **G21: 4-20mA Alarm Out**.

*: Although outputs are continuous, output values are not guaranteed.

T0649.EPS

(3) Display and output condition for setting alarm occurrences

		Alarm description	Selection (parameter number)	Alarm output	4-20 mA output	Totalization	Pulse output	Display unit	Alarm record
50	Span > 10m/s	Span flow velocity setting is 11 m/s or more	NO (G30)	Closed (On)	Fixed	Stopped	Stopped	Alarm Mode (message)	No
51	Span < 0.1m/s	Span flow velocity setting is 0.05 m/s or less		Closed (On)	Normal operation	Stopped	Normal operation	Alarm Mode (message)	No
52	TTL>10000p/s	Totalization rate is 11000 pps or more		Closed (On)	Fixed	Normal operation	Normal operation	Alarm Mode (message)	No
53	TTL<0.0001p/s	Totalization rate is 0.00005 pps or less		Closed (On)	Fixed	Stopped	Stopped	Alarm Mode (message)	No
54	4-20 Lmt Err	The condition [4-20 low limit (J11) < 4-20 high limit (J12)] is not satisfied.		Closed (On)	Fixed	Normal operation	Normal operation	Alarm Mode (message)	No
55	Multi Rng Err	The condition [No. 1 range < No. 2 range < No. 3 range < No. 4 range] is not satisfied for multiple ranges.		Closed (On)	Fixed	Stopped	Stopped	Alarm Mode (message)	No
56	H/L HH/LL Set	The condition [High Alarm (G11) – Low Alarm (G10) > H/L Alarm Hys (G14)] or the condition [High High Alarm (G13) – Low Low Alarm (G12) > H/L Alarm Hys (G14)] is not satisfied.		Closed (On)	Normal operation	Normal operation	Normal operation	Alarm Mode (message)	No
57	Dens Set Err	Mass units have been selected for Base Flow Unit (C40) but density is set to 0.		Closed (On)	Fixed	Stopped	Stopped	Alarm Mode (message)	No
60	PLS >10000p/s	Pulse rate is 11000 pps or more with 50% duty selection. Pulse rate is 10000 pps or more with 0.05 ms selection.							
61	PLS > 5000p/s	Pulse rate is 5000 pps or more with 0.1 ms selection.							
62	PLS > 1000p/s	Pulse rate is 1000 pps or more with 0.5 ms selection.							
63	PLS > 500p/s	Pulse rate is 500 pps or more with 1 ms selection.		Closed (On)	Normal operation	Normal operation	Stopped	Alarm Mode (message)	No
64	PLS > 25p/s	Pulse rate is 25 pps or more with 20 ms selection.							
65	PLS > 15p/s	Pulse rate is 15 pps or more with 33 ms selection.							
66	PLS > 10p/s	Pulse rate is 10 pps or more with 50 ms selection.							
67	PLS > 5p/s	Pulse rate is 5 pps or more with 100 ms selection.							
70	PLS<0.0001p/s	Pulse rate is 0.00005 pps or less.							
71	Meas Mod Set	Measure Mode (C20) is set to Enhanced DF without selecting an optional code HF1 or HF2.		Closed (On)	Fixed	Stopped	Stopped	Alarm Mode (message)	No
72	Size Set Err	A value of 3000.1 mm or more is set for Nominal Size (C32).		Closed (On)	Fixed	Stopped	Stopped	Alarm Mode (message)	No
73	Adh Set Err	The condition [Level:1<Level:2<Level:3<Level:4] is not satisfied for adhesion diagnostic level.		Closed (On)	Normal operation	Normal operation	Normal operation	Alarm Mode (message)	No
	Occurring of any alarm from 50 through 73	–	YES (G30)	Open (Off)	Fixed	Stopped	Stopped	Alarm Mode (message)	No

Note: • Operations are performed in accordance with above table, when “Open (Off) Act” is set for **G20: Alm Out Act Mode**.
• 4-20 mA output upon the occurrence of an alarm will be fixed at the value selected with **G21: 4-20mA Alarm Out**.

T0650.EPS

6.5.3 Alarms & Warning Messages

System Alarms (Device breakdown or inability to obtain correct measurements.)			
Display unit/BRAIN (□60) content	Alarm countermeasure message on display unit	Alarm description	Countermeasure
10:uP Fault	Contact nearest office or service center	Microprocessor (CPU) failure	Contact your nearest Yokogawa office or service center.
11:EEPROM Fault	Contact nearest office or service center	EEPROM failure	
12:A/D(H) Fault	Contact nearest office or service center	A/D converter failure	
13:A/D(L) Fault	Contact nearest office or service center		
14:A/D(Z) Fault	Contact nearest office or service center		
15:Coil Open	Cut the power and check coil & EX cable	Flowtube coil is open-circuit	Turn off the AXFA11 power supply and examine the excitation cable for breakage. If there is no breakage, contact your nearest Yokogawa office or service center.
16:EEPROM Dflt	Contact nearest office or service center	EEPROM default values	Contact your nearest Yokogawa office or service center.

T0651.EPS

Process Alarms (Device is normal but process-related errors make correct measurement impossible.)			
Display unit/BRAIN (□60) content	Alarm countermeasure message on display unit	Alarm description	Countermeasure
30:Sig Overflow	Check signal cable and grounding	Input signal error	Carry out an investigation as follows: <ul style="list-style-type: none"> • Check the signal cable for breakage. • Check for contact between signal cable, power cable, and excitation cable. • Check for stray currents in the fluid. • Check the grounding.
31:Empty Pipe	Fill flow tube with fluid	Flowtube is not filled with fluid	Fill the flowtube with fluid.
32:HH/LL Alm	Check the flow rate and setting value	Flow rate alarm for greater than High-High limit value or less than Low-Low limit value.	Check the flow rate and setting value of High High limit and Low Low limit.
33:Adhesion Alm	Clean electrodes	Electrode adhesion alarm	Clean the electrodes.

T0652.EPS

6. PARAMETER DESCRIPTION

Setting Alarms (Device is normal but errors have been made in the setting of parameters.)			
Display unit/BRAIN (□60) content	Alarm countermeasure message on display unit	Alarm description	Countermeasure
50:Span > 10m/s	Check parameter C40, C41, and C42	Span flow velocity setting is 11 m/s or more	Check whether parameters C40, C41, and C42 are correct. In case that multiple range or forward and reverse flow measurement functions is used, check whether parameters F30 through F36 are correct.
51:Span < 0.1m/s	Check parameter C40, C41, and C42	Span flow velocity setting is 0.05 m/s or less	
52:TTL>10000p/s	Check parameter D10 and D11	Totalization rate is 11000 pps or more	Check whether parameters D10 and D11 are correct.
53:TTL<0.0001p/s	Check parameter D10 and D11	Totalization rate is 0.00005 pps or less	
54:4-20 Lmt Err	Check parameter J11 and J12	The condition [4-20 low limit (J11) < 4-20 high limit (J12)] is not satisfied.	Check whether parameters J11 and J12 are correct.
55:Multi Rng Err	Check parameter F30 to F36	The condition [No. 1 range < No. 2 range < No. 3 range < No. 4 range] is not satisfied for multiple ranges.	Check whether parameters F30 through F36 are correct.
56:H/L HH/LL Set	Check parameter G10 to G14	The condition [High Alarm (G11) – Low Alarm (G10) > H/L Alarm Hys (G14)] or the condition [High High Alarm (G13) – Low Low Alarm (G12) > H/L Alarm Hys (G14)] is not satisfied.	Check whether parameters G10 through G14 are correct.
57:Dens Set Err	Check parameter C40, C45, and C46	Mass units have been selected for Base Flow Unit (C40) but density is set to 0.	Check whether parameters C40, C45, and C46 are correct.
60:PLS > 10000p/s	Check parameter E10, E11, and E12	Pulse rate is 11000 pps or more with 50% duty selection. Pulse rate is 10000 pps or more with 0.05 ms selection.	Check whether parameters E10, E11, and E12 are correct.
61:PLS > 5000p/s	Check parameter E10, E11, and E12	Pulse rate is 5000 pps or more with 0.1 ms selection.	
62:PLS > 1000p/s	Check parameter E10, E11, and E12	Pulse rate is 1000 pps or more with 0.5 ms selection.	
63:PLS > 500p/s	Check parameter E10, E11, and E12	Pulse rate is 500 pps or more with 1 ms selection.	
64:PLS > 25p/s	Check parameter E10, E11, and E12	Pulse rate is 25 pps or more with 20 ms selection.	
65:PLS > 15p/s	Check parameter E10, E11, and E12	Pulse rate is 15 pps or more with 33 ms selection.	
66:PLS > 10p/s	Check parameter E10, E11, and E12	Pulse rate is 10 pps or more with 50 ms selection.	
67:PLS > 5p/s	Check parameter E10, E11, and E12	Pulse rate is 5 pps or more with 100 ms selection.	
70:PLS<0.0001p/s	Check parameter E10, E11, and E12	Pulse rate is 0.00005 pps or less.	
71:Meas Mod Set	Check parameter C20	Measure Mode (C20) is set to Enhanced DF without selecting an optional code HF1 or HF2.	Check whether parameter C20 is correct.
72: Size Set Err	Check parameter C32	A value of 3000.1 mm or more is set for Nominal Size (C32).	Check whether parameter C32 is correct.
73: Adh Set Err	Check parameter K11 to K14	The condition in Adhesion detection level, Level:1<Level:2<Level:3<Level:4 is not satisfied.	Check whether parameters K11, K12, K13 and K14 are correct.

T0653.EPS

Setting Alarms (Device and measurements are normal but a warning is issued.)			
Display unit/BRAIN (□60) content	Alarm countermeasure message on display unit	Alarm description	Countermeasure
80:Adhesion Wng	–	Slight adhesion to electrodes.	Clean and check the electrodes. Refer to parameter K13.
82:Auto Zero Wng	–	Results of automatic zero adjustment are higher than the rated values.	Carry out adjustment as follows: • Check if the flowtube is filled with fluid. • Check if the flow velocity is completely zero. • Check the condition of grounding.
83:Fix Cur Wng	–	The current value is fixed.	Confirm whether the flow rate is in excess of the upper limit (108%) or below the lower limit (-8%), or whether upon entry to the Test Mode or not.
84:Disp Over Wng (only for display unit)	–	Overflow in the display digits during instantaneous flow rate display.	Check whether parameter C43 is correct.
90:Disp SW Wng (only for display unit)	–	Display unit switches are not operating.	Investigate whether the display unit cover is fitted or whether the cover's glass surface is dirty.

T0654.EPS

7. OPERATION VIA BRAIN TERMINAL (BT200)

7.1 BT200 Basic Operations

7.1.1 Key Layout and Display

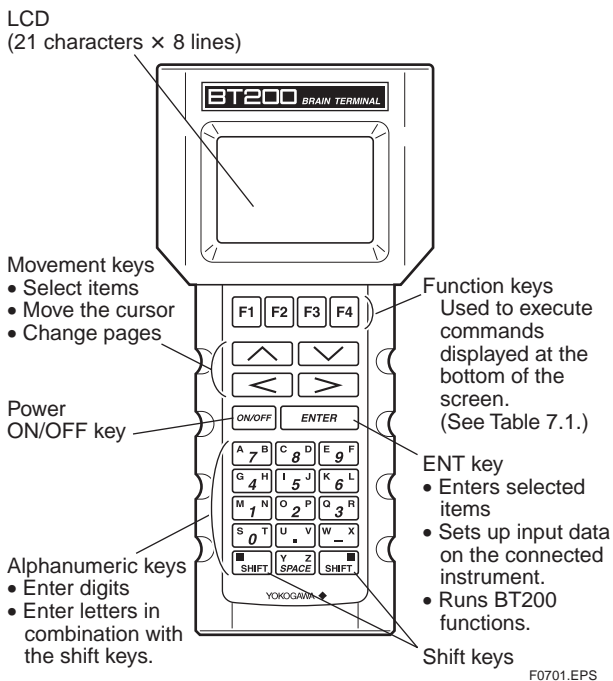
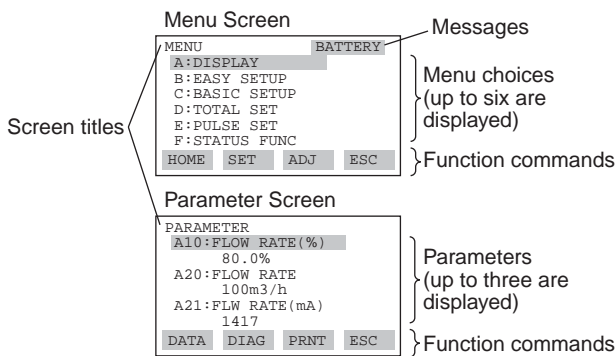

Figure 7.1 Key Layout

If **BATTERY** is displayed on the screen, it indicates that the battery voltage has dropped.



7.1.2 Key Descriptions

(1) Alphanumeric keys and shift keys

You can use the alphanumeric keys in conjunction with the shift keys to enter letters, digits, and symbols.

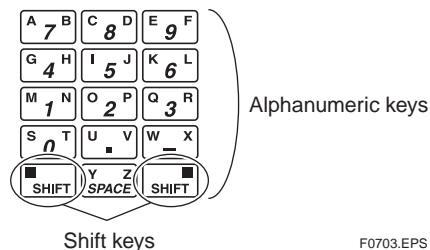

a) Entering digits, symbols, and spaces [i.e., 0-9, period (.), hyphen (-), underscore (_)]

Simply press the required alphanumeric key.

Entry	Key-in sequence
-4	[W - X] [G 4 H]
0.3	[S 0 T] [U . V] [Q 3 R]
1 _ -9	[M 1 N] [Y SPACE Z] [W - X] [E 9 F]

T0701.EPS

b) Entering letters (i.e., A through Z)

Press alphanumeric key following a shift key to enter the letter shown on the same side as the shift key. The shift key must be pressed for each letter being input.

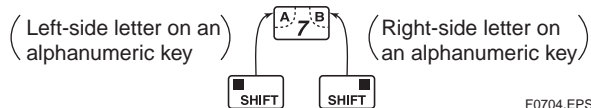

Entry	Key-in sequence
W	[SHIFT] [W - X]
IC	[SHIFT] [I 5 J] [SHIFT] [C 8 D]
J . B	[SHIFT] [I 5 J] [U . V] [SHIFT] [A 7 B]

T0702.EPS

Use the function key [F2] CAPS to select between uppercase and lowercase (for letters only). The case toggles between uppercase and lowercase each time you press [F2] CAPS.

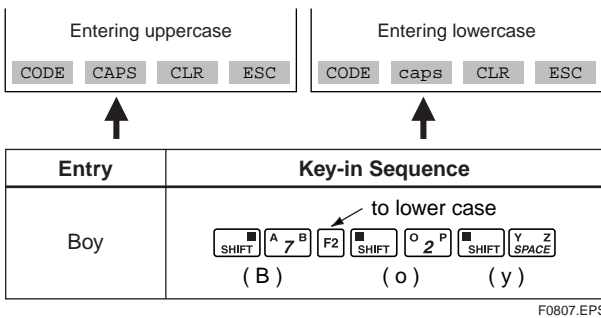

Use the function key [F1] CODE to enter symbols. The following symbols will appear in sequence, one at a time, at the cursor each time you press [F1] CODE:

/ . - , + *) (' & % \$ # " ' !

To enter characters next to these symbols, press [>] to move the cursor.

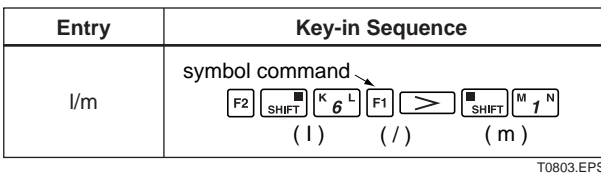

Function Command List

Command	Function
ADJ	Displays the ADJ menu
CAPS/caps	Selects uppercase or lowercase
CODE	Selects symbols
CLR	Erases input data or deletes all data
DATA	Updates parameter data
DEL	Deletes one character
DIAG	Calls the self-check panel
ESC	Returns to the most recent display
HOME	Displays the menu panel
NO	Quits setup and returns to the previous display
OK	Proceeds to the next panel
PARM	Enters the parameter number setup mode
SET	Displays the SET menu
SLOT	Returns to the slot selection panel
UTIL	Calls the utility panel
*COPY	Prints out parameters on display
*FEED	Paper feed
*LIST	Lists all parameters in the menu
*PON/POFF	Automatic printout mode on or off
*PRNT	Changes to the print mode
*GO	Starts printing
*STOP	Cancels printing

* Available on BT200-P00 (with printer).

T0804.EPS

(2) Function Keys

The functions of the function keys depend on the function commands on display.

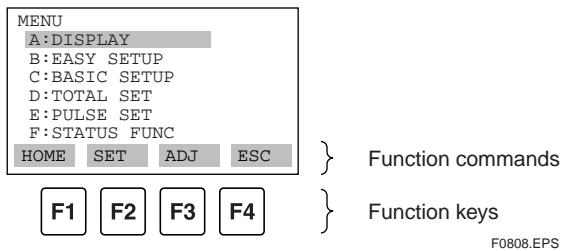

7.2 AXFA11 Operation Using a BT200

This section describes procedures for setting parameters using a BRAIN Terminal (BT200). For more details regarding AXFA11 functions, refer to Chapter 6: Parameter Description; and for more details regarding BT200 operation methods, refer to the BT200 User's Manual (IM IC0A11-01E).

7.2.1 BT200 Connection

Connection to a 4 to 20 mA DC signal line

The communication signal of the AXFA11 is superimposed onto the 4 to 20mA DC analog signals to be transmitted.

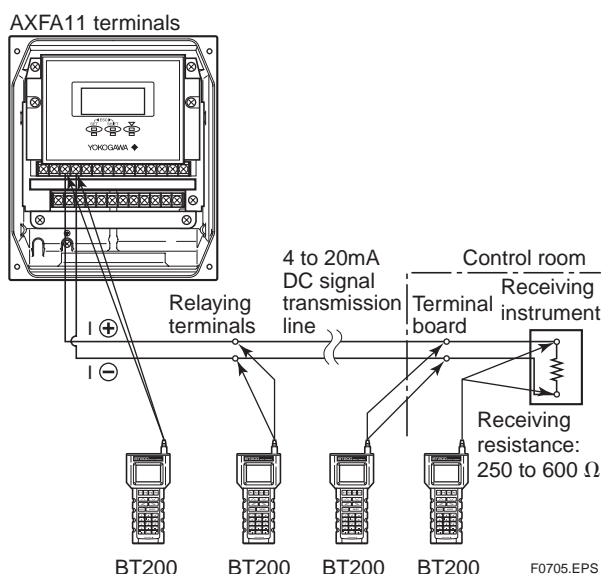

Figure 7.2 Connecting the BT200

IMPORTANT

Restrictions exist with regard to the distance over which communication is possible. (See Chapter 11: Outline.)

IMPORTANT

If the power of flowmeter is turned off within 30 seconds after parameters have been set, these settings will be canceled. Accordingly, please keep the power on for at least 30 seconds after setting parameters.

IMPORTANT

After approximately 5 minutes of inactivity, the Auto Power-Off function will operate to turn your BT200 off.

IMPORTANT

Be sure to set parameters as "Protect" on the write protect function after the finish of parameter setting. Refer to the "Menu P: Parameter Protection Items" and section "10.2.2" in detail.

NOTE

In case of BT200, the parameters are displayed in English only.

Even if the language with the exception of English is selected at **B10/H30: Language**, the parameters are displayed in English upon BT200.

7.2.2 The data update and upload/download function of BT200

(1) The data update of BT200

When the following parameters are displayed, the measured data is updated automatically every seven seconds.

Item	Name (BRAIN)	Item	Name (BRAIN)
A10	FLOW RATE (%)	G43	ALM RECORD2
A20	FLOW RATE	G44	ALM TIME 2
A21	FLW RATE (mA)	G45	ALM RECORD3
A30	TOTAL	G46	ALM TIME 3
A31	REV TOTAL	G47	ALM RECORD4
A32	DIF TOTAL	G48	ALM TIME 4
C44	VELOCITY CHK	N20	TEST SI1
G22	4-20 BURNOUT	N21	TEST SI2
G40	OPERATE TIME	P20	W PROTECT
G41	ALM RECORD1	P23	SOFT SEAL
G42	ALM TIME 1		

T0703.EPS

(2) Upload/download function of BT200

Upload function is used when the parameters of one AXFA11 are copied to the BT200. And download function is used when the parameters copied to the BT200 are set to another AXFA11.

For details, refer to BT200 User's Manual (IM IC0A11-01E). The targeted parameters for upload and download are following.

Item	Name (BRAIN)	Item	Name (BRAIN)
C11/B20	FLOW DAMPING	D10/B30	TOTAL UNIT
C31	SIZE UNIT	D11/B31	TOTAL SCALE
C32	NOMINAL SIZE	E10/B32	PULSE UNIT
C40/B21	FLOW UNIT	E11/B33	PULSE SCALE
C41/B22	TIME UNIT	H10/B40	DISP SELECT1
C42/B23	FLOW SPAN	H11/B41	DISP SELECT2
C43/B24	FLOW DECIMAL	H12/B42	DISP SELECT3

T0704.EPS

7.2.3 BT200 Screens & Flow Rate Data Display

Use the following procedure to display flow rate data on the BT200.

- The display of flow rate data is updated every 5 seconds.

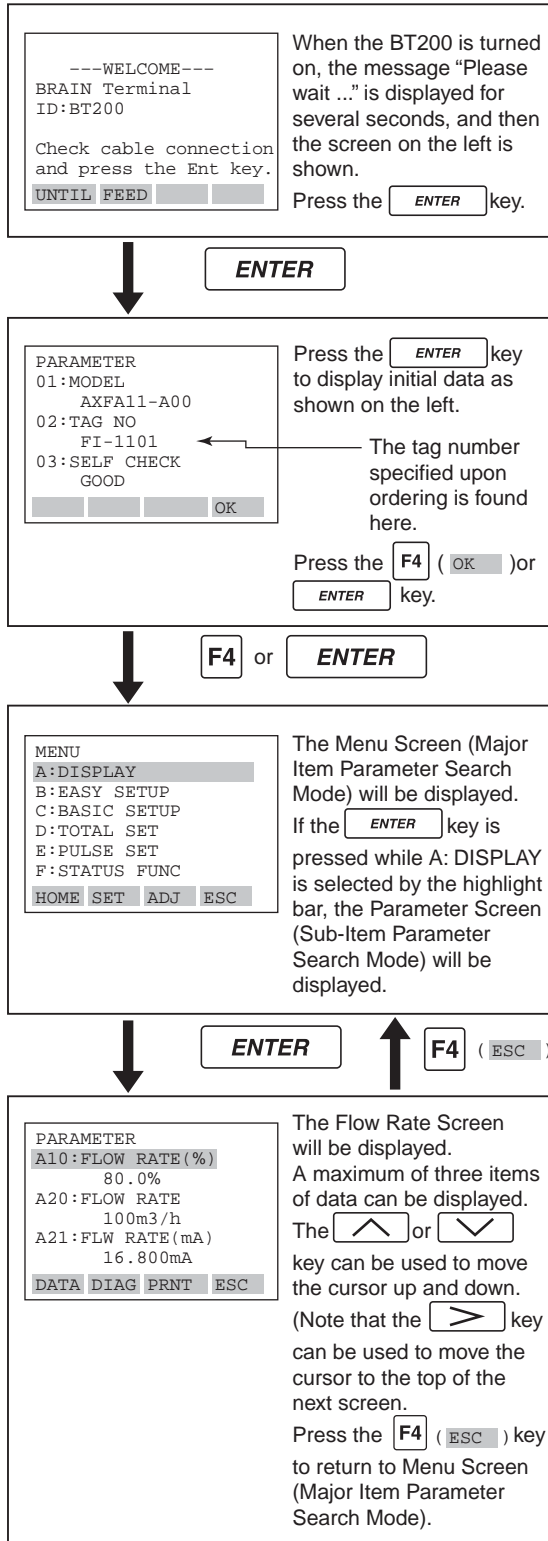

F0706.EPS

7.3 Parameter Setting Using a BT200

This section describes the procedure for setting of parameters using a BT200.

IMPORTANT

If the power of flowmeter is turned off within 30 seconds after parameters have been set, these settings will be canceled. Accordingly, please keep the power on for at least 30 seconds after setting parameters.

NOTE

Before updating any setting, remember to always check the data content you want to change as described in Chapter 6: Parameter Description.

7.3.1 BT200 Setting of Selection-Type Data: Flow rate units

In this example, the flow rate units specified by the selection-type parameter **B21: Flow Unit** are changed from m³ to l (Liter).

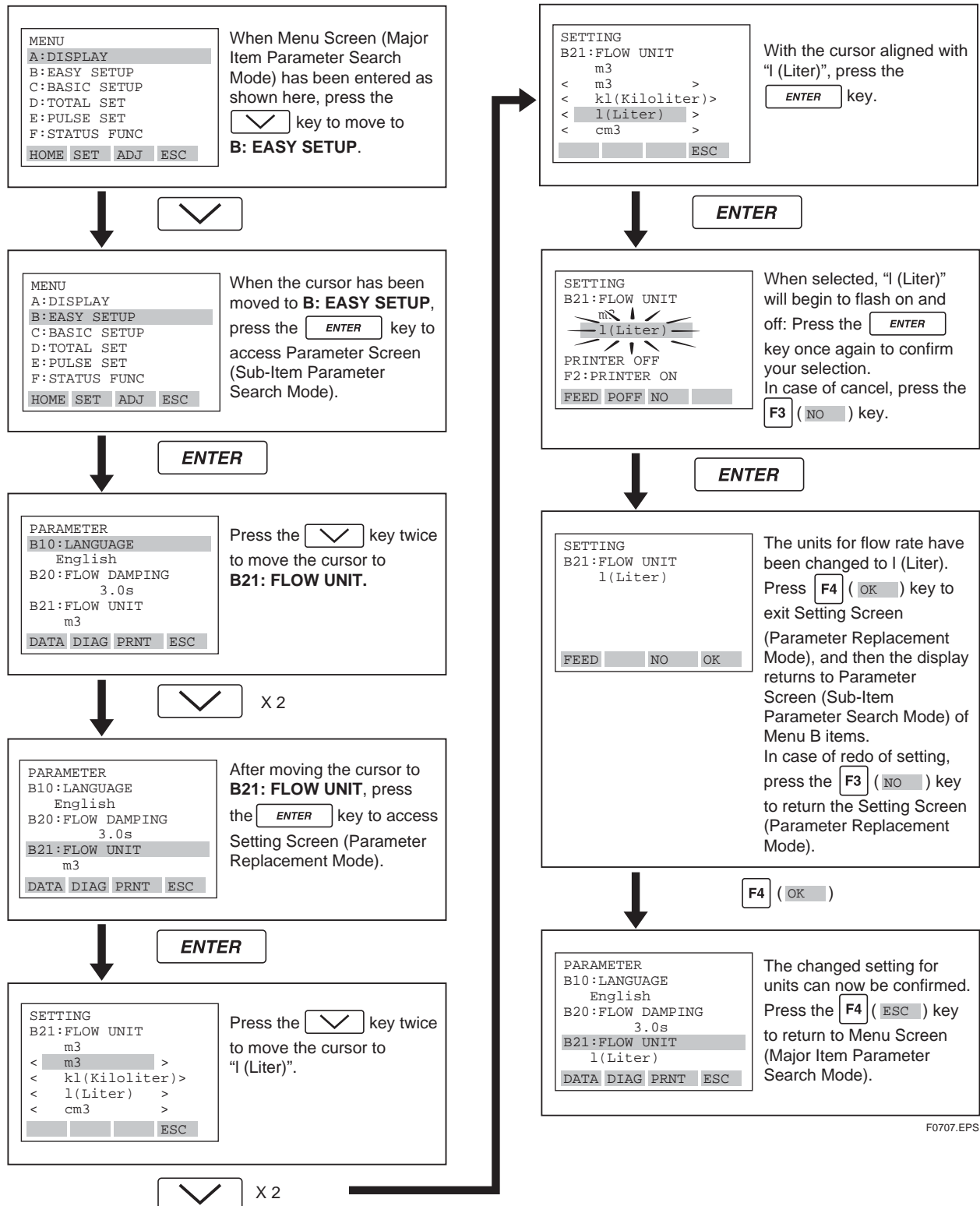

7.3.2 BT200 Setting of Numeric-Type Data: Flow rate span

In this example, the flow rate span specified by the numeric-type parameter **B23: Flow Span** is changed from 100.000 l/min. to 120.000 l/m.

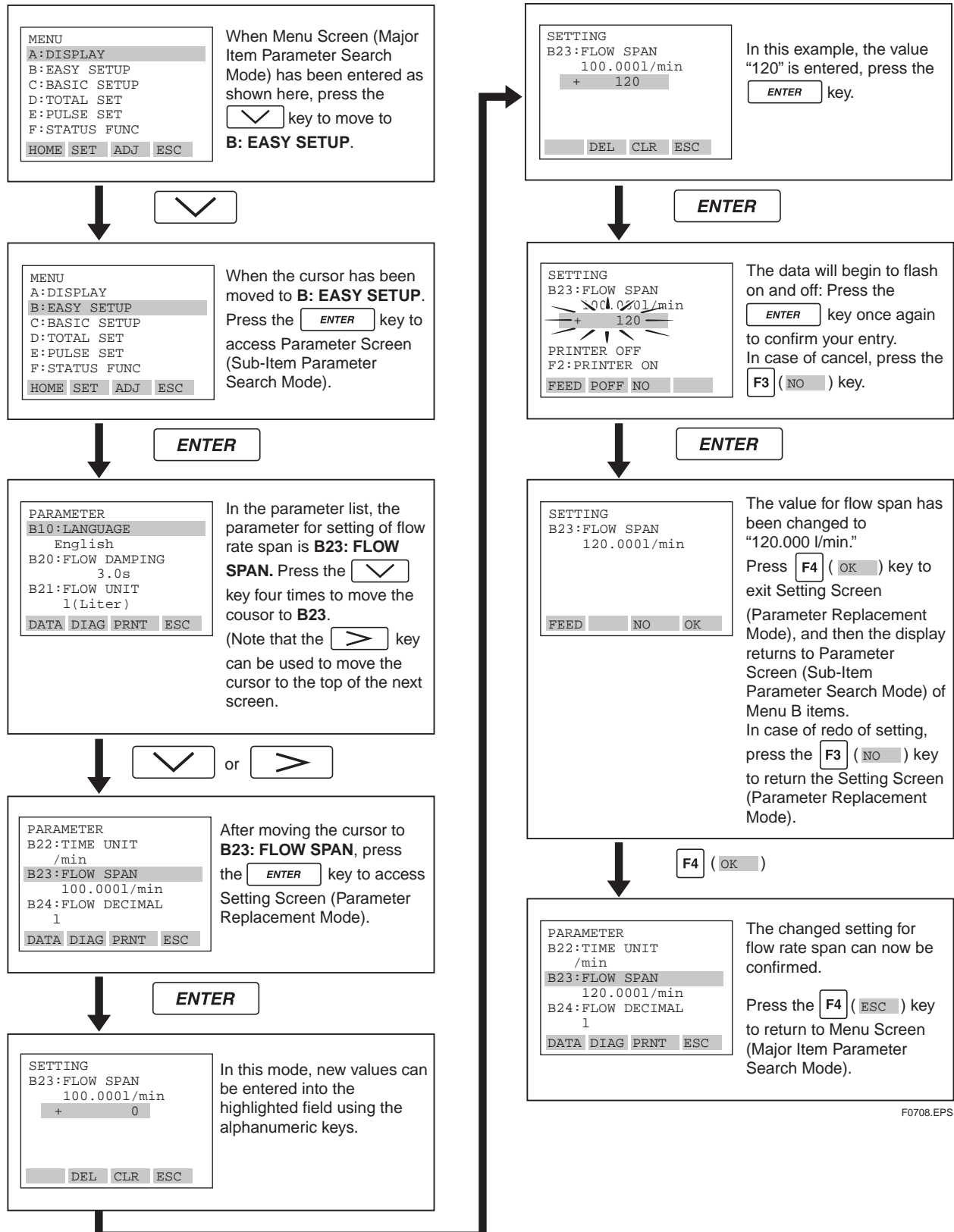

7.3.3 BT200 Setting of Alphanumeric-Type Data: Tag number

In this example, the tag number specified by the alphanumeric-type parameter **C10: TAG NO** is changed from “FI-1101” to “FI-1201”.

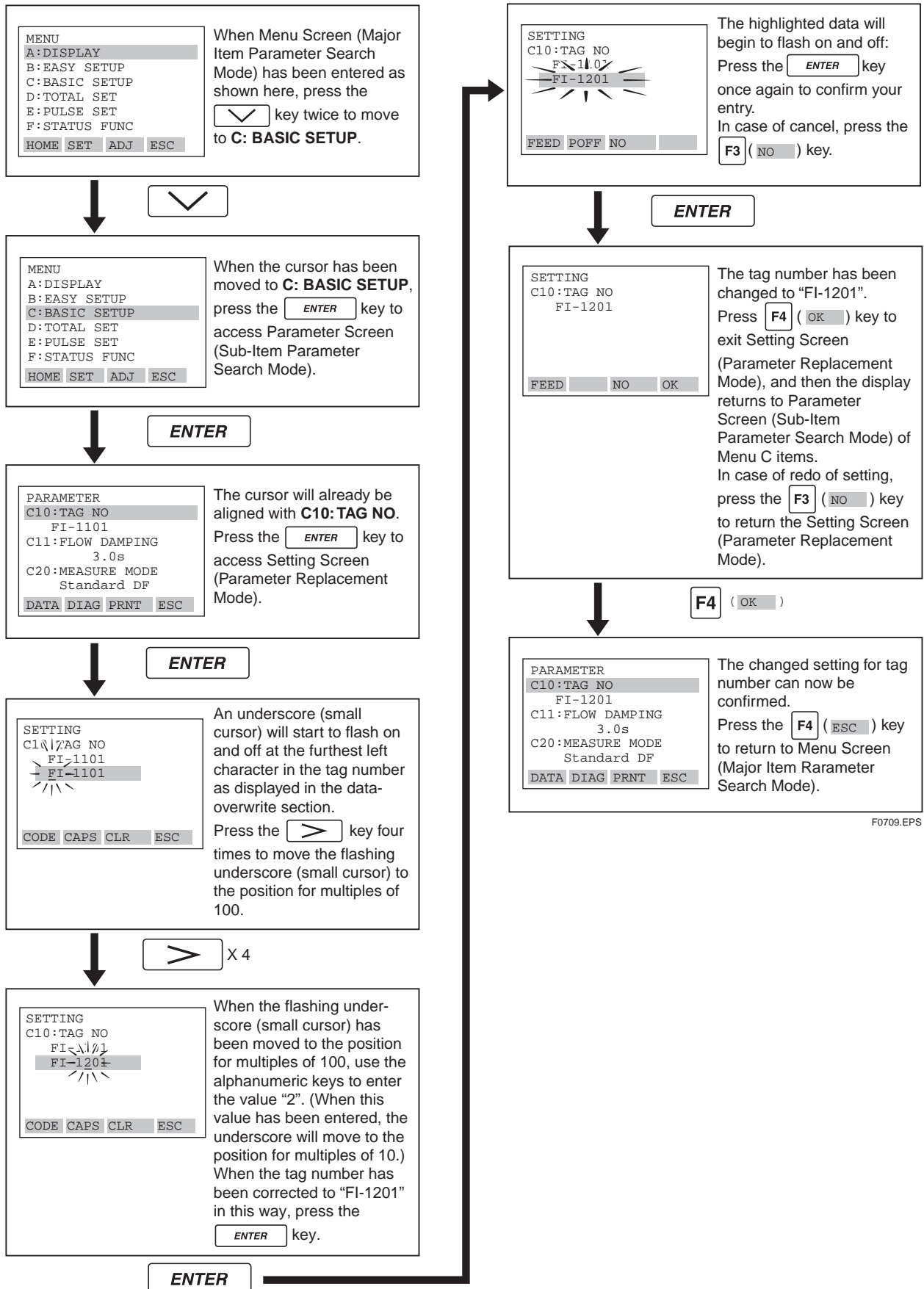

F0709.EPS

8. OPERATION VIA HART COMMUNICATOR

CAUTION

Matching of communicator DD and instrument DD

Before using the Model 275 HART Communicator, check that the DD (Device Description) installed in the communicator matches to that of the instruments to be set up. To check the DD in the instrument or the HART Communicator, follow the steps below. If the correct DD is not installed in the communicator, you must upgrade the DD at the official HART programming sites. For communication tools other than Model 275 HART Communicator, contact the respective vendors for upgrade information.

1. Checking the DD in the instrument

- 1) Connect the communicator to the instrument to be set up.
- 2) Open "Device Setup" and press [→].
- 3) Select "Review" and press [→].
- 4) Select "Review 4" and press [→].
- 5) By pressing [NEXT] or [PREV], locate "Fld dev rev" to show the DD of the instrument.

[Example]

```
AXFA11 :
Review 4
Fld dev rev
2
```

HELP PREV NEXT EXIT

"The instrument DD is Version 2"

2. Checking the DD in Model 275 HART Communicator.

- 1) Turn on only the communicator alone.
- 2) Select "Utility" from the main menu and press [→].
- 3) Select "Simulation" and press [→].
- 4) Select "YOKOGAWA" from the manufacturers list by pressing [↓] and then pressing [→] to enter selection.
- 5) Select the model name of the instrument (i.e. AXFA11) by pressing [↓] and then press [→] to show the DD of the communicator.

[Example]

```
HART Communicator
Fld dev rev
1 Dev v1, DD v2
2 Dev v2, DD v1
```

Versions 1 and 2

"The communicator DD supports Versions 1 and 2."

F0801.EPS

IMPORTANT

Be sure to set parameters as "Protect" on the write protect function after the finish of parameter setting. Refer to the "Menu P: Parameter Protection Items" and section "10.2.2" in detail.

NOTE

In case of HART Communicator, the parameters are displayed in English only. Even if the language with the exception of English is selected at "**Language**" setting display, the parameters are displayed in English upon HART Communicator.

8.1 Conditions of Communication Line

8.1.1 Interconnection between AXFA11 and HART Communicator

The HART Communicator can interface with the AXFA11 from the control room, the AXFA11 site, or any other wiring termination point in the loop, provided there is a minimum load resistance of 230 Ω between the connection and the receiving instrument. To communicate, it must be connected in parallel with the AXFA11, and the connections must be non-polarized. Figure 8.1.1 illustrates the wiring connections for a direct interface at the AXFA11 site. The HART Communicator can be used for remote access from any terminal strip as well.

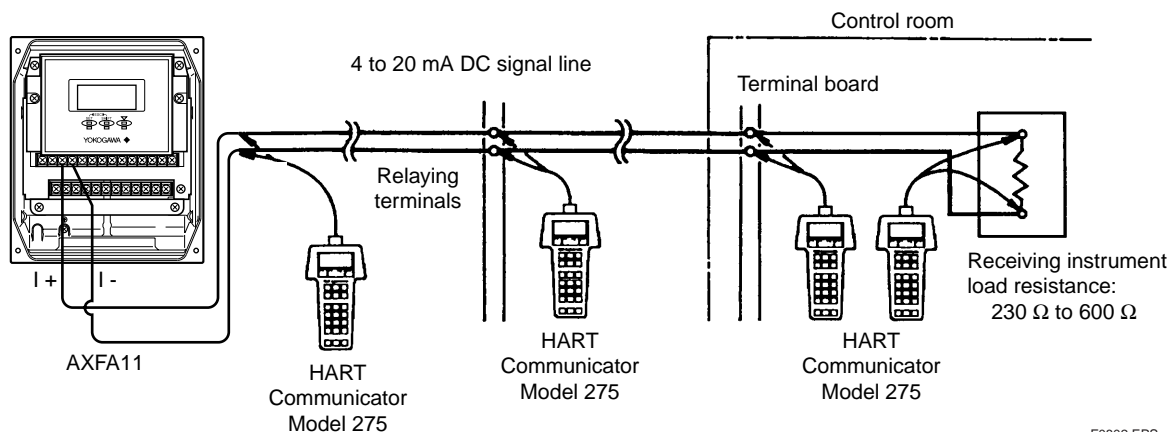

Figure 8.1.1 Interconnection Diagram

F0802.EPS

8.1.2 Communication Line Requirements

Specifications for Communication Line:

- Load resistance: 230 to 600 Ω (including cable resistance)
- Minimum cable size: 24 AWG, (0.51 mm diameter)
- Cable type: Single pair shielded or multiple pair with overall shield
- Maximum twisted-pair length: 6,500 ft (2,000 m)
- Maximum multiple twisted-pair length: 3,200 ft (1,000 m)

Use the following formula to determine cable length for a specific application:

$$L = \frac{65 \times 10^6}{(R \times C)} - \frac{(C_f + 10,000)}{C}$$

- where:
- L = length in feet or meters
 - R = resistance in ohms, current sense resistance
 - C = cable capacitance in pF/ft or pF/m
 - C_f = 50,000 pF

8.2 Basic Operation of the HART Communicator (Model 275)

8.2.1 Keys and Functions

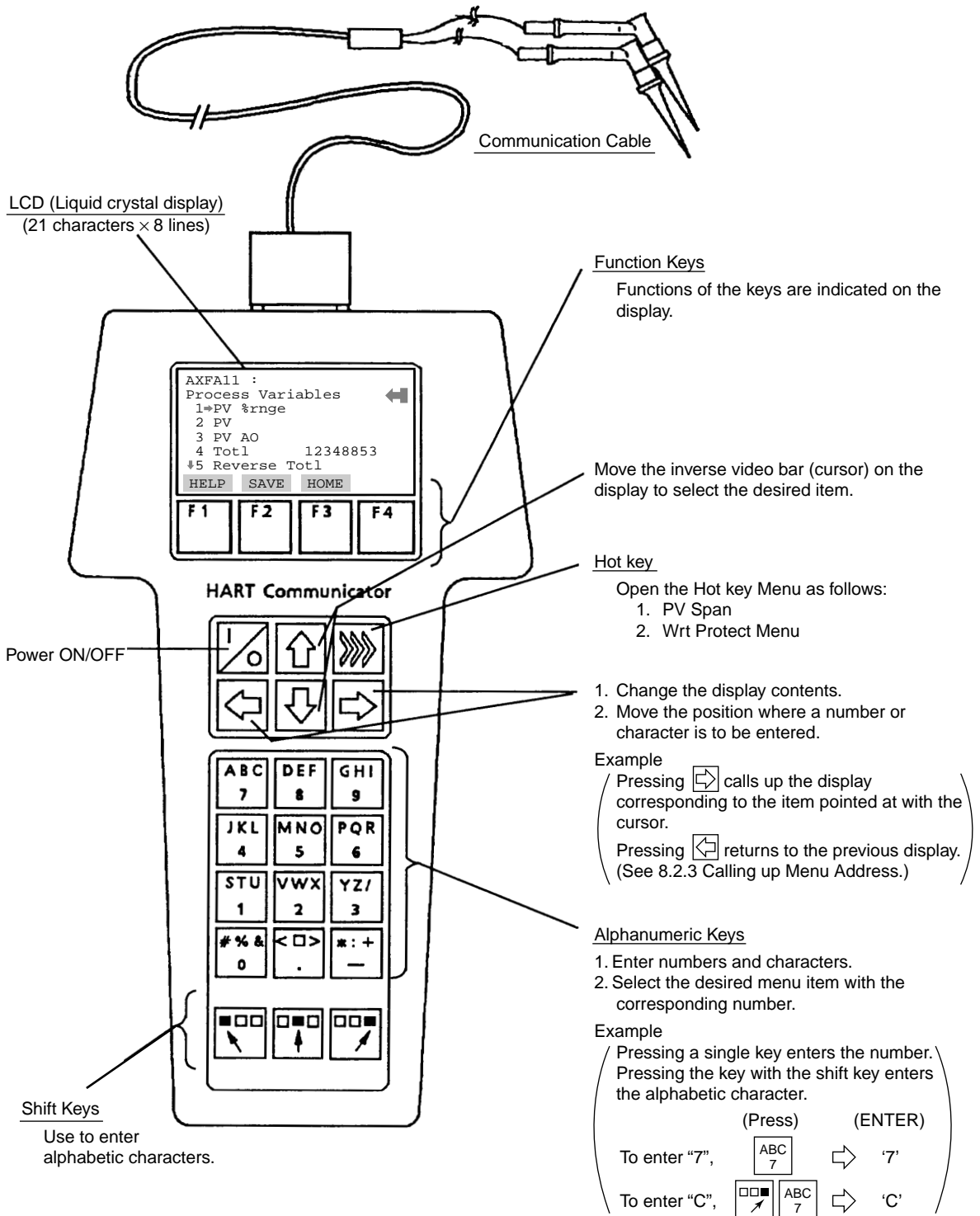

F0804.EPS

Figure 8.2.1 HART Communicator

8.2.2 Display

The HART Communicator automatically searches for the AXFA11 on the 4 to 20 mA loop when it is turned on. When the HART Communicator is connected to the AXFA11, it displays the “**Online**” menu as shown below.

(If AXFA11 is not found, the communicator displays the message “No Device Found. Press OK...” Press the OK ‘F4’ function key and the main menu appears. Please retry after confirming the connection with the AXFA11.)

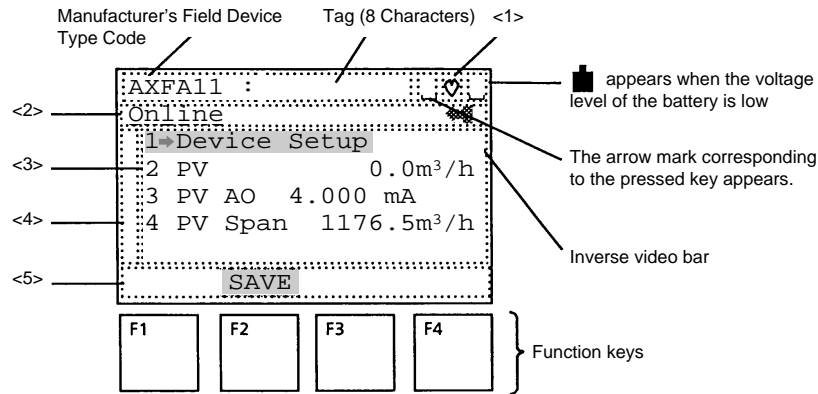

F0805.EPS

Figure 8.2.2 Display

- <1> ♥ appears and flashes during communication between the HART Communicator and the AXFA11. In Burst Mode*, ♥ appears.
- <2> The current display menu title appears.
- <3> Each item in menu <2> appears.
- <4> ↓ and/or ↑ appear when the items are scrolled out of the display.
- <5> On any given menu, the label appearing above a function key indicates the function of that key for the current menu.

* Refer to “8.3.4.7 Burst Mode”.





8.2.3 Calling Up Menu Addresses

The 8.3.5 Menu Tree shows the configuration of the “**Online**” menu which is needed for operation with the HART Communicator. The desired item can be displayed with ease by understanding the menu configuration.

When the HART Communicator is connected to the AXFA11, the “**Online**” menu will be displayed after the power is turned on (see figure 8.2.2). Open the desired item as follows:

Key Operation

There are two ways of selecting the desired menu item.

1. Use the  or  key to select the desired item, and then press the  key.
 2. Press the number key displayed for the desired item.
- To return to the previous display, press the  key, **EXIT (F4)**, **ESC (F3)** or **ABORT (F3)**.



NOTE

Setting parameters on the display unit of the AXFA11 is not possible during HART Communication.

8.2.4 Entering, Setting and Sending Data

The data which are input with the keys are set in the HART Communicator by pressing **ENTER (F4)**. Then, by pressing **SEND (F2)**, the data are sent to the AXFA11. Note that the data are not set in the AXFA11 if **SEND (F2)** is not pressed. All the data set with the HART Communicator is held in, memory unless power is turned off, so every data can be sent to the AXFA11 at one lot.

8.3 Parameters

8.3.1 Parameter Configuration

The parameters of the HART Communicator are constructed hierarchically. The menu tree for the “**Online**” menu is shown in the 8.3.3 Menu Tree.

See “Chapter 6. Parameter Description” about the function of each parameter. Note the differences between the parameters on the AXFA11 display and those on HART Communicator.

The “**Online**” menu summary is shown below.

Table 8.1.3 Online Menu Summary

No.	Display Item	Contents
1	Device Setup	Set parameters for AXFA11.
2	PV	Display process value in engineering unit.
3	PV AO	Display analog output in mA.
4	PV Span	Display set span in engineering unit.

T0801.EPS

8.3.2 Data Renewing

There are two methods to load the AXFA11 data from/to the HART Communicator – periodic data renewing and discretionary data renewing.

(1) Periodic Data Renewing

The following data are renewed in 0.5 to 2 second cycles.

PV, PV AO, PV % rnge, Totl, Reverse Totl, Dif Totl, Power Frequency, Velocity Check, Operation Time, Alm Record1, Alm Record Time1, Alm Record2, Alm Record Time2, Alm Record3, Alm Record Time3, Alm Record4, Alm Record Time4, Test SI1, Test SI2, Write protect

(2) Discretionary Data Renewing

The following data can be loaded from/to the AXFA11. Upload can be done with **SAVE (F2)** on any the “**Online**” menu selection, and download can be done on the **Saved Configuration** menu in the “**Offline**” menu. (Refer to HART Communicator Manual.)

PV Damping, Nominal Size Unit, Nominal Size, Base Flow Unit, Base Time Unit, PV Span, Flow Decimal Pnt, Density Unit, Mass Flow Density, User Span Select, Flow User Unit, Flow User Span, Total Unit, Total Scale, Total Decimal Pnt, Total Low Cut, Total Execution, Ttl Set Val Lower, Ttl Set Val Upper, Ttl Switch Lower, Ttl Switch Upper, Ttl User Select, Ttl User Unit, Pulse Unit, Pulse Scale, Pulse Width, Pulse Low Cut, Pulse Active Mode, SO1 Function, SO2 Function, SI1 Function, SI2 Function, SO1/2 Active Mode, SI1/2 Active Mode, Forward Span2, Forward Span3, Forward Span4, Reverse Span1, Reverse Span2, Reverse Span3, Reverse Span4, Auto Range Hys, Bi Direction Hys, Low Alarm, High Alarm, Low Low Alarm, High High Alarm, H/L Alarm Hys, Alm Out Act Mode, 4-20mA Alarm Out, Alm-Setting, Alm-Sig Over, Alm-Emp Pipe, Alm-HH/LL, Alm-Adhesion, Display Select1, Display Select2, Display Select3, Display Cycle, Language, 4-20mA Low Cut, 4-20mA Low Lmt, 4-20mA High Lmt, Flow Direction

**NOTE**

Data changed with the HART Communicator is sent to the AXFA11 by pressing **SEND (F2)** of the HART Communicator.

8.3.3 Checking for Problems

The self-diagnostic function of the AXFA11 is explained in Section 6.5 “Alarm Functions” By using the HART Communicator, it is also possible to carry out this function in the “Test/Status” parameter. Test for each error.

* Open the “Test/Status” setting display.

1. Device Setup → 2. Diag/Service → **3. Test/Status**

8.3.4 Setting Parameters

As mentioned in Section 5.2.2 “Setting Mode,” the AXFA11’s parameters are divided into three types:

- i. Selection type
- ii. Numeric type
- iii. Alphanumeric type

This section describes how to set these parameters using a HART communicator.

**NOTE**

All three parameters must be set to obtain a correct signal.
Nominal size, flow rate span and meter factor must be set.

8.3.4.1 Example of Setting Selection-Type Data: Base Flow Unit

This example describes the setting of the flow rate units for the selection-type parameter “Base Flow Unit” from m³ to l (Liter).

Open the “Base Flow Unit” setting display.

1. Device Setup → 3. Easy Setup → **3. Base Flow Unit**

```

1 AXFA11 : FI-1100
  Base Flow Unit
  m3
  m3
  K1(Kiloliter)
  l(Liter)
  cm3
  ESC ENTER
  
```



×2

Select “**1(Liter)**”.

```

2 AXFA11 : FI-1100
  Easy Setup
  1 Language
  2 PV Damping
  3-Base Flow Unit 1
  4 Base Time Unit /h
  5 PV Span
  SEND HOME
  
```



(ENTER)

Press **ENTER (F4)**.

```

3 AXFA11 : FI-1100
  Easy Setup
  1 Language
  2 PV Damp
  3-Base Flow Unit 1
  4 Base Time Unit /h
  5 PV Span
  SAVE HOME
  
```



(SEND)

Press **SEND (F2)** to set the data into the AXFA11.

8.3.4.2 Example of Setting Numeric-Type Data: PV Span

This example describes the setting of the flow rate span for the numeric-type parameter “PV Span” from 100 l/min to 120 l/min.

There are two ways to open the “PV Span” setting display. Following the menu tree configuration, “PV Span” is opened as follows:

To open “PV Span” using the “Hot key”, proceed as follows:



F0808.EPS



NOTE

The “Hot key” can be used to set the easy call up parameters, “PV Span” (Flow Span) and “Wrt Protect Menu” (Write protect function).

Open the “PV Span” setting display.

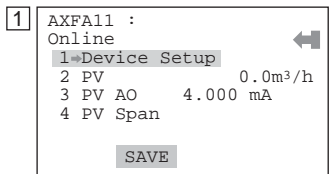

Press **Hot key**.

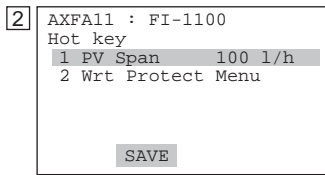

Select “**PV Span**”.

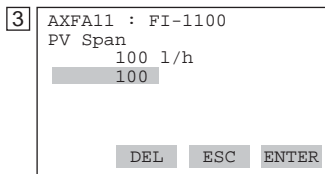

‘120’

Enter “120” with alphanumeric keys.

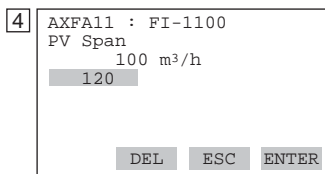

(ENTER)

Press **ENTER (F4)**.

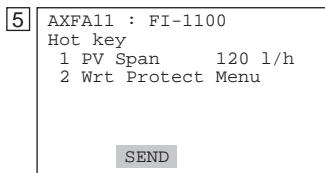

(SEND)

Press **SEND (F2)** to set the data into the AXFA11.

Return to the previous display by pressing  or .

F0809.EPS

8.3.4.3 Example of Setting Alphanumeric-Type Data: Tag Number

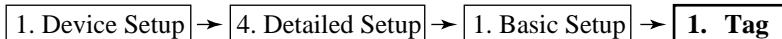

This example describes the setting of the tag number for the alphanumeric-type parameter ‘Tag’ from “FI-1101” to “FI-1201”.

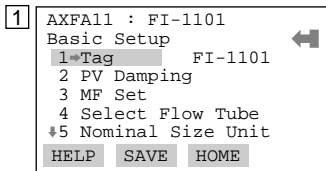

Display

Operation



 or  Select “Tag”.

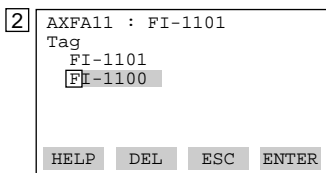

The display for the Tag setting appears.
(The default value of “Tag” is blank.)

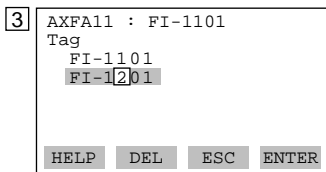

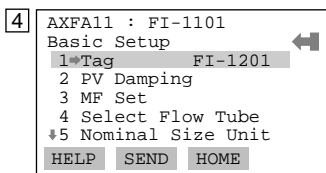

 ×4 Move the cursor to “1”.
Then press “2” to change the Tag No. “FI-1101” to “FI-1201”.

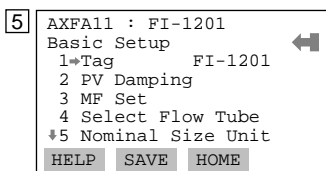

 Press **ENTER (F4)** .
(ENTER)



 Press **SEND (F2)** to set the data into the AXFA11.
 Press **HOME (F3)**, and return to the “Online” menu.

F0810.EPS

 **NOTE**

In case of HART protocol, up to 8 characters can be set with “Tag”.



8.3.4.4 Example 1 of Other Settings: Meter Factor

The “**Meter Factor**” is engraved on the data plate of the combined flowtube.

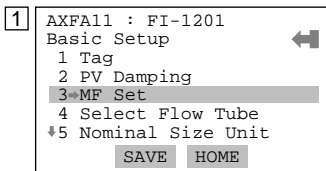
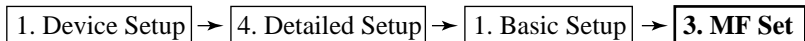

The meter factor is required to compute the correct electromotive force proportional to the fluid velocity, and is determined by actual flow-test calibration at the factory.

Open the “**MF**” setting display:

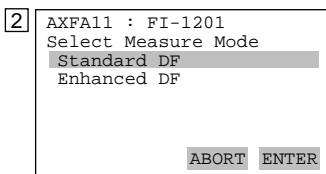

 or  Select “**MF Set**”.



 or  Select “**Standard DF**”.
 (ENTER)

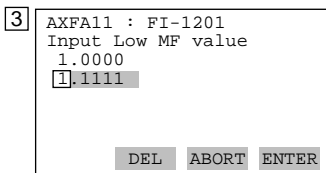

 Enter “1.1111” with alphanumeric keys.
 Press **ENTER (F4)**.
 (ENTER)

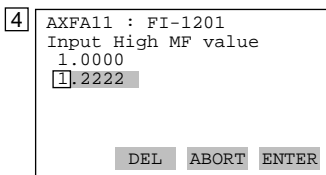

 Enter “1.2222” with alphanumeric keys.
 Press **ENTER (F4)**.
 (ENTER)

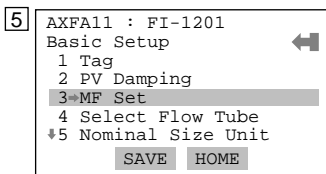

 Press **HOME (F3)**, and return to the “**Online**” menu.
 (HOME)

8.3.4.5 Example 2 of Other Settings: Power Frequency (For DC version only)

 **IMPORTANT**

In situation where a DC power supply is used for converters, set the local commercial power frequency in area where the converter is installed. The flowmeter is set to 50.00 Hz at the factory.
Set “No” for “Power Synch” and the local commercial power frequency for “Power Frequency”.

Open the “Power freq” setting display:



( x9)

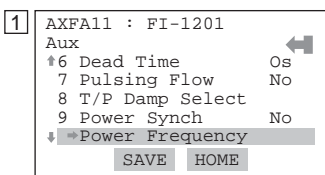

Select “Power Frequency”.

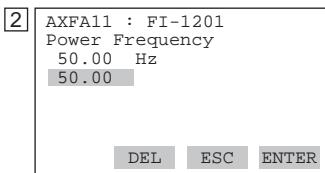

‘60.0’

Enter “60.00” with alphanumeric keys.

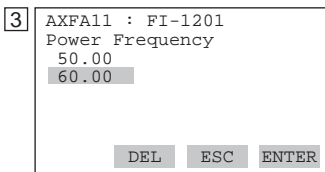

Press **ENTER (F4)**.

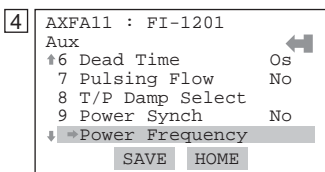

Press **SEND (F2)** to set the data into the AXFA11.



Press **HOME (F3)**, and return to the “Online” menu.

8.3.4.6 Example 3 of Other Settings: Trim Analog Output

Fine output adjustment is carried out with “D/A trim” or “Scaled D/A trim”.

- **D/A trim**

“D/A trim” is to be carried out if the calibration digital ammeter does not read exactly 4.000 mA and 20.000 mA with output signals of 0% and 100%.

- **Scaled D/A trim**

“Scaled D/A trim” is to be carried out if the output is adjusted using a voltmeter or other types of meters with a 0% to 100% scale.

**IMPORTANT**

When “D/A trim” or “Scaled D/A trim” is carried out, the warning message “**83: Fix Cur Wng**” is displayed on the display unit.

Example 1: For adjustments using an ammeter (capable of measuring $\pm 1\mu\text{A}$.)

F0814-1.EPS

Open the “Output trim” display:

1. Device Setup → 2. Diag/Service → 2. Adjustment → 3. D/A trim

1 AXFA11 : FI-1201
Adjustment
1 Auto Zero Exe
2 Magflow Zero
3 D/A trim
4 Scaled D/A trim
SAVE HOME



Select “D/A trim”.

2 AXFA11 : FI-1201
WARN-Loop should be
removed from
automatic control
ABORT OK



Press **OK (F4)**.

(OK)

3 AXFA11 : FI-1201
Connect reference
meter
ABORT OK



Connect an ammeter (capable of measuring $\pm 1\mu\text{A}$), and press **OK (F4)**.

(OK)

4 AXFA11 : FI-1201
Setting fld dev
output to 4mA
ABORT OK



Press **OK (F4)**, and the AXFA11 outputs an output signal of 0%.

(OK)

5 AXFA11 : FI-1201
Enter meter value
4.0000
HELP DEL ABORT ENTER

‘4.115’



Ammeter reading: 4.115

Enter the ammeter’s reading of **4.115**, and press **ENTER (F4)**.
(The output of the AXFA11 changes.)

(ENTER)

F0814-2.EPS

8. OPERATION VIA HART COMMUNICATOR

6 AXFA11 : FI-1201
 Fld dev output 4.000
 mA equal to reference
 meter?
 1 Yes
 2 No

ABORT ENTER

F4
 (ENTER)

Ammeter reading: 4.000

Because the reading on the ammeter is 4.000 mA, select “Yes” and press **ENTER (F4)**.

If the reading is not 4.000 mA, select “No”.

Repeat step 5 until the ammeter reads 4.000 mA.

7 AXFA11 : FI-1201
 Setting fld dev
 output to 20mA

ABORT OK

F4
 (OK)

Press **OK (F4)**, and the AXFA11 outputs an output signal of 100%.

8 AXFA11 : FI-1201
 Enter meter value
 20.000

HELP DEL ABORT ENTER

'19.050'
 F4
 (ENTER)

Ammeter reading: 19.050

Carry out the same procedures as those described in 5.

9 AXFA11 : FI-1201
 Fld dev output 20.000
 mA equal to reference
 meter?
 1 Yes
 2 No

ABORT ENTER

F4
 (ENTER)

Ammeter reading: 20.000

“Returning fld dev to original output” appears.

10 AXFA11 : FI-1201
 NOTE-Loop may be
 returned to automatic
 control

OK

F4
 (OK)

Press **OK (F4)**.

11 AXFA11 : FI-1201
 Adjustment ←
 1 Auto Zero Exe
 2 Magflow Zero
 3 D/A trim
 4 Scaled D/A trim

HELP SAVE HOME

F3
 (HOME)

Press **HOME (F3)**, and return to the “Online” menu.

Example 2: For adjustments using a voltmeter

F0816-1.EPS

1 AXFA11 : FI-1201
Adjustment
1 Auto Zero Exe
2 Magflow Zero
3 D/A trim
4 Scaled D/A trim
HELP SAVE HOME

JKL
4

Select the “Scaled D/A trim”.

2 AXFA11 : FI-1201
WARN-Loop should be
removed from
automatic control
ABORT OK

F4
(OK)

Press **OK (F4)**.

3 AXFA11 : FI-1201
Trim will be scaled
from 4.000 to 20.000
1 Proceed
2 Change
ABORT ENTER

VWX
2

Select “Change”.
The same operations as for “D/A trim” are required when selecting “Proceed”.

4 AXFA11 : FI-1201
Set scale- Lo output
value
4.000000
4.000000
DEL ABORT ENTER

'1'
F4
(ENTER)

Enter the reading value on the meter when the signal is 4 mA.
In this case, enter the value of the voltage across a 250 Ω resistor (1 V), and press **ENTER (F4)**.

5 AXFA11 : FI-1201
Set scale- Hi output
value
20.000000
20.000000
DEL ABORT ENTER

'5'
F4
(ENTER)

Enter the reading value on the meter when the signal is 20 mA.
Then, enter “5” (5 V), and press **ENTER (F4)**.

6 AXFA11 : FI-1201
Trim will be scaled
from 1.000 to 5.000
1 Proceed
2 Change
ABORT ENTER

STU or F4
1 (ENTER)

Select “Proceed” and press **ENTER (F4)**.

7 AXFA11 : FI-1201
Connect reference
meter
ABORT OK

F4
(OK)

Connect the voltmeter, and press **OK (F4)**.

8 AXFA11 : FI-1201
Setting fld dev
output to 4mA
ABORT OK

F4
(OK)

Press **OK (F4)**. The output signal of 0% is output.

F0816-2.EPS

```

9 AXFA11 : FI-1201
  Enter meter value
  1.000000
  1.000000
  DEL ABORT ENTER
  
```

'1.01'
 F4
 (ENTER)

Voltmeter reading: 1.010

Enter the voltmeter's reading of 1.010, and press **ENTER (F4)**.
 (The output of the AXFA11 changes.)

```

10 AXFA11 : FI-1201
   Scaled output: 1.000
   equal readout
   device?
   1 Yes
   2 No
   ABORT ENTER
  
```

F4
 (ENTER)

Voltmeter reading: 1.000

Because the reading on the voltmeter is 1.000, select "**Yes**" and press **ENTER (F4)**.
 If the reading is not 1.000, select "**No**".
 Repeat step 9 until the voltmeter reads 1.000 V.

```

11 AXFA11 : FI-1201
   Settting fld dev
   output to 20mA
   ABORT OK
  
```

F4
 (OK)

Press **OK (F4)**. The output signal of 100% is output.

```

12 AXFA11 : FI-1201
   Enter meter value
   5.000000
   5.000000
   DEL ABORT ENTER
  
```

'5.21'
 F4
 (ENTER)

Voltmeter reading: 5.210

Enter the voltmeter's reading of 5.210, and press **ENTER (F4)**.

```

13 AXFA11 : FI-1201
   Scaled output: 5.210
   equal readout
   device?
   1 Yes
   2 No
   ABORT ENTER
  
```

F4
 (ENTER)

Voltmeter reading: 5.000

Select "**Yes**" and press **ENTER (F4)**.
 "**Returning fld dev to original output**" appears.

```

14 AXFA11 : FI-1201
   NOTE-Loop may be
   returned to automatic
   control
   OK
  
```

F4
 (OK)

Press **OK (F4)**.

```

15 AXFA11 : FI-1201
   Adjustment
   1 Auto Zero Exe
   2 Magflow Zero
   3 D/A Trim
   4=Scaled D/A trim
   HELP SAVE HOME
  
```

F3
 (HOME)

Press **HOME (F3)**, and return to the "**Online**" menu.

F0816-3.EPS



IMPORTANT

D/A trim should be executed only at single range mode. If D/A trim is executed at Bi direction mode, it is possible that the current output becomes 108%.

8.3.4.7 Example 4 of Other Settings: Burst Mode

The AXFA11 continuously sends its stored data when the “**Burst mode**” is set to “On”. Any one of instantaneous flow rate, output in %, totalization values or current output can be selected and sent. The data is sent intermittently as a digital signal when the AXFA11 is set in the “**Burst mode**”.

Setting of Burst Mode

Open the “**Burst option**” display:

1. Device Setup → 4. Detailed Setup → 5. HART Output → **4. Burst option**

```
AXFA11 : FI-1100
Burst option
*****
PV
% range/current
Process vars/crnt
HELP      ESC  ENTER
```

F4
(ENTER)
F2
(SEND)

Select the type of data to be sent.

- Instantaneous flow rate (PV)
 - Output in % and current output (% range/current)
 - Instantaneous flow rate, totalization value* and current output (Process vars/crnt)
- * “Totl”, “Reverse Totl” or “Dif Totl”

Call up “**Burst mode**” display.

5. HART Output → **3. Burst mode**

1

```
AXFA11 : FI-1100
Burst mode
Off
On
ESC  ENTER
```

↓
F4
(ENTER)

Select “**On**” and press **ENTER (F4)**.

2

```
AXFA11 : FI-1100
HART Output
1 Poll addr      0
2 Num req preams 5
3 Burst mode     On
4 Burst option   PV
HELP  SEND  HOME
```

F2
(SEND)

Press **SEND (F2)**.

F0817.EPS

Exiting Burst Mode

Open the “**Burst mode**” display, and select “**Off**”.

8.3.4.8 Example 5 of Other Settings: Multidrop Mode

Field devices in “**Multidrop Mode**” refers to the connection of several field devices on a single communication line. Up to 15 field devices can be connected when set to the multidrop mode. To activate multidrop communication, the field device address must be changed to a number from 1 to 15. This change deactivates the 4 to 20 mA output and changes it to 4 mA.

Setting of Multidrop Mode

Open the “**Poll addr**” display:

1. Device Setup → 4. Detailed Setup → 5. HART Output → **1. Poll addr**

```
AXFA11 : FI-1100
Poll addr
0
0
HELP  DEL  ESC  ENTER
```

'1'
F4
(ENTER)
F2
(SEND)

Set the polling address (a number from 1 to 15) and press **ENTER (F4)**.

Then, press **SEND (F2)** to send the data.

F0818.EPS

Open the “Auto Poll” display:

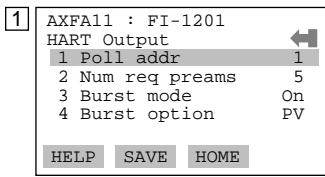
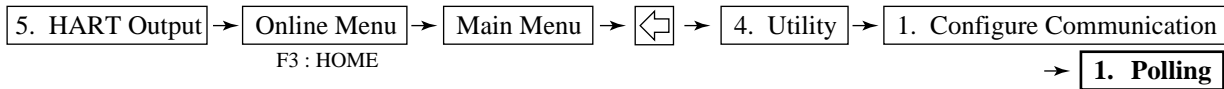

Return to the “Online” menu with **HOME (F3)**.

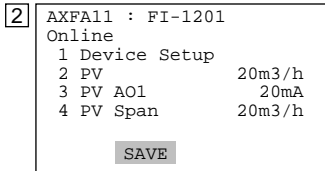

Return to the “Main” menu with a “previous” key.

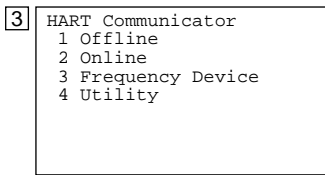

Select “Utility”.

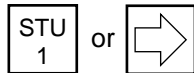
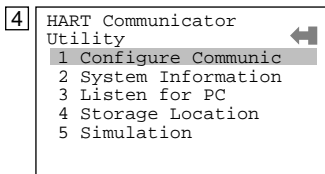

Select “Configure Communication”.

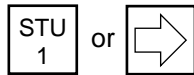
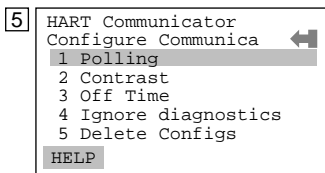

Select “Polling”.

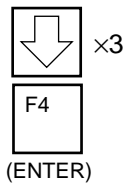
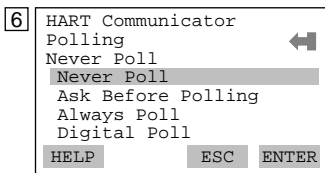

Select “Digital Poll” and press **ENTER (F4)**.

F0819.EPS

NOTE

1. If “Never Poll” is selected in “Polling” when the address is assigned, the “Online Menu” cannot be called up and displayed. Be sure to select “Digital Poll” in “Polling” after assigned the polling address.
2. When the same polling address is assigned for two or more field devices in multidrop mode, communication with these field devices is disabled.

Example: Communication when set in the multidrop mode.

F0820-1.EPS

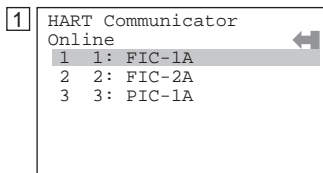

The HART Communicator searches for field devices that are set in the multidrop mode when the HART Communicator is turned on.

When the HART Communicator is connected to one of these field devices, tag will be displayed.

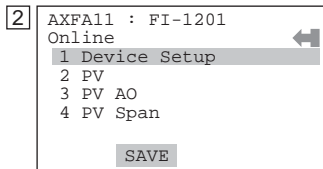

Select the desired field device. After that, normal communication with the selected field device is possible. The communication speed, however, is slow in this case.

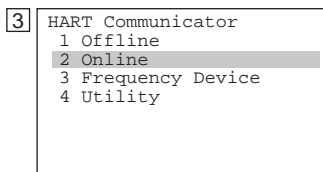

To communicate with another field device, open display 3, and select “Online”.

Display 1 will appear. Repeat the above operation.

F0820-2.EPS

Exiting Multidrop Mode

First, open the “Poll addr” display, and assign the address to 0.

Then, open the “Polling” display, and select “Never Poll”.



NOTE

If the above exiting method is carried out in the reverse order, the “Online” menu cannot be called up.

8.3.4.9 Example 6 of Other Settings: Write Protection

The “Write Protection” function is used to inhibit parameter changes to the AXFA11. For a more detailed description, refer to Chapter 6. Parameter Description, and Chapter 9. Maintenance.



NOTE

When the write protection function is activated, data setting changes in all parameters of the AXFA11 are inhibited and cannot be changed using either the HART Communicator or the AXFA11 front panel key switches.

Setting Password

Example: Set the password to "1 2 3 4"

F0821-1.EPS

Open "Wrt Protect Menu" in the Hot key Menu.



1 AXFA11 : FI-1201
Hot key
1 PV Span 1 m/s
2-Wrt Protect Menu

SAVE

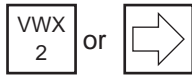

Select "Wrt Protect Menu".

2 AXFA11 : FI-1201
Wrt Protect Menu
1 Write protect No
2 Enable Wrt 10min
3 New Password
4 Software Seal Keep

HELP SAVE



Select "New Password".

3 AXFA11 : FI-1201
Enter new password to
change state of write
protect

DEL ABORT ENTER

Enter "1 2 3 4" and press ENTER (F4).

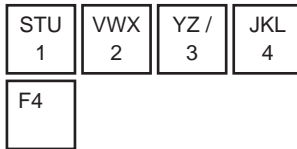

(ENTER)

4 AXFA11 : FI-1201
Re-enter new password
within 30 seconds:
1234
1234

DEL ABORT ENTER

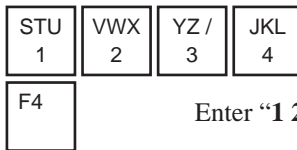

Enter "1 2 3 4" again and press ENTER (F4).

(ENTER)

5 AXFA11 : FI-1201
Change to new
password

6 AXFA11 : FI-1201
It changed the state
of protection related
password.

OK

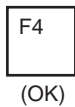

Press OK (F4).

7 AXFA11 : FI-1201
Wrt Protect Menu
1 Write protect Yes
2 Enable Wrt 10min
3-New Password
4 Software seal Keep

SAVE

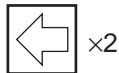

Press ← twice, and return to the "Online" menu.

F0821-2.EPS

Changing Password

Example: Change the password from “1 2 3 4” to “6 7 8 9 A”.

F0822-1.EPS

Open “Wrt protect menu” in the **Hot key** Menu.

Hot key →

2. Wrt Protect Menu →

2. Enable Wrt 10min

1 AXFA11 : FI-1201
Enter current
password to enable to
write for 10
minutes:
[]
[DEL] [ABORT] [ENTER]

“1 2 3 4”

Enter the password and press **ENTER (F4)**.

F4

(ENTER)

2 AXFA11 : FI-1201
Release the write
protection for 10
minutes.
[ABORT] [OK]

F4

Press **OK (F4)**.

Write protect status is released for 10 minutes.

(OK)

3 AXFA11 : FI-1201
If you wish to
release completely,
you have to change
password to all of
spaces.
[ABORT] [OK]

F4

Press **OK (F4)**.

(OK)

4 AXFA11 : FI-1201
Wrt Protect Menu
1 Write protect No
2 Enable Wrt 10min
3-New Password
4 Software seal Keep
[SAVE]

→

or YZ/
3

Select “New Password”.

5 AXFA11 : FI-1201
Enter new password to
change state of write
protect
[]
[DEL] [ABORT] [ENTER]

“6 7 8 9 A”

Enter “6 7 8 9 A” and press **ENTER (F4)**.

F4

(ENTER)

6 AXFA11 : FI-1201
Re-enter new Password
write 30 seconds:
6789A
6789A []
[DEL] [ABORT] [ENTER]

“6 7 8 9 A”

Enter “6 7 8 9 A” again and press **ENTER (F4)**.

F4

(ENTER)

7 AXFA11 : FI-1201
Change to New
password

8 AXFA11 : FI-1201
It changed the state
of protection related
password.
[OK]

F4

Press **OK (F4)**.

(OK)

F0822-2.EPS

```

9 AXFA11 : FI-1201
  Wrt Protect Menu
  1 Write protect Yes
  2 Enable Wrt 10min
  3 New Password
  4 Software seal Keep

  SAVE

```



×2

Press  twice, and return to the “Online” menu.

F0822-3.EPS

**NOTE**

1. “**Enable Wrt 10min**” releases write protection status for 10 minutes. While write protection status is released, it is possible to enter a new password after selecting “**New Password**”. It will not be possible after the 10 minutes have elapsed.
 2. To release write protection status completely, enter 8 spaces in the “**New Password**”. This causes the “**Write protect**” status to change from “**Yes**” to “**No**”.
 3. If the power supply to either the AXFA11 or the HART Communicator are turned off and then on again within 10 minutes after exiting write protection status, the enabled write protection status becomes defunct.
- * “**Joker password**” and “**Software Seal**”
- When you forget the password that you have input, it is possible to release the mode for 10 minutes by setting a joker password in “**Enable Wrt 10 min**”. This joker password can be obtained by contacting your Yokogawa sales office.
- If this joker password is used, the status shown in the parameter “**Software Seal**” is changed from “**Keep**” to “**Break**”. Press Hot key and select “**Wrt Protect Menu**”. Current status is shown in “**Software Seal**”. This status will be returned from “**Break**” to “**Keep**” by registering a new password.

8.3.4.10 Other Functions and Operations

Set any other required parameters in the same way as those previous. Refer to the following document for operation information.

Product Manual for the HART Communicator: MAN 4250

8. OPERATION VIA HART COMMUNICATOR

			Read/Write	Parameter of BRAIN protocol			
4 Detailed setup	4 Function Set	2 Alarm	1 Low Alarm	W	G10		
			2 High Alarm	W	G11		
			3 Low Low Alarm	W	G12		
			4 High High Alarm	W	G13		
			5 H/L Alarm Hys	W	G14		
			6 Alm Out Act Mode	W	G20		
			7 4-20 Alarm Out	W	G21		
			8 4-20 Burn Out	R	G22		
			9 Alm-Setting	W	G30		
			Alm-Sig Over	W	G31		
		Alm-Emp Pipe	W	G32			
		Alm-HH/LL	W	G33			
		Alm-Adhesion	W	G34			
				3 Alm Record	Operation Time	R	G40
					Alm Record1	R	G41
					Alm Record Time1	R	G42
					Alm Record2	R	G43
					Alm Record Time2	R	G44
					Alm Record3	R	G45
		Alm Record Time3	R		G46		
		Alm Record4	R		G47		
		Alm Record Time4	R	G48			
		4 Display Set	1 Display Select1	W	H10/B40		
			2 Display Select2	W	H11/B41		
			3 Display Select3	W	H12/B42		
			4 Display Cycle	W	H20		
			5 Language	W	H30/B10		
		5 Aux	1 4-20mA Low Cut	W	J10		
			2 4-20mA Low Lmt	W	J11		
			3 4-20mA High Lmt	W	J12		
			4 Flow Direction	W	J20		
			5 Rate Limit	W	J21		
			6 Dead Time	W	J22		
			7 Pulsing Flow	W	J23		
			8 T/P Damp Select	W	J24		
			9 Power Synch	W	J30		
			Power Frequency	R/W	J31		
			Memo 1	W	J40		
			Memo 2	W	J41		
			Memo 3	W	J42		
		Software Rev No	R	J50			

(continued on next page)

F0823-3.EPS

8. OPERATION VIA HART COMMUNICATOR

		Read/Write		Parameter of BRAIN protocol
4 Detailed setup	5 HART output	1 Poll addr	PV % range/current Process vars/crnt	
		2 Num req preams		
		3 Burst mode		
		4 Burst option		
6 Device info	1 Field device info	1 Manufacturer	1 Universal rev 2 Fld dev rev 3 Software rev	
		2 Tag		
		3 Descriptor		
		4 Message		
		5 Date		
		6 Device id		
		7 Write protect		
		8 Revision #'s		
	2 Model specific	1 Use		
		2 Lining		
		3 Electrode Material		
		4 Electrode Struct		
		5 Grounding Ring		
		6 Process Connect		
		7 Lay Length		
		8 Electrical Conn		
		9 Sensor Serial No		
5 Review	1 Review1			
	2 Review2			
	3 Review3			
	4 Review4			
Hot key	1 PV Span			W B23/C42
	2 Wrt Protect Menu	1 Write protect		R P20
		2 Enable Wrt 10min		W P21
		3 New Password		W P22
		4 Software Seal		R P23

F0823-4.EPS

9. ACTUAL OPERATION

After you have installed the flowtube into the process piping, wired the input/output terminals, set up the required parameters, and performed a pre-operation zero adjustment, the magnetic flowmeter should output an accurate flow signal from its terminals as soon as flow of the fluid to be measured begins. This section describes zero adjustment and the corresponding procedures.

9.1 Pre-operation Zero Adjustment

Zero adjustment is carried out to ensure that the output for zero flow is 0% (i.e., 4 mA). Although adjustment to zero is performed at the manufacturing plant prior to shipment, this procedure must be carried out once again following the installation of piping in order to match the magnetic flowmeter to its operating conditions.

This section describes the zero adjustment procedure using display unit switches from the converter and using the external status input; accordingly, one of these methods should be selected and implemented.



IMPORTANT

- Zero adjustment should be carried out before actual operation. Note that setting and update functions cannot be carried out during this procedure (i.e., for approximately 30 seconds).
 - Zero adjustment should only be carried out when the flowtube has been filled with fluid and the fluid velocity is completely zero by closing the valve.
 - Each time that the fluid being measured is changed, it will be necessary for zero adjustment to be carried out for the new fluid.
-

9.1.1 Zero Adjustment Using Display Unit Switches

This section describes the procedure for zero adjustment using the display unit switches. (For more details regarding setting methods using these switches, refer to Chapter 5: Basic Operating Procedures.)

The parameters for zero adjustment are **B50/M10: Auto Zero Exe** and either of these can be used to carry out this procedure). For more details regarding these parameters, refer to Chapter 6: Parameter Description.

The parameter **M10: Auto Zero Exe** will be used in the following description.

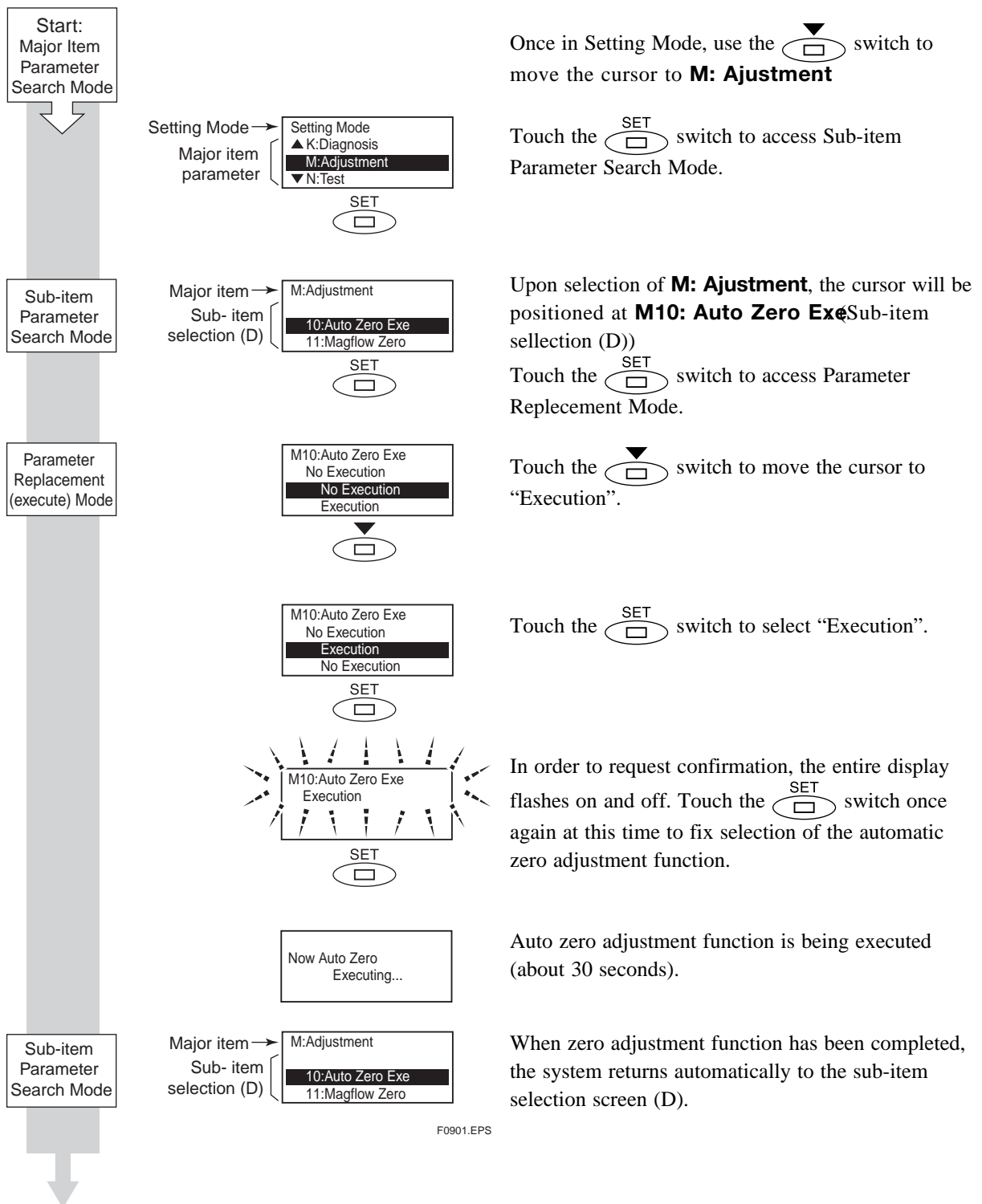

F0901.EPS



NOTE

The results of **M10: Auto Zero Exe** can be displayed using **M11: Magflow Zero**. Alternatively, if the results of the automatic zero adjustment exceed the rated value, the warning **82: Auto Zero Wng** will be displayed.

9.1.2 Zero Adjustment via External Status Input

This section describes the procedure for zero adjustment via external status input. (For more details regarding external status input, refer to Chapter 6: Parameter Description.)



CAUTION

In certain cases where the multiple range function is being used with other status inputs, it may not be possible to perform settings for automatic zero adjustment. For more details, refer to the description of multiple ranges from Chapter 6: Parameter Description.

In order to carry out zero adjustment via external status input, it will be necessary to set “Ext Auto Zero” using either **F12: SI1 Function** or **F13: SI2 Function**. The parameter **F12: SI1 Function** will be used in the following description.

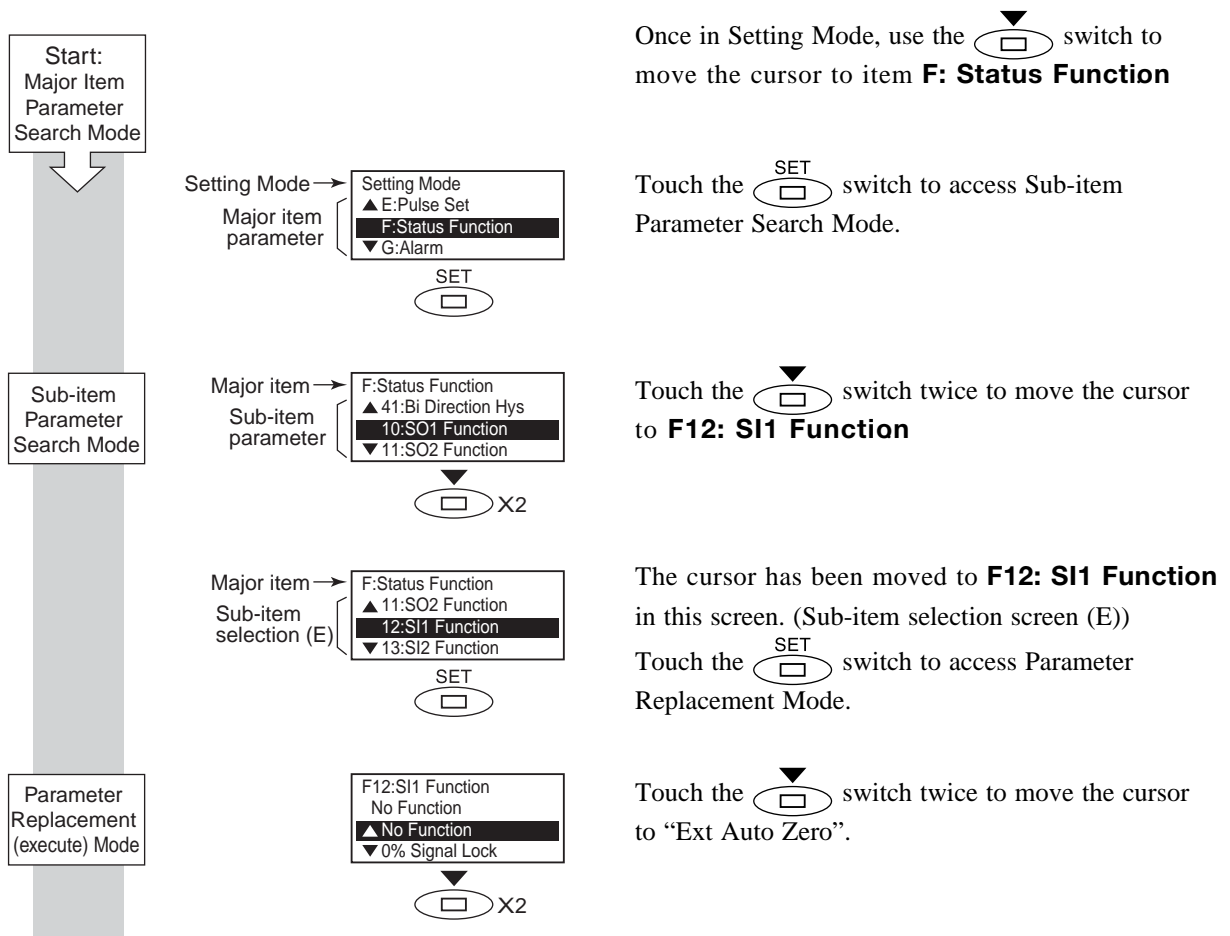

F0902-1.EPS

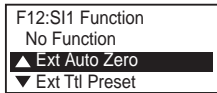

Touch the  switch to select “Ext Auto Zero (Zero adjustment via external status input)”.

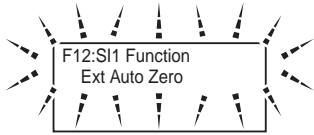

In order to request confirmation, the entire display flashes on and off. Touch the  switch once again at this time to fix selection of the automatic zero adjustment function.

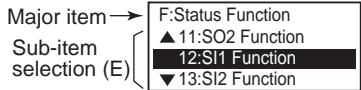

F0902-2.EPS

The system returns automatically to sub-item selection screen (E).

Zero adjustment will be started if the SI1 terminals are shorted (When the active mode has been set to “Short Active” using **F15: SI1/2 Active Mode**

This process will end after approximately 30 seconds.

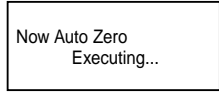

F0902-3.EPS

Auto zero adjustment function is being executed. (about 30 seconds.)



NOTE

When the SI1 terminals continue to be shorted, this zero adjustment is automatically repeated.

10. MAINTENANCE

10.1 Components Replacement



WARNING

- Component replacement and the associated operations must be carried out by expert engineer or skilled personnel and not by operators.
- Before opening the cover, it is important to ensure that at least 10 minutes have passed since the power was turned off. Furthermore, opening of the cover must also be carried out by a expert engineer or skilled personnel.



IMPORTANT

- As a rule, maintenance of this flowmeter should be implemented in a maintenance service shop where the necessary tools are provided.
- The amplifier assembly contains sensitive parts that may be damaged by static electricity. Exercise care so as not to directly touch the electronic parts or circuit patterns on the board, for example, by preventing static electrification by using grounded wrist straps when handling the assembly. Also take precautions such as placing a removed amplifier assembly into a bag with an antistatic coating.

10.1.1 Fuse Replacement



CAUTION

Be sure to turn off the power before performing fuse replacement. Also be sure to use the spare fuse that was supplied with the product, or ones supplied by Yokogawa's sales or service offices.

The fuse holder is located on the lower side of the terminal block. Press this holder upwards and turn it counterclockwise to remove it; then, replace the holder's fuse. Note that the fuse holder must be pressed upwards and turned clockwise when it is being reassembled. A spare fuse is secured by tape to the inside of the case's left side.

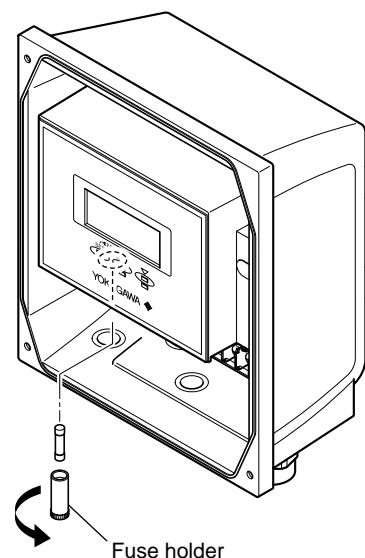

F1001.EPS

Figure 10.1.1 Fuse Assembly

10.1.2 Display Unit Replacement

10.1.2.1 Removing the Display Unit

- (1) Turn off the power.
- (2) Remove the cover.
- (3) Hold the display unit with your hand and remove the two mounting screws. Remove the connector by lifting it upward, taking care not to damage it.

10.1.2.2 Assembling the Display Unit

- (1) Align the display unit with the protrusion of the connector facing forward and then make the required connection.
- (2) Secure the unit using its two mounting screws.
- (3) Replace the cover.

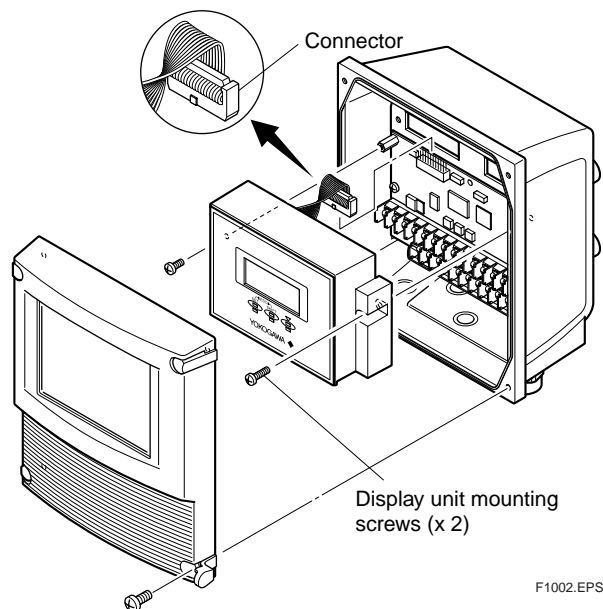

Figure 10.1.2 Display Unit Assembly

10.1.3 Amplifier Replacement



IMPORTANT

In case of amplifier replacement, it is necessary to perform the parameter resetting. For parameters, refer to Chapter 6: Parameter Description.

- (1) Turn off the power.
- (2) Remove the cover.
- (3) Remove all cables that are connected to the terminals.
- (4) Remove the display unit as described in Section 10.1.2.1.
- (5) Loosen the amplifier assembly's four screws while supporting it with your hand (See Figure 10.1.3).
- (6) Pull the amplifier assembly straight out.
- (7) When reassembling the amplifier assembly, return it to its original position and secure it in place using the reverse procedure to that described above.

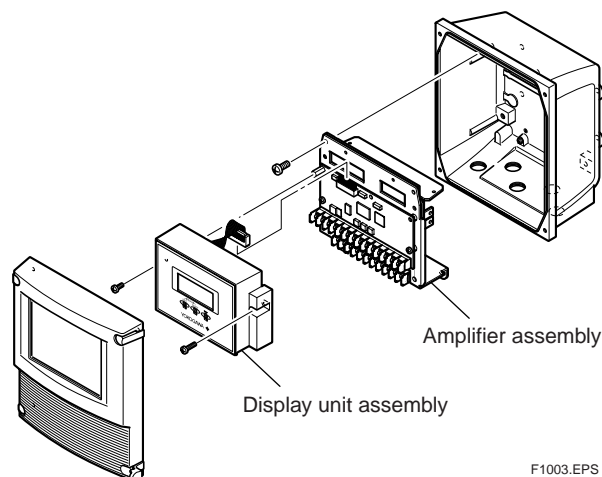

Figure 10.1.3 Amplifier Assembly

10.2 Setting of Switches

10.2.1 Setting of Burnout Switch

The burnout function sets the direction of current output in situations where the CPU has become damaged. Upon shipment from the manufacturing plant, the burnout direction is set to High (i.e., 25 mA); however, in cases where the optional code C1 has been specified, the output direction will be set to Low (i.e., 0 mA).

Modification of the burnout direction must be carried out using the setting switch from the amplifier's CPU board (i.e. Switch 1) (See Figure 10.1.4).

Table 10.1 Output Setting Pins for Burnout

Position of Pin	Burnout Direction	Output	Remarks
<div style="display: flex; justify-content: space-between; width: 100%;"> Low High </div>	High	25 mA	Set to High before shipment
<div style="display: flex; justify-content: space-between; width: 100%;"> Low High </div>	Low	0 mA	Set to Low for optional code C1

T1001.EPS



NOTE

On the amplifier's CPU board, the burnout setting switch (i.e., Switch 1) and the write protect switch (i.e., Switch 2) are located adjacent to each other. Accordingly, special care should be taken when making switch settings.

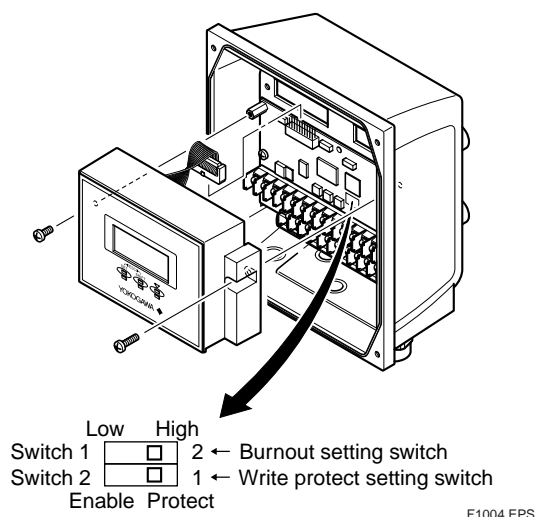

Figure 10.1.4 Switch Configuration

10.2.2 Setting of Write Protect Switch

By setting the write protect function to “Protect” it is possible to prevent the overwriting of parameters. Write protection can be carried out using either the hardware switch on the CPU board (i.e., Switch 2) or software parameter settings. If either of these items is set to “Protect”, the overwriting of parameters will be prohibited.



NOTE

If the hardware switch is set to “Protect”, it will not be possible to overwrite parameters; furthermore, this condition will be maintained until the switch is set to “Enable”.

For more details regarding usage of the write protect function and the software’s parameter switches, refer to Chapter 6: Parameter Description.

10.3 Troubleshooting

Although magnetic flowmeters rarely require maintenance, failures may occur when the instrument is not operated correctly. This section describes troubleshooting procedures where the cause of the breakdown is identified through receiver indication.

10.3.1 No Indication

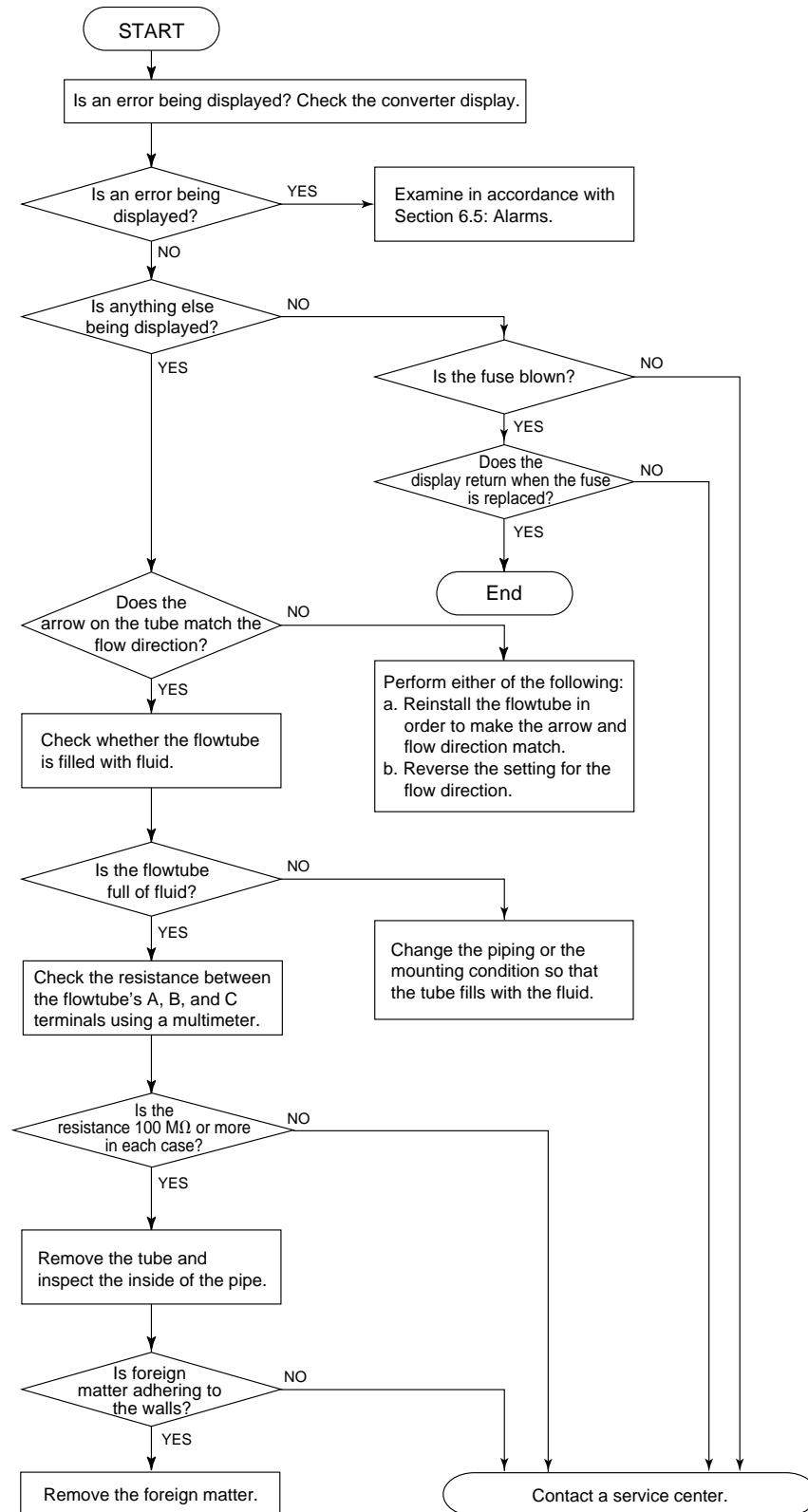

F1005.EPS

10.3.2 Unstable Zero

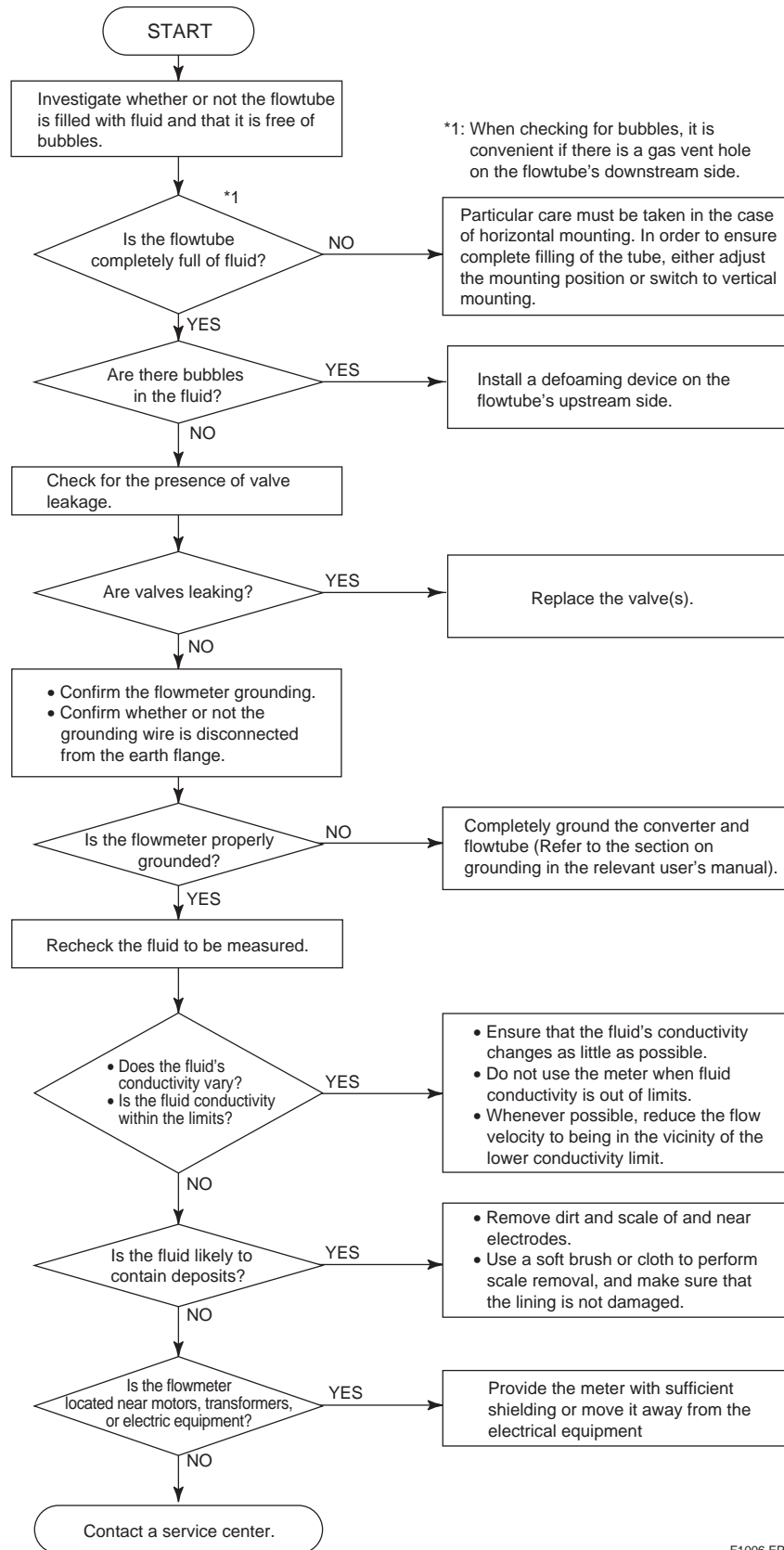

F1006.EPS

10.3.3 Disagreement Between Indication and Actual Flow

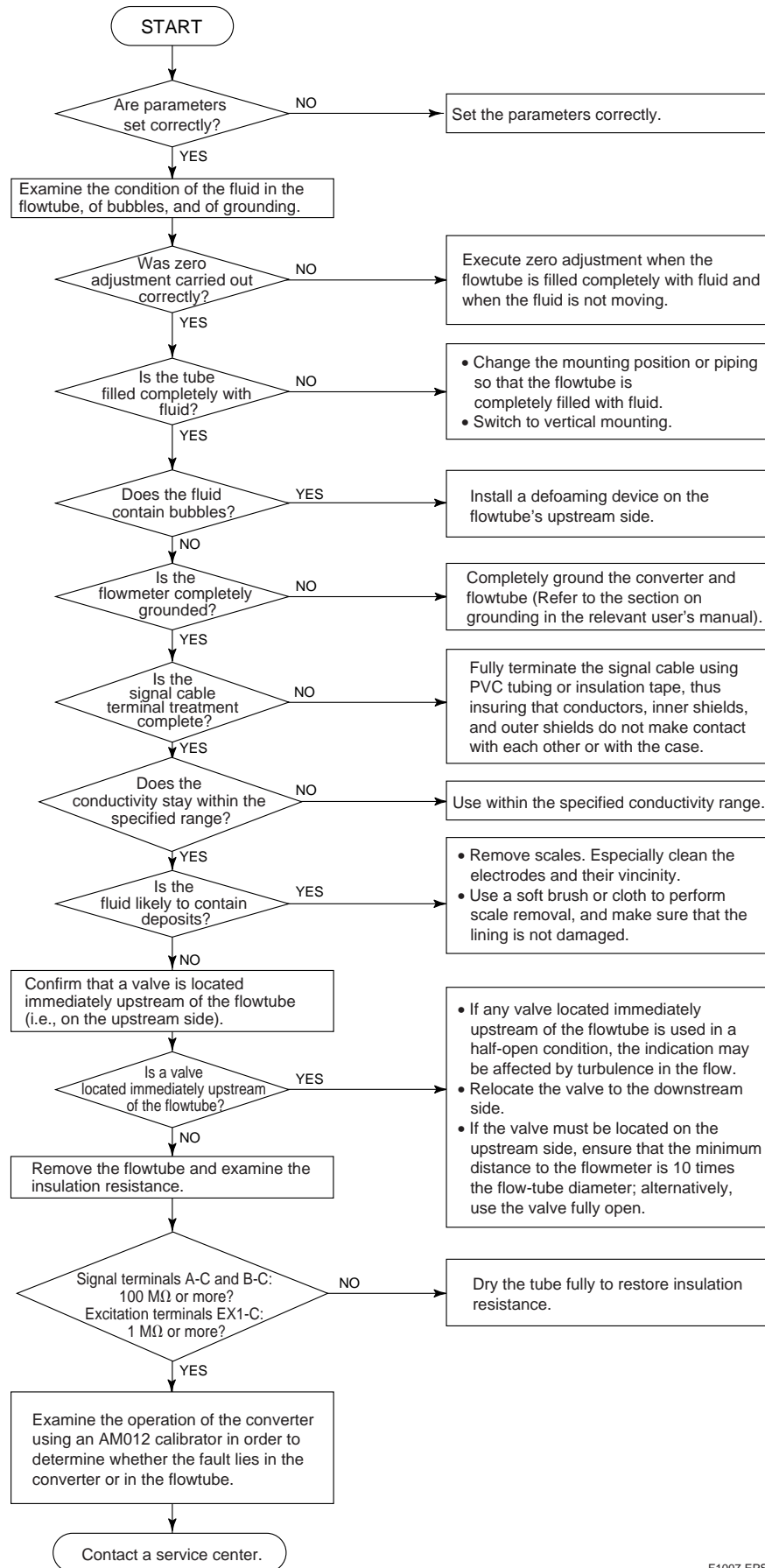

F1007.EPS

11. OUTLINE

■ STANDARD SPECIFICATIONS

Excitation Method: (Combined with AXF Remote Flowtube)

- Standard dual frequency excitation:
Size 2.5 to 400 mm (0.1 to 16 in.)
- Enhanced dual frequency excitation:
Size 25 to 200 mm (1.0 to 8.0 in.)
(Optional code HF1 or HF2)
- Pulsed DC excitation:
Size 500 to 2600 mm (20 to 104 in.)

Input Signal:

Two Status Inputs: Dry contact
Load resistance: 200 Ω or less (ON), 100 k Ω or more (OFF)

Output Signals:

- One Current Output: 4 to 20 mA DC (load resistance: 1k Ω maximum, including cable resistance)
- One Pulse Output:
Transistor contact output (open collector)
Contact capacity: 30 V DC (OFF), 200 mA (ON)
Output rate: 0.0001 to 10,000 pps (pulse/second)
- One Alarm Output:
Transistor contact output (open collector)
Contact capacity: 30 V DC (OFF), 200 mA (ON)
- Two Status Outputs:
Transistor contact output (open collector)
Contact capacity: 30 V DC (OFF), 200 mA (ON)

Communication Signals:

BRAIN or HART communication signal
(Superimposed on the 4 to 20 mA DC signal)
Distance from Power Line: 15 cm (6 in.) or more (Parallel wiring should be avoided.)

BRAIN:

Communication Distance:

Up to 2 km (1.25 miles), when polyethylene insulated PVC-sheathed cables (CEV cables) are used.
Communication distance varies depending on the type of cable and wiring used.

Load Resistance:

250 to 600 Ω (including cable resistance)

Load Capacitance:

0.22 μ F or less

Load Inductance:

3.3 mH or less

Input Impedance of Communicating Device:

10 k Ω or more (at 24 kHz)

HART:

Communication Distance:

Up to 1.5 km (0.9 mile), when using multiple twisted pair cables. Communication distance varies depending on the type of cable used.

Load Resistance:

230 to 600 Ω (including cable resistance)

Cable Length for Specific Applications:

Use the following formula to determine the cable length for specific applications:

$$L = \frac{65 \times 10^6}{(R \times C)} - \frac{(C_f + 10,000)}{C}$$

where:

- L = length in meters or feet
- R = resistance in Ω (including barrier resistance)
- C = cable capacitance in pF/m or pF/ft
- C_f = maximum shunt capacitance of receiving devices in pF/m or pF/ft

Note: HART is a registered trademark of the HART Communication Foundation.

Data Security During Power Failure:

Data (parameters, totalizer value, etc.) storage by EEPROM. No back-up battery required.

Indicator:

Full dot-matrix LCD (32 \times 132 pixels)

Lightning Protector:

The lightning protector is built into the excitation current output, the current output, the signal common, and the pulse/alarm/status input and output terminals. When optional code A is selected, the lightning protector is built into the power terminals.

Protection:

IP66, IP67, JIS C0920 immersion-proof type

Coating:

Case and Cover: Polyurethane corrosion-resistant
Coating Color: Silver gray (Munsell 3.2PB 7.4/1.2 or its equivalent)
Cover Mounting Screws: Polyurethane corrosion-resistant
Coating Color: Mint green (Munsell 5.6BG 3.3/2.9 or its equivalent)

Converter Material:

Case and Cover: Aluminum alloy

Mounting/Shapes:

- Mounting: 2-inch pipe, panel or surface mounting
- Electrical Connection: ANSI 1/2 NPT female
ISO M20 \times 1.5 female
JIS G1/2 (PF1/2) female
- Terminal Connection: M4 size screw terminal

Grounding:

Grounding resistance 100 Ω or less
When optional code A is selected, grounding resistance 10 Ω or less shall be applied.

Combined Remote Flowtube:

- AXFA11 Converter can be combined with size 2.5 to 2600 mm (0.1 to 104 in.) of AXF Remote Flowtube. However, the AXFA11 converter cannot combine with AXF Remote Flowtube of T11S flame proof type (In this case, use the AXFA14 converter).
- If a combined converter is changed from AXFA11 to AXFA14 or vice versa, a new meter factor must be adjusted by flow calibrations.

Functions

How to Set Parameters:

The indicator's LCD and three infra-red switches enable users to set parameters without opening the case cover. Parameters can also be set by means of the HHT(Hand-held terminal).

Displayed Languages:

Users can choose a language from among English, Japanese, German, French, Italian, Spanish.

Instantaneous Flow Rate/Totalized Value Display Functions:

The full dot-matrix LCD enables user selections of displays from one line to three lines for:

- Instantaneous flow rate
- Instantaneous flow rate (%)
- Instantaneous flow rate (bar graph)
- Current output value (mA)
- Totalized value
- Tag No.
- Results of electrode adhesion diagnostics

Totalizer Display Function:

The flow rate is counted one pulse at a time according to the setting of totalization pulse weights. For forward and reverse flow measurement functions, the totalized values of the flow direction (forward or reverse) and the flow direction are displayed on the indicator together with the units. The difference of totalized values between the forward and reverse flow rate can be displayed. Totalization for the reverse flow rate is carried out only when "Forward and reverse flow measurement functions" is selected.

Damping Time Constant:

Time constant can be set from 0.1 second to 200.0 seconds (63% response).

Span Setting Function:

Span flows can be set in units such as volume flow rate, mass flow rate, time, or flow rate value. The velocity unit can also be set.

Volume Flow Rate Unit: kcf, cf, mcf, Mgal (US), kgal (US), gal (US), mgal (US), kbbbl (US)*, bbl (US)*, mbbbl (US)*, μbbbl (US)*, MI (megaliter), m³, kl (kiloliter), l (liter), cm³

Mass Flow Rate Unit (Density must be set.): klb (US), lb (US), t (ton), kg, g

Velocity Unit: ft, m (meter)

Time Unit: s (sec), min, h (hour), d (day)

* "US Oil" or "US Beer" can be selected.

Pulse Output:

Scaled pulse can be output by setting a pulse weight.

Pulse Width: Duty 50% or fixed pulse width (0.05, 0.1, 0.5, 1, 20, 33, 50, 100 ms) can be selected.

Output Rate: 0.0001 to 10,000 pps (pulse/second)

Multi-range Function:

- Range switching via status input
Status input enables the switching of up to four ranges.
- Automatic range switching
When the flow rate exceeds 100 % of the range, transition to the next range (up to four ranges) is carried out automatically. Range switching can be confirmed by status outputs and indicator.

Forward and Reverse Flow Measurement Functions:

Flows in both forward and reverse directions can be measured. The reverse flow measurement can be confirmed by status output and indicator.

Totalization Switch:

The status output is carried out when a totalized value becomes equal to or greater than the set value.

Preset Totalization:

The parameter setting or status input enables a totalized value to be preset to a setting value or zero.

0% Signal Lock:

Status input forcibly fixes the instantaneous flow rate display, current output, pulse output, and flow rate totalization to 0%.

Alarm Selection Function:

Alarms are classified into System Alarms (hard failures), Process Alarms (such as 'Empty Pipe', 'Signal Overflow' and 'Adhesion Alarm'), Setting Alarms, and Warnings. Whether alarms should be generated or not can be selected for each item.

The current output generated for an alarm can be selected from among 2.4 mA or less, fixed to 4 mA, 21.6 mA or more, or HOLD.

Alarm Output:

Alarms are generated only for the items selected via the 'Alarm Selection Function' if relevant failures occur.

Self Diagnostics Functions:

If alarms are generated, details of the System Alarms, Process Alarms, Setting Alarms and Warnings are displayed together with concrete descriptions of counter-measures.

Flow Upper/Lower Limit Alarms:

If a flow rate becomes greater or smaller than the set value, this alarm is generated. In addition, two upper limits (H, HH) and two lower limits (L, LL) can be set.

If a flow rate becomes greater or smaller than any of the set values, the status is output.

Electrode Adhesion Diagnostics Function:

This function enables monitoring of the adhesion level of insulating substances to the electrodes. Depending on the status of adhesion, users are notified by a warning or an alarm via status outputs. If replaceable electrodes are used, they can be removed and cleaned when adhesion occurs.

STANDARD PERFORMANCE

Reference Conditions:

- Similar to BS EN 29104 (1993); ISO9104 (1991)
- Fluid Temperature: 20°C ±10°C (+68°F ±18°F)
- Ambient Temperature: 25°C ±5°C (+77°F ±9°F)
- Warm-up Time: 30 min
- Straight runs
 - Upstream > 10 × DN
 - Downstream > 5 × DN
- Properly grounded
- Properly centered

Accuracy (Combined with AXF Remote Flowtube, at reference conditions)

Pulse Output:

PFA/Ceramics Lining:

Size mm (in.)	Flow Velocity V m/s (ft/s)	Standard Accuracy (Calibration code B)	Flow Velocity V m/s (ft/s)	High grade Accuracy (Calibration code C)
2.5 (0.1) to 15 (0.5)	V < 0.3 (1)	±1.0 mm/s	—	—
	0.3 ≤ V ≤ 10 (1) (33)	±0.35% of Rate		
25 (1.0) to 200 (8.0)	V < 0.15 (0.5)	±0.5 mm/s	V < 0.15 (0.5)	±0.5 mm/s
	0.15 ≤ V ≤ 10 (0.5) (33)	±0.35% of Rate	0.15 ≤ V < 1 (0.5) (3.3)	±0.18% of Rate ±0.2mm/s
			1 ≤ V ≤ 10 (3.3) (33)	±0.2% of Rate
250 (10) to 400 (16)	V < 0.15 (0.5)	±0.5 mm/s	—	—
	0.15 ≤ V ≤ 10 (0.5) (33)	±0.35% of Rate		

Enhanced dual frequency excitation (Option code HF2) : T01.EPS
Standard accuracy ± 1 mm/s

Size 2.5 mm (0.1 in.) to 15 mm (0.5 in.)

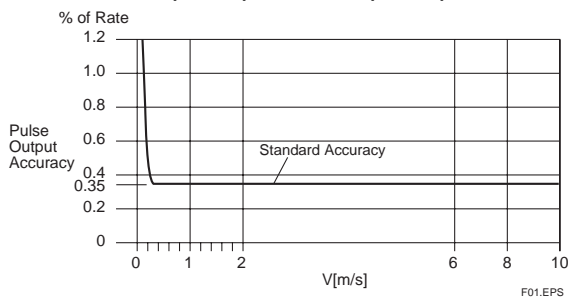

Size 25 mm (1.0 in.) to 400 mm (16 in.)

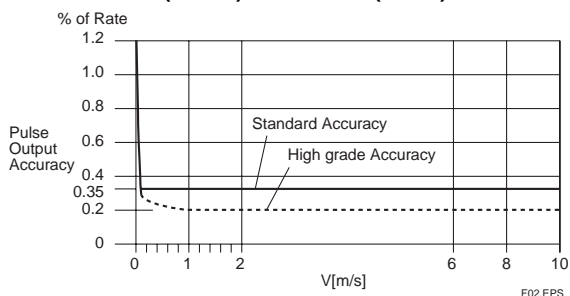

Polyurethane Rubber/Natural Soft Rubber/EPDM Rubber Lining

Size mm (in.)	Flow Velocity V m/s (ft/s)	Standard Accuracy (Calibration code B)
25 (1.0) to 400 (16)	V < 0.3 (1.0)	±1.0 mm/s
	0.3 ≤ V ≤ 10 (1.0) (33)	±0.35% of Rate
500 (20) to 1000 (40)	V < 0.3 (1.0)	±1.75 mm/s
	0.3 ≤ V < 1 (1.0) (3.3)	±0.25% of Rate ±1 mm/s
	1 ≤ V ≤ 10 (3.3) (33)	±0.35% of Rate
1100 (44) to 2000 (80)	V < 0.3 (1.0)	±2.2 mm/s
	0.3 ≤ V < 1 (1.0) (3.3)	±0.4% of Rate ±1 mm/s
2200 (88) to 2600 (104)	1 ≤ V ≤ 10 (3.3) (33)	±0.5% of Rate
	V < 1 (3.3)	±8.5 mm/s
2600 (104)	1 ≤ V ≤ 10 (3.3) (33)	±0.85% of Rate

Enhanced dual frequency excitation (Option code HF2) : T02.EPS
Standard accuracy ± 1 mm/s

Size 25 mm (1.0 in.) to 400 mm (16 in.)

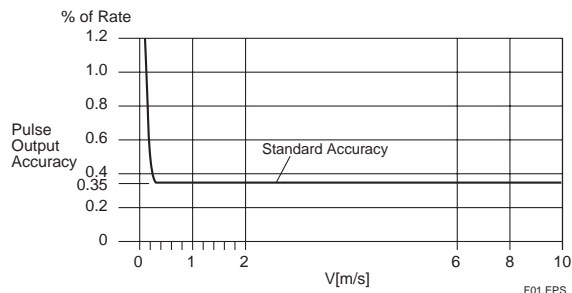

Size 500 mm (20 in.) to 1000 mm (40 in.)

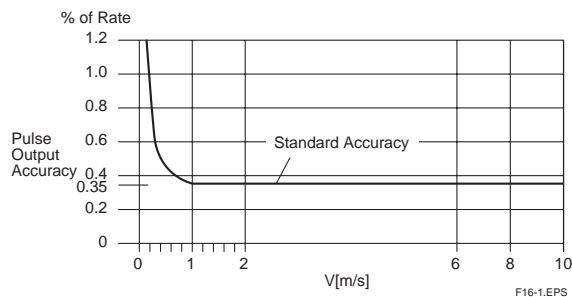

Size 1100 mm (44 in.) to 2000 mm (80 in.)

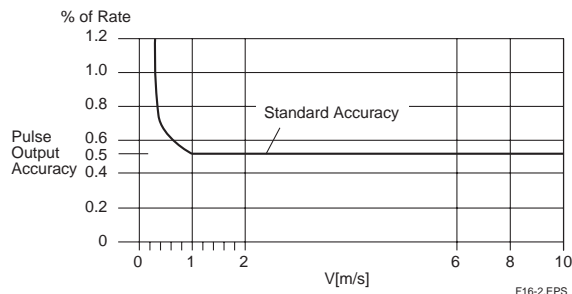

Size 2200 mm (88 in.) to 2600 mm (104 in.)

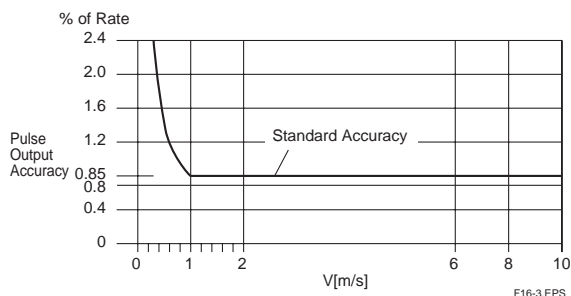

Current Output: Pulse output accuracy plus $\pm 0.05\%$ of Span

Repeatability:

- $\pm 0.1\%$ of Rate ($V \geq 1$ m/s (3.3 ft/s))
- $\pm 0.05\%$ of Rate ± 0.5 mm/s ($V < 1$ m/s (3.3 ft/s))

Maximum Power Consumption:

Combined with AXF Remote Flowtube: 20 W

Insulation Resistance(*1) :

- Between power supply terminals and ground terminal: 100M Ω at 500V DC
- Between power supply terminals and input/output/excitation current terminals : 100M Ω at 500V DC
- Between ground terminal and input/output/excitation current terminals: 20M Ω at 100V DC
- Between input/output/excitation current terminal: 20M Ω at 100V DC

Withstand Voltage(*1) :

- Between power supply terminals and ground terminal: 1390V AC for 2 seconds
- Between power supply terminals and input/output terminals: 1390V AC for 2 seconds
- Between excitation current terminal and ground terminal: 160V AC for 2 seconds
- Between excitation current terminal and input /output terminals: 200V AC for 2 seconds



CAUTION

- *1: When performing the Insulation Resistance Test or the Withstand Voltage Test, please obey the following caution.
- Following the relevant test, wait for more than 10 seconds after the power supply has been turned off before removing the cover.
 - Remove all wires from terminals before testing.
 - When the power terminal has a lighting protector (optional code A), remove the short bar at the ground terminal.
 - After testing, be sure to discharge by using a resistance and return all wires and the short bar to its correct position.
 - Screws must be tightened to a torque of 1.18 N-m or more.
 - After closing the cover, the power supply can be restored.

Safety Requirement Standards:

- EN61010-1
- Altitude at installation site: Max. 2000 m above sea level
- Installation category based on IEC1010: Overvoltage category II ("II" applies to electrical equipment which is supplied from a fixed installation-like distribution board.)
- Pollution degree based on IEC1010: Pollution degree 2 ("Pollution degree" describes the degree to which a solid, liquid, or gas which deteriorates dielectric strength or surface resistivity is adhering. "2" applies to a normal indoor atmosphere.)

EMC Conformity Standards:

- EN61326
- EN61000-3-2, EN61000-3-3
- AS/NZS CISPR11

■ NORMAL OPERATING CONDITIONS

Ambient Temperature: -40°C to $+60^{\circ}\text{C}$ (-40°F to $+140^{\circ}\text{F}$)
Indicator's operating range: -20°C to $+60^{\circ}\text{C}$ (-4°F to $+140^{\circ}\text{F}$)

Ambient Humidity: 0 to 100%

Lengthy continuous operation at 95% or more is not recommended.

Power Supply:

Power supply code 1:

- AC specifications
Rated power supply: 100 to 240 V AC, 50/60 Hz
(Operating voltage range: 80 to 264 V AC)
- DC specifications
Rated power supply: 100 to 120 V DC
(Operating voltage range: 90 to 130 V DC)

Power supply code 2:

- AC specifications
Rated power supply: 24 V AC, 50/60 Hz
(Operating voltage range: 20.4 to 28.8 V AC)
- DC specifications
Rated power supply: 24 V DC
(Operating voltage range: 20.4 to 28.8 V DC)

Supplied Power and Cable Length for Power Supply Code 2

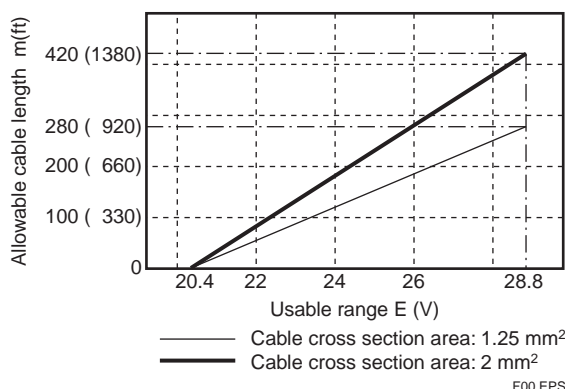

Vibration Conditions:

Level of vibration in conformity with IEC 60068-2-6 (SAMA31. 1-1980)
0.5 G or less (frequency 500 Hz or less)

Note: Avoid locations with much vibration (with a vibration frequency of 500 Hz or more), which may cause damage to the equipment.

■ ACCESSORIES

Fuse (Time lag fuse): 1 pc.

- Power supply code 1; T2.5 A, 250 V
- Power supply code 2; T3.15A, 250 V

Mounting bracket: 1 set

■ MODEL AND SUFFIX CODE

AXFA11 Magnetic Flowmeter Remote Converter:

Model	Suffix Code	Description
AXFA11		Magnetic Flowmeter Remote Converter
Use	G	General-Purpose Use For AXF Remote Flowtube of size 2.5 to 2600 mm (0.1 in. to 104 in.)
Output Signal and Communication	-D	4 to 20 mA DC, BRAiN Communication
	-E	4 to 20 mA DC, HART Communication
Power Supply	1	100 V to 240 V AC or 100 to 120 V DC
	2	24 V AC/DC (*)
Electrical Connections	-0	JIS G1/2 female
	-2	ANSI 1/2 NPT female
	-4	ISO M20 × 1.5 female
Indicator	1	With Indicator
Option	/□	Optional code (See the Table of Optional Specifications)

T03.EPS

*1: In case of power supply code 2 (24 V AC/DC), optional code A (lighting protector) is mandatory.

Signal Cable:

Model	Suffix Code	Description
AXFC	Magnetic Flowmeter Dedicated Signal cable for the ADMAG AXF series
Termination	-0	No Termination. A set of termination parts for M4 screws is attached.
	-4	Terminated for the AXFA11/14 Converter.
Cable Length	-L□□□	Designate the cable length, unit: m Following "L", specify the cable in three digits as multiple of 1 meter (e.g., 001, 002, or 005) for a length up to 5 m, or as a multiple of 5 meters (i.e., 005, 010, 015, or the like). The maximum cable length: 200 m for combined use with AXFA11 100 m for combined use with AXFA14
Option	/C□	With termination parts sets. Following "C", specify the q'ty of sets of termination parts in one digits.

T04.EPS

- Note:
- The cable is constructed with double shielding over the two conductors, and uses heat-resistant vinyl as the outer covering material.
Finished diameter: 10.5 mm (0.413 in.)
Maximum temperature: +80°C (+176°F)
 - Unnecessary to order the above cable for submersible type flowtube or for the optional code DHC flowtube because the flowtube is wired with 30 m (98 ft) cable.
 - For excitation cable, prepare a two-core cable at the customer side.

■ OPTIONAL SPECIFICATIONS FOR AXFA11 REMOTE CONVERTER

Item	Specification	Code
Lightning Protector	A lightning protector is built into the power terminals. In case of power supply code 2 (24 V AC/DC), this optional code is mandatory.	A
DC Noise Cut Circuit	The DC Noise Cut Circuit is built in. Available for 15 mm (0.5 in.) and larger sizes, and for fluids with the conductivity of 50 μS/cm or higher. Nullifies the empty check and electrode adhesion diagnostics function.	ELC
Burn Out Down	The output level is set to 0 mA during a CPU failure and is set 2.4 mA (-10%) or less during an alarm. Standard products are delivered with a setting 25 mA during a CPU failure and 21.6 mA (110%) or more during an alarm.	C1
NAMUR NE43 Compliance	Output signal limits: 3.8 to 20.5 mA	C2
	Failure alarm down-scale: The output level is set to 0 mA during a CPU failure and is set 2.4 mA (-10%) or less during an alarm. Failure alarm up-scale: The output level is set to 25 mA during a CPU failure and is set 21.6 mA (110%) or more during an alarm.	C3
Active Pulse Output	Active pulses are output in order to drive an external electromagnetic or electronic counter directly using the converter's internal power supply. (Nullifies the standard transistor contact pulse output.) Output voltage: 24 V DC ±20% Pulse specifications: • The drive current of 30 to 150 mA • Pulse rate: 0.0001 to 2 pps (pulse/second); Pulse width: 20, 33, 50, or 100 ms	EM
G3/4 Female Waterproof Glands	Waterproof glands for G3/4 conduits or flexible tubes are attached to the electrical connections. Available only for JIS G1/2 electric connections.	EW
Waterproof Glands	Waterproof glands are attached to the electrical connections. Available only for JIS G1/2 electric connections.	EG
Waterproof Glands with Union Joints	Waterproof glands with union joints are attached to the electrical connections. Available only for JIS G1/2 electric connections.	EU
Plastic Glands	Plastic glands are attached to the electrical connections. Available only for JIS G1/2 electric connections.	EP
Air Purge Fitting	Provided with an air purge fitting (1.5 L/min air consumption) with purge air pressure at 0.14 MPa or less. 1/4 NPT female (when electrical conn. code is 2 or 4) or Rc1/4 (PT 1/4) female (when electrical conn. code is 0).	APC
Stainless Steel Mounting Bracket	Provided with a JIS SUS304 (AISI 304 SS/EN 1.4301 equivalent) stainless steel mounting bracket in lieu of the standard carbon steel bracket.	SB
AM11 Replacement Bracket	Provided with a special mounting bracket for replacing an AM11 converter with an AXFA11.	RK
Stainless Steel Tag Plate	Screwed JIS SUS304 (AISI 304 SS/EN 1.4301 equivalent) stainless steel tag plate. Choose this option when an SS tag plate is required in addition to the standard nameplate with the tag number inscribed on it. Dimension (Height × Width): Appr. 12.5 (4.92) × 40 (15.7) mm (inch)	SCT
Painting Color Change	Coated in black (Munsell N1.5 or its equivalent.)	P1
	Coated in jade green (Munsell 7.5BG4/1.5 or its equivalent.)	P2
	Coated in metallic silver.	P7
Epoxy Resin Coating	Epoxy resin coating which has alkali-resistance instead of standard polyurethane resin coating. The color is same as standard type.	X1
High Anti-corrosion Coating	Three-layer coating (polyurethane coating on two-layer epoxy resin coating) in the same range as that for the standard coating. The color is same as standard type. Salt/alkali/acid/weather-	X2
Calibration Certificate	Level 2: The Declaration and the Calibration Equipment List are issued.	L2
	Level 3: The Declaration and the Primary Standard List are issued.	L3
	Level 4: The Declaration and the Yokogawa Measuring Instruments Control System are issued.	L4

T05.EPS

● Terminal Configuration

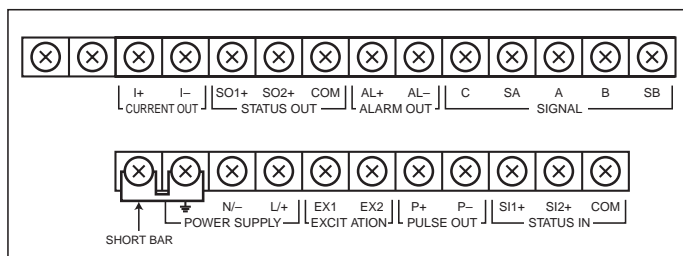

T06.EPS

● Terminal Wiring

Terminal Symbols	Description	Terminal Symbols	Description
SIGNAL [C, SA, A, B, SB]	Flow signal input	STATUS IN [SI1+, SI2+, COM]	Status input (Two input)
ALARM OUT [AL+, AL-]	Alarm output	PULSE OUT [P+, P-]	Pulse output
STATUS OUT [SO1+, SO2+, COM]	Status output (Two output)	EXCITATION [EX1, EX2]	Excitation current output
CURRENT OUT [I+, I-]	Current output 4 to 20mA DC	POWER SUPPLY [L+, N-]	Power supply
		[Grounding symbol]	Functional grounding
		[Grounding symbol]	Protective grounding (Outside of the terminal)

T07.EPS

EXTERNAL DIMENSIONS

Remote Converter AXFA11G

Unit: mm
(approx. inch)

Pipe mounting

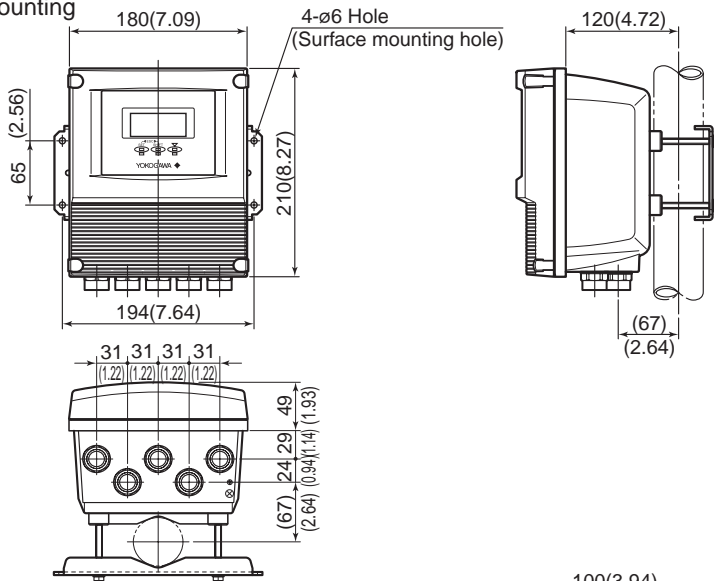

Weight 3.3 kg (7.3 lb)

Panel mounting

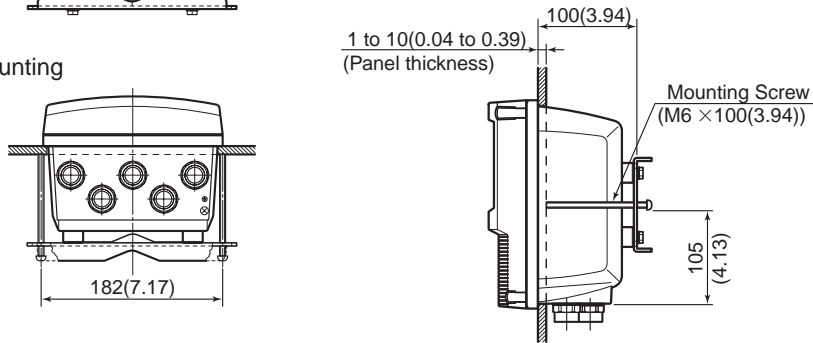

Surface mounting

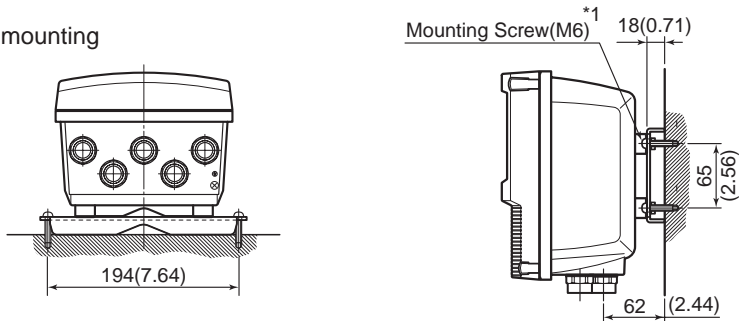

*1: These screws must be provided by the user.

T08.EPS

● Remote Converter AXFA11G /RK (AM11 Replacement Bracket)

Pipe mounting

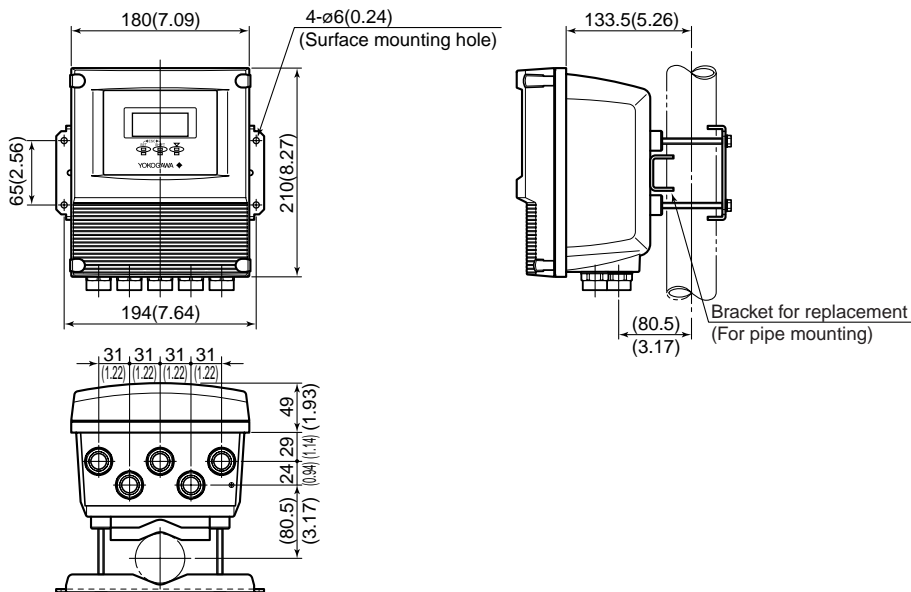

Surface mounting

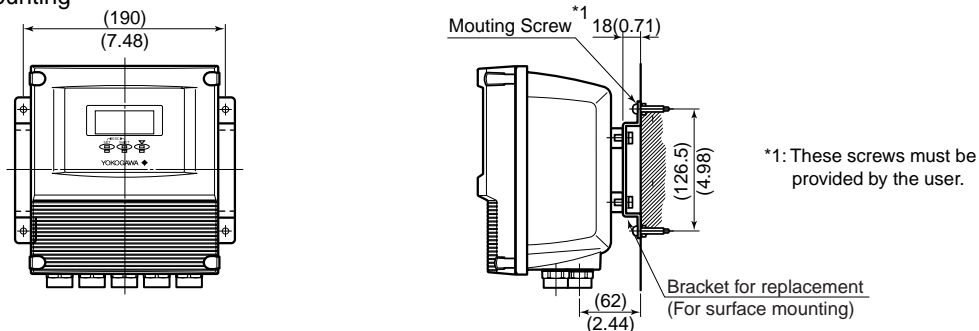

FF0AXFA11E.EPS

● Unless otherwise specified, difference in the dimensions are refer to the following table.

General tolerance in the dimensional outline drawing.

Unit : mm (approx.inch)

Category of basic dimension		Tolerance	Category of basic dimension		Tolerance
Above	Equal or below		Above	Equal or below	
	3 (0.12)	±0.7 (±0.03)	500 (19.69)	630 (24.80)	±5.5 (±2.17)
3 (0.12)	6 (0.24)	±0.9 (±0.04)	630 (24.80)	800 (31.50)	±6.25 (±0.25)
6 (0.24)	10 (0.39)	±1.1 (±0.04)	800 (31.50)	1000 (39.37)	±7.0 (±0.28)
10 (0.39)	18 (0.71)	±1.35 (±0.05)	1000 (39.37)	1250 (49.21)	±8.25 (±0.32)
18 (0.71)	30 (1.18)	±1.65 (±0.06)	1250 (49.21)	1600 (62.99)	±9.75 (±0.38)
30 (1.18)	50 (1.97)	±1.95 (±0.08)	1600 (62.99)	2000 (78.74)	±11.5 (±0.45)
50 (1.97)	80 (3.15)	±2.3 (±0.09)	2000 (78.74)	2500 (98.43)	±14.0 (±0.55)
80 (3.15)	120 (4.72)	±2.7 (±0.11)	2500 (98.43)	3150 (124.02)	±16.5 (±0.65)
120 (4.72)	180 (7.09)	±3.15 (±0.12)			
180 (7.09)	250 (9.84)	±3.6 (±0.14)			
250 (9.84)	315 (12.40)	±4.05 (±0.16)			
315 (12.40)	400 (15.75)	±4.45 (±0.18)			
400 (15.75)	500 (19.69)	±4.85 (±0.19)			

Remarks: The numeric is based on criteria of tolerance class IT18 in JIS B 0401.

● Dedicated Signal Cable

AXFC-4-L□□□

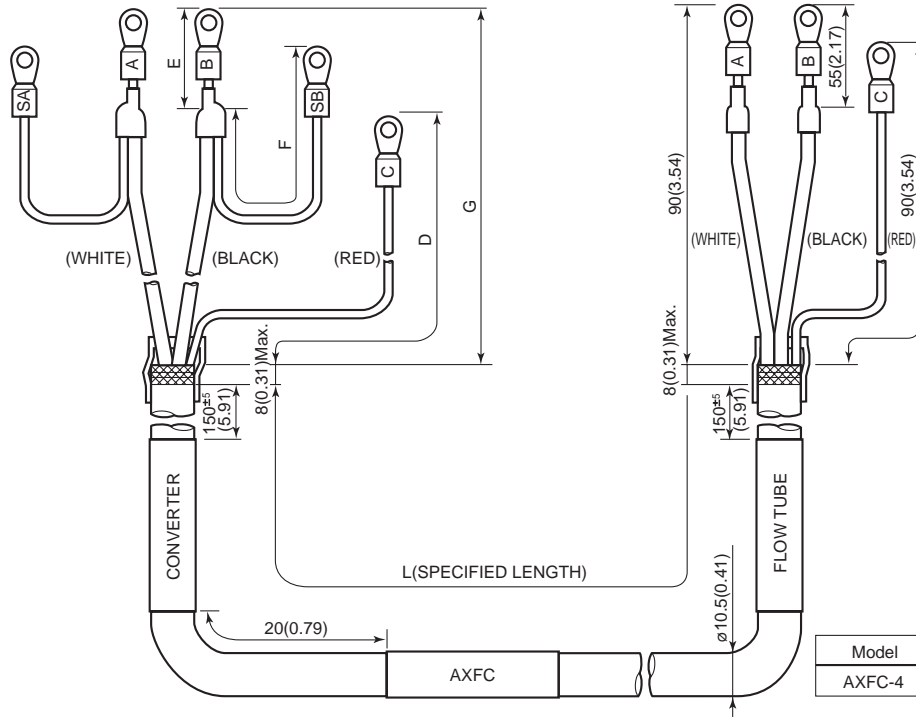

Unit: mm
(approx. inch)

AXFC-0-L□□□

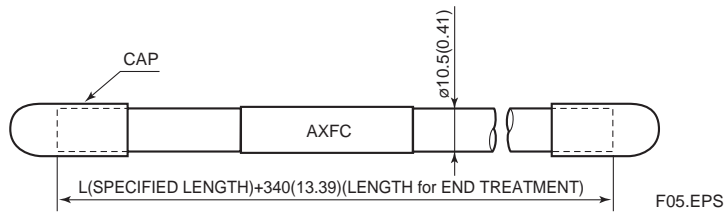

REVISION RECORD

Title: AXFA11G Magnetic Flowmeter Remote Converter
 [Hardware Edition/Software Edition]
 Manual No.: IM 01E20C01-01E

Edition	Date	Page	Revised item	
5th	Oct. 2006	2-1	2.2	Added the fuse of "Power supply code 2 (24 V AC/DC)".
		4-1	4.1	Added the caution note of route the power and output signal cable.
		4-5	4.4.4	Added the important note for a 24 V power supply version (power supply code 2). Added the item "(2) Required Power Supply Voltages".
		4-8		Added the important note on pulse rate range of active pulse output.
		5-1	5.1	Added the important note on operation display unit and write protection function.
		5-3	5.2.1	Corrected the flow chart.
		6-3 to 6-7		Corrected the data range from "0.00001" to "0.0001". (B23, C42, C49, F30 to F36) Corrected the position of decimal point from "0 to 5" to "0 to 4" (B23, B31, B33, C42, C46, C49, D11, E11, F30 to F36)" Corrected the position of decimal point from "0 to 5" to "0 to 2". (C32)
		6-30	J10, J11, J12	Added the sentence about indications action of display unit.
		6-32	J31	Added the parameter setting table for "Power supply code 2".
		7-3	7.2.1	Corrected the "Receiving instrument" of "Figure 7.2" Added the important note on write protection function.
		8-1		Added the important note on write protection function.
		11-1		Corrected the "Protection".
		11-4		Corrected the "Safety Requirement Standards". Corrected the "EMC Conformity Standards". Added the item of "Power supply code 2" to "NORMAL OPERATING CONDITION".
		11-5		Added the fuse of "Power supply code 2 (24 V AC/DC)" to "ACCESSORIES".
		11-6		Added the code "-2 (24 V AC/DC)" to "MODEL AND SUFFIX CODE". Added the note for "Power supply code 2 (24 V AC/DC)" to optional code A (Lightning protector).