

Drawings

Model DC402G [Style: S2] Converter for Dual Cell Conductivity or Resistivity

EXA SC

Unit : mm

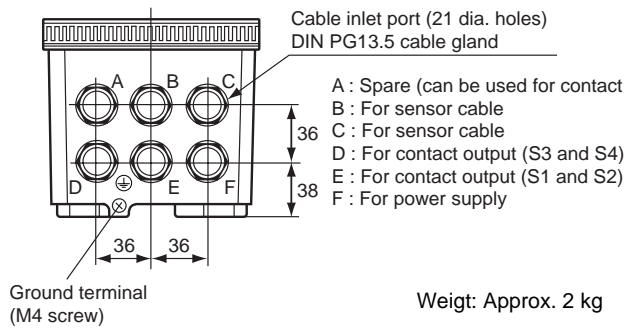
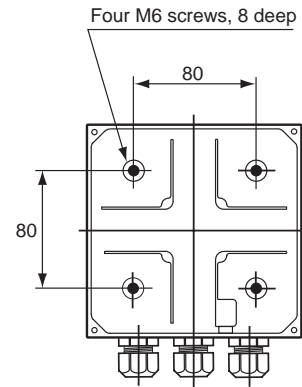
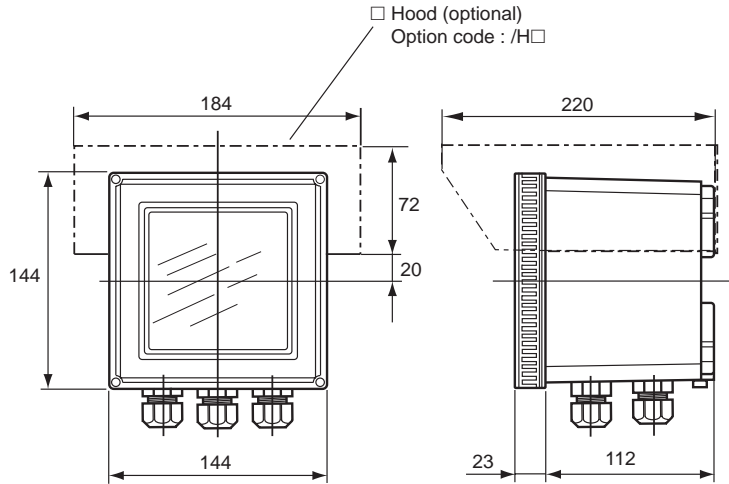

□ Adapter for Conduit Work (optional)
(option code : / AFTG, / ANSI)

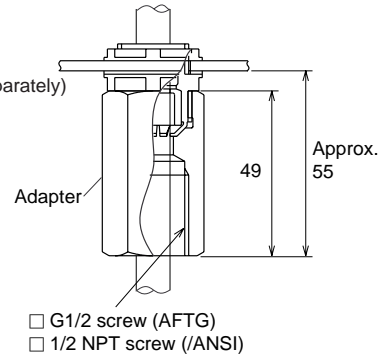

Weight: Approx. 2 kg

Input and Output Connections

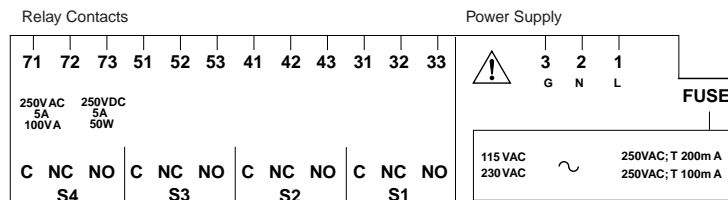
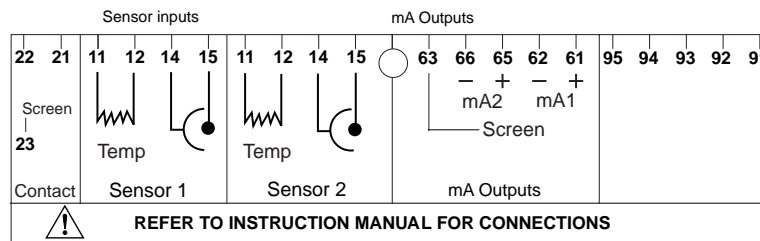

Unless otherwise specified, differences in the dimensions are specified as: General tolerance = ± (Criteria of tolerance class it18 in JIS BO401-1986) / 2.

Unit : mm

□ Pipe Mounting Bracket / Wall Mounting Bracket (option code : /U)

Weight : Approx. 0.7kg

•Example of bracket used for pipe mounting

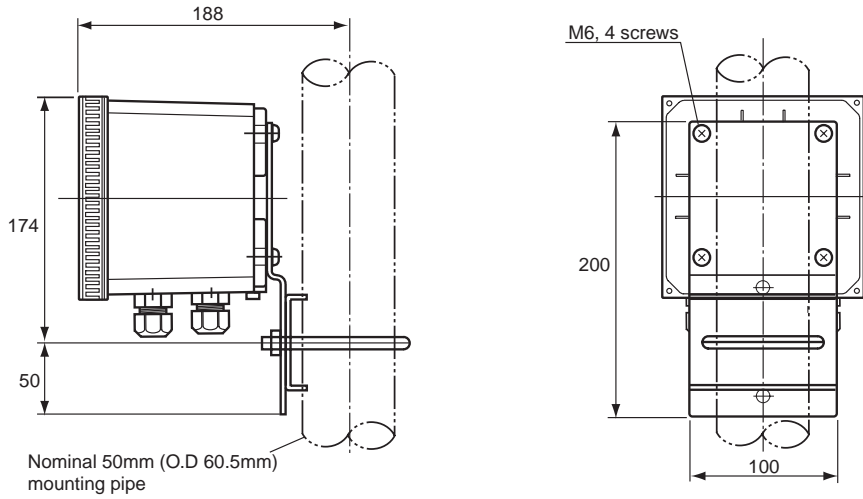

•Example of bracket used for wall mounting

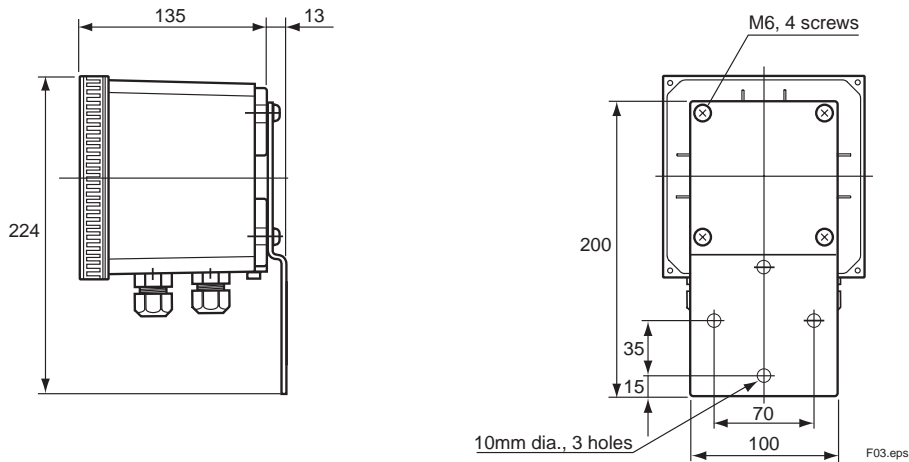

□ Panel Mounting Bracket (option code : / PM)

Weight : Approx. 0.4kg

