

2-wire Dissolved-oxygen Metering system DO202G, DO202S [Style: S2, S3] Transmitter

Unit : mm

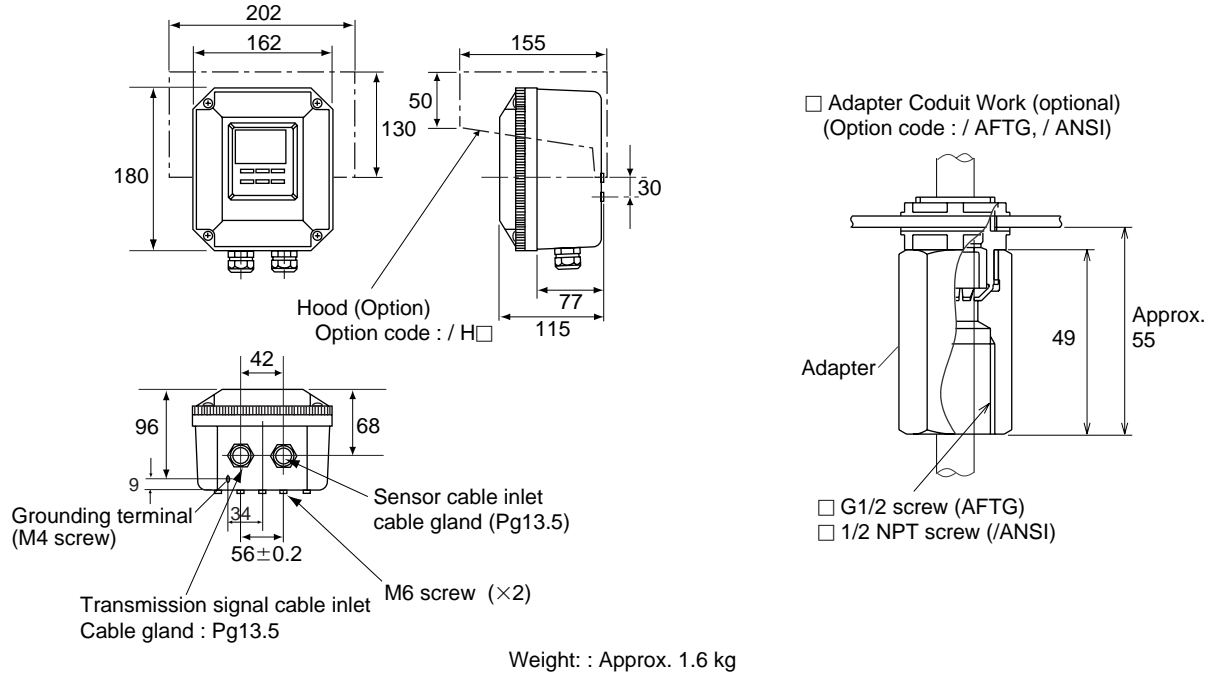

Wiring Diagrams

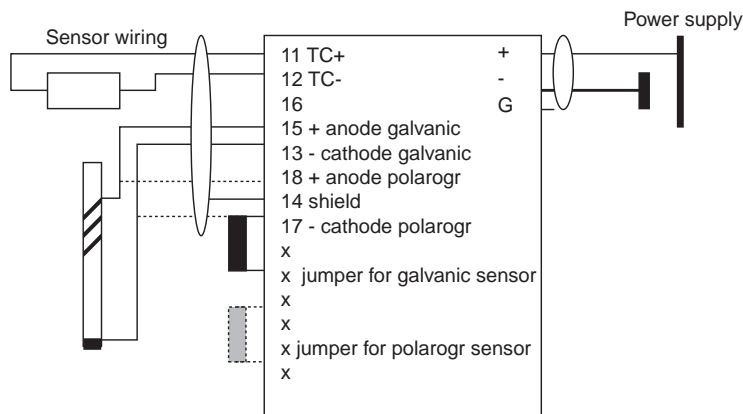

Unless otherwise specified, differences in the dimensions are specified as : General tolerance = ±(Criteria of tolerance class IT18 in JIS B0401 - 1986)/2

□ Pipe Mounting Hardware (Option code : / U)

Weight : Approx. 0.4kg

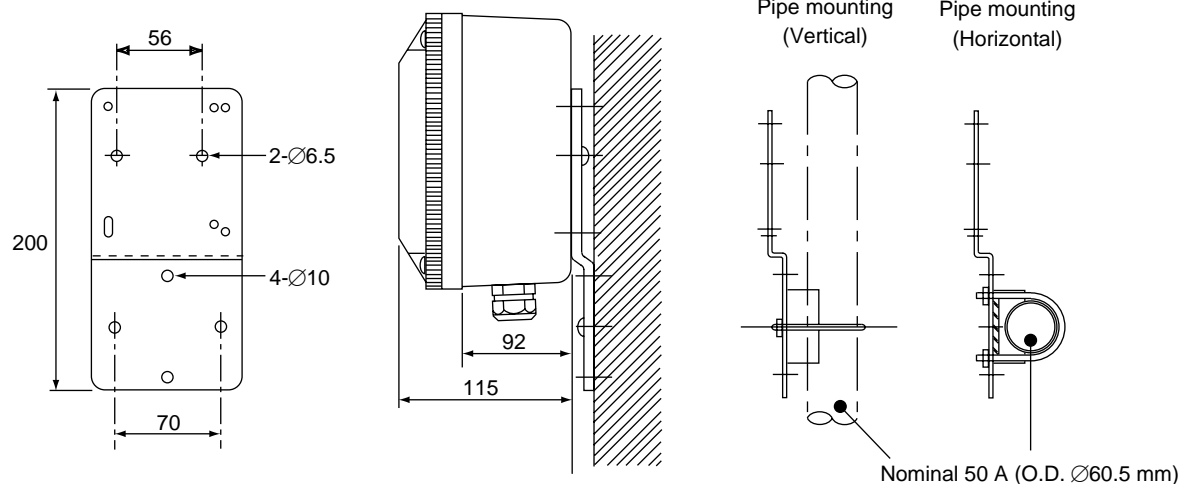

□ Panel Mounting Hardware (Option code : /PM)

Weight : Approx. 0.4kg

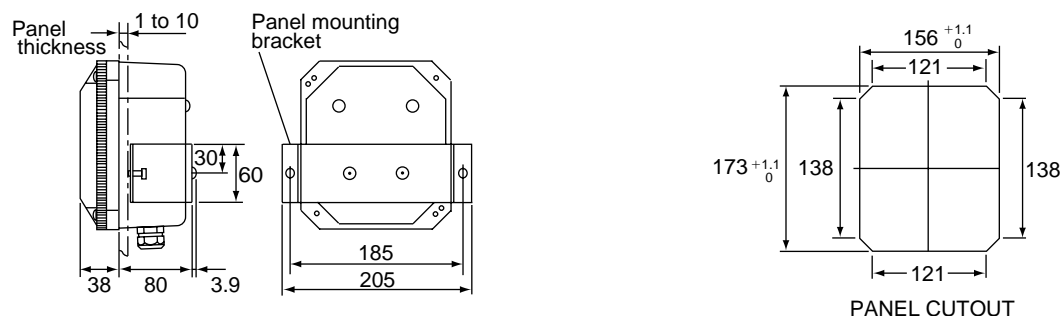

Panel Mounting when using two(2) self-tapping screws

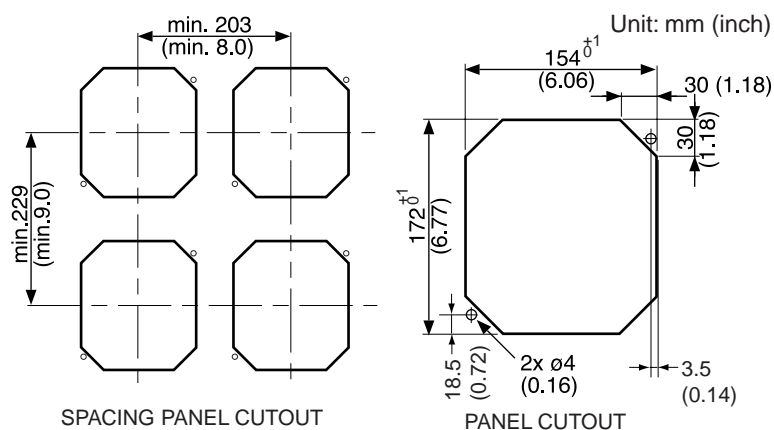

Unless otherwise specified, differences in the dimensions are specified as : General tolerance = ±(Criteria of tolerance class IT18 in JIS B0401 - 1986)/2