

Drawings

GD40□ Gas Density Meter Detector

• Hardware for Plate Mounting

Model GD40□-□/EJAJ1, EJAF2, EJAF3, EJAF4
GD40□/EJAJ1, EJAF2, EJAF3, EJAF4

Unit : mm

Weight: approximately 15 kg (27.8 pounds)

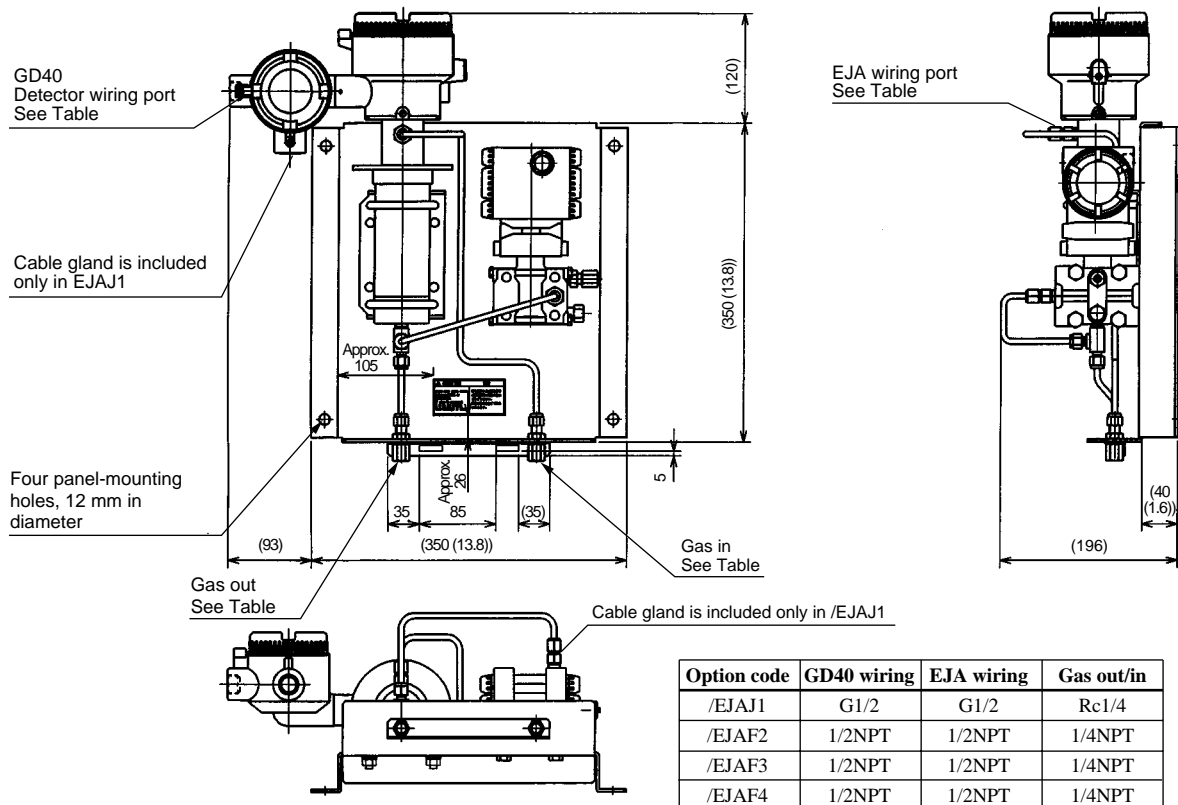

Unless otherwise specified, difference in the dimensions are specified as : General tolerance = ± (Criteria of tolerance class IT18 in JIS B0401-1986) / 2

• Hardware for Pipe Mounting : Model GD 40□-□ or GD 40□

Unit : mm

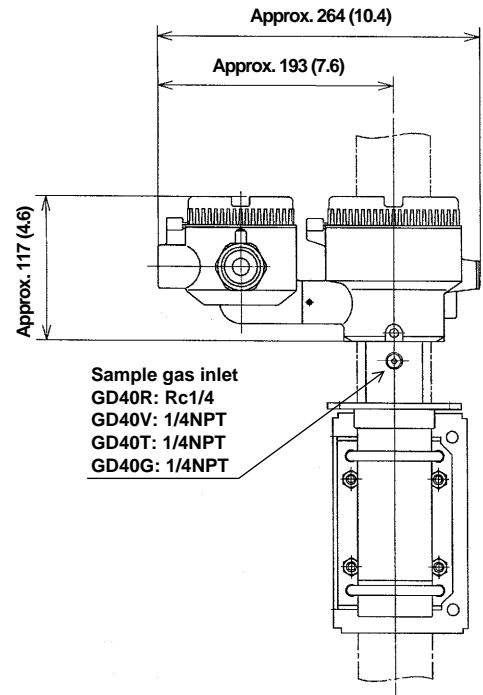
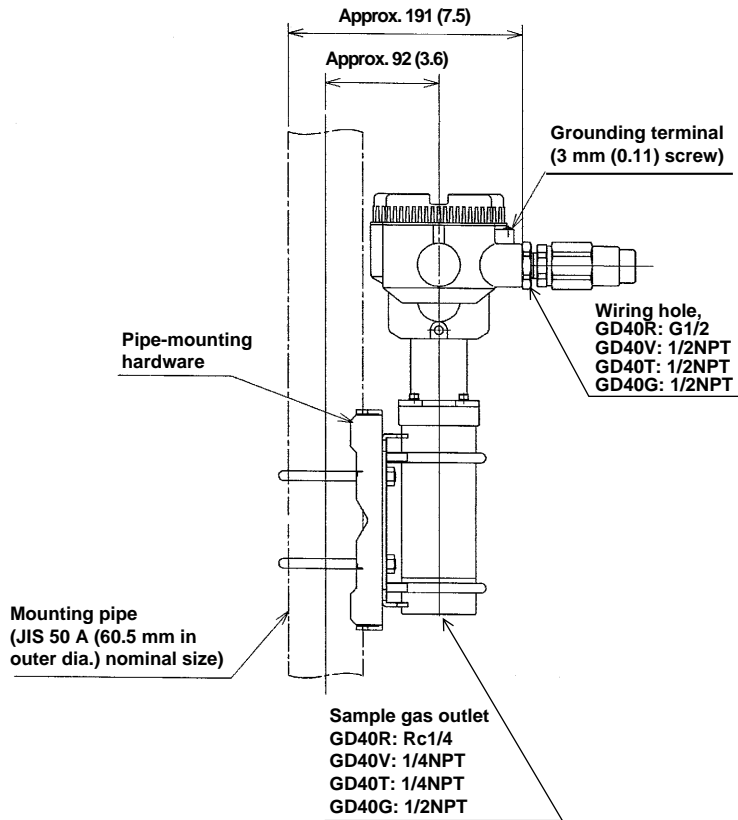

Note: Cable gland is included only in GD40R.

Unless otherwise specified, difference in the dimensions are specified as : General tolerance = \pm (Criteria of tolerance class IT18 in JIS B0401-1986) / 2

SD 11T3E1-03E 2/3

1st Edition : Aug. 1998
2nd Edition : June. 200

Wiring

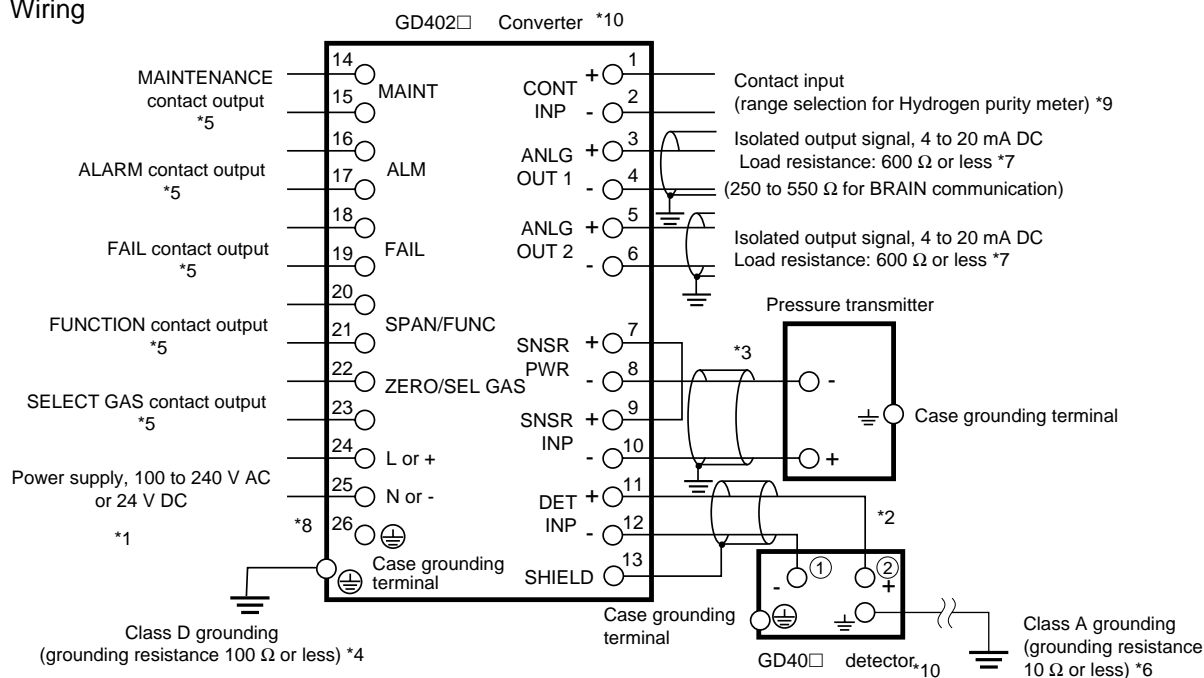

- *1: Power supply
Use a two-conductor cable with an OD of 8 to 12 mm.
- *2: Connection to the detector
 - a. Use a two-conductor shielded cable. In addition, the go-and-return resistance must be 50 W or less (for conductors with a cross sectional area of 1.25 mm² and a length no greater than 1.4 km).
 - b. Be sure to ground the two-conductor shielded cable at either end of the shield. If an unusual phenomenon occurs due to noise, increase the countermeasures against noise. (For example, ground the detector body or use a double-shielded cable. If a double-shielded cable is used, ground shields of each conductor on either side of the cable. Ground the end of the outer shield on the detector side to the case of the detector and connect that end on the converter side to terminal 13.) See the Instruction Manual for more precise instructions on cable installation.
 - c. Terminal 13 is for the detector only.
- *3: Connection to the pressure transmitter
 - a. Use a two-conductor shielded cable with an OD of 8.5 to 11 mm. In addition, the go-and-return resistance must be 50 W or less (for conductors with a cross sectional area of 1.25 mm² and a length no greater than 1.4 km).
 - b. Be sure to ground the two-conductor shielded cable at either end of the shield.
- *4: Be sure to ground the case of the converter.
- *5: The contacts for the contact outputs are all dry contacts whose NO/NC state can be freely set except for the FAIL contact which is an NC contact and cannot be freely set. Their contact rating is 250 V AC, 3 A or 30 V DC, 3 A each.
 - Function contact ; use distinguish between H₂ purity meter and Replacement meter.
 - Select Gas contact ; use distinguish measuring ranges in Replacement meter.
- *6: If the detector is to be installed and used in a hazardous area, be sure to implement class A grounding work (grounding resistance is 10 W or less). In addition, the grounding point of class A grounding must be located in a non-hazardous area.
- *7: Use a two-conductor shielded cable. Be sure to ground the two-conductor shielded cable at either end of the shield.
- *8: Terminal 26 is connected to the case-grounding terminal.
- *9: For hydrogen purity meter, the contact input is used for range selection.
Open: Concentration measurement for air in carbon dioxide
Close: Concentration measurement for hydrogen in carbon dioxide
- *10: GD402V, GD40V; All wiring shall comply Canadian Electrical Code and Local Electrical Codes.
GD402T, GD40T; All wiring shall comply with National Electrical Code and ANSI / NFPA 70 and Local Electrical Codes.

NOTE ; The following cable with an OD size between instruments is used.

instrument	Detector GD40R	Pressure transmitter EJA310	Output signal	Contact input /output
GD402R Explosion-proof	Ø10 to Ø13.5	Ø8.5 to Ø11	Ø8 to Ø16	Ø8 to Ø16
GD402G Non-Explosion-proof	Ø10 to Ø12		Ø6 to Ø12	Ø6 to Ø12

- GD402T, V Converter and GD40R, V Detector is no cable gland included. (The outside diameter of the cable is chosen by cable gland to use.)