

Drawings

2-wire Conductivity Metering system SC202S [Style: S2, S3] Transmitter

EXA SC

Unit : mm

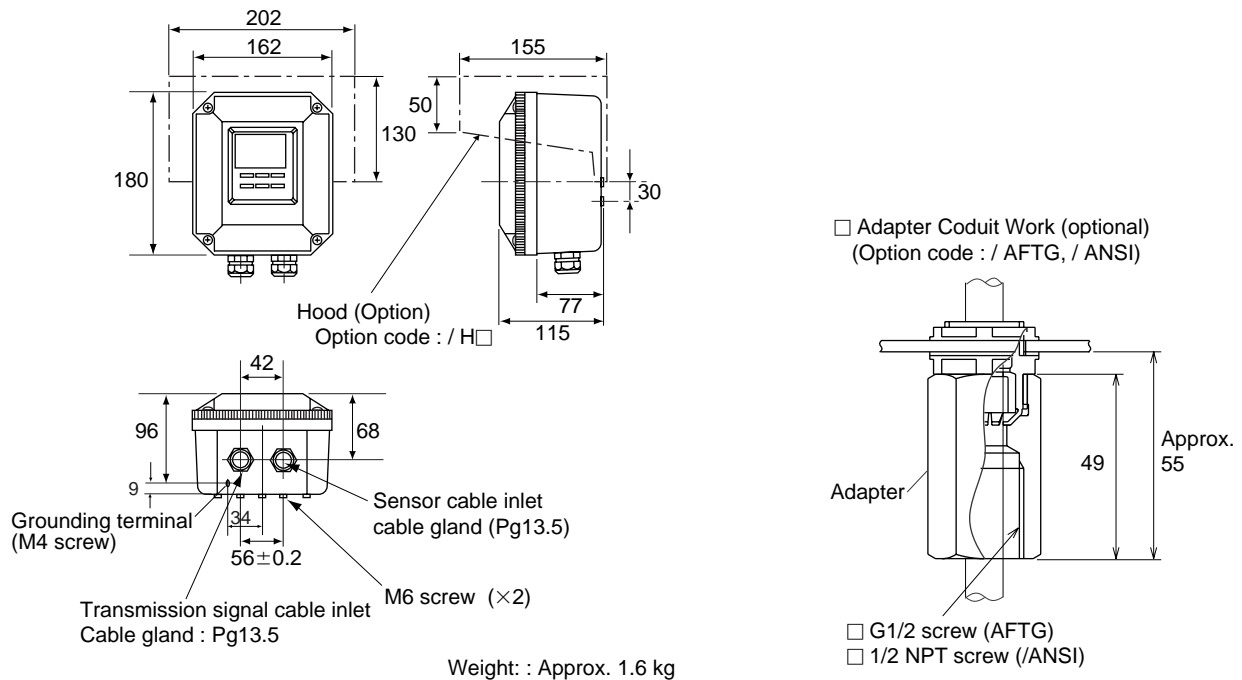

Wiring Diagrams

Example of Explosionproof System

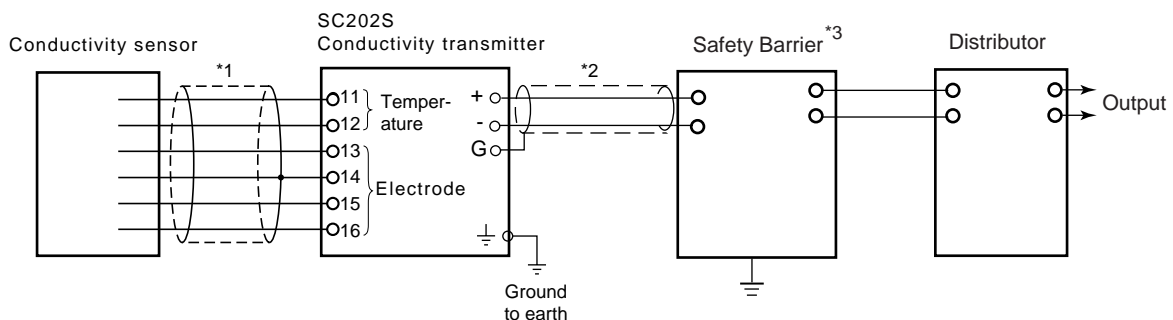

*1: This cable is specified by the additional code of a conductivity sensor, or a sensor cable.

*2: Use two-wire cable with OD (Outside Diameter) of 6 to 12 mm.

*3: For intrinsically safe approval, use the safety barrier certified by the testing laboratories. In case of non-incendive type (SC202S-B, -N, -D), the safety barrier is not necessary.

F007-1.eps

Unless otherwise specified, differences in the dimensions are specified as : General tolerance = \pm (Criteria of tolerance class IT18 in JIS B0401 - 1986)/2

□ Pipe Mounting Hardware (Option code : / U)

Weight : Approx. 0.4kg

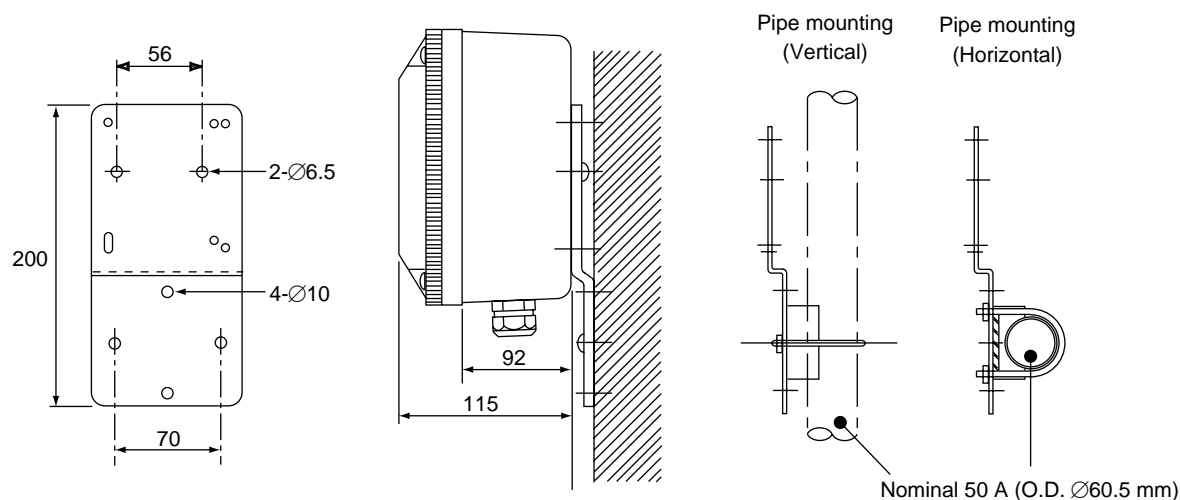

□ Panel Mounting Hardware (Option code : /PM)

Weight : Approx. 0.4kg

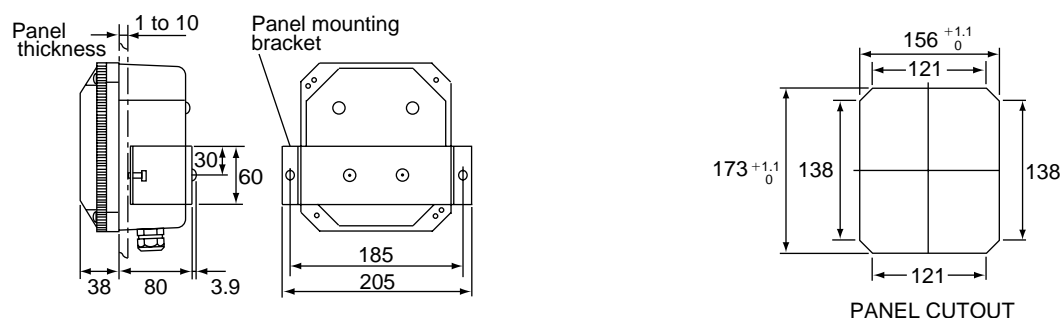

Panel Mounting when using two(2) self-tapping screws

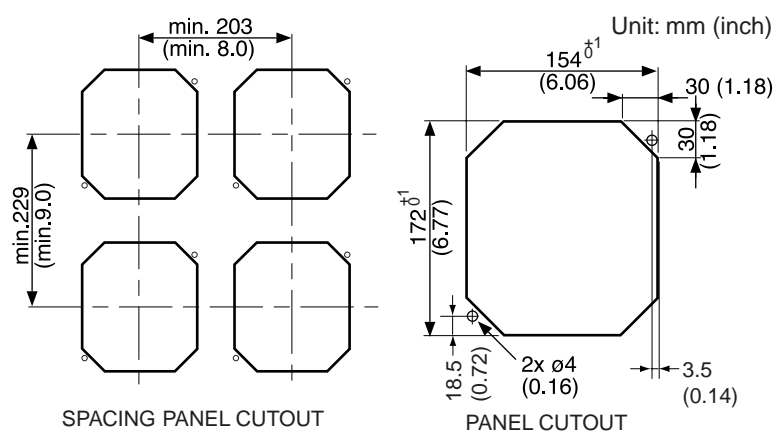

Unless otherwise specified, differences in the dimensions are specified as : General tolerance = \pm (Criteria of tolerance class IT18 in JIS B0401 - 1986)/2