

# General Specifications

## GC1000 Ethernet Analyzer Bus System

GC1000 MarkII

GS 11B06A01-01E

### GENERAL

Process analyzers are typically maintained by maintenance personnel from the front of the analyzer. However, with the implementation of an analyzer bus system, maintenance can now be done entirely by monitoring and operating the analyzers from a remote location. A personal computer can be used as a terminal for controlling the analyzers, enabling the maintenance person to operate the gas chromatograph and field analyzers from a comprehensive computer screen interface instead of the conventional gas chromatograph processor panel and chromatographic recorder.

The analyzer bus system offers the following benefits:

- Comprehensive and centrally located remote maintenance of analyzers.
- Reduction in the cost of wiring (among field analyzer to control room).
- Ease of expansion that is not limited by the physical number of available DCS process inputs.

### FEATURES

- Easy Maintenance of Analyzers  
Status of multiple analyzers can be monitored on a PC connected to the network. Data are continuously stored in a server, allowing traceability of information necessary for maintenance.

Stored data include chromatograms of detector signals as well as measured values and alarms. Even after observation of an alarm or a change in measured value, chromatograms can be checked retrospectively. Other functions include data storage, parameter uploading/downloading, and network monitoring, with regard to the analyzers connected.

- Reduced Wiring Costs  
The analyzer bus system eliminates the need for wiring between the individual field analyzers and the associated devices, such as a DCS or other host computers, and a PC for analyzer maintenance. Ethernet allows hubs and other general networking equipment to be used.
- Network Scalability  
Ethernet facilitates connection to your network, thereby enabling remote monitoring. (To ensure the safety of your network, firewalls or other network security measures should be taken as appropriate.)
- High-Speed Network  
Fast Ethernet supports data transfer rates of 100 Mbps, providing real-time monitoring of not only measured values and alarm information but also chromatograms.
- Optical Communication  
The analyzer is available with either shielded twisted pair wire or optical fiber. The optical fiber can be advantageously used in long distance networks and electrically noisy environments.
- Redundant System for Increased Reliability  
A redundant system is available for connection of analyzers with host computers such as a server and DCS.

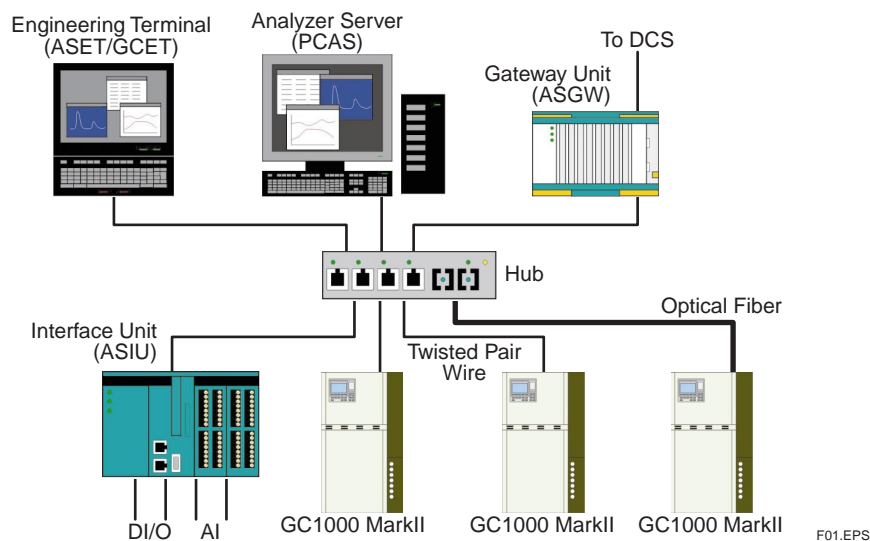

Figure 1 Typical System Configuration

## ■ SYSTEM CONFIGURATION

A typical network configuration of analyzer bus is shown in Figure 1.

The network consists of process gas chromatograph (GC), server, hub, etc.

### (1) Process Gas Chromatograph (GC1000 Mark II)

Analyzers that is installed in the field and connected to Ethernet network.

### (2) Analyzer Server

Controls network and stores the data. It is composed of PC and application software. PC is connected to analyzers with Ethernet network.

### (3) Engineering Terminal

A human machine interface for analyzer control and data view. Its software runs on a PC connected to network.

Two types of software are available for engineering terminal: Analyzer Server Engineering Terminal (ASET) that can handle multiple analyzers via analyzer network and GC Engineering Terminal (GCET) that provides one-to-one communication with analyzer.

### (4) Gateway Unit

Exchanges data with the host systems. It is necessary for redundant network or address mapping.

### (5) Interface Unit

Interfaces field analyzers other than GC with network. Equipped with analog inputs and contact inputs/outputs.

## ■ SPECIFICATIONS

### 1. Network (Ethernet)

Type: IEEE802.3u 100Base-TX, 100Base-FX  
 Protocol: TCP/IP  
 Communication rate: 100 Mbps  
 Cabling: Shielded twisted pair wire or optical fiber  
 Max. number of nodes: 254  
 Max. distance: 100 m (100Base-TX)  
 2 km (100Base-FX)  
 Total distance can be extended using multiple levels of switching hubs\* in cascade connection.

\*Refer to the switching hub.

#### Redundant Network:

Two communication paths are provided. Both are equal and which is used is determined by device engaged in the communication.  
 GC1000 Mark II should have dual channel Ethernet outputs and server PC has two Ethernet ports. Analyzer server, gateway unit, GC1000 Mark II and interface unit can be connected to a redundant network, but engineering terminals cannot.

## 2. Devices

### 2.1 Process Gas Chromatograph

GC1000 Mark II which connects to Ethernet network needs to be equipped to Ethernet communication ports.

Instrument specifications:

Analyzer type and style:  
 GC1000 Mark II Style 6.01 or higher  
 Connection type: Ethernet communication ports of GC1000 Mark II should be specified.  
 Twisted pair: RJ-45 1 or 2 ports  
 Optical fiber: SC 1 or 2 ports  
 Max. number of GC1000 Mark II connected to a network: 240 units  
 Number of analyzer servers one GC1000 MARK II can access: 2 servers

Functions: Ethernet connection allows commands, status detection and data acquisition from analyzer server.

For other functions, refer to General Specifications of the GC1000 Mark II, GS 11B03A03-01E.

### 2.2 Analyzer Server

Realized by analyzer server software (PCAS) installed on PC.

PC specifications

Type: IBM PC compatible desktop computer  
 Hard disk drive: 10 GB or more free space  
 Display: SVGA (1024x768)  
 OS: Windows 2000 SP4, Windows XP Professional Edition SP2  
 Japanese edition/English edition  
 Ethernet port: 1 port (100Base-TX or 100Base-FX) for non-redundant configuration  
 2 ports (100Base-TX or 100Base-FX) for redundant configuration  
 Others: CD drive

PC analyzer Server software (PCAS) specifications

Analyzer bus connection:  
 Max. number of connected analyzers and analyzer bus interface units (FCN): 64 sets

Max. number of PCAS in one network : 14 sets

Automatic data storage:  
 Data of GC1000 Mark II and analyzer bus interface unit are stored on the server PC.

Storage Data	Description	Remarks
Analysis results	Detailed analysis results are stored for one year. Based on this, historical data of concentration and retention time are made.	Storage capacity depends on hardware and settings.
Chromatogram history (1)	Chromatograms for every cycle for the past 2 months.	ditto
Chromatogram history (2)	Every 10 times of chromatograms for one year.	ditto
Alarm history		100 kbyte
Event history		100 kbyte

T01.EPS

Stored data are read with analyzer bus engineering terminal software (ASET).

Network monitoring screen:

Analyzer server communication status is monitored for troubleshooting purpose.

### 2.3 Analyzer Server Engineering Terminal

Realized by engineering terminal software (ASET) installed on PC.

#### PC specifications

Type: IBM PC compatible desktop computer  
 Hard disk drive: 10 GB or more free space  
 Display: SVGA (1024x768)  
 OS: Windows 2000SP4, WindowsXP Professional Edition SP2 Japanese edition/English edition  
 Ethernet port: 1 port (100Base-TX or 100Base-FX)  
 Others: CD drive

#### Analyzer server engineering terminal software (ASET) specifications

Function: ·Display of the status of GC1000 Mark II, Analyzer bus interface unit (FCN) and network.  
 ·Display of the results and alarms stored on the servers (PCAS).  
 ·Operation of GC1000 Mark II and analyzer bus interface unit.

Screen display: a) Overview  
 b) Analyzer Operation  
 c) Analysis Result  
 d) Chromatogram  
 e) Alarm Status  
 f) LCD Emulator (EtherLCD)  
 Max. number of EtherLCD is 4.

Analyzer server connection:  
 Max. number of ASET connected to one PCAS: 4 sets  
 ASET is connectable to PCAS on the same PC.  
 One ASET is activated on one PC.  
 ASET is not activated with GCET on the same PC.

### 2.4 GC Engineering Terminal

Realized by GC engineering terminal software (GCET) installed on PC.

#### PC specifications

Type: IBM PC compatible desktop computer  
 Hard disk drive: 10 GB or more free space  
 Display: SVGA (1024x768)  
 OS: Windows 2000SP4, WindowsXP Professional Edition SP2 Japanese edition/English edition  
 Ethernet port: 1 port (100Base-TX or 100Base-FX)  
 Others: CD drive

#### GC engineering terminal software (GCET) specifications

Function: ·Display of the status of GC1000 Mark II  
 ·Display of the results and alarms stored on the same PC.  
 ·Operation of GC1000 Mark II  
 GCET communicates with one GC1000 Mark II at once.  
 GCET is not activated with ASET on the same PC.

Screen display: a) Analyzer Operation  
 b) Analysis Result  
 c) Chromatogram  
 d) Alarm Status  
 e) LCD Emulator (EtherLCD)

### 2.5 Analyzer Bus Gateway Unit

Established by Yokogawa's FCJ Autonomous Controller and analyzer server gateway unit software (ASGW).

Interfaces with DCS or other host system as a Modbus RTU slave.

#### Instrument specifications

Analyzer bus connection:  
 Max. number of connected GC1000 Mark II and interface units: 31 sets  
 DCS connection  
 Serial connection: Modbus RTU slave, 2 ports available  
 Hardware specifications

Serial communication:  
 Function: transmit and receive data.  
 Type: RS232-C  
 Number of port: 2 ports  
 Protocol: Modbus  
 Transmission rate: 300, 1200, 2400, 4800, 9600, 14400, 19200, 28800, 38400, 57600, 115200 bps  
 Data length: 8 bits  
 Parity bit: selectable  
 Stop bit: 1 bit

#### Compliant standards

EMC standards: CE Mark  
 Standard for hazardous location equipment: Non-Incendive

Refer to the specifications of FCJ.

#### Hardware

Model Name	Item	Remarks
NFJT100-S10x	FCJ	

T02.EPS

#### Software license

License Code	Item	Remarks
NT711AJ-LM03E	FCN/FCJ basic software for single CPU including JAVA	Required for each ASGW
NT8035J-LW11A	Modbus Portfolio	Required for each ASGW

T03.EPS

#### Software media

CR-ROM Code	Item	Remarks
NT203AJ-PC11E	Software media	Loading a license for installation Modification of IP address

T04.EPS

Analyzer server gateway software (ASGW):  
 Data mapping of GC1000 Mark II, interface unit and host system such as DCS for interface with host system.  
 Capable of commanding, detecting status, and reading data as follows.

- (a) Commands for GC1000 Mark II:
- Request of collective analyzer clock setting (all connected analyzers)
  - Request of individual analyzer clock setting (specified analyzers)

GC1000 Mark II through mapping:

- Run command
- Stop command
- Stream sequence assign
- Calibration (validation) command
- Stream (continuous) assign

Interface unit through mapping

- DO on command
- DO off command

(b) Status detection of

GC1000 Mark II and interface unit in common

- In operation
- Communication error
- Write error

GC1000 Mark II

- Analyzer normality/failure
- Change of analyzer alarm status
- Measurement, stop, or maintenance status
- Progress of stream sequence
- Rejection of request of stream (continuous)
- Rejection of request of calibration/validation
- Data update
- Calibration coefficient update
- Data validity
- Each alarm condition
- Concentration alarm of each peak, retention time alarm, variation coefficient alarm, tailing coefficient alarm

Interface unit

- Unit normality/failure
- Main power supply failure, 24 V DC failure, IO module failure
- DI data
- DO data
- AI IOP  
IOP occurs when value exceeds 106.3 % of input range or is below -6.3 %. If IOP occurs, the previous value will be held as AI data.

(c) Data of

GC1000 Mark II

- Stream number
- First peak number
- Number of peak
- Sampling time
- Analysis result
- Retention time
- Calibration coefficient

Interface unit

- AI read data  
(Actual number in 2 words: Range 0.0-1.0)

When multiple requests are received in update period, the last request is executed.

**2.6 Analyzer Bus Interface Unit**

Realized by Yokogawa's FCN Autonomous Controller and analyzer server interface unit software (ASIU).

Function: Read and Write I/O interface data every 200 ms.

Hardware specifications

- Max. number of contact inputs: 16
- Max. number of contact outputs: 16
- Max. number of analog inputs: 16

Specification	Item	Remarks
NFBU200-Sxx	Back board	
NFCP100-S0x	CPU	
NFPW441-1x	Power card	100-120 VAC
NFPW442-1x		220-240 VAC
NFPW444-1x		
NFDV151-P10/B5S00	DI card	32 points, 24 VDC
NFDV551-P10/D5S00	DO card	32 points, 24 VDC
NFDR541-P00/C4S70	Relay output card	16 points, 24-110 VDC /100-240 VAC
NFAI135	AI card	4-20 mA 8 points
NFAI143	AI card	4-20 mA 16 points
NFFCV01	Dummy cover	for I/O card
NFFCV00	Dummy cover	for power card

T05.EPS

Software license

License Code	Item	Remarks
NT711AJ-LS03E	FCN/FCJ basic software for single CPU excluding JAVA	Required for each ASIU
NT8035J-LW11A	Modbus Portfolio	Required for each ASIU

T06.EPS

Software media

CR-ROM Code	Item	Remarks
NT203AJ-PC11E	Software media	Loading a license for installation Modification of IP address

T04.EPS

Analyzer server interface unit software (ASIU)

Capable of commanding, detecting status, and reading data as follows.

- (a) Command
  - DO on/off command
- (b) Status detection
  - Unit normality/failure
  - Main power supply failure, 24 V AC failure, IO module failure
  - DI data
  - DO data
  - AI IOP  
IOP occurs when value exceeds 106.3 % of input range or is below -6.3 %. If IOP occurs, the previous value will be held as AI data.
- (c) Data
  - AI read data  
(Actual number in 2 words: Range 0.0-1.0)

**2.7 Network Components**

(a) Hub

Switching type 100Base hub is recommended.

example; MOXA made P/N:EDS-308-MM-SC (multi mode, wave length 1310 nm 100Base-FX (SC connector) 2 ports, TP (RJ45) 6 ports)  
(Area classification: class 1 Div 2/Zone 2)

**(b) Cable**

**• Optical Fiber Cable**

It is recommended to use optical fiber cable when extending distance, wiring between separate buildings or using the device in electrically noisy environments.

Optical fiber cable does not require an "Electric energy blocking-off circuit" for explosion proof.

The type of optical fiber is the multi mode which core diameter is 50/125 μm or 62.5/125 μm.

GC1000 Mark II has port(s) with 100Base-FX SC connector.

**• Twisted Pair Cable**

GC1000 Mark II has port(s) with RJ-45 connector for twisted pair output.

Use Category 5 or higher of ScTP (Screened twisted pair) or STP cable. CE Mark is declared on the condition with ScTP or STP cable.

Twisted pair cable requires an "Electric energy blocking-off circuit" for explosion proof. Refer to section 2.11, Explosion-proof.

There are two types of pair cables: straight-through or cross-over. Generally, a straight-through cable is used to connect between a node and a hub, a cross-over cable is used to directly connect between nodes.

**(c) Media Converter**

Since gateway interface unit (FCJ) and general PC do not have optical interface. For connection to an optical fiber network, media converter interface is required.

Select the appropriate devices according to the conditions of infrastructures.

example; MOXA made P/N:IMC-101-M-SC  
(multi mode, wave length 1310 nm  
100Base-FX (SC connector) 1 ports,  
TP (RJ45) 1 ports)  
(Area classification: class 1 Div 2/Zone 2)

**2.8 Analyzer Bus Network**

**(a) Redundancy**

In a redundant network, if one of the paths fails, communication line of analyzed data information is switched to the other automatically, minimizing the influence.

Redundant network requires analyzer bus gateway unit (FCJ) and its software (ASGW).

The following licenses and media are required to duplicate server PC.

License Code

Licence Code	Item	Remarks
NT783AJ-LM11A	Redundant network function license for FCN/FCJ OPC Server (media:NT203AJ)	Required for each PC

T07.EPS

Software media

CR-ROM Code	Item	Remarks
NT203AJ-PC11E	media	Available for ASGW or ASIU.

T08.EPS

Communication lines of server PC, gateway unit (FCJ), GC1000 MarkII and interface unit (FCN) are duplicated.

Communication line of engineering terminal PC (ASET or GCET) is not duplicated

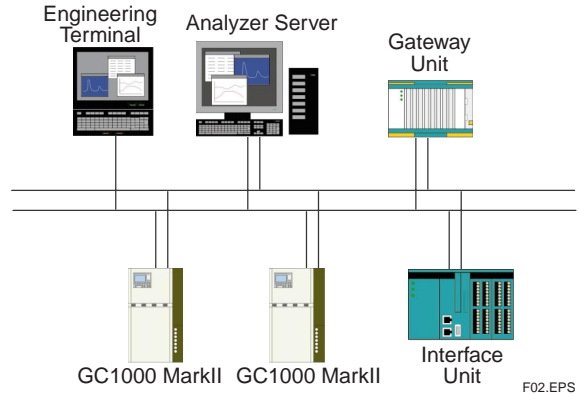

**(b) Restrictions on Total Distances of Network**

According to the 100Base-TX standards, cables of up to 100 meters can be used. Total distance can be extended using multiple levels of switching hubs\* in cascade connections.

\*Refer to the switching hub.

**2.9 Modbus Communication**

Realized by the following methods.

**(a) Connection with analyzer bus gateway unit (FCJ)**

Analyzer server gateway unit can interface as a Modbus RTU slave. Refer to section 2.5, Analyzer Bus Gateway Unit.

**(b) Direct connection to GC1000 Mark II**

Ethernet communication of GC1000 Mark II and analyzer server interface unit support Modbus/TCP client.

**2.10 OPC**

OPC requires analyzer bus gateway unit (FCJ) and OPC server software.

Refer to "FCN/FCJ OPC for Windows" (GS 34P02Q61-01E).

In addition, redundant network function license for FCN/FCJ OPC Server software is required for connecting to the redundant network.

**2.11 Explosion-proof**

The following conditions should be satisfied.

**(a) Process Gas Chromatograph (GC1000 Mark II)**

Refer to the General Specifications of GC1000 Mark II (GS11B03A03-01E)

**(b) Twisted Pair Wiring**

Twisted pair line should be disconnected when the explosion-proof status is not kept at the GC1000 Mark II side.

A 12 V DC output of the analyzer should be used to turn on the power line of the hub. (Figure 3)

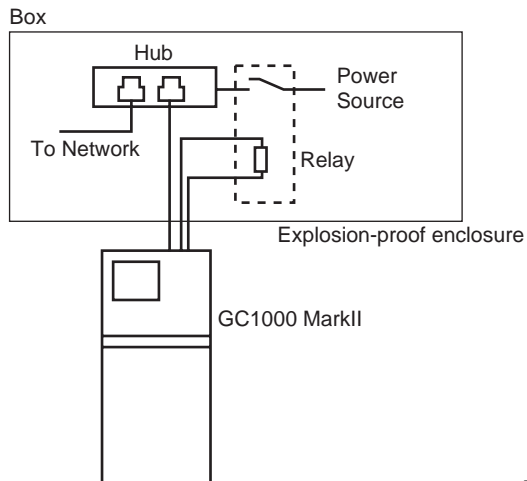

F03.EPS

Figure 3

**(c) Optical Fiber**

Optical fiber cable does not require an "Electric energy blocking-off circuit" for explosion proof.

**(d) Hub**

Non-incendive certified hubs can be installed in Class 1 Division 2 hazardous areas. For compliance with the standard, the hubs must be installed in a cabinet approved by local explosion-proof testing organization. Select the appropriate devices according to the conditions of location and wiring.

**(e) Analyzer Bus Interface Unit**

FCN used as analyzer bus interface unit is approved that the product meets the non-incendive requirements of the FM Standards.

Refer to the General Specifications of FCN/FCJ (GS 34P02Q01E).

**2.12 Security**

PC should be protected against computer viruses. Accesses from external network should be restricted by fire-wall.

## MODEL AND SUFFIX CODES

### 1. Process Gas Chromatograph (GC1000)

Any of the following Suffix Codes should be specified for Ethernet analyzer bus.

Model	Suffix Code	Option Code	Description
GC1000□	-----	-----	Gas chromatograph
...	...	-----	(Note)
Analyzer bus	A	-----	Ethernet twisted pair dual-channel
	B	-----	Ethernet optical fiber dual-channel
	C	-----	Ethernet twisted pair single-channel
	D	-----	Ethernet optical fiber single-channel

T\_GC1000.EPS

Note: For specifications other than GC1000 Mark II analyzer bus's, consult our salesperson or representative.

### 2. PC Analyzer Server Software (PCAS)

Model	Suffix Code	Option Code	Description
PCAS	-----	-----	Software package
Function	-A01	-----	Standard
Language	E	-----	English
	J	-----	Japanese
—	-N	-----	Always -N
—	N	-----	Always N

T\_PCAS.EPS

### 3. Analyzer Server Engineering Terminal Software (ASET)

Model	Suffix Code	Option Code	Description
ASET	-----	-----	Software package
Function	-A01	-----	Standard
Language	E	-----	English
	J	-----	Japanese
—	-N	-----	Always -N
—	N	-----	Always N

T\_ASET.EPS

### 4. GC Engineering Terminal Software (GCET)

Model	Suffix Code	Option Code	Description
GCET	-----	-----	Software package
Function	-A01	-----	Standard
Language	E	-----	English
	J	-----	Japanese
—	-N	-----	Always -N
—	N	-----	Always N

T\_GCET.EPS

### 5. Analyzer Server Gateway software (ASGW)

Model	Suffix Code	Option Code	Description
ASGW	-----	-----	Software package
Function	-A01	-----	Standard
Language	E	-----	English
	J	-----	Japanese
—	-N	-----	Always -N
—	N	-----	Always N

T\_ASGW.EPS

### 6. Analyzer Server Interface Unit Software (ASIU)

Model	Suffix Code	Option Code	Description
ASIU	-----	-----	Software package
Function	-A01	-----	Standard
Language	E	-----	English
	J	-----	Japanese
—	-N	-----	Always -N
—	N	-----	Always N

T\_ASIU.EPS

## ■ TERMINAL ARRANGEMENT

### 1. Process Gas Chromatograph GC1000 Mark II

#### 1.1 Ethernet (Twisted Pair Wiring)

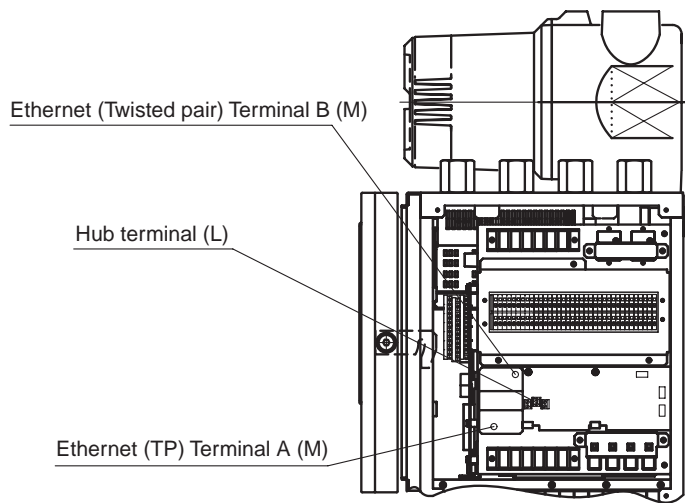

Terminal Number

- Power off signal (A)	3	7	Power off signal (B) -
+ Power off signal (A)	4	8	Power off signal (B) +

F04.EPS

#### 1.2 Ethernet (Optical Fiber Wiring)

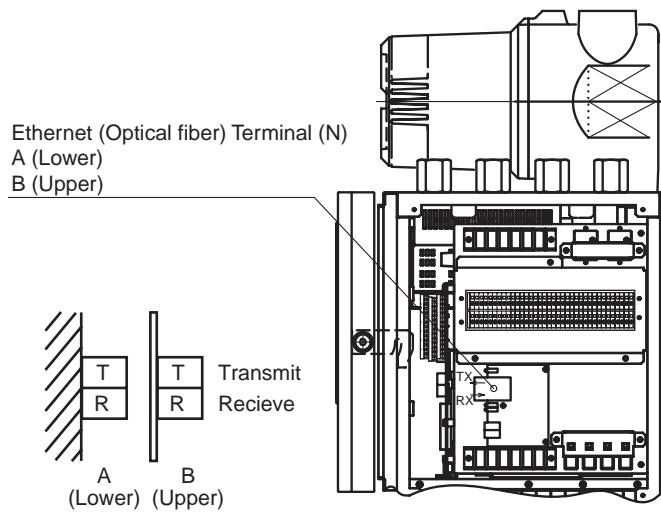

F05.EPS

### 2. Analyzer Bus Gateway Unit

Please refer to the General Specifications, "FCN/FCJ Autonomous Controller Functions" GS 34P02Q01-01E.

### 3. Analyzer Bus Interface Unit

Please refer to the General Specifications, "FCN/FCJ Autonomous Controller Functions" GS 34P02Q01-01E.