

**GC1000 Mark II
Process Gas Chromatograph
Overview**

IM 11B03A03-01E

vigilantplant™

◆ Notice

● Regarding This Manual

1. This Manual should be passed on to the end user.
2. Read this manual carefully and fully understand how to operate this product before you start operation.
3. Yokogawa makes no warranty of any kind with regard to this material, but not limited to, implied warranties of merchantability for particular purpose.
4. All rights reserved. No part of this manual may be reproduced in any form without Yokogawa's written permission.
5. Great effort has been expended to ensure that the descriptions in this manual are correct. Should you, however, come across a questionable area or note an inconsistency, a telephone call or letter to Yokogawa.co.,ltd. noting the questionable area would be highly appreciated.
6. The contents of this manual are subject to change without prior notice.

● Regarding Protection, Safety, and Prohibition Against Unauthorized Modification.

1. For the protection and safe use of the product and the system controlled by it, be sure to follow the instructions on safety described in this manual when handling the product. In addition, if you handle the product in contradiction to these instructions, our company does not guarantee safety.
2. The following safety symbol marks are used on the product concerned or in this Manual :



WARNING

A **WARNING** sign denotes a hazard. It calls attention to procedure, practice, condition or the like, which, if not correctly performed or adhered to, could result in injury or death of personnel.



CAUTION

A **CAUTION** sign denotes a hazard. It calls attention to a procedure, practice, condition or the like, which, if not correctly performed or adhered to, could result in damage to or destruction of part or all of the product.



IMPORTANT:

Indicates that operating the hardware or software in this manner may damage it or lead to system failure.



NOTE:

Draws attention to information essential for understanding the operation and features.



TIP:

Gives information that complements the present topic.



See Also:

Gives the reference locations for further information on the topic.



Protective ground terminal:

In order to provide protection against electrical shock in case of a fault. This symbol indicates that the terminal must be connected to ground prior to operation of equipment.



Function ground terminal:

In order to provide protection against noise. This symbol indicates that the terminal must be connected to ground prior to operation of equipment.



Alternating current



Indicates the power switch state "ON".



Indicates the power switch state "Stand - by".



Indicate the power switch state "OFF".

3. If protection / safety circuits are to be used for the product or the system controlled by it, they should be installed outside of the product.
4. When you replace parts or consumables of the product, use those specified by our company.
5. Do not modify the product.

● **Exemption from Responsibility**

1. Yokogawa Electric Corporation does not make any warranties regarding the product except those mentioned in the WARRANTY that is provided separately.
2. Yokogawa Electric Corporation assumes no liability to any party for any loss or damage, direct or indirect, caused by the use or any unpredictable defect of the product.

● **Regarding Software and set including Software Supplied by YOKOGAWA**

1. Yokogawa makes no other warranties expressed or implied except as provided in its warranty clause for software supplied Yokogawa.
2. Use this software with one specified computer only.
You must purchase another copy of the software for use with each additional computer.
3. Copying this software for purposes other than backup is strictly prohibited.
4. Store the streamer or floppy disk (original medium) in a secure place.
5. Reverse engineering such as the disassembly of software is strictly prohibited.
6. No portion of the software supplied by Yokogawa may be transferred, exchanged, or sublet or leased for use by any third party without prior permission by Yokogawa.

Warning/Caution Labels

- To ensure safety operation of this equipment, warning/caution labels are attached on the equipment as follows. Check these labels for your safety operation.

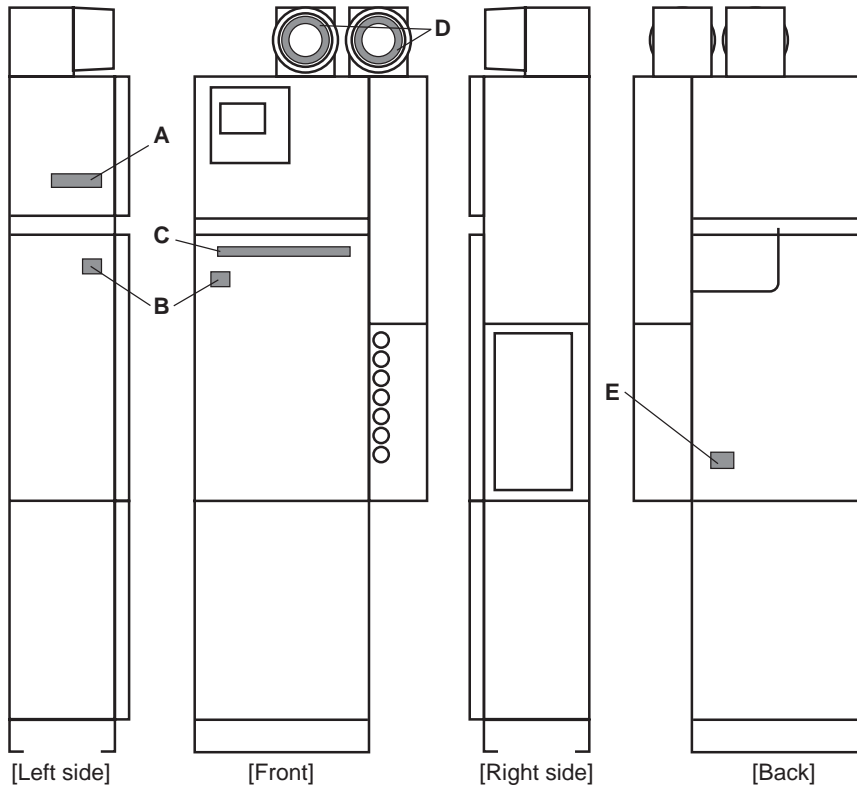

F0001.EPS

A

<p>⚠ WARNING</p> <p>Wait 20 minutes after power disconnection, before opening the cover except the one of isothermal oven with administrators permission.</p> <p>⚠ 警告</p> <p>恒温槽以外のカバーを開ける際は管理者の許可のもとで電源遮断後 20分以上経過してから行って下さい。</p>

B

WARNING	
	Hot surfaces
警告	
	表面が高温です。注意して下さい。

C

<p>CAUTION HIGH TEMPERATURE</p> <p>The inside of the enclosure is high temperature after turning off the power. Don't touch the inside of the enclosure or the components, the protective gas should be supplied for more than one hour after turning off the power.</p>	<p>高温注意</p> <p>通電停止直後は、内部が高温になっています。通電を停止した後 1時間以上保護ガスの供給を保ち、内部および内部の部品に触れないでください。</p>
---------------------------------------------------------------------------------------------------------------------------------------------------------------------------------------------------------------------------------------------------------------------------------	-----------------------------------------------------------------------------------------------

The inside of the enclosure is high temperature after turning off the power. Don't touch the inside of the enclosure or the components, the protective gas should be supplied for more than one hour after turning off the power.

D

E

WARNING	
High Temperature oven exhaust air. Keep hands, electrical cables, gas lines, chart paper and other items safely clear of exhaust stream.	
警告	
排気エアが高温です。注意して下さい。手や電気のケーブル、ガスライン、チャートペーパーなどを排気口に近づけないで下さい。	

F0002.EPS

◆ Introduction

Thank you for purchasing the GC1000 Mark II process gas chromatograph.

This manual describes the technical information on overview of Model GC1000D / GC1000S / GC1000T / GC1000E / GC1000W / GC1000C (Hereafter, it is abbreviated as GC1000 Mark II) Process Gas Chromatograph.

Please lead the following respective documents before installing and using the GC1000 Mark II system.

● Documents Related to the GC1000 Mark II Process Gas Chromatograph

1. Instruction manuals

The product comes with the following instruction manuals.

■ Instruction manuals that do not depend upon the specifications of the product

- (1) Overview (IM 11B03A03-01E)
- (2) Basic Operation and Startup (IM 11B03A03-02E)
- (3) Maintenance and Inspection Manual (IM 11B03A03-04E)
- (4) LCD Panel Operation Manual (IM 11B03A03-05E)
- (5) Alarm Message Manual (IM 11B03A03-06E)
- (6) Password Manual (IM 11B03A03-07E)
and Installation Manual (TI 11B03A03-13E)

■ Instruction manuals that depend upon the specifications of the product

- (1) GCMT Gas Chromatograph Maintenance Terminal Software Package Operation Guide (IM 11B03G03-03E)
- (2) Capture It! Manual (IM 11B3G1-02E)

■ Instruction manuals for related products

- (1) PCAS PC Analyzer Server Software (IM 11B06B01-01E)
- (2) ASET Analyzer Server Engineering Terminal Software (IM 11B06C01-01E)
- (3) GCET GC Engineering Terminal Software (IM 11B06D01-01E)
- (4) ASGW Analyzer Server Gateway Software (IM 11B06E01-01E)
- (5) ASIU Analyzer Server Interface Unit Software (IM 11B06F01-01E)

2. Operation Data

Operation data is supplied with the operation manuals in the delivered package and contains the following required to use the gas chromatographs.

- Process conditions and measurement range
- Instrument specifications and operating conditions
- Standard sample for calibration
- Column system and column
- Miscellaneous data
Chromatogram, base line, repeatability, power supply voltage variation, etc.
- Analyzer flow diagram and installation
- Parts composition table
- General connection diagram
- Sampling system diagram (only if supplied by Yokogawa)

● Is the System Ready?

Before reading this manual, the following preparations must have been completed.

- The system must be unpacked and installed in the correct place.
- The piping for the utility gases such as carrier and calibration gases must be completed, followed by leak checking.
- The wiring for the power supply and others must be completed.

If these have not been completed yet, see the Installation Manual (TI 11B03A03-13E). After completion, return to this manual and do the following:

- If the system power is on, turn off the power.
- Shut off all the gases at the flow control units.

Please read the following respective cautions (General Precautions, Caution of using Explosion-Protection Instruments, on Piping Construction, and on Piping Work) before installing and using the GC1000 system.

● General Precautions



WARNING

- (1) In order to analyze gases, process gas chromatographs use a sample of the process gas and utility gases.

Since these gases are typically combustible, combustion-sustaining, toxic, odorous, resolvable, polymerizing, or corrosive, refer to the “Safety Information” in our approval drawings and others to ensure safety thoroughly before using these analyzers.

- (2) Up to two protection systems, each of which weighs approximately 10 kg, are installed on top of the GC1000. Therefore, the center of gravity is higher than the center of the analyzer body.

Take great care when carrying and installing (piping- wiring) the GC1000. The GC1000 must be carried and installed very carefully (including piping and wiring) by more than one person (at least four people are recommended).

- (3) **Since the GC1000 are precision instruments, take care when handling not to jolt or knock them.**

- (4) **Use the GC1000 within the range of your purchase specifications.**

Yokogawa assumes no responsibility for problems resulting from use by the customer outside the purchase specifications.

If the GC1000 need to be modified or repaired, please contact your nearest Yokogawa representative. Yokogawa assumes no responsibility for results where the customer or any third party has attempted to modify or repair these products.

- (5) When touching LCD Panel switches

When touching LCD Panel switches, first, discharge Electro Static Charge of the body.

Then, touch the LCD Panel switches. If not, LCD display may be changed by Electro Static Discharge.



IMPORTANT:

- (1) Read the attached instruction manual before operating the GC1000
- (2) The instruments must be installed and operated according to the installation manual, instruction manual, approval drawings, and operation data.

● CAUTIONS OF USING EXPLOSION-PROTECTION INSTRUMENTS

The GC1000 Process Gas Chromatographs are designed to protect against explosion. When these analyzers are used in a hazardous area, observe the following precautions.

Since the applicable standard differs depending on the specifications of the analyzer to be used, check the specifications of your analyzer.

(1) Kinds of explosion protection

To assure explosion protection, the GC1000 Process Gas Chromatographs have a pressurized and flameproof construction, or type X purging and explosionproof construction meeting the following standards :

<GC1000D / GC1000S>

- JIS Expd IIB + H2 T1 (programmed-temperature oven 320°C max., isothermal oven 225°C max., liquid-sample valve 250°C max.)
- JIS Expd IIB + H2 T2 (programmed-temperature oven 225°C max., isothermal oven 225°C max., liquid-sample valve 225°C max.)
- JIS Expd IIB + H2 T3 (programmed-temperature oven 145°C max., isothermal oven 145°C max., liquid-sample valve 145°C max.)
- JIS Expd IIB + H2 T4 (programmed-temperature oven 95°C max., isothermal oven 95°C max., liquid-sample valve 95°C max.)

<GC1000W / GC1000C>

CENELEC (ATEX directive) certified : Group II Category 2G

- EEx pd II B +H2 T1 (programmed-temperature oven 320°C max, isothermal oven 225°C max., liquid-sample valve 250°C max.)
- EEx pd II B +H2 T2 (programmed-temperature oven 225°C max, isothermal oven 225°C max., liquid-sample valve 225°C max.)
- EEx pd II B +H2 T3 (programmed-temperature oven 145°C max, isothermal oven 145°C max., liquid-sample valve 145°C max.)
- EEx pd II B +H2 T4 (programmed-temperature oven 95°C max, isothermal oven 95°C max., liquid-sample valve 95°C max.)

<GC1000T / GC1000E>

FM Type X purging and Explosionproof for CLI, DIV1, GPS B, C & D, NEMA3R.

Type Y purging and Type X purging for CLI, DIV1, GPS.B, C & D, NEMA3R.

- T1 (programmed-temperature oven 320°C max., isothermal oven 225°C max., liquid-sample valve 250°C max.)
- T2 (programmed-temperature oven 225°C max., isothermal oven 225°C max., liquid-sample valve 225°C max.)
- T3 (programmed-temperature oven 145°C max., isothermal oven 145°C max., liquid-sample valve 145°C max.)
- T4 (programmed-temperature oven 95°C max., isothermal oven 95°C max., liquid-sample valve 95°C max.)

- CSA Type X purging and Explosionproof for CLI, DIV1, GPS B, C & D, NEMA3R.
Type Y purging and Type X purging for CLI, DIV1, GPS.B, C & D, NEMA3R.
- T1 (programmed-temperature oven 320°C max., isothermal oven 225°C max., liquid-sample valve 250°C max.)
 - T2 (programmed-temperature oven 225°C max., isothermal oven 225°C max., liquid-sample valve 225°C max.)
 - T3 (programmed-temperature oven 145°C max., isothermal oven 145°C max., liquid-sample valve 145°C max.)
 - T4 (programmed-temperature oven 95°C max., isothermal oven 95°C max., liquid-sample valve 95°C max.)

(2) Precautions for Explosionproof section (The analyzer with optional code "FM/CSA Type Y purging" does not have the explosionproof section.)

When handling the screws on the cover of the Protection system, note the following to avoid damaging the screws since they cannot be repaired.

- | |
|------------------------------------------------------------------------------------------------------------------------------------------------------------------------------------------------------------------------------------------------------------------------------------------------------------------------------------------------------------------------------------------------------------------------------------------------------------------------------------------------------|
| <ol style="list-style-type: none">(1) The enclosure is pressurized. Before removing the cover, reduce the internal pressure by loosening the sealing plug for wiring on the enclosure or relevant means.(2) When removing the cover, prevent any dirt or foreign matter from contaminating the screw part.(3) When installing the cover, tighten the screws by hand ; never use tools.(4) Since the screws are coated with MOLYKOTE, do not lubricate them. |
|------------------------------------------------------------------------------------------------------------------------------------------------------------------------------------------------------------------------------------------------------------------------------------------------------------------------------------------------------------------------------------------------------------------------------------------------------------------------------------------------------|

(3) Precautions when using hydrogen gas

When using hydrogen gas as the carrier gas, the FID or FPD combustion gas, to ensure safety, install the analyzer in a location equipped with a ventilator or where there is sufficient ventilation. Make sure there are no gas leaks from the pipe joints and inspect for leaks.

(4) Installation site and environment

The analyzer specifications allow it to be used in hazardous areas as defined by Zone1 IIB + H₂T₁, T₂, T₃, T₄ (JIS / CENELEC) or DIV1, GPS B, C & D, T1, T2, T3, T4 (FM / CSA). However, never install the analyzer in an area where the density of explosive gas persists for a long time.

(5) Wiring works

Model GC1000D / GC1000S, analyzer obtains explosion proof authorization by the complete set including metal fittings of the attachment.

When performing wiring, always use the attached sealing fittings and flameproof packing adapter.

(6) Maintenance and inspection

During usual maintenance and inspection, it is not necessary to check the explosion-protected section.

Before opening the door of the explosion-protected section for maintenance and inspection, be sure to turn off the power. After completing maintenance and checks, close the door completely then turn on the power after checking that the specified explosion protection performance is guaranteed. The parts to be checked are described in the Maintenance and Inspection Manual (IM 11B03A03 - 04E).

If any of the following damage occurs, contact a Yokogawa sales representative or the Yokogawa sales division

- (1) If the screws securing the Protection System (explosionproof construction) are damaged
- (2) If the exterior or light transmission section of the enclosures is damaged
- (3) If packings are cracked or conspicuously deformed

(7) Override function (The analyzer with optional code "FM/CSA Type Y purging" does not have this function.)



WARNING

- When the override function is used, Analyzer becomes an ignition source and the high temperature and the high voltage part will be exposed.
 - Please confirm that in the ambient atmosphere, the concentration of explosive gases is less than the allowable limit, by using a gas detector.
-

To return to the normal operation, turn off "the override switch" and then close the door as it was before turning on power.

In this analyzer, if the pressure of the pressurized / type X purged enclosure system (oven, electronic section) drops while the power is on, the pressurized explosion protection section is activated to stop power supply. Therefore, in case of opening the door of the oven or of the electronic section inadvertently, for maintenance, while the power is on, the protection system is activated to cut off the power.

The "override function" intensively releases this function of protection system.

The override switch is installed in section.

(8) Replacing parts

Always use parts specified by Yokogawa when replacing parts, for replacement, refer to the Maintenance and Inspection Manual (IM 11B03A03 - 04E).

(9) Operation

WARNING

<CENELEC>

- * Only trained persons may use this instrument in a hazardous location.
- * Do not open when energized.

<FM>

For type X purging:

- * This equipment contains components that operate at high temperature. The equipment shall be deenergized for 60 minutes to permit those components to cool before the enclosure is opened unless the area is demonstrated to be nonhazardous at the time.
- * Enclosure shall not be opened unless the area is known to be nonhazardous, or unless all devices within have been de-energized.
- * Power shall not be restored after enclosure has been opened until enclosure has been purged for 12 minutes. (When the internal pressure is restored, the system automatically purges over the 12 minutes, then turns on the power again.)

For explosionproof enclosure:

- * Seal all conduits within 18 inches
- * Open circuit before removing cover.

For type Y purging:

- * Enclosure shall not be opened unless the area is known to be non-hazardous, or unless all devices within have been de-energized. Power shall not be restored after enclosure has been opened until enclosure has been purged for 12 minutes at specified pressure indicated by the pressure gauge labeled "EL.BOX" in the pressure and flow control section.
- * Alarm shall be provided and connected to alarm contact output.
 - (a) The alarm shall generate a visual or audible signal that attracts attention
 - (b) The alarm shall be located at constantly attended location.
 - (c) Electrical alarms shall be approved for the location in which they are installed.

<CSA>

For type X purging:

- * This equipment contains components that operate at high temperature. The equipment shall be deenergized for 60 minutes to permit those components to cool before the enclosure is opened unless the area is demonstrated to be nonhazardous at the time.
- * Enclosure shall not be opened unless the area is known to be non-hazardous, or unless all devices within the enclosure have been de-energized. Power must not be restored after enclosure has been opened until enclosure has been purged for 12 minutes at a flow rate of 0.05m³/min.
- * Power will automatically be removed when purge pressure falls below 40 mm (1.6 in) of water column.

For explosionproof enclosure:

- * A seal shall be installed within 50 cm of the enclosure.
- * Open circuit before removing cover.

For type Y purging:

- * Enclosure shall not be opened unless the area is known to be non-hazardous, or unless all devices within the enclosure have been de-energized. Power must not be restored after enclosure has been opened until enclosure has been purged for 12 minutes at a flow rate of 0.05m³/minute min.
 - * Remove power below 40mm (1.6in) of water column.
-

Take care not to generate mechanical spark when accessing to the instrument and peripheral devices in hazardous locations.

Do not press prick the keyboard of LCD panel (operation and display section) using such as knives and sticks.

(10) Maintenance and Repair

The instrument modification or parts replacement by other than authorized representative of Yokogawa Electric Corporation is prohibited and will void the approval of Factory Mutual Research Corporation and CSA certification and CENELEC certification .

● Precautions Against Electrostatic Problems

The GC1000 system uses numerous IC components. When handling cards with IC components mounted on them for maintenance or setting changes, take full precautions against electrostatic problems.

These precautions are summarized below.

- (a) When storing or carrying cards, enclose them in a conductive bag or antistatic bag. (Cards as shipped by Yokogawa are enclosed in a conductive bag or antistatic bag labeled with cautions against electrostatic problems.)
- (b) Whenever mounting or demounting cards into or from a product, wear a wrist strap grounded via a 1 MΩ resistance. Connect the wrist strap to any ground terminal near the ground wire or to any unpainted part of the grounded frame.

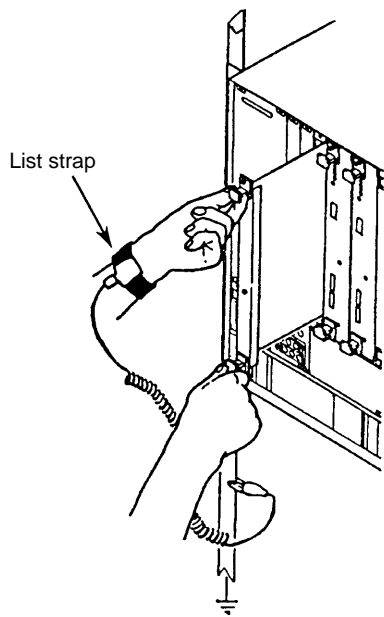

Using a wrist strap and conductive sheet

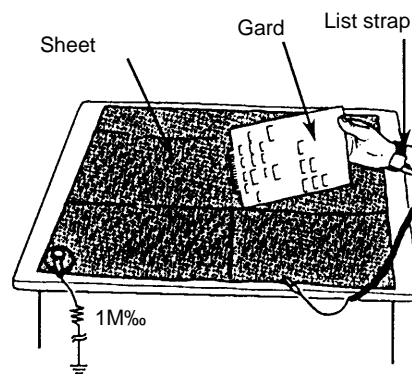

Using a Conductive Sheet

F0003.EPS

- (c) When servicing cards on the bench, place them on a conductive sheet grounded via a 1 MΩ resistance, wearing a wrist strap as in (2) above. Keep easily-chargeable plastic materials away from the bench.
- (d) Never touch components mounted on the cards, the pattern side, connectors, pin components, etc. with bare hands, unless using a wrist strap and a conductive sheet.
- (e) Wrist straps and conductive sheets are available from Yokogawa Engineering Service (YSV).

GC1000 Mark II Process Gas Chromatograph Overview

IM 11B03A03-01E 3rd Edition

CONTENTS

◆	Notice	i
◆	Warning/Caution Labels	iii
◆	Introduction	iv
1.	Principle of Gas Chromatograph	1-1
1.1	Sampling Mechanism	1-1
1.2	Component Separation Using Column	1-2
1.3	Detector	1-3
2.	Terminology	2-1
2.1	Operation Terminology	2-1
2.2	Instrument Terminology	2-2
3.	System Configuration	3-1
3.1	Type and Appearance	3-1
3.2	Components and Their Functions	3-2
3.2.1.	Protection System	3-2
3.2.2	Electronic Section	3-2
3.2.3	Pressure and Flow Control Section	3-2
3.2.4	Isothermal Oven	3-2
3.2.5	Programmed-temperature Oven	3-3
3.2.6	Analyzer Base Sampling Section	3-3
3.3	Block Diagram	3-4
3.4	Internal Piping System Diagram	3-7
3.5	External Input and Output Signals	3-12
4.	Outline of Software	4-1
4.1	Status and Operation Mode	4-1
4.1.1	Process	4-2
4.1.2	Manual	4-5
4.1.3	Lab	4-5
4.2	Stream	4-6
4.3	Method	4-7
4.4	Description of Actions	4-9
4.4.1	Actions of Stream Sequence	4-10
4.4.2	Actions of Stream (Continuous)	4-11
4.4.3	Actions of Stream (1 cycle)	4-13

4.4.4	Actions of Calibration	4-14
4.4.5	Actions of Validation	4-17
4.5	Computation and Processing	4-20
4.5.1	Peak Processing	4-20
4.5.2	Deviation processing	4-20
4.5.3	Additional processing	4-20
4.5.4	Signal Processing	4-21
4.6	Alarm Processing	4-22
5.	Actions of External Input and Output Signals	5-1
5.1	Analog Hold Output	5-1
5.1.1	When Actual Stream is Specified for Stream Number (without Stream Identification Signal)	5-2
5.1.2	When Actual Stream is Specified for Stream Number (with Stream Identification Signal)	5-3
5.1.3	When "99" is Specified for Stream Number (with Stream Identification Signal)	5-4
5.2	Contact Output	5-5
5.2.1	Stream Sequence	5-5
5.2.2	Stream	5-6
5.2.3	Operation Mode	5-6
5.2.4	Alarm	5-6
5.2.5	Timing	5-6
5.3	Contact Input	5-7
5.4	Communication Input and Output	5-8
5.4.1	GC6 Type Output Data Format (Fixed to 45 Characters)	5-8
5.4.2	GC6 Type Input Data Format	5-9
5.4.3	GC8/GC1000 Type Output Data Format (Fixed to 45 Characters)	5-11
5.4.4	GC8/GC1000 Type Input Data Format	5-12
5.4.5	MODBUS Communication Data Specification	5-14
◆	Revision Record	i

1. Principle of Gas Chromatograph

A gas chromatograph is an analyzer which first sends a fixed volume of the sampled multi-component gas mixture to a column, separates it in the column, then measures the concentrations of the components with a detector. The process gas chromatograph analyzes intermittently, allowing periodic analysis in a specified sequence, thus automatic sampling is possible.

This chapter explains the measurement principle of the GC1000 Process Gas Chromatographs.

1.1 Sampling Mechanism

The process gas chromatograph consists of a sampling mechanism, a column and a detector.

Sampling is carried out by switching a sampling valve. When separating components or detecting concentrations, the sampling valve is set to allow the gas (liquid) to be measured to flow through the sample column. When sampling, the sampling valve leads the gas (liquid) to be measured to a column on a carrier gas. (See Figure 1.1)

There are two important points regarding sampling: a regular volume is sampled since repeated sampling is required; and samples are taken quickly and securely. The volume is fixed by measuring a specific gas (liquid) of controlled temperature and pressure using a sample measurement tube. Samples are taken quickly and securely by ensuring that the gas to be measured always flows without interrupt.

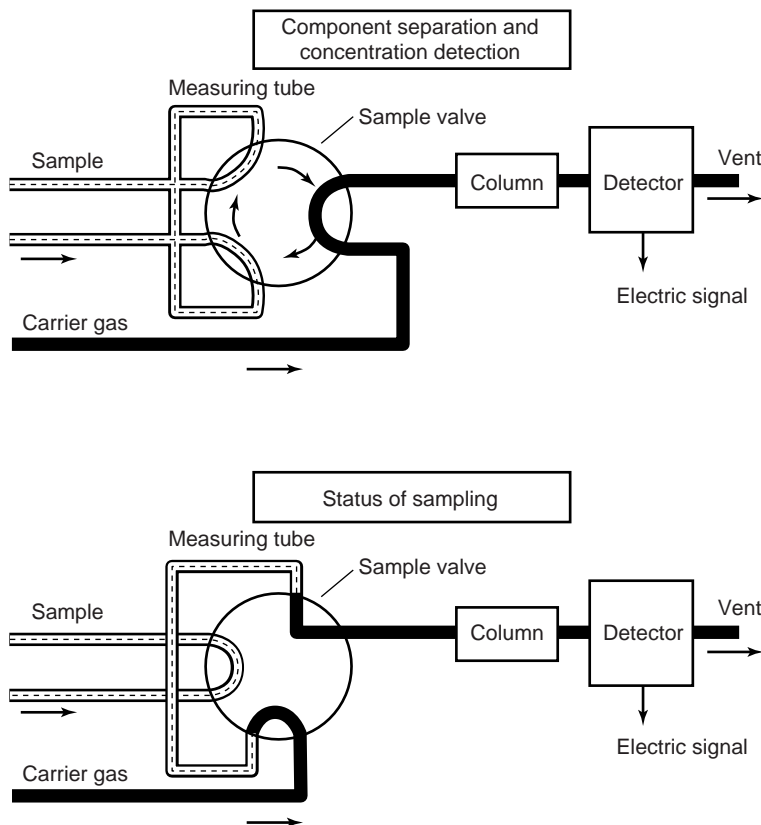

F0101.EPS

Figure 1.1 Basic Configuration of Gas Chromatograph

1.2 Component Separation Using Column

Three types of columns are available for the GC1000 Process Gas Chromatographs: the packed column, the mega-bore column and the capillary column.

The packed column consists of a stainless pipe, 2 mm in diameter and 0.2 to 2.0 m in length and filled with a bulking agent called a stationary phase.

The mega-bore and capillary columns, of approximate diameter 0.5 mm and 0.3 mm respectively, are coated inside a certain phase called a stationary phase.

The components in the multi-component gas mixture sample with carrier gas, which called mobil phase move through the column, repeatedly absorbing the stationary phase and dissolving from the stationary phase at a certain cyclic rate conforming to a fixed partition coefficient * that is unique to each component.

Since the transfer rates differ depending on the partition coefficient, a multi-component gas mixture gradually separates into discrete components and is separated in the order of the transfer rates.

* Partition coefficient : The concentration ratio of the components, calculated by dividing the component concentration which is in equilibrium in the stationary phase by the concentration which is in equilibrium in the mobile phase.

Figure 1.2 shows a diagram of how the multi-component gas mixture is led to a column and separated into its discrete components over time.

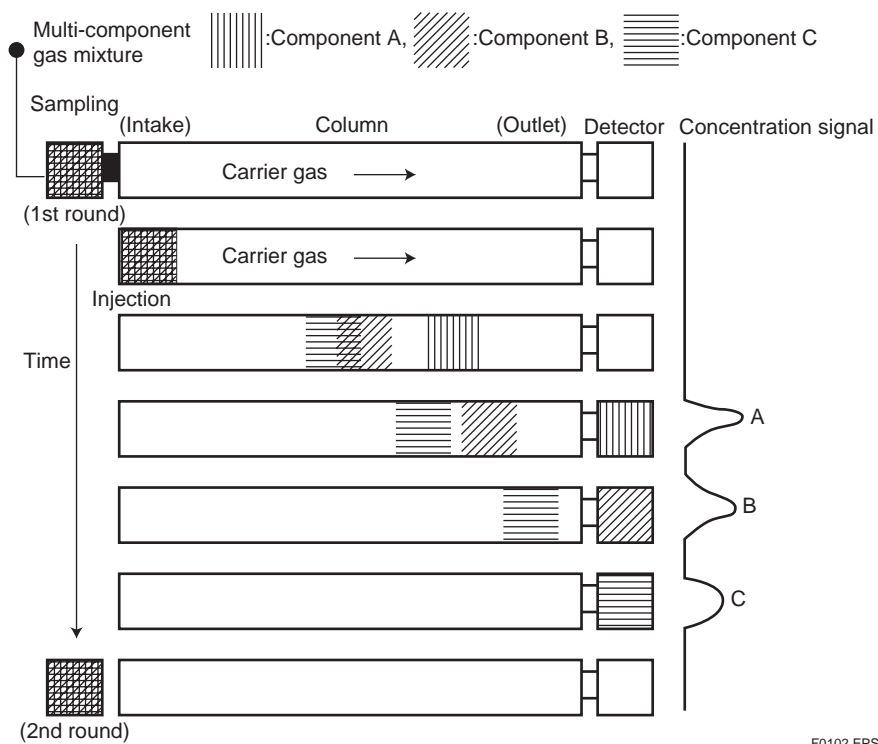

Figure 1.2 Separating Components Using a Column

F0102.EPS

1.3 Detector

The components separated in the column are led to the detector where the concentration of each component is measured.

The GC1000 Process Gas Chromatographs can be fitted with thermal conductivity detectors (TCD), flame ionization detectors (FID) or flame photometric detectors (FPD). The thermal conductivity detector can measure almost all non-corrosive components but sensitivity is relatively low. On the other hand, the hydrogen flame ionization detector can measure hydrocarbon and the flame photometric detector can measure sulfur compounds, respectively with high sensitivity.

(1) Thermal Conductivity Detector (TCD)

The TCD utilizes the difference in the thermal conductivity between the measured gas and the carrier gas and detects the unbalanced voltage produced in a bridge circuit as a measure of concentration.

Figure 1.3 shows the fundamental principle of the TCD. As shown, there are two streams, each having two filaments. One stream passes the carrier gas only and the other, connected to the column outlet, allows the measured gas to pass during analysis. The filaments in the two streams form a bridge circuit such that the filament in one stream is adjacent to the filament in the other stream. The unbalanced voltage in the bridge is proportional to the concentration of the measured gas (liquid) component.

The TCD is frequently used to measure the component concentration of the measured gas (liquid).

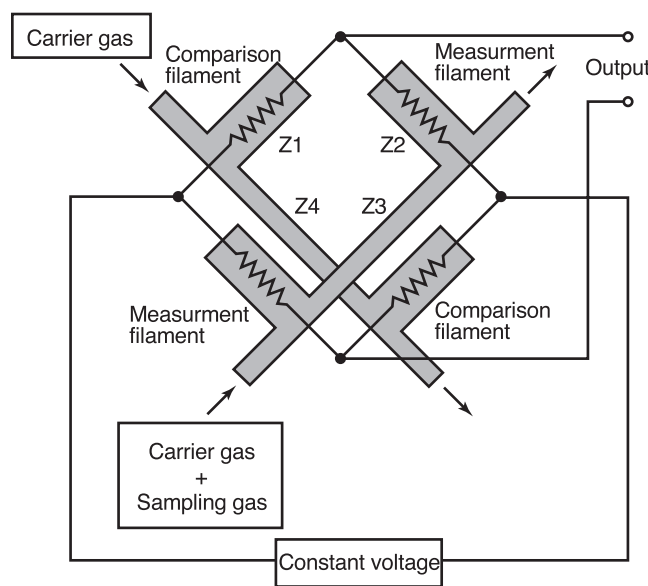

F0103.EPS

Figure 1.3 Fundamental Principle of Thermal Conductivity Detector

(2)Flame Ionization Detector (FID)

The FID utilizes the phenomenon that carbon molecules in the measured component (hydrocarbon) are ionized in a hot hydrogen flame. That is, it detects the ionization current which flows between electrodes to which a high voltage is applied. The ionization current is proportional to the concentration of the measured component.

The FID is used to measure the component concentration of gases containing low concentrations of hydrocarbons.

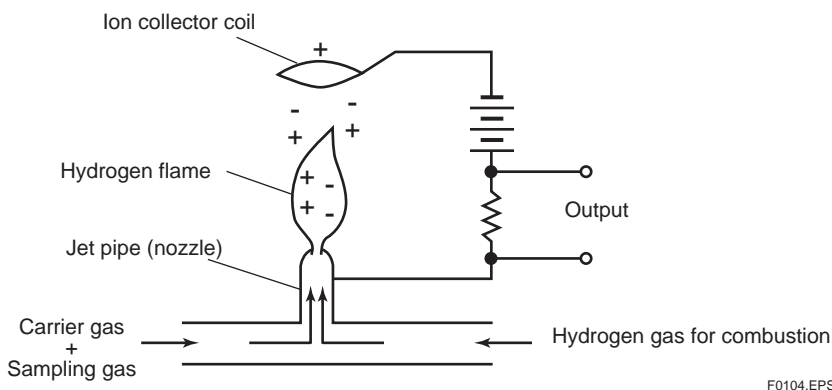

Figure 1.4 Fundamental Principle of Flame Ionization Detector

(3)Flame Photometric Detector (FPD)

Figure 1.5 shows the structure of the FPD. As the sample gas containing a sulfur component is led into the excess hydrogen flame, the component containing the sulfur atoms is excited. The FPD detects the luminous intensity of the light emitted when this excited component return to its base state using multiplier phototube and converts it to a voltage. This voltage represents the concentration of the sulfur component in the measured gas.

The FPD can measure on the sulfur component with a high sensitivity of 1 ppm.

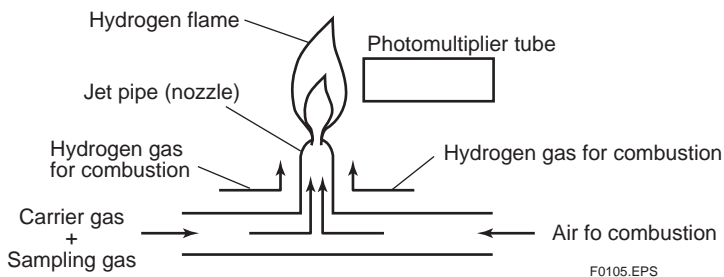

Figure 1.5 Basic Configuration of Flame Photometric Detector

2. Terminology

2.1 Operation Terminology

Term	Description	Notes
Remote Mode	Status accessible without password, LCD/key: used only for reference GCMT: connectable	
Local Mode	Status accessible by entering password LCD/key: used for changing settings	
Status		
Process	Normal measurement and calibration	
Manual	Manual operation	
Lab	Measurement with automatic peak detection, like a lab GC	
Operation Mode		
Run	Mode in which measurement is running	
Pause	Mode in which measurement pauses	
Stop	Mode in which measurement stops	
Measurement Status		
Stream Sequence	Continuously measures streams in order specified in Stream Sequence	
Stream (continuous)	Continuously measures the specified stream	
Stream (1 cycle)	Measures the specified stream once	
Calibration	Performs calibration of the specified number	
Validation	Performs validation of the specified number	
Method	Configures action timing of various valves and other parameters	
Analysis Cycle	Time from start (0 second) to stop of analysis	
Warming Up Time	Time for displacement in sample streams	
Peak Detection Stop Time	Time to stop peak detection of chromatogram compulsorily	
Pause Time	Time for measurement pause	
Purging	Displacement of the gas in the pressurized/Type X purged enclosures with a protection gas	

T0201.EPS

2.2 Instrument Terminology

Term	Explanation	Notes
TCD	A thermal conductivity detector	
FID	A flame ionization detector	
FPD	A flame photometric detector	
LSV	A liquid sampling valve	
Restrictor	A variable resistor	
Methane converter	A methane reaction system : Methanizer	
Sampling valve	A valve for inputting samples	
Back-flush valve	A switching valve for back flush	
Column switching valve	A valve for switching between columns	
Atmospheric-pressure balancing valve	A balancing valve for sampling gases	
Protection gas	Air	
Flame arrester	A device for protecting against "flame runaway"	
Splitter	A flow splitter	
Pressurized enclosure	An enclosure whose internal pressure is kept high with protection gas	
Temperature protection circuit	A circuit for turning off the heater to prevent overheating	
Protection device	A device for detecting a pressure drop in the analyzer to shut down the power supply	
EPC	Electric pressure controller	

T0202.EPS

3. System Configuration

3.1 Type and Appearance

The GC1000 Process Gas Chromatographs consist of (A) a protection system, (B) an electronic section, (C) a pressure and flow control section, (D) an isothermal oven, (E) a programmed-temperature oven (GC1000D / GC1000T / GC1000W) and (F) an analyzer base sampling section (see Figure 3.1).

Note: There are two types of analyzer base sampling section, either the built-in type within GC1000 (the sample processor is embedded), or the external type (the sample processor is separate). Select the type best suited to the intended usage.

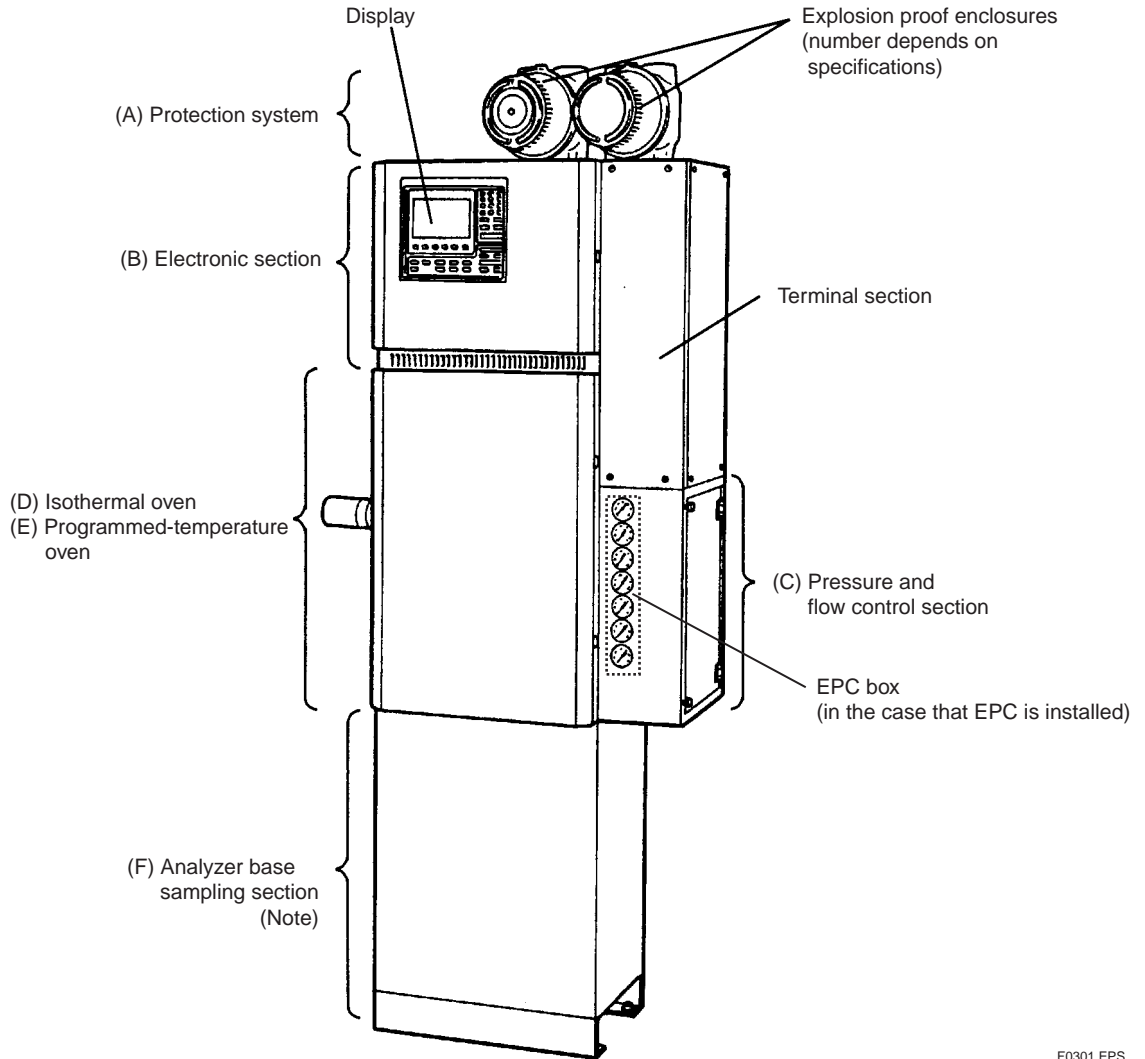

Figure 3.1 Analyzer Components

F0301.EPS

3.2 Components and Their Functions

3.2.1. Protection System

The protection system has an explosion-proof construction and is equipped with a built-in protection circuit. The power relay, pressure switch, timer, relays, override switch, etc. are internal to the instrument. The override function is particularly important for maintenance, since it allows the power to be turned on even if there is an internal pressure loss. The system monitors the internal pressures of the electronic section, isothermal oven and the programmed-temperature oven (GC1000D / GC1000T / GC1000W), and if any of them indicates an internal pressure lower than 392 Pa, it shuts down the power supply to those components. After a power shut-down, when the internal pressure is restored, the system automatically purges over the 12 minutes, then turns on the power again. Analyzers of non-explosion-proof type and with FM/CSA Type Y purging do not have this protection system.

3.2.2 Electronic Section

The electronic section has a pressurized protection/Type X purged structure and is designed for control of a detector, an isothermal oven, various valves and others, for processing and computation, and for output of the results. The LCD and operation keys on the front of the electronic section allow manual operation of the GC1000 Mark II.

3.2.3 Pressure and Flow Control Section

The pressure and flow control sections control and indicate the pressures of sample gases, standard gases, carrier gases, FID or FPD hydrogen (or nitrogen) for combustion, or FID or FPD air for combustion. Regulator valves or EPC is installed. It also contains pressure-reducing valves for controlling purge gases, the air for actuating valves or the vortex tube, an air-actuated valve for balancing atmospheric pressure, a vortex tube and a hydrogen restriction system.

3.2.4 Isothermal Oven

The isothermal oven has an pressurized protection / Type X purged structure. The temperature is set at a fixed level from 55 to 225°C (setting by 1°C unit). The isothermal oven contains valves such as the sample valve which is air-activated, the back flush valve, the column for separating a multi-component gas mixture into its individual components and leading the components to the detector in sequence, the detector for detecting the components, and the restrictor for controlling the gas flow rate, etc.

There are three types of detector, the thermal conductivity detector (TCD), the flame ionization detector (FID) and the flame photometric detector (FPD); either one or two of these detectors can be used simultaneously (however, the FPD can only be installed in the combustion chamber).

The component signals picked up by the detector are led to the electronic section for signal processing.

3.2.5 Programmed-temperature Oven

The programmed-temperature oven has an internal pressure protection / Type X purged structure. It contains a column that separates multi-component mixture samples into individual components and leads them to the detector in sequence. The temperature can be set to a fixed setting or it can be programmed. The allowable temperature range is 60 to 320°C without a cooling system, or 5 to 320°C with a cooling system, and the temperature can be set to rise from between 0.1 to 30°C/min (setting by 0.1°C unit). Up to three temperature-rise patterns can be programmed.

3.2.6 Analyzer Base Sampling Section

The analyzer base sampling section is equipped with sample and standard gas streams, and controls the sample pressure and flow rate. It also selectively sends the sample to be analyzed in a stream, and can switch the standard gas to the isothermal or the programmed-temperature oven by a valve depending on the signal sent from the electronic section.

If the analyzer does not contain the analyzer base sampling section, then samples can be processed externally by supplying air to a separate sampling section.

3.3 Block Diagram

(1) GC1000D/GC1000T/GC1000W Type X Purging

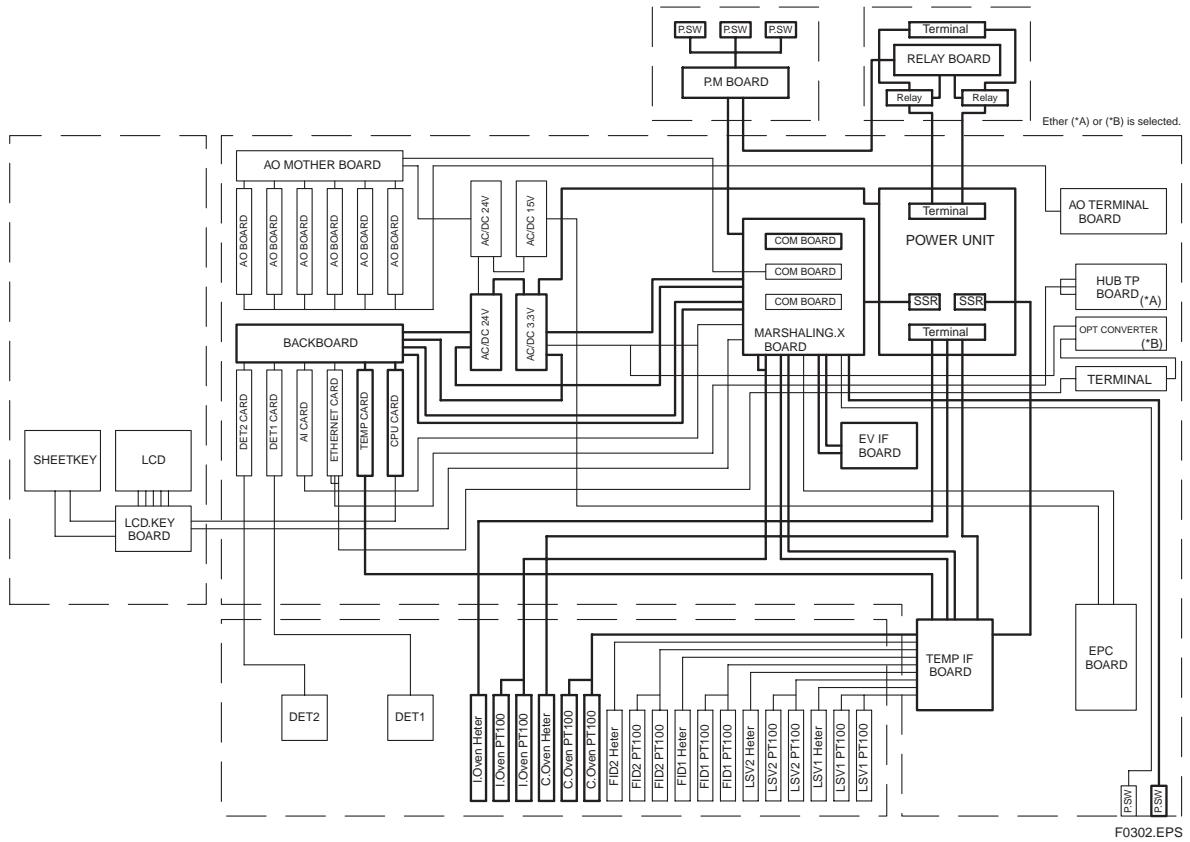

(2) GC1000T Type Y Purging

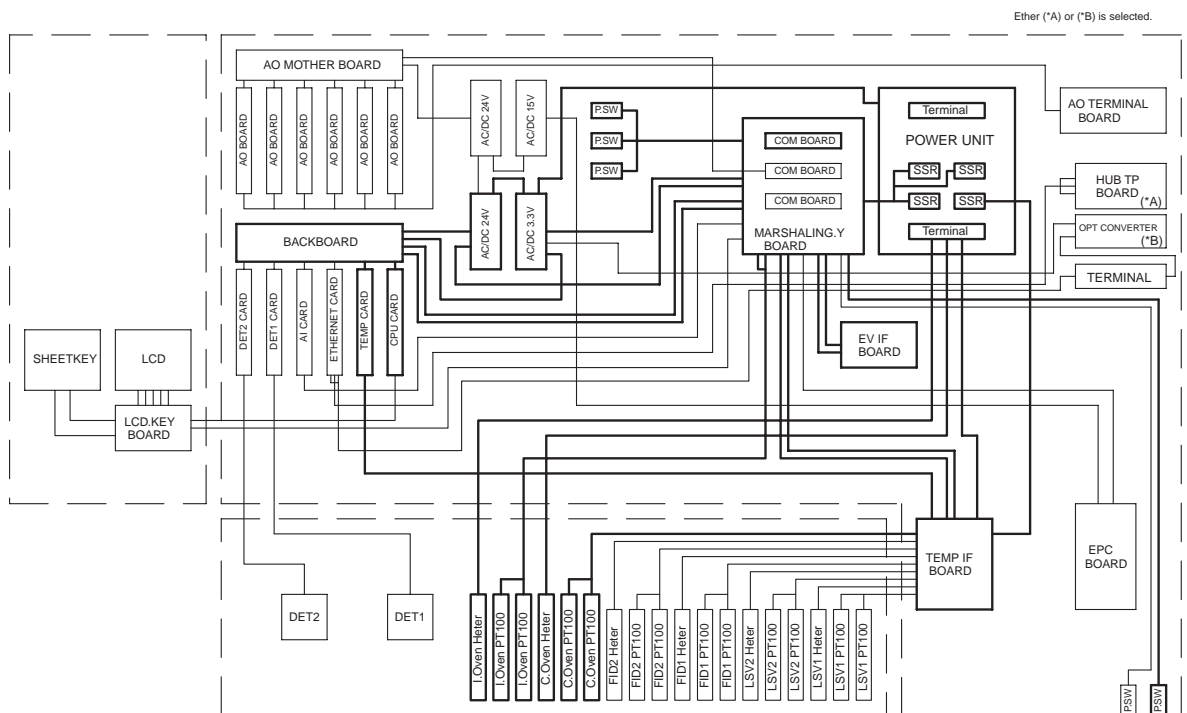

(3) GC1000S/GC1000E/GC1000C Type X Purging, with One Protection System

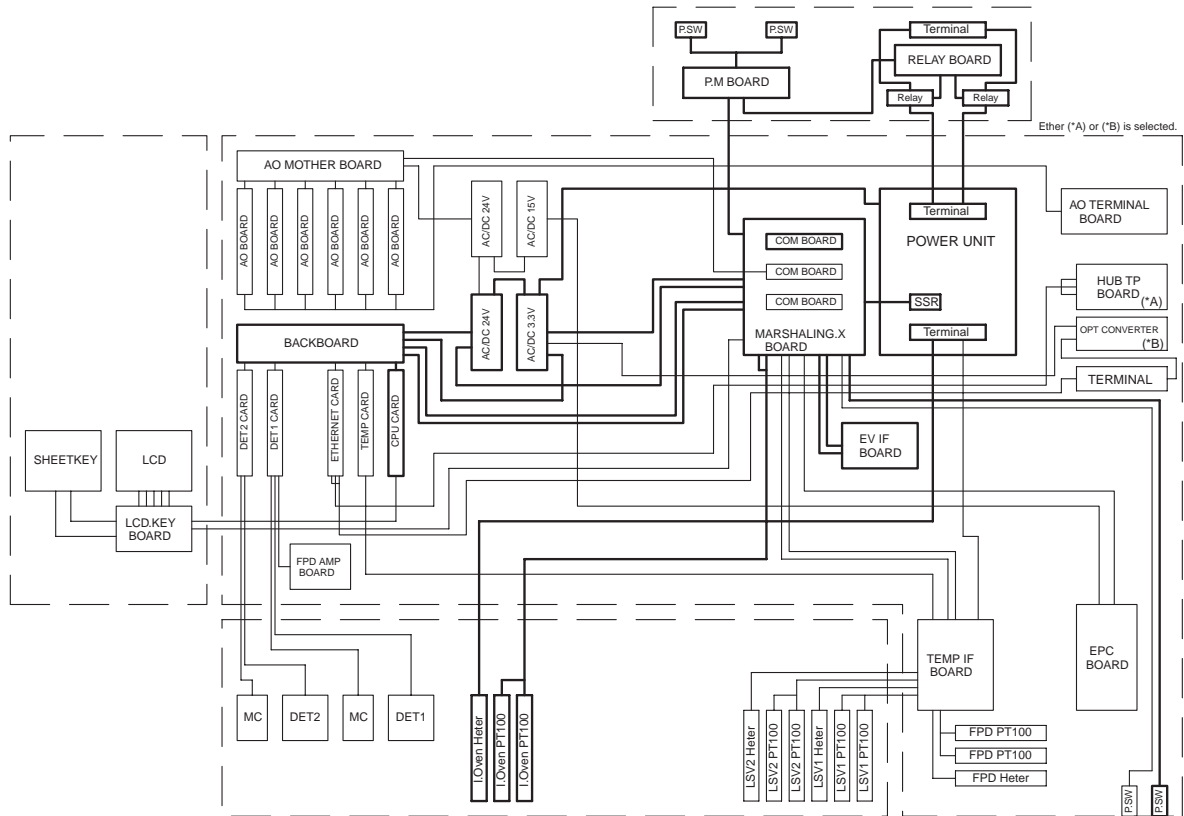

(4) GC1000S/GC1000E/GC1000C Type X Purging, with Two Protection Systems

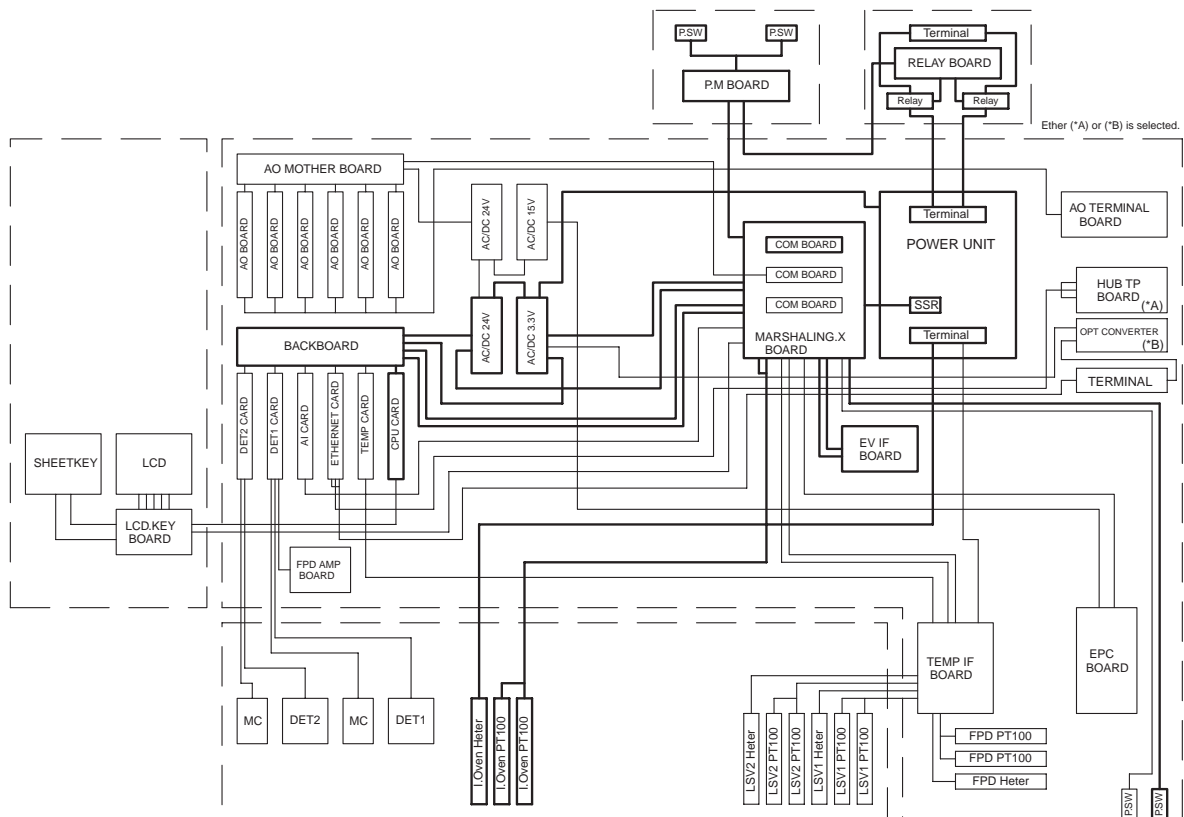

(5) GC1000E Type Y Purging

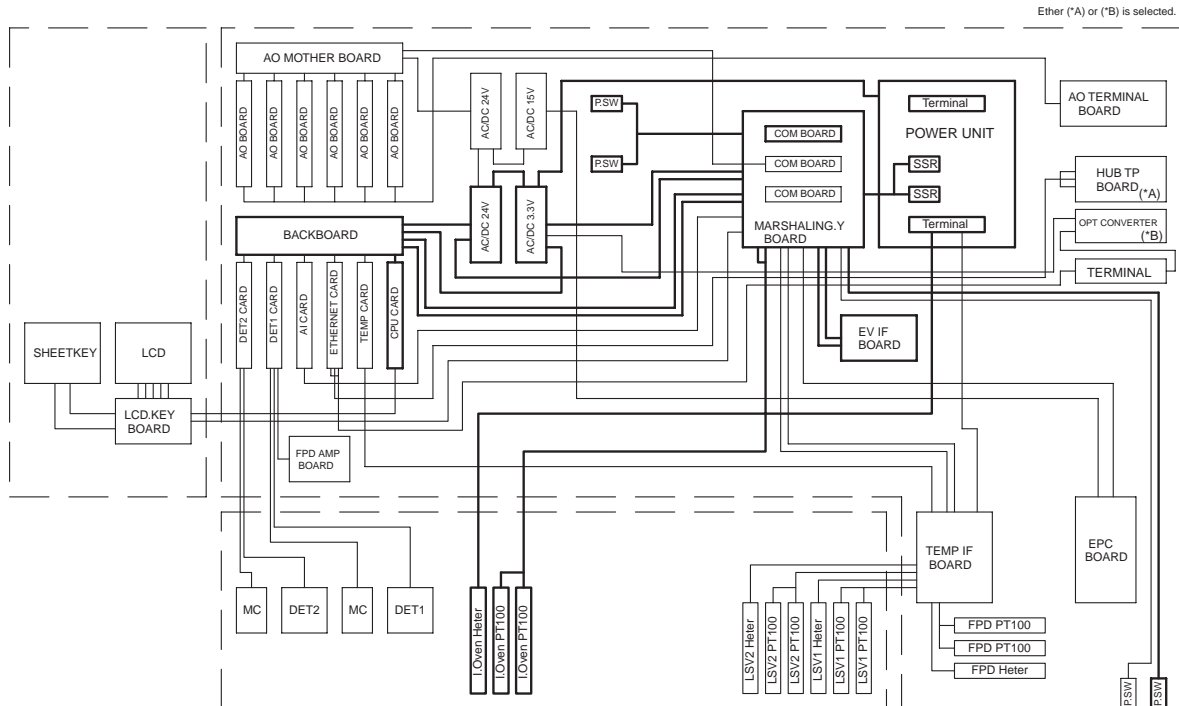

Name	Description
CPU CARD	Controls the whole GC1000 analyzer system (controls the temperature or the isothermal oven).
TEMP CARD	Controls the temperature of the components other than the isothermal oven.
ETHERNET CARD	Controls the TPC/IP.
AI CARD	Controls the analog input.
TCD CARD	Controls the TCD.
FID CARD	Controls the FID.
FPD CARD	Controls the FPD.
BACK BOARD	Connects various cards.
RELAY BOARD	Controls the relay inside the protection system.
P.M BOARD	Monitors the inner pressure.
AI TERMINAL BOARD	Equipped with the connection terminal for the analog input.
LCD.KEY BOARD	Relays among the LCD, sheet key an CPU card.
MARSHALING.X BOARD	Relays among various boards.
MARSHALING.Y BOARD	Relays among various boards (for Y purging).
COM BOARD	Controls various communications.
FPD AMP BOARD	An amplifier board for the FPD.
EV IF BOARD	For solenoid valves.
TEMP IF BOARD	Relays among the heaters except for the isothermal oven, sensors, and TEMP CARD.
EPC BOARD	Controls the EPC.
AO TERMINAL BOARD	Equipped with the connection terminal for the analog output.
HUB TP BOARD	A relay board for the analyzer bus.
AO MOTHER BOARD	Controls the analog output.
AO BOARD	An analog output board.

T0301.EPS

3.4 Internal Piping System Diagram

(1) GC1000D/GC1000T/GC1000W Type X Purging

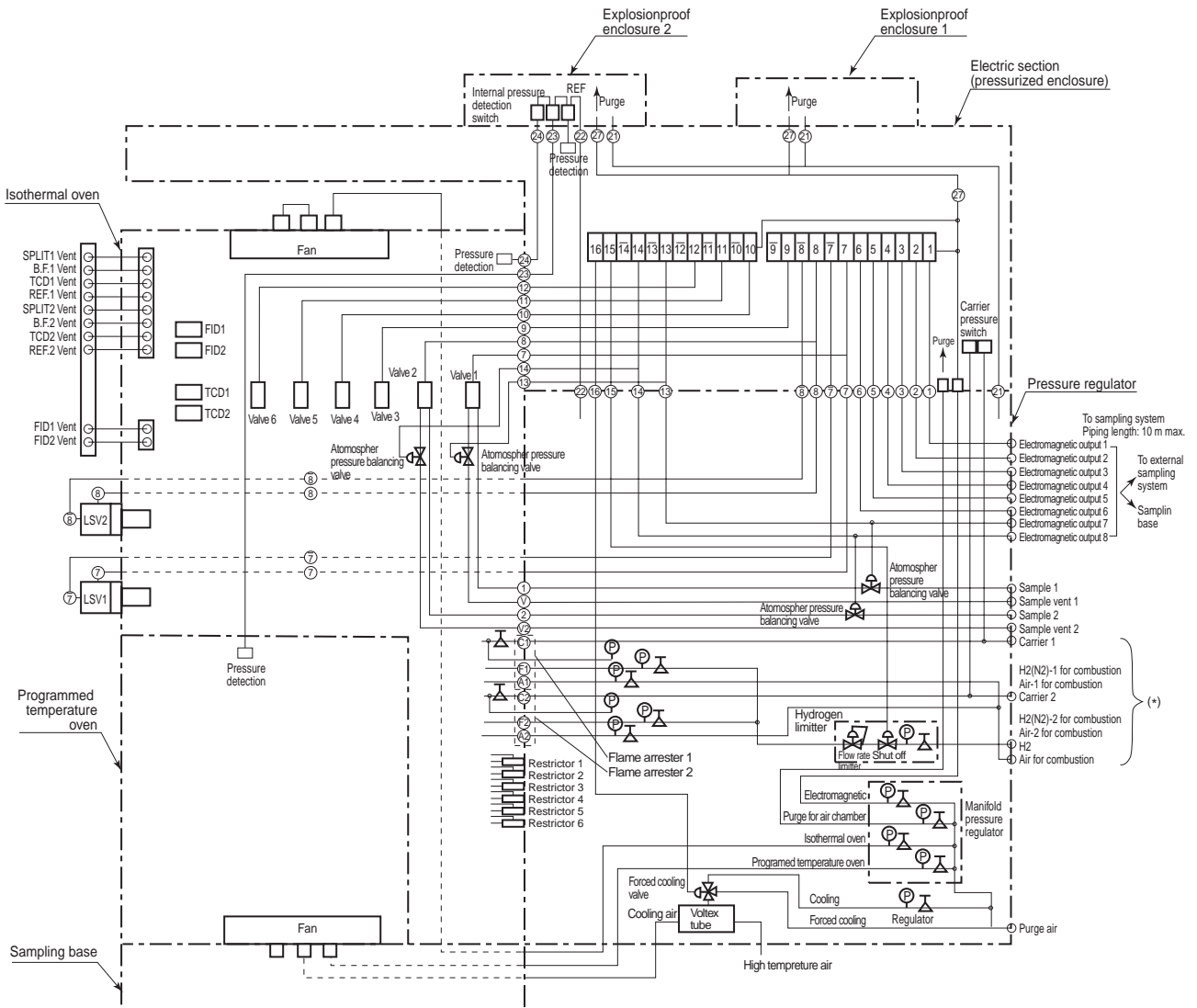

(*) In the case that EPC is installed.

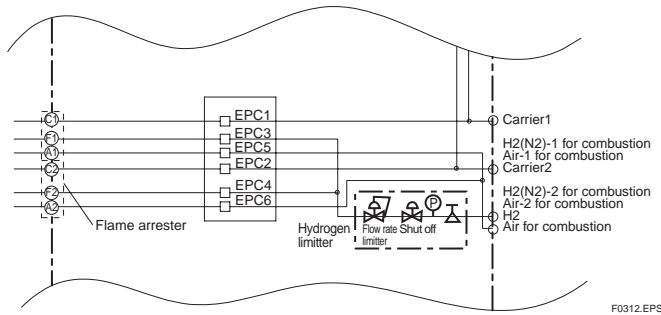

(2) GC1000T Type Y Purging

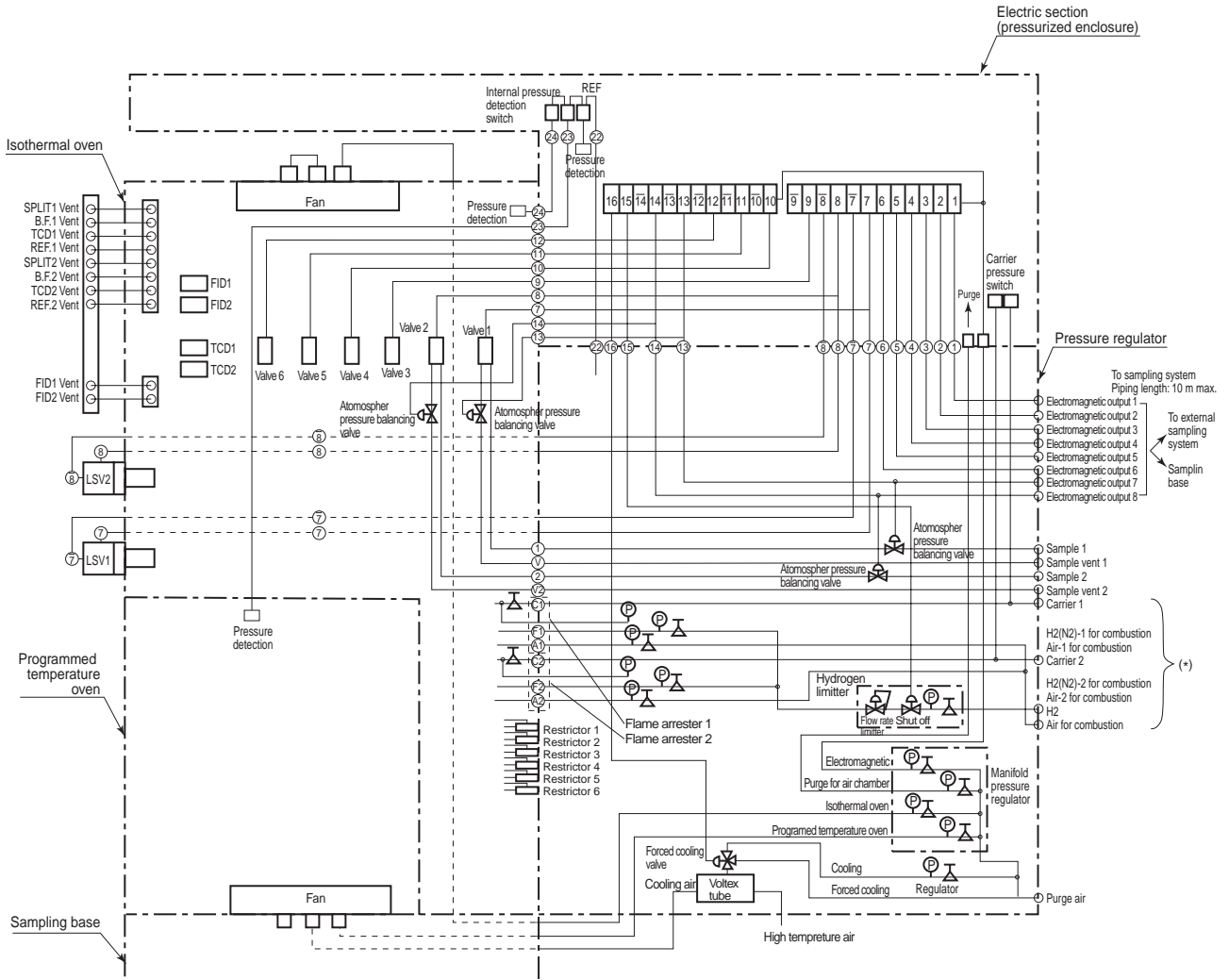

F0308.EPS

(*) In the case that EPC is installed.

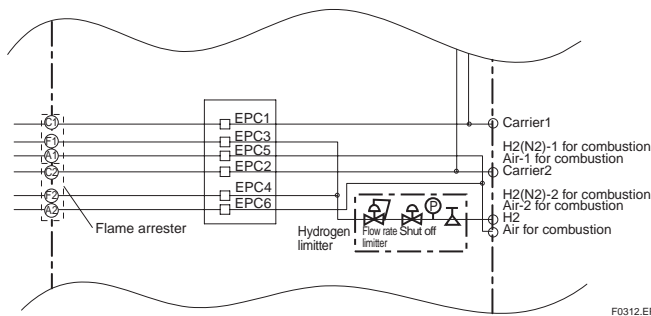

F0312.EPS

(3) GC1000S/GC1000E/GC1000C Type X Purging, with One Protection System

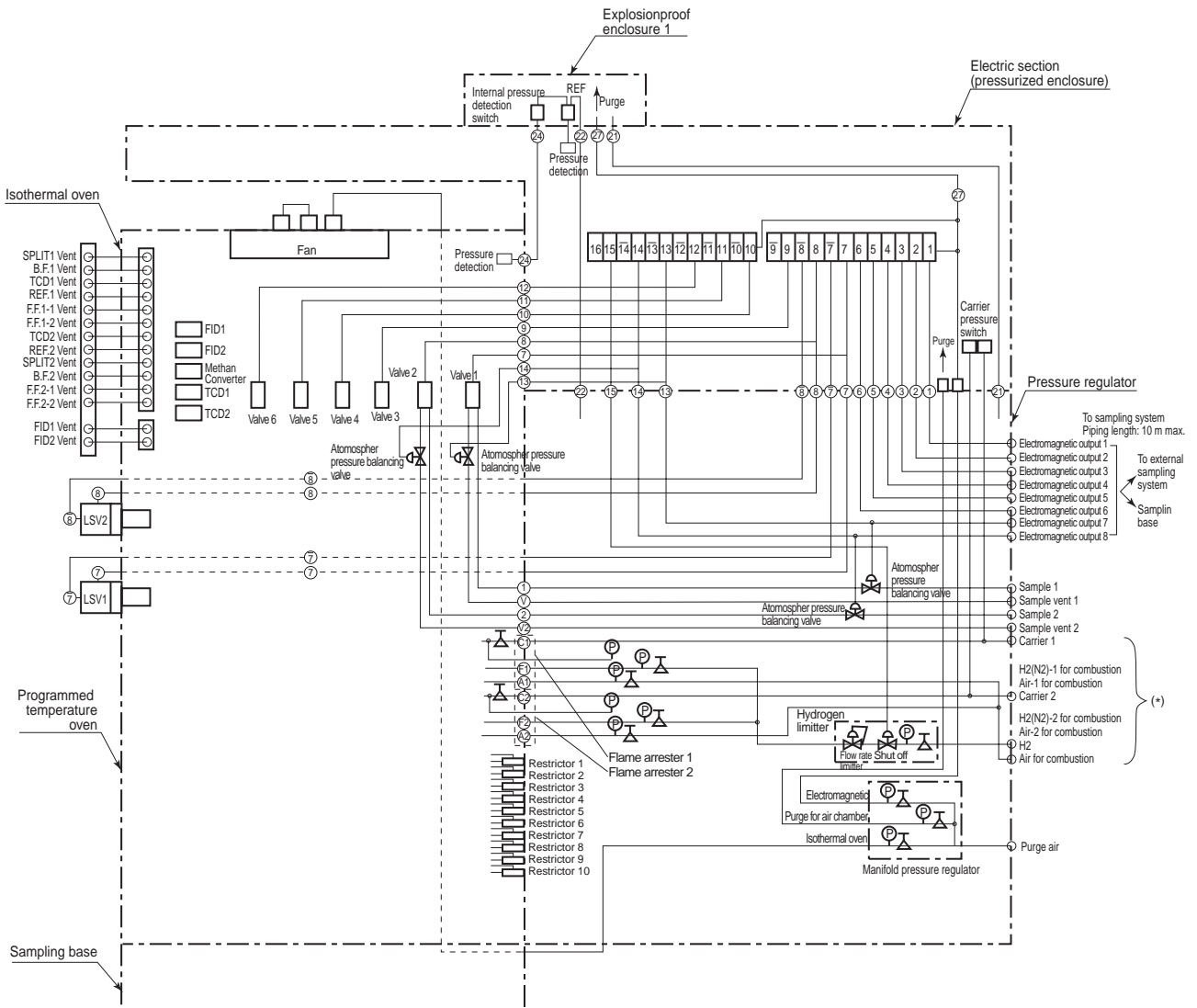

F0309.EPS

(*) In the case that EPC is installed.

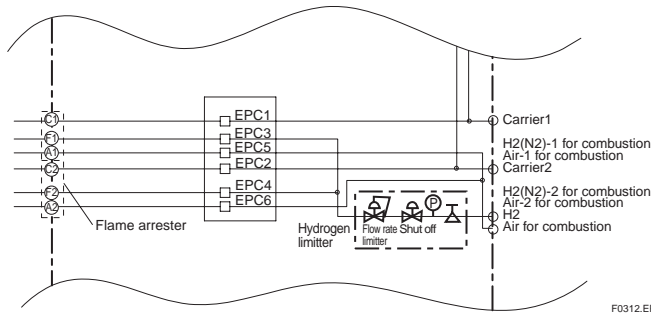

F0312.EPS

(4) GC1000S/GC1000E/GC1000C Type X Purging, with Two Protection Systems

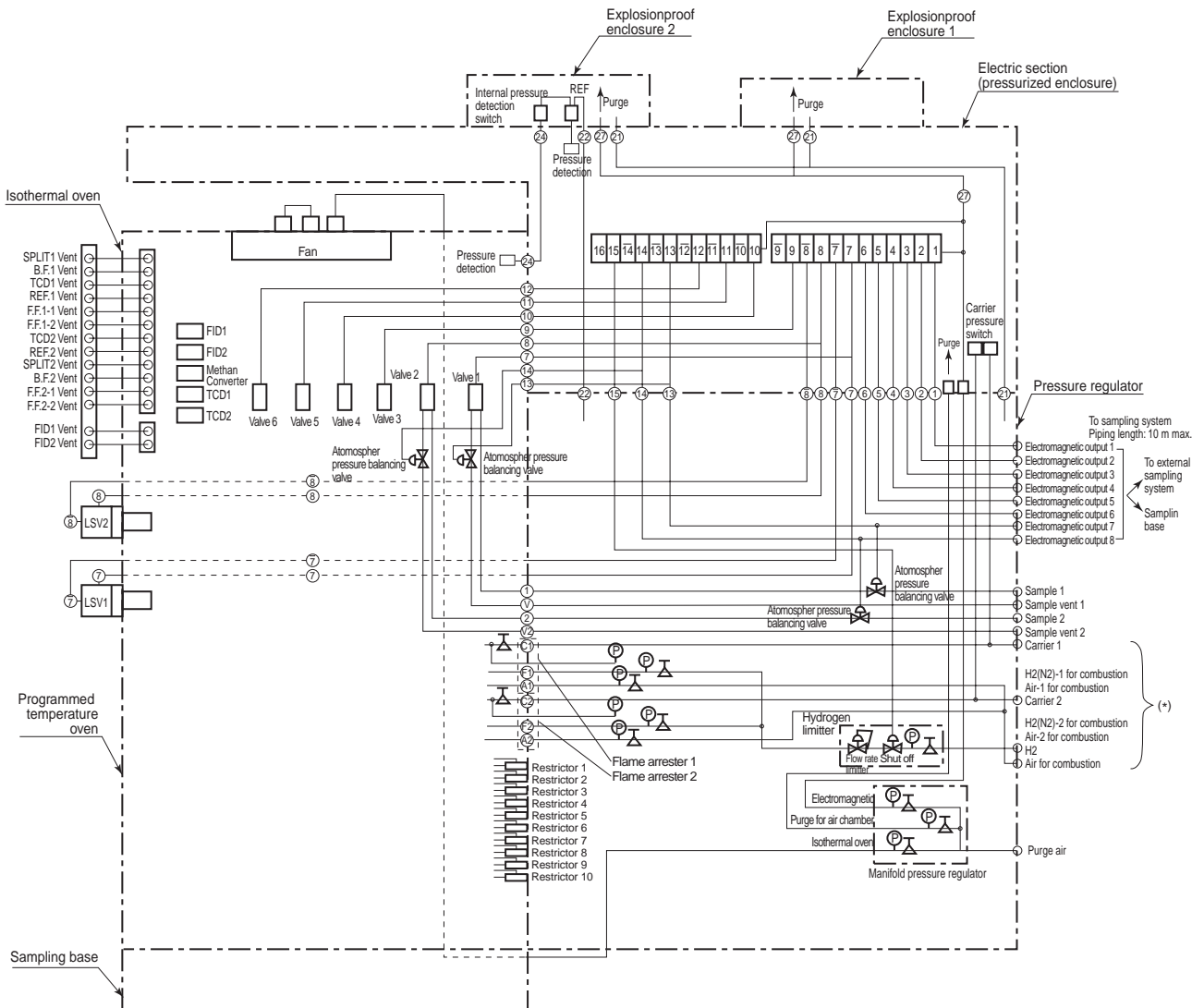

F0310.EPS

(*) In the case that EPC is installed.

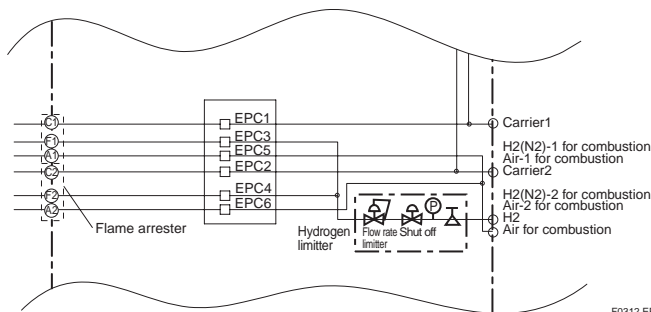

F0312.EPS

(5) GC1000E Type Y Purging

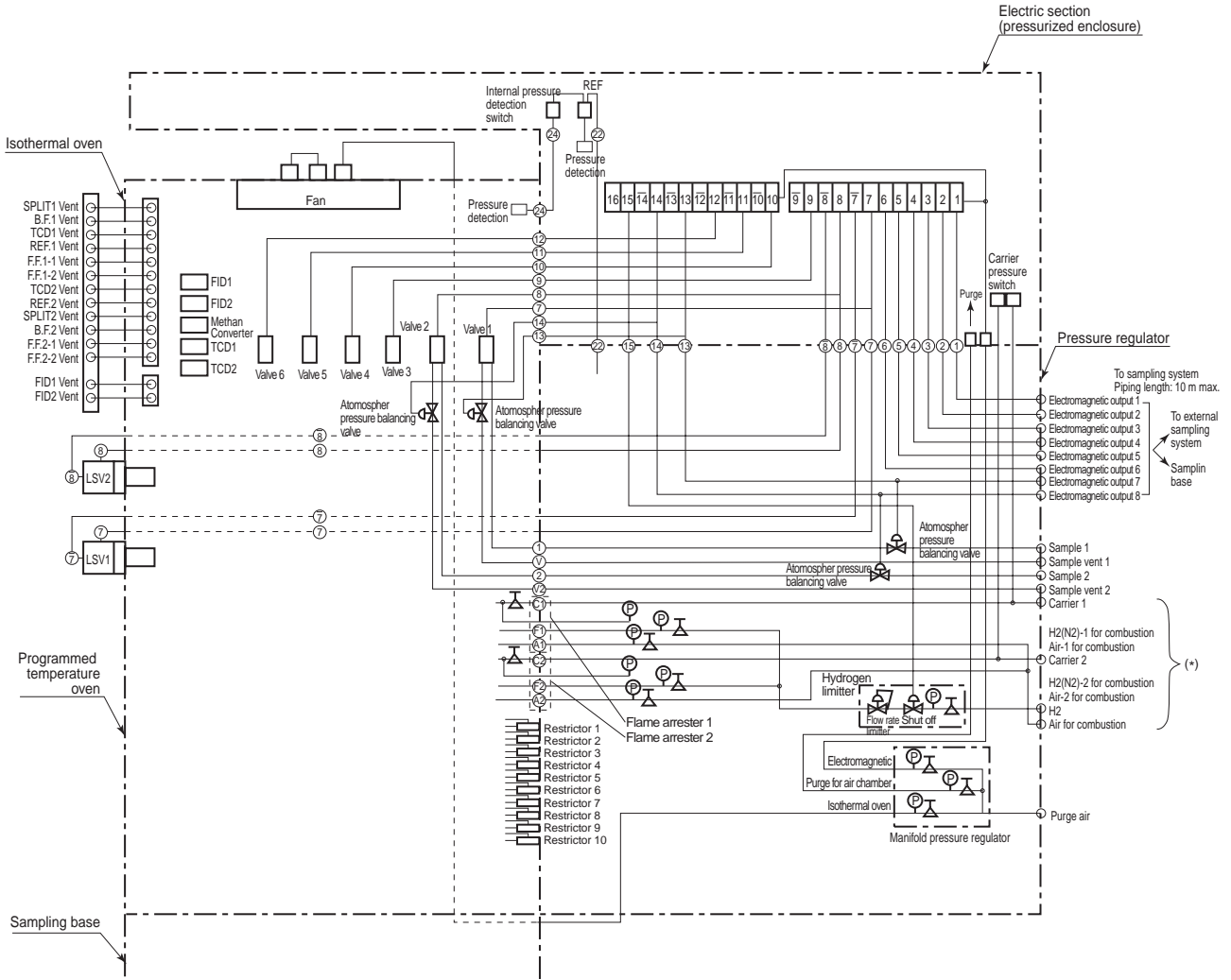

F0311.EPS

(*) In the case that EPC is installed.

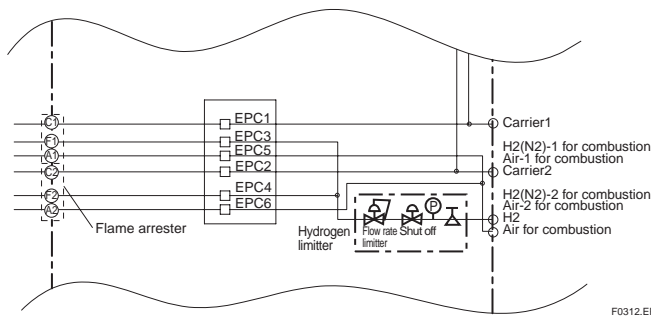

F0312.EPS

3.5 External Input and Output Signals

(1)Input

Item	Signal level	No.	Description
Analog Input	Isolated 4-20mA DC 1-5V DC 4-20mA DC (with 24 or 28V DC of Power)*1)	4	Accuracy : ±0.5%FS (-10 to 50°C) Function : Output of Current value*2) and Average value*3)
Contact Input	Specification : 5V DC, 20mA DC or more Input ON signal: 200Ω or less OFF signal: 100kΩ or more On operation: NC or NO (selectable)	8	Function : Alarm from outside Following command request Stream sequence assign Stream (cont.) assign Stream (1 cycle) assign Cal (Val) assign Change of Operation mode

*1) : 2-wire transmitter

*2) : It means the data which is averaged by every 1 second after filtered by a constant which the analog data is scanned by every 200msec. It can be output by DCS communication (Modbus protocol).

*3) : It means the current value which is set time in a cycle time.

T0302.EPS

(2)Output

Item	Signal level	No.	Description
Analog Output	Isolated or No-isolated 4-20mA DC Load: 300Ω or less	MAX. 36	Analysis result*1)
Contact Output	Specification (relay) : Voltage: 30V DC Current: 100mA DC On operation: NO or NC (selectable)	8	System alarm1 System alarm2 Component alarm (Conc./RT) Timing signal Code signal for stream ID (Max. 5 points)
Air output for stream valve	Air press : 350kPa	MAX. 8	Binary code signal for 9 to 31 stream (max.)

*1) : Analysis result (concentration, simulated distillation result, base level, signal level, noise level, Deviation calculation, Liner calculation1-5, Ratio, Separation coefficient, Calorific value, Density, Compressive factor, Wobbe Index)

T0303.EPS

(3)Communication

Item	Signal level	No.	Description
DCS communi-cation	Standard : RS422 (4wires, Full-Duplex) Specification : Start bit 1, Stop bit 1, Parity 1, ASCII7 bit, Without procedure or Hand shake Speed : 1200/2400/4800/9600/19200 bps(selectable) For explosion protection : RS422/RS232C converter is provided.(2 wires of power line is needed except the signal line) The transmission type is full duplex for RS232C.	1	Transmission : Analysis result*4) Calibration coefficient Alarm Reception : Operation request*5)
PC communi-cation	Standard : RS422 (4wires, Full-Duplex) Speed : 19.6/33.6kbps For explosion protection : RS422/RS232C converter is provided.(2 wires of power line is needed except the signal line) The transmission type is full duplex for RS232C.	1	GCMT (GC Maintenance Terminal) Transmission : Analysis result*4) Operation information*6) Parameter list Reception : Operation request*5) Change of Parameter list

*1) : Analysis result(concentration, simulated distillation result, base level, signal level, noise level, Deviation calculation, Liner calculation1-5, Ratio, Separation coefficient, Calorific value, Density, Compressive factor, Wobbe Index)

*2) : Operation request, (Stream sequence assign, Stream (cont.) assign, Run command, Stop command, Pause command, Range change)

*3) : Operation Information(Chromatogram, Oven temperature, measuring stream, Valve ON/OFF etc...)

T0304.EPS

4. Outline of Software

4.1 Status and Operation Mode

The GC1000 Mark II has the following statuses:

- Process: Normal measurement, calibration and validation
- Manual: Manual operation
- Lab: Measurement with automatic peak detection, like a laboratory GC

The GC1000 Mark II has the following operation modes:

- Stop: Mode in which the measurement stops
- Run: Mode in which the measurement is running
- Pause: Mode in which the measurement pauses

Figure 4.1 shows the transitions of statuses and operation modes.

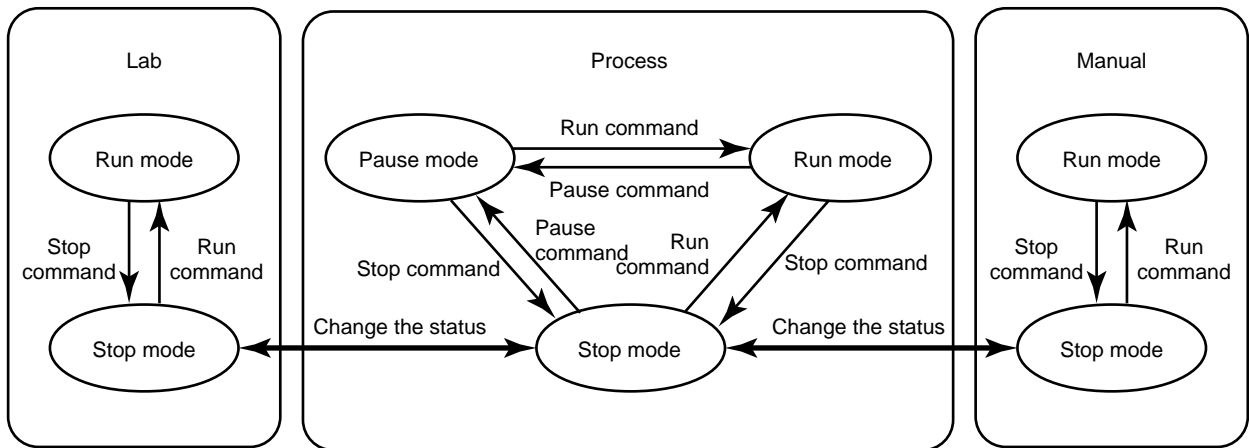

F0401.EPS

Figure 4.1 Status and Operation Mode Transition Diagram

When the LCD panel on the GC1000 Mark II or the LCD emulator on a personal computer (PC) connected with the GC1000 Mark II is used, by changing the operation panel to the manual operation panel or lab operation panel, the status will change from Process to Manual or Lab. Likewise, by changing the manual operation panel or lab operation panel to the operation panel, the status will change from Manual or Lab to Process.

When the GCMT on a PC connected with the GC1000 Mark II is used, the status can be changed through command button operation or menu-driven operation.

The following pages describe each status and operation in detail.

4.1.1 Process

In the Process status normal process measurements, calibration, and validation are performed. When power is applied, the status enters Process.

The Process status contains the following measurement statuses.

- Stream Sequence: Continuously measures streams in order specified in Stream Sequence
- Stream (continuous): Continuously measures the specified stream
- Stream (1 cycle): Measures the specified stream once
- Calibration/Validation: Performs calibration or validation of the specified number

Figure 4.2 shows the transitions of measurement statuses.

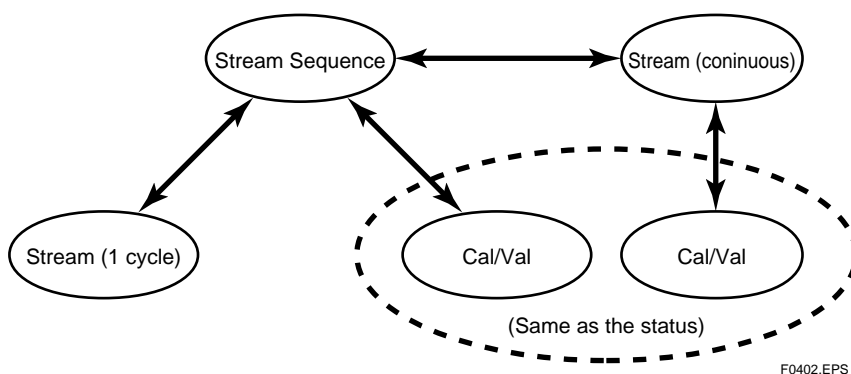

Note: When Calibration/Validation has been specified from Stream Sequence, the measurement status returns to Stream Sequence after the completion of calibration/validation. When Calibration/Validation has been specified from Stream (continuous), the measurement status returns to Stream (continuous) after the completion of calibration/validation.

Figure 4.2 Measurement Status Transition Diagram

The following explain each measurement status in detail.

(1) Stream Sequence

In the Stream Sequence status, the analyzer continuously measures multiple streams in order. When power is applied, the measurement status enters Stream Sequence. Four kinds of stream sequences can be used with the GC1000 Mark II. For each stream sequence 31 streams can be set in order. If number "0" is set as a stream number, the measurement skips the order and goes to the stream specified in the following number. Note that number "0" cannot be set as the first stream number, which needs any number between 1 and 31 to be specified.

(2) Stream (continuous)

In the Stream (continuous) status, the analyzer continuously measures the specified stream. With the GC1000 Mark II, 31 streams can be specified. In the Stream (continuous) measurement status, the analyzer measures the stream specified from among the 31 streams.

(3) Stream (1 cycle)

In the Stream (1 cycle) status, the GC1000 Mark II measures the specified stream once. Like Stream (continuous), the analyzer measures the stream specified from among the 31 streams.

(4) Calibration/Validation

In the Calibration/Validation status, calibration or validation is performed using a standard sample. Validation is to verify, using a standard sample, whether the measurement of the GC1000 Mark II is normal. This function can be used in combination with calibration: calibration is conducted when the increased error between a measurement result and a standard sample is seen during the regular validation.

Three ways of calibration and three ways of validation can be used with the GC1000 Mark II.

There are three methods for Calibration/Validation: automatic, semiautomatic and manual. The following explain the actions of three methods.

- **Automatic**

Calibration or validation is conducted automatically at the specified time. This function is only available when automatic valves are used for streams for calibration or validation.

When Calibration/Validation is set to automatic, the analyzer starts calibration or validation at the specified starting time and subsequently conducts calibration or validation every time after the specified interval time elapses. When the operation mode is in Stop or Pause at the time of automatic calibration or validation, the calibration or validation for the time is cancelled.

- **Semiautomatic**

When the calibration number or validation number is specified, the valves for streams for calibration or validation automatically open and the analyzer performs calibration or validation. This function is only available when automatic valves are used for the stream.

- **Manual**

When the calibration number or validation number is specified, the valves for all streams are closed so that the analyzer is ready to allow a standard sample to flow. The standard sample is supplied manually for displacement, making the analyzer ready to accept a command. After the displacement is conducted adequately, the analyzer performs calibration or validation by the start command.

Each measurement status has the following operation modes, with the exception of the Stream (1 cycle) and Calibration/Validation statuses which do not have Stop and Pause.

- **Stop:** Mode in which the measurement stops
- **Run:** Mode in which the measurement is running
- **Pause:** Mode in which the Run mode pauses

For the transitions of the operation modes, refer to Figure 4.1.

To transfer from the Run mode to the Stop mode, two commands are used: stop command and forced stop command, which are explained below.

- **Stop command**

The measurement stops after an ongoing measurement has been completed.

The following explain each operation mode in detail.

(1) Stop

In the Stop mode the measurement stops. When power is applied, the operation mode enters Stop. Settings should be changed in this Stop mode.



CAUTION

If settings are changed in an operation mode other than the Stop mode, the analyzer may not accept the change and run under the previous setting.

When the operation mode is transferred to the Stop mode from others, the on-off statuses of various valves and stream valves remains unchanged.

(2) Run

In the Run mode, the measurement runs. If the Auto Start Set is set to Enabled, the GC1000 Mark II automatically enters the Run mode after the time set for the "Auto start time" elapses after power is applied. When the operation mode is transferred from the Stop mode to the Run mode, the measurement starts after the Warming up time for displacement in the sample stream elapses. For the Warming up time, see Section 4.3, "Method". If a level 1 alarm occurs during the Run mode, the mode changes to the Stop mode after an ongoing measurement of the stream has been completed.

(3) Pause

In the Pause mode, the measurement pauses at the specified Pause Time. For the Pause Time, see Section 4.3, "Method."

When the operation mode is transferred from the Pause mode to the Run mode, the measurement resumes at the Pause Time.

When the operation mode is transferred from the Stop mode to the Pause mode, the on-off statuses of various valves including stream valves become those at the Pause Time of the stream to be measured next.

4.1.2 Manual

In the Manual status, various operations and measurements can be performed manually. The operations available in the Manual mode are:

- On/off of various valves
- On/off of stream valves
- On/off of several heaters
- On/off of several types of detector (only On for FID and FPD)

When the status is transferred from Process to Manual, all the various valves and stream valves turn Off.

The Manual mode contains the following operation modes.

- Stop: Mode in which measurement stops
- Run: Mode in which measurement runs

For the transitions of the operation modes, refer to Figure 4.1.

The following explain each operation mode in detail.

(1) Stop

In the Stop mode the manual measurement stops.

(2) Run

In the Run mode the manual measurement runs. During the Run mode, the GC1000 Mark II detects peaks automatically until the mode turns to Stop. When the mode turns to Stop, the concentration in area percentage is calculated from the area of peaks detected. The calculated concentration values are displayed on the Laboratory Analysis Results display panel. For five seconds after the operation mode turns from Run to Stop, the GC1000 Mark II does not accept the run command in order to process analysis calculations and others.

4.1.3 Lab

In the Lab status the lab measurement runs. The GC1000 Mark II performs continuous measurements for times specified in the lab settings.

In the Run mode in Process, peaks are detected according to the on/off of the set gate, while in Lab, peaks are detected automatically like a laboratory GC. This mode can be used for determining gate timing when a column system is changed.

The Lab mode contains the following operation modes.

- Stop: Mode in which measurement stops
- Run: Mode in which measurement runs

For the transitions of the operation modes, refer to Figure 4.1.

The following explain each operation mode in detail.

(1) Stop

In the Stop mode the lab measurement stops.

(2) Run

In the Run mode the lab measurement runs. In the Run mode, GC1000 Mark II performs measurements according to the lab settings. If a level 1 alarm occurs during the Run mode, the mode changes to the Stop mode after an ongoing lab measurement has been completed.

4.2 Stream

In the GC1000 Mark II, 31 streams can be used. Parameters needed to be specified for streams are:

- **Stream valve number**

Any one stream valve number from among the numbers of 1 to 31 should be specified for a stream.

If the stream valves are automatic, the stream valve of the specified valve turns on/off. If the stream valves are manual, this setting does not have any effect on the operation.

The same stream valve number can be specified for different streams. When multiple measurements are performed in one stream, the same stream valve number should be specified.

A standard sample stream should be specified as one of the streams.

- **Method number**

Any number from 1 to 4 should be specified for a method number.

There are three types for the stream:

- **Measurement stream**

Used for measuring process samples.

- **Validation stream**

Comparing measured results before and after calibration, or checking if the GC1000 Mark II is operating properly can be performed using a standard sample. The validation stream is used for standard sample measurement in such case.

- **Calibration stream**

Used for measuring a standard sample at calibration. The calibration stream may be used in combination with the validation stream.

4.3 Method

Activation timing for various valves and parameters with regard to the temperature of the isothermal/programmed-temperature ovens should be specified for Method. Four Methods can be used with the GC1000 Mark II. Parameters needed to be specified are described below. For setting procedures, refer to the LCD Panel Operation Manual, IM 11B03A03-05 E.

• Analysis cycle

Time from start (0 second) to stop of analysis

• Warming up time

Time required for displacement in sample streams. An appropriate displacement time should be determined considering the diameter and length of the sample stream tubing, sample flow rate and delay time.

A positive value should be specified for the Warming up time. But displacement in sample streams is implemented before the start of analysis (0 second) so that the Warming up time actually acts as a negative value.

• Peak detection stop time

Time to stop peak detection compulsorily, which is usually specified to around five seconds earlier than the pause time. The time must be the analysis cycle time minus one second, or less.

In case of the GC1000D/GC1000T/GC1000W, the heater should be turned off at the time of peak detection stop time.

• Pause time

Time when the GC1000 Mark II can be stopped without adversely affecting the column system. Usually the pause time should be set after peaks of all components have been eluted (after the peak detection stop time) for the analysis cycle time minus 3 seconds, or less.

• DO on time/DO off time

These can be used for notifying a supervisory computer or system of analysis end timing and other information by using contacts. They can also be used as a reading signal when analog outputs are employed.

• Stream valve on time/stream valve off time

Time to turn on/off stream valves. As stream valves usually turns on from the Warming up time, the stream valve on time should be set as a negative value. The values to be set should be the Warming up time minus one second, or more, and the analysis cycle time minus two seconds, or less.

• V1 to V8 on/off time

Time to turn on/off valve 1 to valve 8 - sample valves, back flush valves, column switching valves, and atmosphere balance valves. On/off can be set for three times each. The time to be set should be the Warming up time minus one second, or more, and the Analysis Cycle Time minus two seconds, or less.

• Initial control temperature

Displayed on the GC1000D/GC1000T/GC1000W that uses a temperature program. The temperature of the programmed-temperature oven at the start of analysis should be specified.

• Initial temperature time

Displayed on the GC1000D/GC1000T/GC1000W that uses a temperature program. The time for holding the initial control temperature should be specified.

- The first temperature gradient/first control temperature/first temperature time (only for the GC1000D/GC1000T/GC1000W)
- The second temperature gradient/second control temperature/second temperature time (only for the GC1000D/GC1000T/GC1000W)
- The third temperature gradient/third control temperature /third temperature time (only for the GC1000D/GC1000T/GC1000W)
- Initial control pressure

Displayed when EPC is installed that uses a pressure program. The pressure at the start of analysis should be specified.

- Initial pressure time

Displayed when EPC is installed that uses a pressure program. The time for holding the initial control pressure should be specified.

- First pressure gradient/first control pressure/first control time (only when EPC is installed)
- Second pressure gradient/second control pressure/second control time (only when EPC is installed)
- Third pressure gradient/third control pressure/third control time (only when EPC is installed)

In the GC1000D/GC1000T/GC1000W, three stages of temperature program can be specified. Figure 4.3 shows the operations for temperature programs.

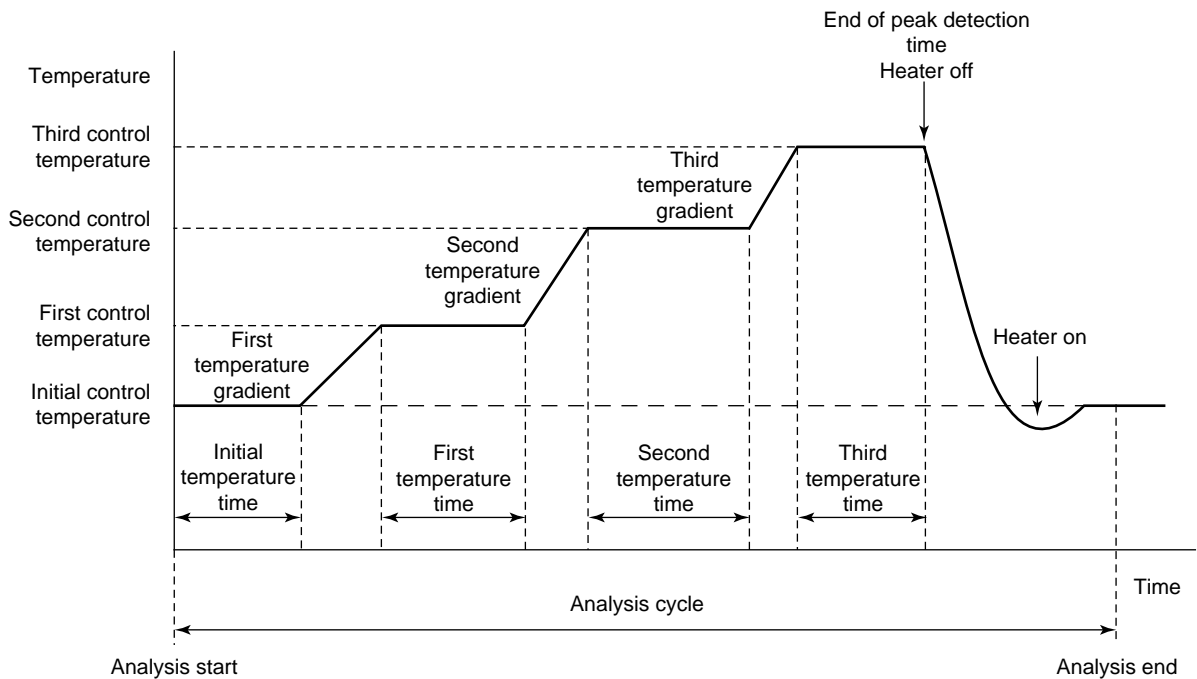

Figure 4.3 Operation for Temperature Programs

F0403.EPS

In the case that EPC is installed, three stages of pressure program can be specified. Figure 4.4 shows the operations for EPC pressure programs.

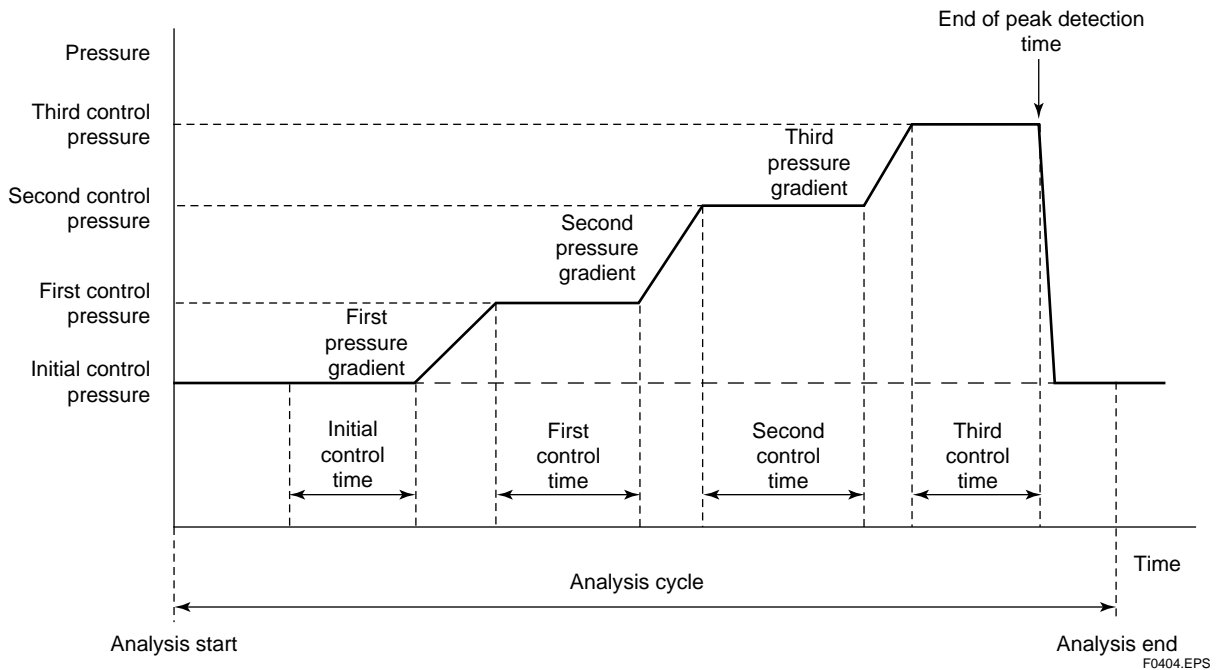

Figure 4.4 Operation for EPC Pressure Programs

4.4 Description of Actions

Actions under the conditions below - stream sequence in Table 4.1, calibration in Table 4.2, and validation in Table 4.3 - are described as examples.

Table 4.1

	First stream number	Second stream number	Third stream number	Fourth stream number
Stream Sequence 1	Stream 1	Stream 2	Stream 3	0
Stream Sequence 2	Stream 4	0	Stream 5	Stream 6

T0401.EPS

Table 4.2

	Calibration stream number	Measuring times	Validation stream number
Calibration 1	Stream 7	2	Stream 8

T0402.EPS

Table 4.3

	Validation stream number	Measuring times
Validation 1	Stream 9	2

T0403.EPS

4.4.1 Actions of Stream Sequence

The same action is performed when the Stream Sequence is specified at any timing during analysis.

- (1) An action when the operation mode is transferred from Stop to Run while the measurement status is in Stream Sequence 1, is shown in Figure 4.5.

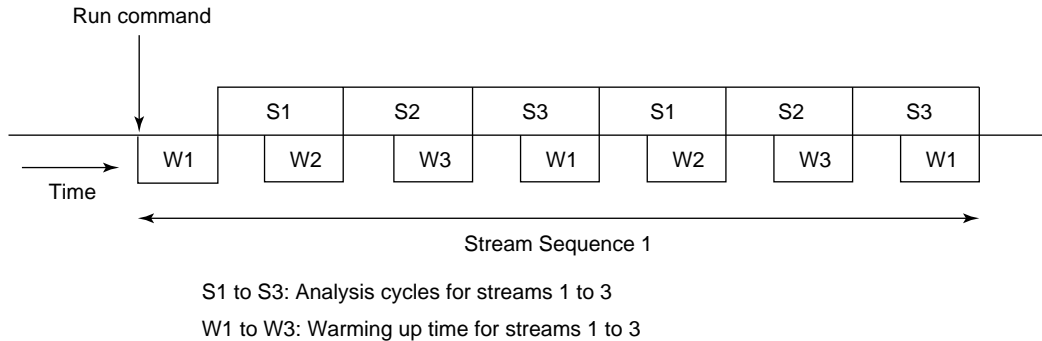

Figure 4.5 Action of Stream Sequence (1)

- (2) An action when Stream Sequence 2 is specified while the measurement status is in Stream Sequence 1 and the operation mode is in Run, is shown in Figure 4.6.

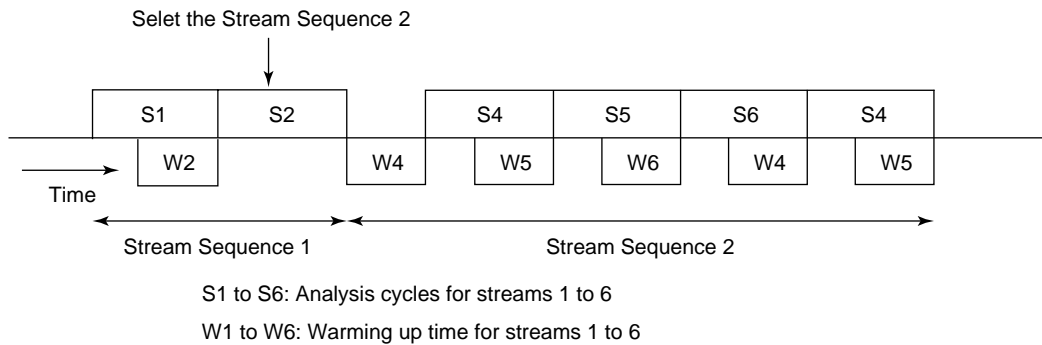

Figure 4.6 Action of Stream Sequence (2)

- (3) An action when Stream Sequence 1 is specified while the measurement status is in Stream (continuous) 2 and the operation mode is in Run, is shown in Figure 4.7.

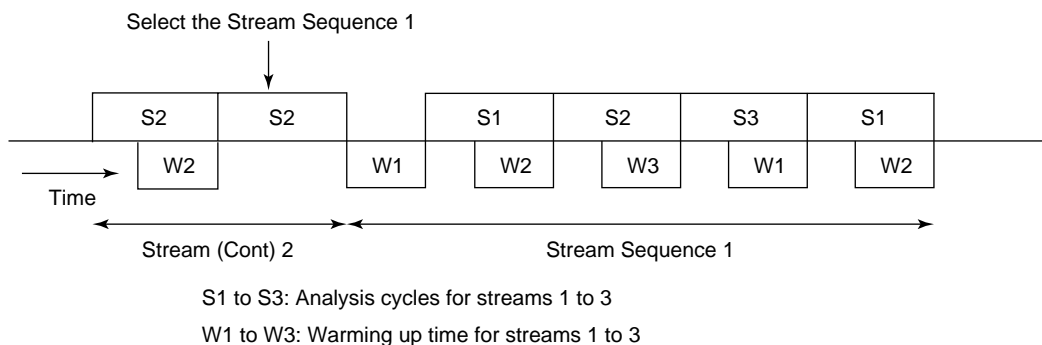

Figure 4.7 Action of Stream Sequence (3)

- (4) When Stream Sequence 1 is specified while the measurement status is in Stream Sequence 2 to 4 or in Stream (continuous) 1 to 31 and the operation mode is in Stop or in Pause, the measurement status is immediately changed to Stream Sequence 1 and the operation mode to Stop. The same action is performed when Stream Sequence 2 to 4 is specified.

4.4.2 Actions of Stream (Continuous)

Actions are different according to the timing when Stream (continuous) is specified.

- (1) An action when the operation mode is transferred from Stop to Run while the measurement status is in Stream (continuous) 2 and the operation mode is in Stop, is shown in Figure 4.8.

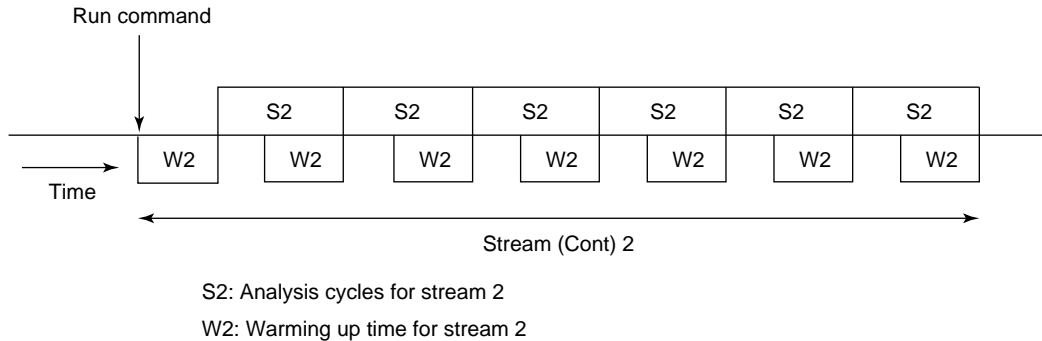

F0408.EPS

Figure 4.8 Action of Stream (Continuous) (1)

- (2) An action when Stream (continuous) 3 is specified before the following warming up time starts while the measurement status is in Stream (continuous) 2 and the operation mode is in Run (i.e., Stream 2 is being measured), is shown in Figure 4.9.

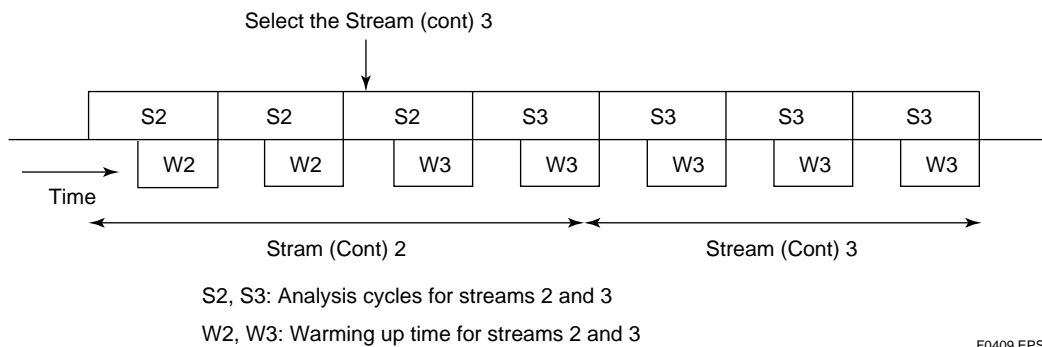

F0409.EPS

Figure 4.9 Action of Stream (Continuous) (2)

- (3) An action when Stream (continuous) 3 is specified after the following warming up time has started while the measurement status is in Stream (continuous) 2 and the operation mode is in Run (i.e., Stream 2 is being measured), is shown in Figure 4.10.

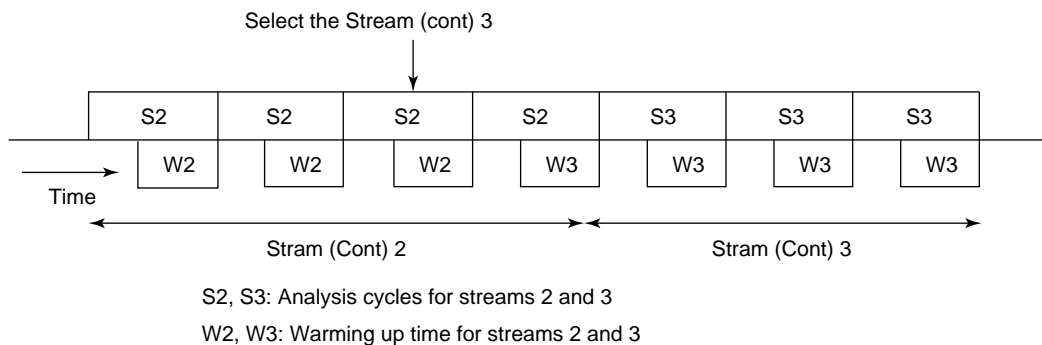

F0410.EPS

Figure 4.10 Action of Stream (Continuous) (3)

- (4) An action when Stream (continuous) 4 is specified while the measurement status is in Stream Sequence 1 and the operation mode is in Run, is shown in figure 4.11.

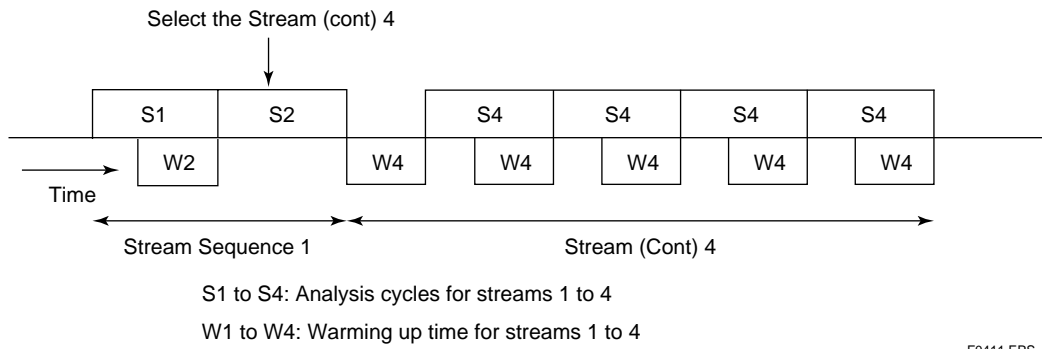

F0411.EPS

Figure 4.11 Action of Stream (Continuous) (4)

- (5) When stream (continuous) 1 is specified while the measurement status is in Stream Sequence 1 to 4 or in Stream (continuous) 2 to 31 and the operation mode is in Stop or in Pause, the measurement status is immediately changed to Stream (continuous) 1 and the operation mode to Stop. The same action is performed when Stream (continuous) 2 to 31 is specified.

4.4.3 Actions of Stream (1 cycle)

Stream (1 cycle) 1 to 31 is allowed to be specified only when the measurement status is in Stream Sequence 1 to 4. The same action is performed when the Stream (1 cycle) is specified at any timing during analysis.

- (1) When Stream (1 cycle) 1 to 31 is specified while the measurement status is in Stream Sequence 1 to 4 and the operation mode is in Stop or in Pause, the specified stream is measured once and then the measurement status turns to Stream Sequence 1 and the operation mode returns to Stop.
- (2) An action when Stream (1 cycle) 4 is specified while the measurement status is in Stream Sequence 1 and the operation mode is in Run, is shown in Figure 4.12.

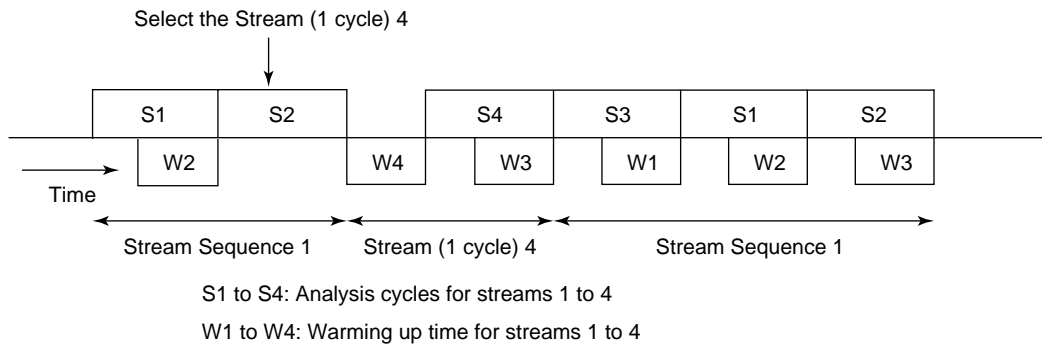

F0412.EPS

Figure 4.12 Action of Stream (1 cycle)

4.4.4 Actions of Calibration

Calibration 1 to 3 is allowed to be specified only when the measurement status is in Stream Sequence 1 to 4 or in Stream (continuous) 1 to 4. Actions are different according to the specified calibration (validation) method.

• Automatic Calibration

The same action is performed when the starting time comes at any timing during analysis.

- (1) An action when the starting time of Automatic Calibration 1 comes while the measurement status is in Stream Sequence 1 and the operation mode is in Run, is shown in Figure 4.13.

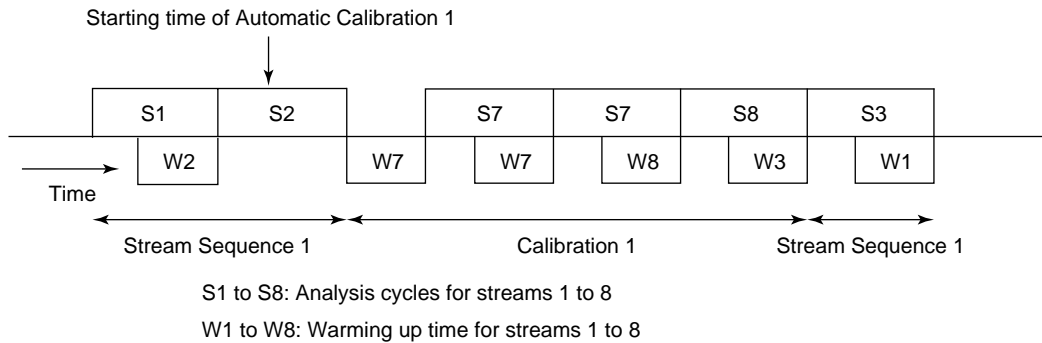

F0413.EPS

Figure 4.13 Action of Automatic Calibration (1)

- (2) An action when the starting time of Automatic Calibration 1 comes while the measurement status is in Stream (continuous) 1 and the operation mode is in Run, is shown in Figure 4.14.

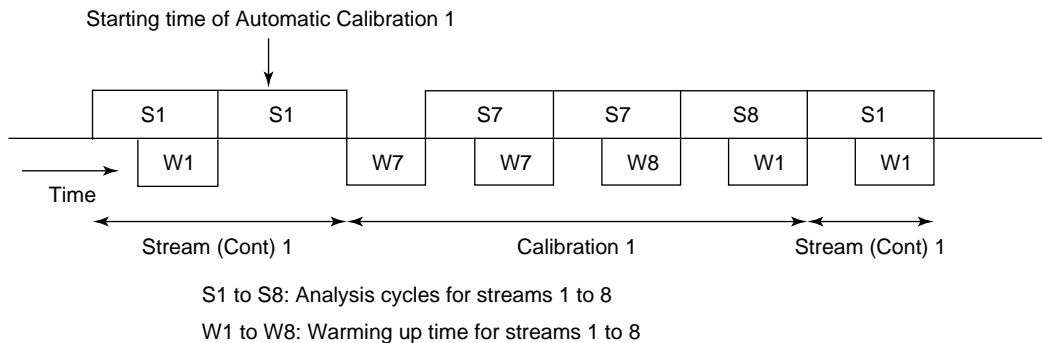

F0414.EPS

Figure 4.14 Action of Automatic Calibration (2)

• Semiautomatic Calibration

The same action is performed when the calibration is specified at any timing during analysis.

- (1) An action when Calibration 1 is specified while the measurement status is in Stream Sequence 1 and the operation mode is in Run, is shown in Figure 4.15.

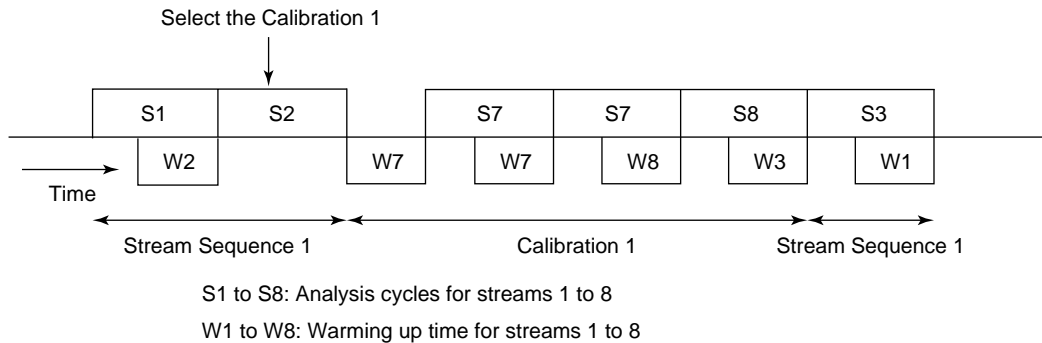

F0415.EPS

Figure 4.15 Action of Semiautomatic Calibration (1)

- (2) An action when calibration 1 is specified while the measurement status is in Stream (continuous) 1 and the operation mode is in Run, is shown in Figure 4.16.

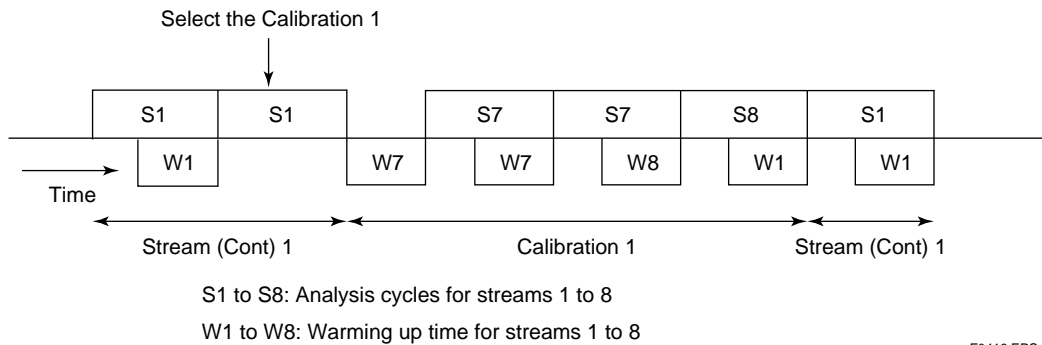

F0416.EPS

Figure 4.16 Action of Semiautomatic Calibration (2)

- (3) When Calibration 1 is specified while the measurement status is in Stream Sequence 1 to 4 or in Stream (continuous) 1 to 31 and the operation mode is in Stop or in Pause, the measurement status is immediately changed to Calibration 1 and then Calibration 1 is performed. After Calibration 1 has been completed, the previous measurement status is retrieved and the operation mode turns to Stop. The same action is performed when Calibration 1 or 2 is specified.

• Manual Calibration

The same action is performed when the calibration is specified at any timing during analysis.

- (1) An action when Calibration 1 is specified while the measurement status is in Stream Sequence 1 and the operation mode is in Run, is shown in Figure 4.17. After Calibration 1 has been completed, the measurement status returns to Stream Sequence 1 and the operation mode turns to Stop.

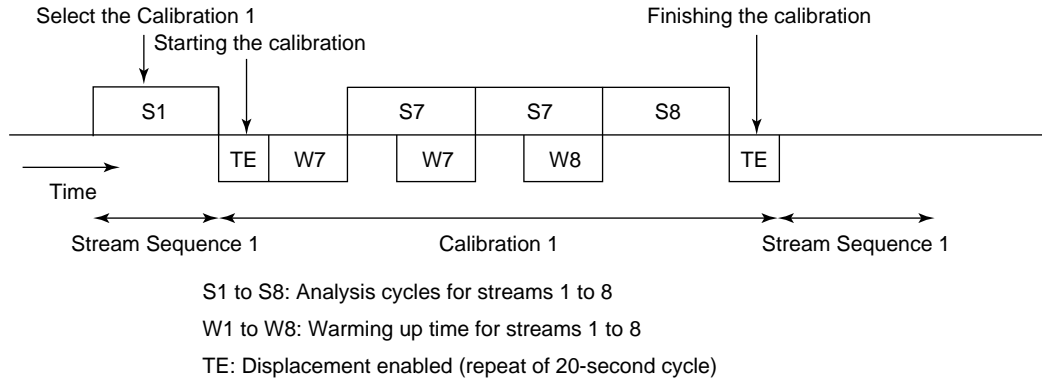

F0417.EPS

Figure 4.17 Action of Manual Calibration (1)

- (2) An action when Calibration 1 is specified while the measurement status is in Stream Sequence (continuous) 1 and the operation mode is in Run, is shown in Figure 4.18. After Calibration 1 has been completed, the measurement status returns to Stream (continuous) 1 and the operation mode turns to Stop.

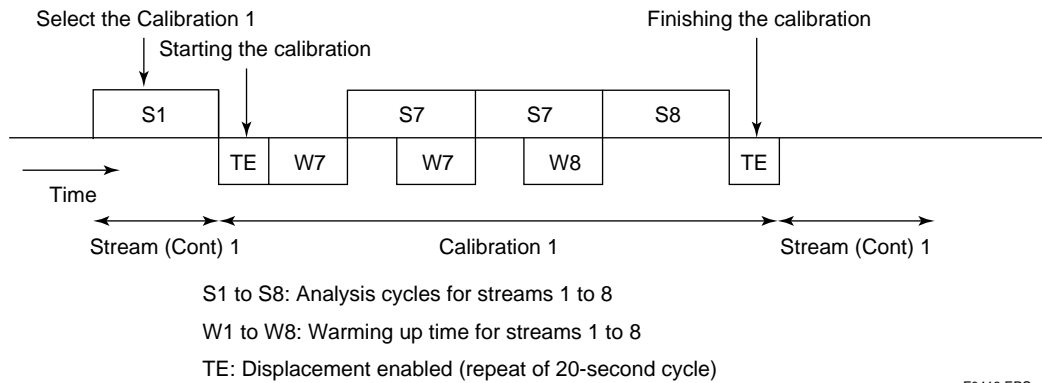

F0418.EPS

Figure 4.18 Action of Manual Calibration (2)

- (3) When calibration 1 is specified while the measurement status is in Stream Sequence 1 to 4 or in Stream (continuous) 1 to 31 and the operation mode is in Stop or in Pause, displacement become available immediately. The following actions are the same as those described in (1) or (2). Refer to the action after the start of calibration in Figure 4.17 or Figure 4.18. The same action is performed when Calibration 2 or 3 is specified.

4.4.5 Actions of Validation

Validation 1 to 3 is allowed to be specified only when the measurement status is in Stream Sequence 1 to 4 or in Stream (continuous) 1 to 31. Actions are different according to settings. The same action is performed when the starting time comes at any timing during analysis.

• Automatic Validation

- (1) An action when the starting time of Automatic Validation 1 comes while the measurement status is in Stream Sequence 1 and the operation mode is in Run, is shown in Figure 4.19.

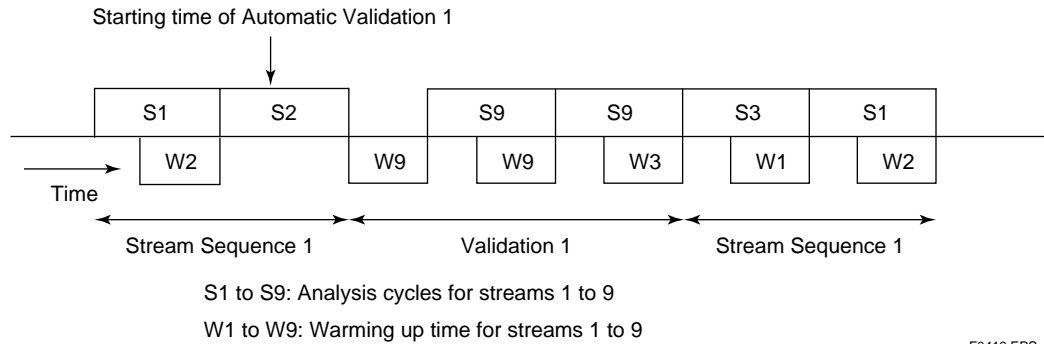

Figure 4.19 Action of Automatic Validation (1)

- (2) An action when the starting time of Automatic Validation 1 comes while the measurement status is in Stream (continuous) 1 and the operation mode is in Run, is shown in Figure 4.20.

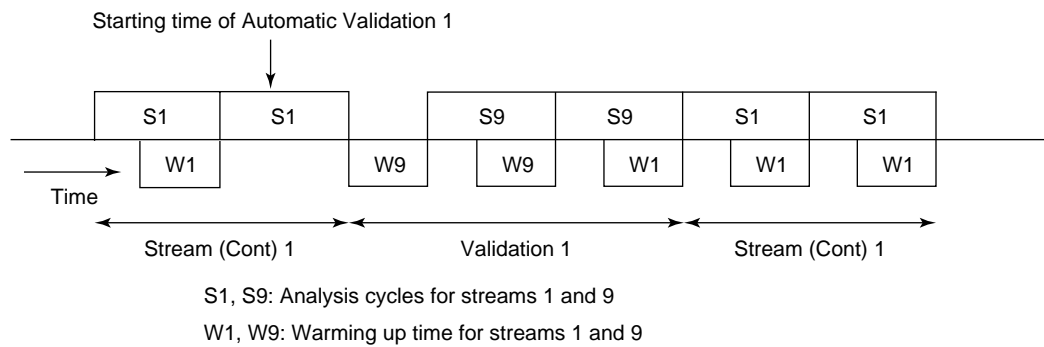
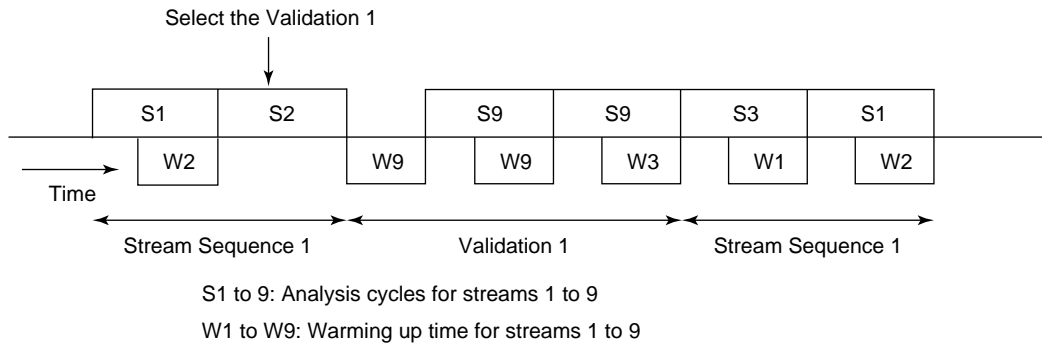

Figure 4.20 Action of Automatic Validation (2)

• Semiautomatic Validation

The same action is performed when the validation is specified at any timing during analysis.

- (1) An action when Validation 1 is specified while the measurement status is in Stream Sequence 1 and the operation mode is in Run, is shown in Figure 4.21.



F0421.EPS

Figure 4.21 Action of Semiautomatic Validation (1)

- (2) An action when Validation 1 is specified while the measurement status is in Stream (continuous) 1 and the operation mode is in Run, is shown in Figure 4.22.

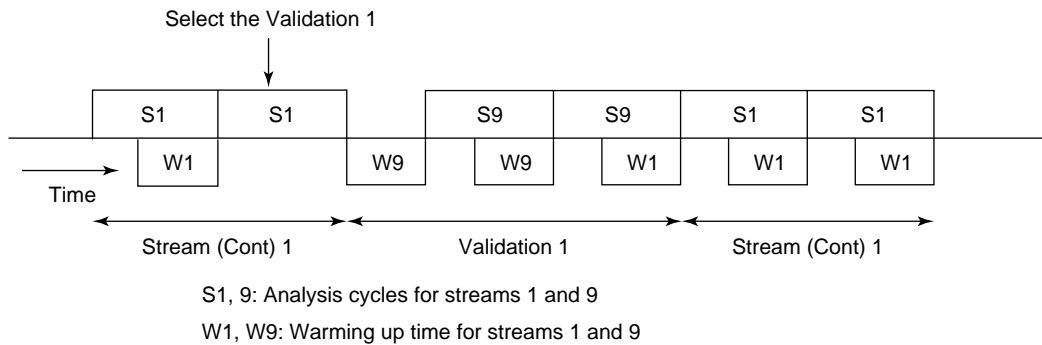

F0422.EPS

Figure 4.22 Action of Semiautomatic Validation (2)

- (3) When Validation 1 is specified while the measurement status is in Stream Sequence 1 to 4 or in Stream (continuous) 1 to 31 and the operation mode is in Stop or in Pause, the measurement status is immediately changed to Validation 1 and then Validation 1 is performed. After Validation 1 has been completed, the previous measurement status is retrieved and the operation mode turns to Stop. The same action is performed when Validation 2 or 3 is specified.

• Manual Validation

The same action is performed when the validation is specified at any timing during analysis.

- (1) An action when Validation 1 is specified while the measurement status is in Stream Sequence 1 and the operation mode is in Run, is shown in Figure 4.23. After Validation 1 has been completed, the measurement status returns to Stream Sequence 1 and the operation mode turns to Stop.

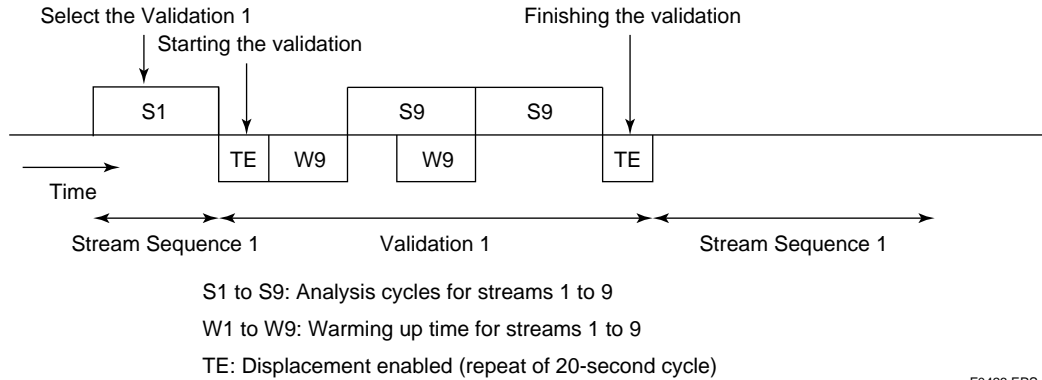

Figure 4.23 Action of Manual Validation (1)

- (2) An action when Validation 1 is specified while the measurement status is in Stream (continuous) 1 and the operation mode is in Run, is shown in Figure 4.24. After Validation 1 has been completed, the measurement status returns to stream (continuous) 1 and the operation mode turns to Stop.

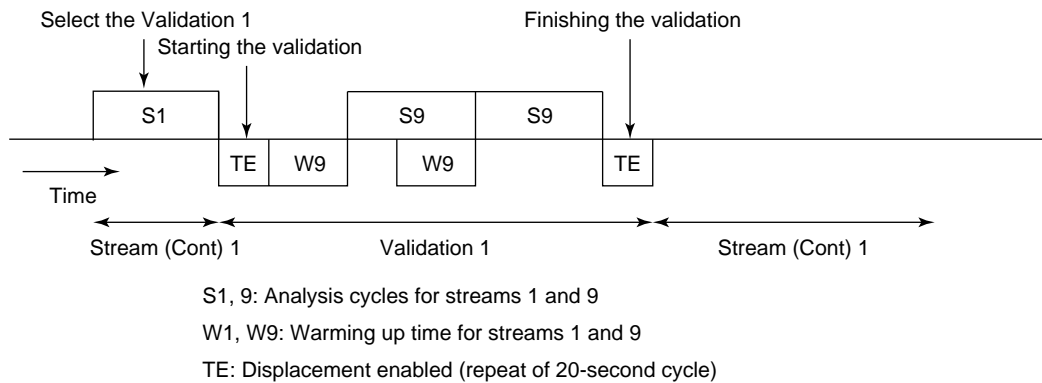

Figure 4.24 Action of Manual Validation (2)

- (3) When Validation 1 is specified while the measurement status is in Stream Sequence 1 to 4 or in Stream (continuous) 1 to 31 and the operation mode is in Stop or in Pause, displacement become available immediately. The following actions are the same as those described in (1) or (2). Refer to the action after the start of validation in Figure 4.23 or Figure 4.24. The same action is performed when Validation 2 or 3 is specified.

4.5 Computation and Processing

The following are processed using chromatograms obtained as detection signals. For the setting procedure, see the LCD Panel Operation Manual, IM 11B03A03-05E.

- Peak processing
- Deviation processing
- Additional processing
- Signal processing

Each processing is outlined below. For details, see the Technical Guide, IM 11B03A03-03E.

4.5.1 Peak Processing

This processing detects peaks from a detector signal and determines the concentrations of components based on the area or height of each peak. The retention times, peak half-width and so on are also determined from the detected peaks.

4.5.2 Deviation processing

This processing determines the value obtained by subtracting the sum of the concentrations of components computed by peak processing from the total sum of set concentrations.

4.5.3 Additional processing

There are the following three types of processing in the additional processing:

- Linear computation processing

This processing determines the total sum of the concentrations of each component computed in the peak processing multiplied by individual coefficients.

- Ratio computation processing

This processing determines the ratio of concentrations of two components obtained by the peak processing.

- Separation capability processing

This processing determines the separation capability using retention time and peak half-widths of two adjacent components determined by the peak processing.

4.5.4 Signal Processing

There are three types of processing in the signal processing:

- Base level processing

The detector signal at a time set for base level processing within the analysis cycle avoiding component signals is used as the base level value. If the base level processing is not set, the detector signal immediately after the start of analysis is employed as the base level value.

- Signal level processing

The differences between the detector signals at each time set for signal level processing within the analysis cycle and the base level value, are used as the signal level values. If more than one base level processing is set, the base level value immediately before a base level processing is used for signal level processing.

- Noise level processing

Among the preceding 20 data for detector signals at a time set for noise level processing within the analysis cycle, the maximum and minimum values are used as noise level values.

4.6 Alarm Processing

There are four alarm levels. For details of alarms, see the Alarm Message Manual, IM 11B03A03-06E.

- Level 1

Alarms for system or hardware failures. When an alarm is generated, the alarm condition is maintained until it is reset.

If a level-1 alarm is generated in the Run or Lab mode, the operation mode changes to Stop at the end of the measurement being executed.

- Level 2

Alarms for measuring conditions failure.

When an alarm is generated, the alarm condition is maintained until it is reset.

- Component

Alarms when measurement results such as concentrations and retention times become out of each specified range.

If an alarm is generated, the alarm condition is maintained until it is reset.

- Level 3

Alarms for minor failures or information other than level-1 and level-2 alarms.

The alarm condition is not maintained.

5. Actions of External Input and Output Signals

5.1 Analog Hold Output

Up to 36 outputs are available as option.

Actions of analog hold output are different between when the actual stream is specified and when "99" is specified for the stream number in setting analog hold output. Actions of contact output are different whether a contact output is used or not as a stream identification signal. The following explains actions of analog output as well as contact output. If "99" is specified for the stream number, contact output must be used as a stream identification signal. For actions of contact output other than stream identification signals, refer to Section 5.2, "Contact Output."

5.1.1 When Actual Stream is Specified for Stream Number (without Stream Identification Signal)

An action when analog hold output is specified as shown in Table 5.1, is illustrated in Figure 5.1.

Table 5.1 Setting of Analog Output

	Output stream #1	Output peak #1	Output stream #2	Output peak #2
CH.1	1	1	None	None
CH.2	1	2	None	None
CH.3	1	3	None	None
CH.4	1	4	None	None
CH.5	2	1	None	None
CH.6	2	2	None	None
CH.7	2	3	None	None
CH.8	2	4	None	None

T0501.EPS

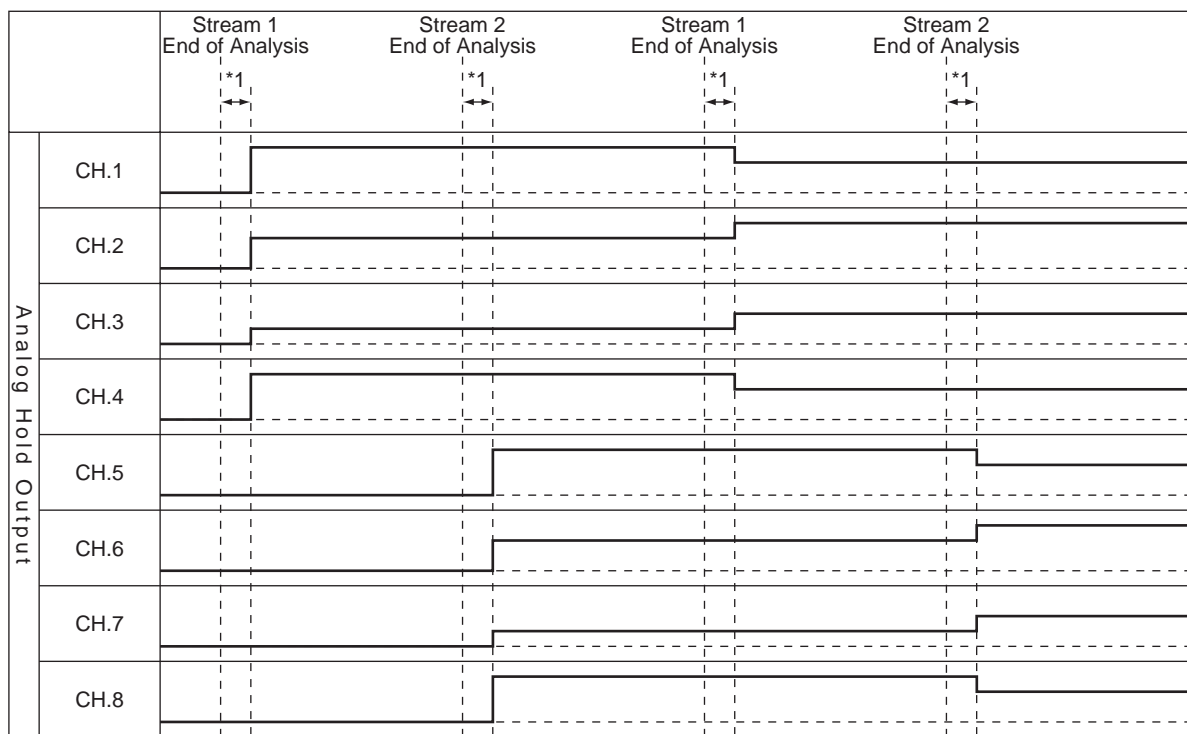

End of Analysis: Time when the final peak detection is completed or peak detection stop time.

*1: One to two seconds (depending on analysis specifications)

F0501.EPS

Figure 5.1 Action of Analog Output

5.1.2 When Actual Stream is Specified for Stream Number (with Stream Identification Signal)

An action when analog hold output is specified as shown in Table 5.2, is illustrated in Figure 5.2.

Table 5.2 Setting of Analog Output

	Output stream #1	Output peak #1	Output stream #2	Output peak #2
CH.1	1	1	2	1
CH.2	1	2	2	2
CH.3	1	3	2	3
CH.4	1	4	2	4

T0502.EPS

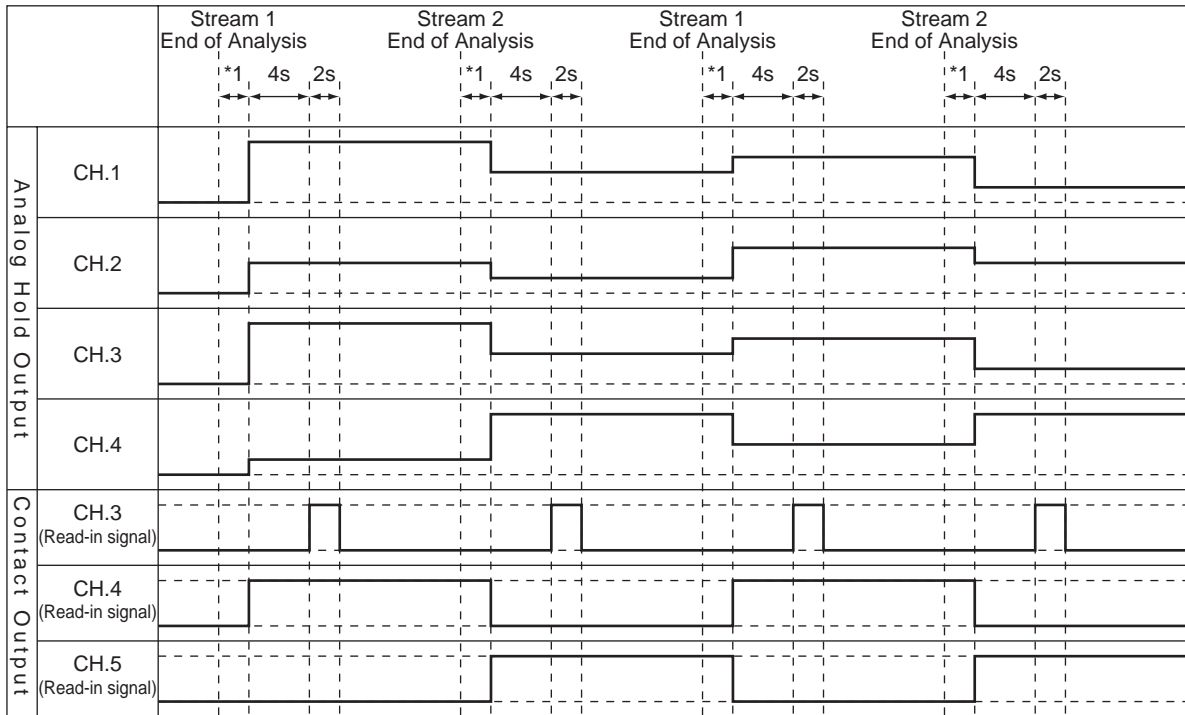

End of Analysis: Time when the final peak detection is completed or peak detection stop time.

*1: One to two seconds (depending on analysis specifications)

F0502.EPS

Figure 5.2 Actions of Analog Output and Contact Output

5.1.3 When "99" is Specified for Stream Number (with Stream Identification Signal)

An action when analog hold output is specified as shown in Table 5.4 under the peak setting conditions of each stream as shown in Table 5.3, is illustrated in Figure 5.3.

Table 5.3 Conditions of Peaks for Streams

	Stream 1	Stream 2	Stream 3
Peak 1	Exist	Exist	Exist
Peak 2	Exist	None	Exist
Peak 3	Exist	Exist	None
Peak 4	Exist	None	Exist

T0503.EPS

Table 5.4 Setting of Analog Output

	Output stream #1	Output peak #1	Output stream #2	Output peak #2
CH.1	99	1	None	None
CH.2	99	2	None	None
CH.3	99	3	None	None
CH.4	99	4	None	None

T0504.EPS

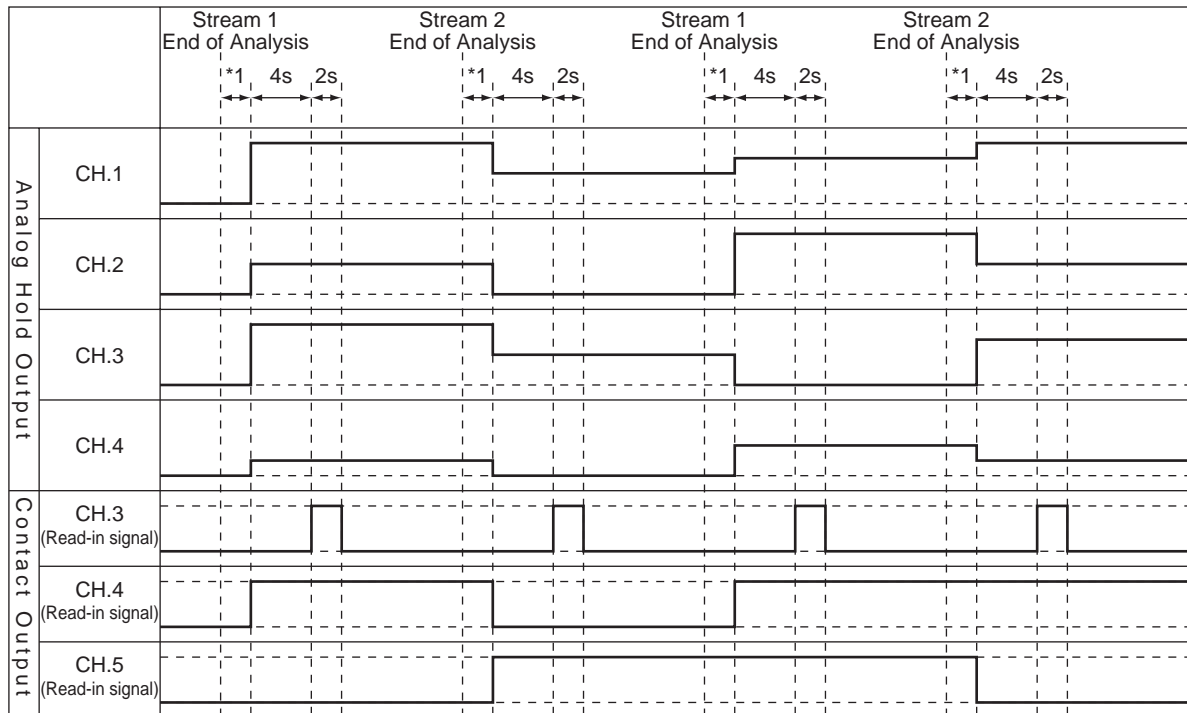

End of Analysis: Time when the final peak detection is completed or peak detection stop time.

*1: One to two seconds (depending on analysis specifications)

F0503.EPS

Figure 5.3 Actions of Analog Output and Contact Output

5.2 Contact Output

The following five types can be specified for up to eight contact outputs as standard.

- Stream Sequence
- Stream
- Operation Mode
- Alarm
- Timing

Actions when each type is specified, are described below.



CAUTION

If settings are changed in the DO Setup panel while the contact output is On, the contact output may remain unchanged in On until the power is turned off and on. In changing settings, make sure that the contact output is Off.

5.2.1 Stream Sequence

When the stream sequence with the number specified in the DO Setup panel runs, the contact output turns On.

Actions when Stream Sequence 1 is specified for Contact Output 1, are described below.

- (1) When the operation mode is changed from Stop to Run:
When the Warming up time for the first stream of Stream Sequence 1 starts, the contact output turns On.
- (2) When the operation mode is changed from Run to Stop:
The contact output is kept On until the measurement status is changed next.
- (3) When the operation mode is changed from Run to Pause:
The contact output is kept On.
- (4) When Stream Sequence is changed from 1 to 2:
When the Warming up time for the first stream of Stream Sequence 2 starts, the contact output turns Off.
- (5) When Stream Sequence is changed from 2 to 1:
When the Warming up time for the first stream of Stream Sequence 1 starts, the contact output turns On.
- (6) When Stream Sequence 1 is changed to other measurement status:
When the Warming up time for the first stream of the other measurement status starts, the contact output turns Off.

5.2.2 Stream

When the stream with the number specified in the DO Setup panel runs, the contact output turns On.

Actions when Stream 1 is specified for Contact Output 1, are described below.

- (1) When the operation mode is changed from Stop to Run:
When the Warming up time of Stream 1 starts, the contact output turns On.
- (2) When the operation mode is changed from Run to Stop:
The contact output is kept On until the measurement status is changed next.
- (3) When the operation mode is changed from Run to Pause:
The contact output is kept On.
- (4) When Stream (continuous) is changed from 1 to 2:
When the analysis of Stream 2 starts, the contact output turns Off.
- (5) When Stream (continuous) is changed from 2 to 1:
When the analysis of Stream 1 starts, the contact output turns On.
- (6) When Stream (continuous) 1 is changed to other measurement status:
When the Warming up time for the first stream of the other measurement status starts, the contact output turns Off.

5.2.3 Operation Mode

When the operation mode specified in the DO Setup panel is enabled, the contact output turns On. If Run is specified, the start of the Warming up time triggers the contact output to turn On.

5.2.4 Alarm

If an alarm specified in the DO Setup panel is generated, the contact output turns On. When the alarm is cleared, the contact output turns Off.

5.2.5 Timing

The contact output turns on and off according to the timing specified in the Method Setup panel.

5.3 Contact Input

The following six types can be specified for up to eight contact inputs as standard.

- Stream Sequence command
- Stream (continuous) command
- Stream (1 cycle) command
- Calibration (Validation)
- Operation Mode
- Alarm processing



CAUTION

Contact input requires closed, pulse input. For input, closed, pulse input for at least 2 seconds must be performed. Closed, pulse input for less than 2 seconds may result in invalid function. Status input must not be performed.

For actions other than alarm processing, refer to Section 4.4, "Description of Actions."

When alarm processing is specified for contact input, the alarm specified in the DI Setup panel is generated.

5.4 Communication Input and Output

5.4.1 GC6 Type Output Data Format (Fixed to 45 Characters)

(1) Analysis value data (component concentration)

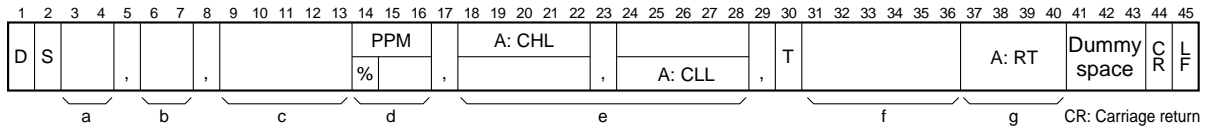

a: Stream number (01 to 24) b: Component number (01 to 24) c: Component concentration (without zero suppression)
 e: Concentration error alarm (Upper limit = A:CHL, Lower limit = A:CLL) f: Retention time (seconds) g: Retention time error alarm
 Note: The error alarm is output only if an error occurs. (Dummy space if no error occurs)

F0504.EPS

(2) Analysis value data (component ratio operation, linear polynomial operation)

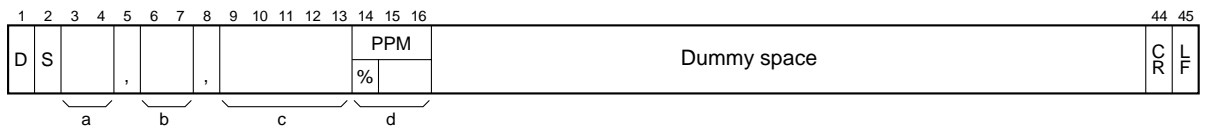

a: Stream number (01 to 24) b: Component number (01 to 24) c: Operation value (without zero suppression) d: Unit

F0505.EPS

(3) Calibration factor

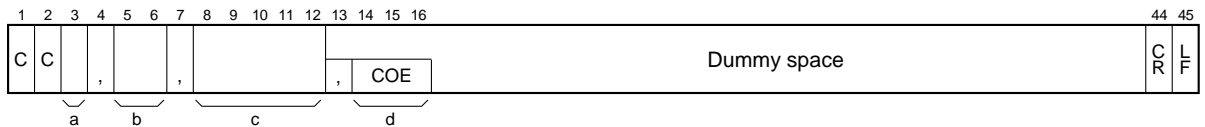

a: Standard sample (STD1=1, STD2=2) b: Component number (01 to 24) c: Calibration factor (without zero suppression)
 d: Calibration factor error (only if an error occurs)

F0506.EPS

(4) Error alarm

- Memory pattern check error
- Calibration out of range
- Isothermal oven temperature error
- Pressure switch 1 (or 2) OFF
- Communication error
- Calibration repeatability error
- Watchdog timer
- Detector 1 (or 2) calibration error
- Power off
- External contact inputs 1 to 8
- FID1 (or 2) extinguished

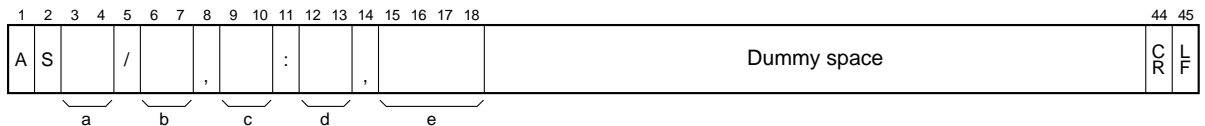

a: Month, b: Day, c: Hour, d: Minute e: Error alarm types

- MEM: Memory pattern check error
- WDT: Watchdog timer
- AD1: Detector 1 calibration error
- AD2: Detector 2 calibration error
- TMPH: Isothermal oven temperature error
- CAR1: Pressure switch 1 OFF
- CAR2: Pressure switch 2 OFF

Note: For 3 characters, the 18th character is a dummy space.

- EXT1: External contact input 1
- EXT2: External contact input 2
- ...
- EXT8: External contact input 8
- FLM1: FID1 extinguished
- FLM2: FID2 extinguished
- RPT: Calibration repeatability error
- CAL: Calibration out of range
- POF: Power off
- NSD: Communication error (GC1000 - GCCU)

} 8 items in total

F0507.EPS

5.4.2 GC6Type Input Data Format

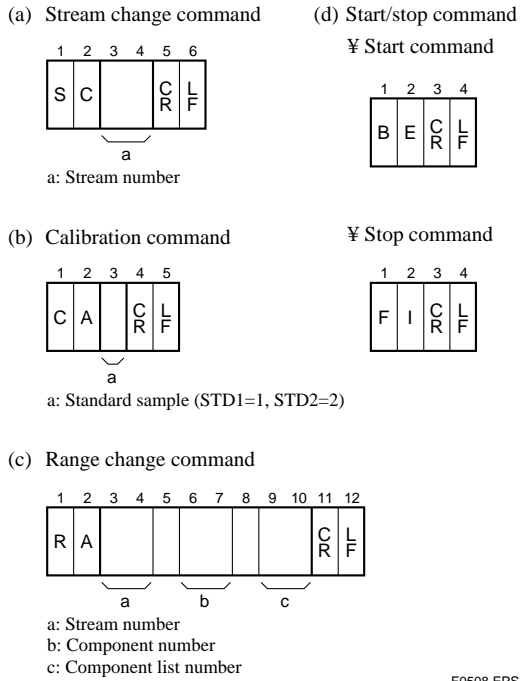

F0508.EPS

Non-protocol output signal transmission timing

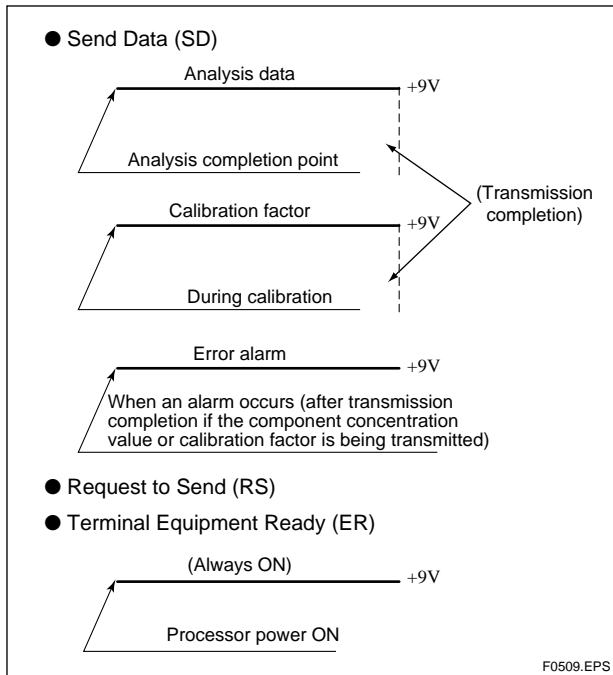

F0509.EPS

I/O instruction format and communication control procedure for handshaking

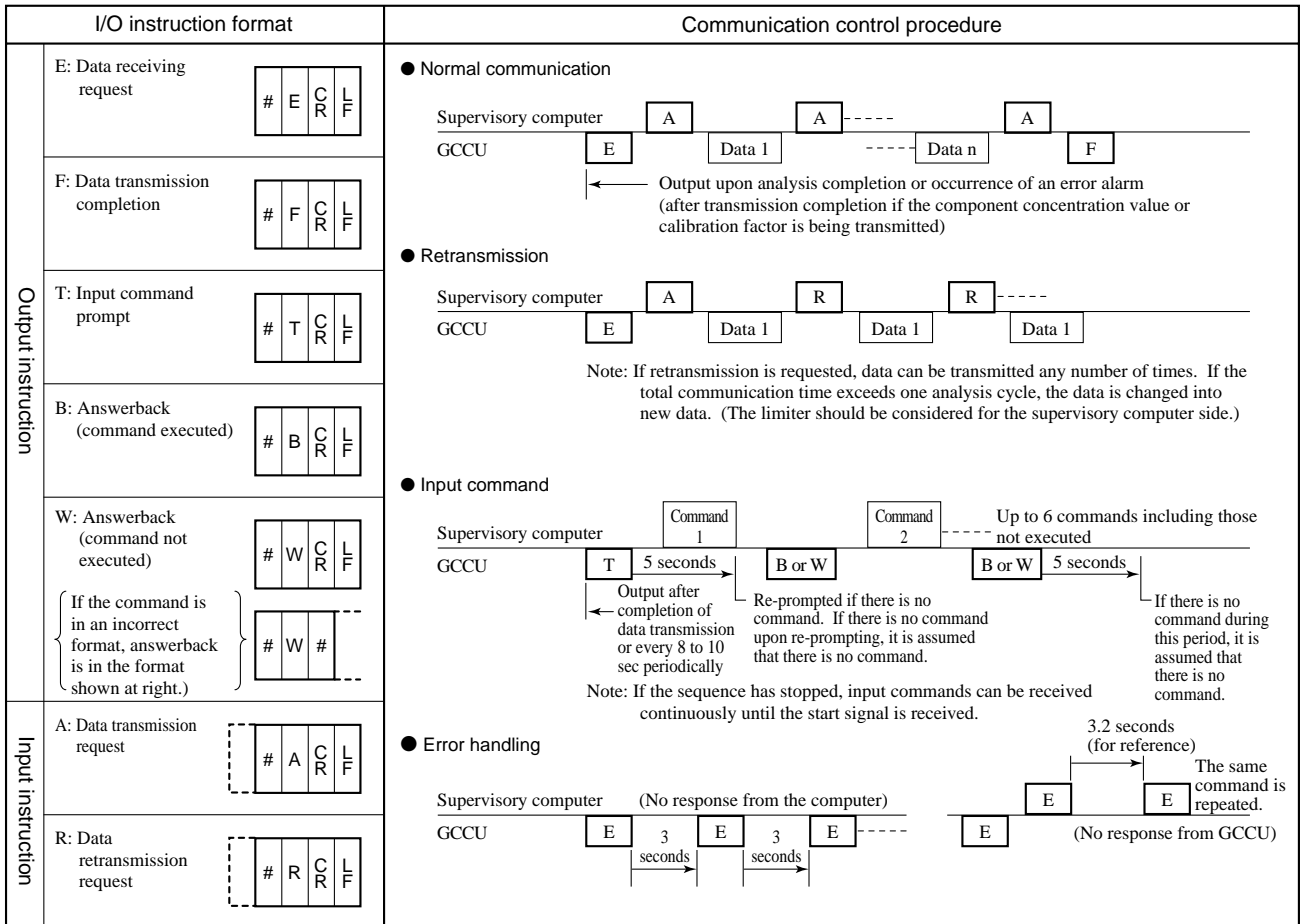

F0510.EPS

5.4.4 GC8/GC1000 Type Input Data Format

(a) Stream change command

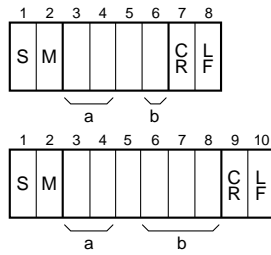

a: Stream number
b: Analyzer number (1 to 6) or (001 to 255)

(b) Calibration command

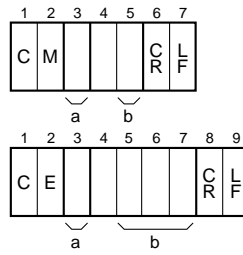

a: Standard sample (STD1=1, STD2=2, STD3=3)
b: Analyzer number (1 to 6) or (001 to 255)

(c) Range change command

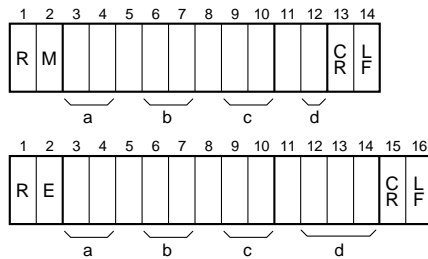

a: Stream number
b: Component number
c: Component list number
d: Analyzer number (1 to 6) or (001 to 255)

(d) Start/stop command

¥ Start command

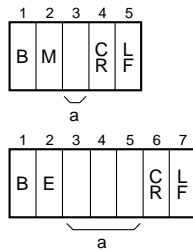

a: Analyzer number (1 to 6) or (001 to 255)

¥ Stop command

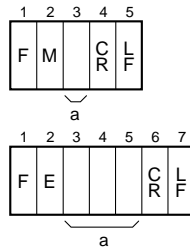

a: Analyzer number (1 to 6) or (001 to 255)

F0515.EPS

Non-protocol output signal transmission timing

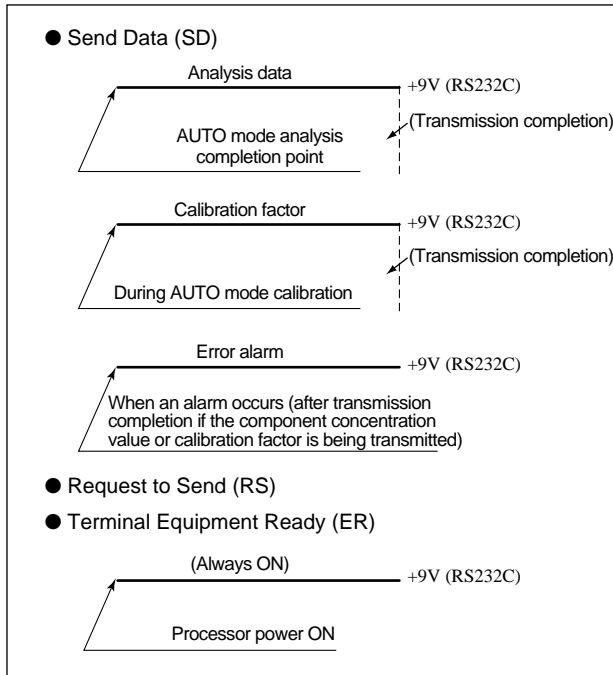

F0516.EPS

I/O instruction format and communication control procedure for handshaking

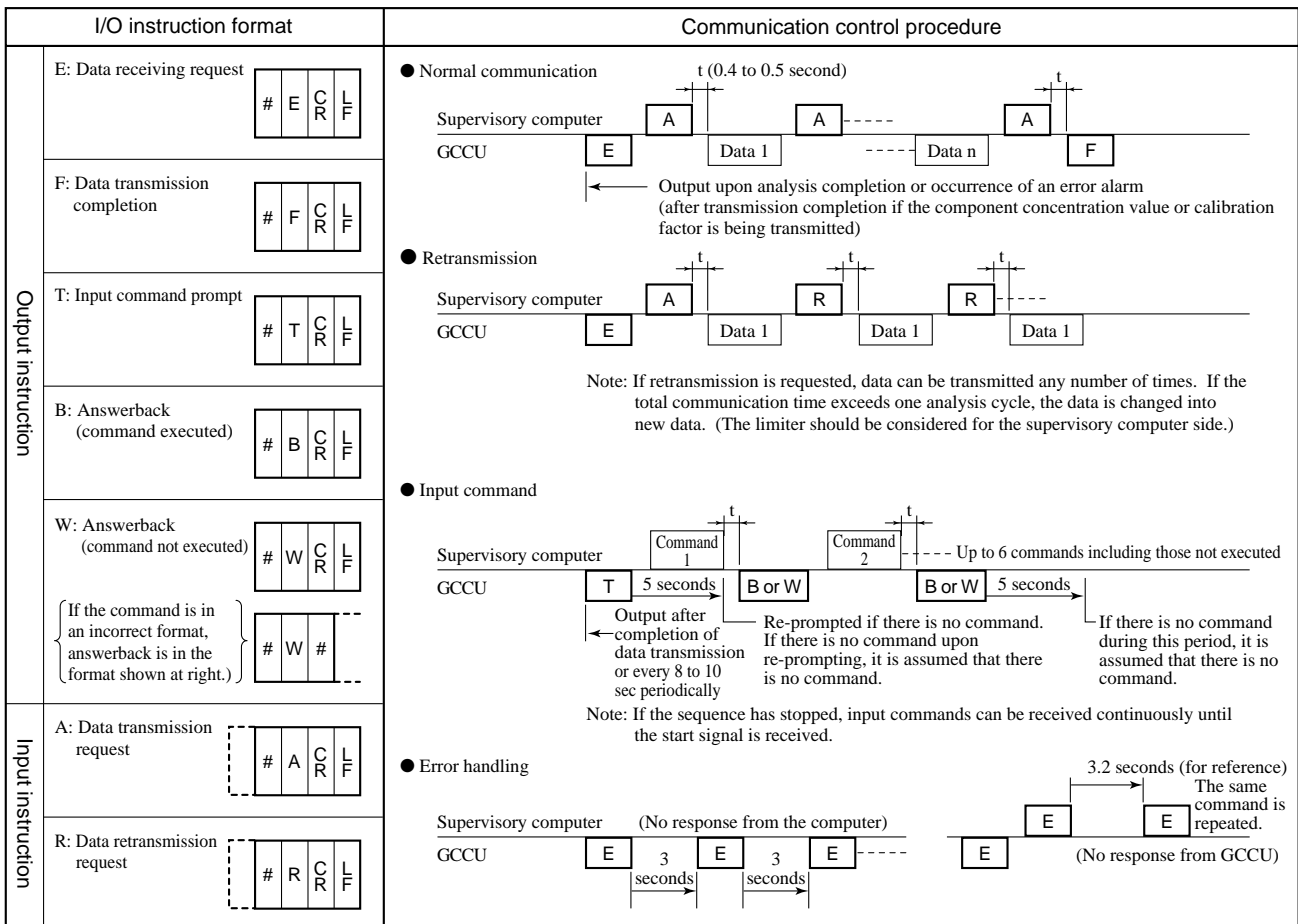

F0517.EPS

Note: If #ACRLF or #RCRLF is not received in 20 seconds or more after the data has been sent, the transmission of the analysis data of that cycle will be aborted.

5.4.5 MODBUS Communication Data Specification

(1) Coil (Command Contact)

(1) Run command

Commands the start of continuous analysis to the GC1000 Mark II.

(2) Stop command

Commands the stop of continuous analysis to the GC1000 Mark II.

(3) Time setting request

Requests the GC1000 Mark II to set the device clock to values in addresses 40001-40004. Before this request, time should be set by a holding register.

(4) Stream Sequence setting command

Commands the GC1000 Mark II to perform the specified stream sequence. This command is rejected if the measurement status is in Calibration/Validation, including wait status, or in Stream (1 cycle), including wait status.

(5) Calibration/Validation command

Commands the GC1000 Mark II to perform the specified calibration or validation. Corresponding numbers to the Calibration/Validation numbers to be specified are as follows:

Calibration 1 to 3: 1 to 3

Validation 1 to 3: 4 to 6

This command is rejected if the measurement status is in Stream (1 cycle), including wait status, or the calibration method is set to Automatic/Manual.

(6) Stream (continuous) setting command

Commands the GC1000 Mark II to perform a continuous measurement of the specified stream. This command is rejected if the measurement status is in Calibration/Validation, including wait status, or in Stream (1 cycle), including wait status.

Note 1: Coils are automatically reset from 1 to 0 when the slave accepts the message.

Note 2: Pattern requests are queued when received but may not activate immediately.

Note 3: Input relays should be monitored to determine when commands actually activate.

Note 4: When the master sends multiple commands to the slave simultaneously, the slave executes it in the order received regardless of the content of the commands.

(2) Input Relay (Status Contact)

- (1) Analyzer normal
The GC1000 Mark II is normal. A 1 is displayed if there is no active level 1 (critical failure) or level 2 (minor failure) alarm.
- (2) Analyzer error
The GC1000 Mark II is faulty. A 1 is displayed if there is at least one active level 1 (critical failure) alarm.
- (3) Alarm status change
A 1 is displayed when a new alarm occurs on the GC1000 Mark II. After this status is read and when at least one alarm status is read, this bit is automatically reset to 0.
- (4) Measuring (Run mode)
The GC1000 Mark II is analyzing. A 1 is displayed when it is in Run mode. Otherwise, 0 is displayed.
- (5) Stop (Stop mode)
The GC1000 Mark II is not analyzing. A 1 is displayed when it is in Stop mode. Otherwise, 0 is displayed.
- (6) Maintenance (other modes)
If the GC1000 Mark II is in Manual, Lab, or Pause mode, a 1 is displayed. Otherwise, 0 is displayed.
- (7) Data update
New analysis data is now available from the GC1000 Mark II. Data update is automatically reset to 0 once data update is read and at least one analysis value is read.
- (8) Data valid
Data is valid for a particular peak on the GC1000 Mark II. For analysis peaks, the analysis value must be between the upper and lower limits and the retention time is at or below the upper limit. For operation peaks, the data to be used for operation is valid. A 1 is displayed when data is valid.
- (9) Alarm status
The alarm status of the GC1000 Mark II is displayed for each alarm number. If an alarm occurs, 1 is displayed. Otherwise, 0 is displayed. The alarm number is 1 to 99 for level 1 alarms of the GC1000 Mark II, and 101 to 199 for level 2 alarms of the GC1000 Mark II.
- (10) Calibration factor update
The GC1000 Mark II has new calibration factors for a particular stream. The address is reset to 0 after the calibration factor update is read and when at least one calibration factor is read.
- (11) Executing the Stream Sequence
The corresponding stream sequence on the GC1000 Mark II is being executed.
- (12) Measurement status command failure
If the command is not executed after any of the Stream (continuous) setting command, Calibration/Validation command, Stream Sequence setting command has been sent by the coil, 1 is displayed. When the command is executed after the next command has been sent, this bit is reset.

(3) Holding Register (Set Data)

(1) Time setting value

This is a set of four registers used by the DCS to set the device clock. When the time setting request coil (address 00003 for GC1000 Mark II and GCIU, 00001 for the analyzer server) is activated, these entries are used for the year, month/day, hour and minute/second. Since all devices on the highway synchronize to the analyzer server clock on a regular basis, the analyzer server clock should be regularly set.

Example : September 25, 1996, 15:23:10

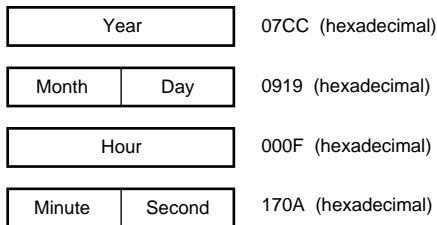

F0518.EPS

Figure 5.4 Time Register Configuration

(2) Range setting command

This address allows the range of the component indicated by the specified stream number and peak number to be changed on the GC1000 Mark II.

(3) Analysis value

These addresses display the same data as the analysis value in the input register, however values cannot be written to these addresses. Only these addresses support real number (floating point) form.

(4) Input Register (Measured Data)

(1) Stream number

The currently active stream number on the GC1000 Mark II is displayed. In Stop or Manual mode, the stream number is 0. In Lab mode, the stream number is 32.

(2) Starting peak number

The starting peak number assigned to each stream on the GC1000 Mark II is displayed. The maximum number of analysis values, including peaks of all streams, is 255. The number is 0 if no peak is assigned.

(3) Peak number

Peak number assigned to each stream on the GC1000 Mark II is displayed. See the Figure 5.5 below.

Example: the peak number of Stream 2, Peak 3 is 7.

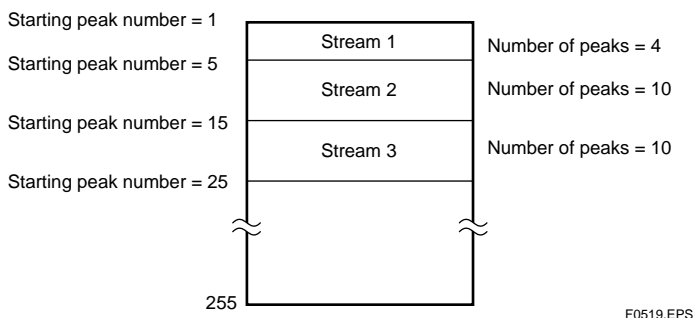
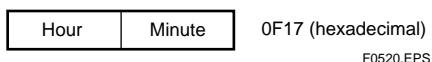

Figure 5.5 Example of Peak Allocation

(4) Sampling time

This register contains the latest sampling time for each stream on the GC1000 Mark II. Hour and minutes are stored.

Example : 15:23



(5) Analysis value

This register contains each analysis value. The value is represented by a fraction to the full scale or by a real number (floating point format). The full scale is set in advance for each analysis value and the scaling factor is user selectable as either 9999 or 65535. The real number format conforms to the IEEE standard and requires two registers per peak.

The fraction format is calculated as follows:

$$(\text{Analysis value} \times \text{Scaling factor}) / \text{Full scale value}$$

For example, if the analysis result is 5 ppm and the range is 0-20 ppm, the value read using a scaling factor of 9999 is

$$\frac{5}{20} \times 9999 = 2499 \text{ (09C3)}$$

F0521.EPS

For the real number format, units such as % and ppm are considered. For example, the real number value converted from 1.5 is directly transmitted as 1.5%. The GC1000 Mark II updates analysis values at the end of each cycle. The GCIU updates the average values according to the user set scan interval.

(6) Retention time

This register contains the retention time for each measured stream of the GC1000 Mark II. The unit is in seconds.

(7) Calibration factor

This register contains the calibration factor for each calibrated stream of the GC1000 Mark II. Since the factors are in the range of 0.000 to 9.999, each value is multiplied by 1000 and displayed as integers, i.e., 0000 to 9999.

Table 5.5 Address Table (GC1000)

Name	Address	Description
Run command	00001	Received the message by the master, the slave reset.
Stop command	00002	Same as above
Time setting request	00003	Same as above
Stream sequence select command	0001P	Same as above P: Stream Sequence number (1 to 4)
Calibration (validation) command	0002P	Same as above P: 1 to 3 (Cal. 1 to 3), 4 to 6 (Val. 1 to 3)
Stream (Cont) select command	001TT	TT: Stream number (01 to 31)
Analyzer normal	10001	
Analyzer error	10002	
Analyzer status change	10003	Reset when the alarm status is read after alarm status change is read.
Measuring	10004	
Stop	10005	
Maintenance	10006	
Stream sequence	1001P	P: Stream Sequence number (1 to 4)
Stream (Cont)	10021	
Calibration (Validation)	10022	
Stream sequence	10023	
Data update	101TT	Reset when the analysis value is read after data update is read. (TT: Stream number)
Calibration factor update	102TT	Reset when the calibration factor is read after calibration factor update is read. (TT: Stream number)
Data valid	11CCC	CCC: Component number
Alarm status	12AAA	AAA: Alarm number (001 to 249)
Time setting request	40001 to 40004	Year (40001), month/day (40002), hour (40003), minute/second (40004)
Analysis value	41DDD	Read only (Write disabled) DDD(real format)5CCC*2-1(CCC: Component number)
Range select	4NNQQ	NN: Stream number +40, QQ: Peak number
Stream number	30001	
Starting peak number	301TT	Starting peak number of each stream (TT: Stream number)
Peak number	302TT	Peak number of each stream (TT: Stream number)
Sampling time	303TT	Hour/Minute (TT: Stream number)
Analysis value	31CCC/ 31DDD	Analysis value (CCC: component number) DDD(real format): CCC*2-1(CCC: Peak number)
Retention time	32CCC	Seconds
Calibration factor	33CCC	Analysis value (CCC: component number)

T0505.EPS

◆ Revision Record

- Manual No. : IM 11B03A03-01E
- Title : GC1000 Mark II Process Gas Chromatograph Overview

Oct. 2001/1st Edition

Newly published

July. 2002/2nd Edition

Introduction modified below;

Added “(5) When touching LCD Panel switches” to “WARNING”;

Corrected a part of “CENELEC (ATEX directive) certification”;

Corrected a part of “Installation site and environment”;

Added “Explanation for type Y purging” to “WARNING of explosionproof enclosure” of FM and CSA certification;

Corrected title of Sec. 3.3 (2);

Corrected title of Sec. 3.4 (2);

Aug. 2006/3rd Edition

Added the items for EPC and ethernet network (Page 2-2, 3-1, 3-2, 3-4 to 3-11, 4-8, 4-9)

Blank Page