

APPLICATION NOTE

vigilantplant.[®]
The clear path to operational excellence

Measuring the Electric Conductivity by use of Clean-in-place (CIP) System

Industry: Life Sciences, Chemical, Food and Beverage
Product: Inductive Conductivity Meters

Introduction

In the manufacturing process of Pharmaceutical, Chemical and Food & Beverage industries, the cleaning and sterilization of tanks and piping are done with various cleaning solutions, fresh or hot water and steam after manufacturing products. Clean- In-Place (CIP) is the system designed for automatic cleaning and disinfecting. The recovery of cleaning solutions contributes significantly to reduce chemical costs and wastewater processing costs.

Yokogawa ISC202 conductivity transmitter has earned a reputation in the recovery of cleaning solutions because it can take measurements with good boundary surface precision over a wide range.

Expected Benefits

- Optimizes cleaning and sterilizing application for tanks and piping by use of CIP
- Reduces operating costs

Process Overview

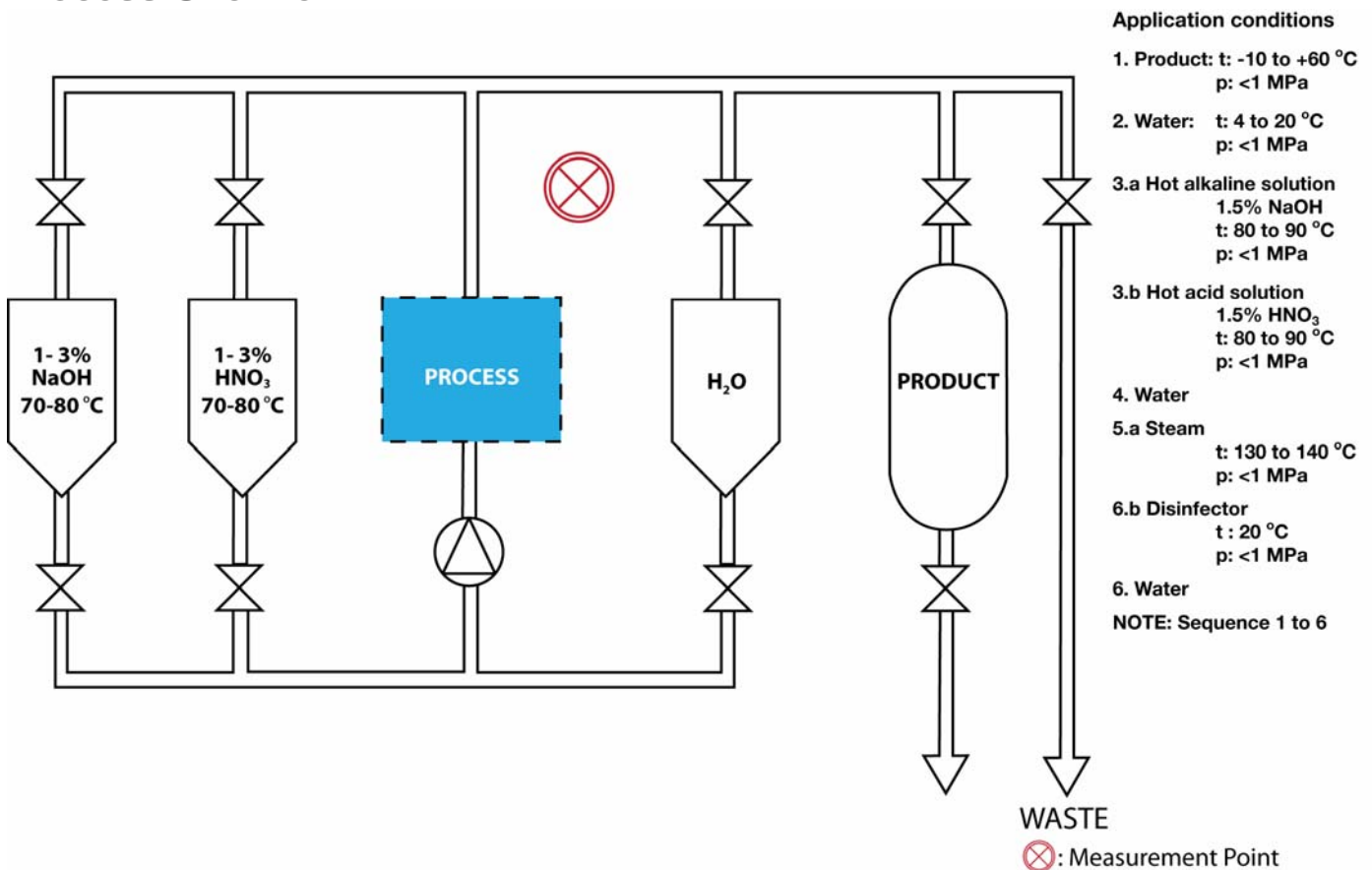

Solution Details

Measurement System
2-wire inductive conductivity system
Sensor
ISC40G
Flow-through type holder
ISC40FF
Transmitter
ISC202

Field Data

1. Process Conditions

	Concentration (%)	Temperature (°C)	Pressure MPa
Water	-	4 to 20	0 to 1
NaOH solution	1 to 5	80 to 90	0 to 1
HNO3 solution	1 to 5	80 to 90	0 to 1
Steam	-	below 130	0 to 1

2. Features of ISC Inductive Conductivity Meter used in a CIP Process

(1) Improved precision in boundary surface measurement.

(a) Equipped with a zero-suppression function according to output signal

* Zero suppression

Example: Output: 4 to 20 mA DC
Range: 100 to 300 mS/cm



zero-suppression function

(b) One sensor can handle a minimum span of 100µS/cm and a maximum span of 1999 mS/cm.

(2) Steam sterilization capability

Measurements can be performed at process solution temperatures of -10 to 130 °C and pressures no greater than 2 MPa {20 kgf/cm²}.