



**Monitoring pH at the Headbox**

**Industry:** Pulp and Paper  
**Product:** PH450

**Background Information**

Problems at the wet end of a paper machine can rarely be corrected down stream. That is why monitoring and controlling pH in pulp stock is critical to the paper making process. Essentially, at every stage in the manufacture of paper, correct pH values play a vital role. Variations in the pH value at the head box have a negative effect on the quality of the paper produced.

**Process**

The headbox physically prepares the pulp stock before it is converted into paper by the papermaking machine. It does so by smoothing out any outstanding variability in the pulp flow.

The front section of the headbox, called the stock distributor, receives the pulp stock flow from one or more inlet pipes and spreads it uniformly to a width equal to the final paper width. The central portion of the headbox dampens excessive pulp stock flow turbulences. Inlet cross flows from the stock distributor, corrects flow inequalities, and directs the stock into the slice (rear portion of headbox). The slice, which is located at the back of the head box, controls the

distribution of pulp stock onto the papermaking machine. The stock flows between a stationary lip and a movable lip to ensure an even velocity across the width of the machine to provide a constant, random fiber distribution.

The pH of the incoming wet stock to the headbox has a higher pH than desired, and therefore must be lowered. The pH of the pulp stock does not affect the final product quality as dramatically as it does in the bleaching process, but it is still important in achieving the desired printability of the paper. The stock is commonly controlled around 4.5 pH by adding alum or sulfuric acid upstream of the headbox; however the pH may be adjusted and controlled at whatever value is required to obtain optimum overall results.

Effective measurement and control of pH at the headbox requires equipment that can stand up to the abrasive components of the stock pulp. The headbox is the first wet end component of the paper machine and has high levels of suspended solids, making the pH measurement difficult because sensors are prone to clogging and fouling. This results in cleaning, calibration and possible replacement of electrodes.

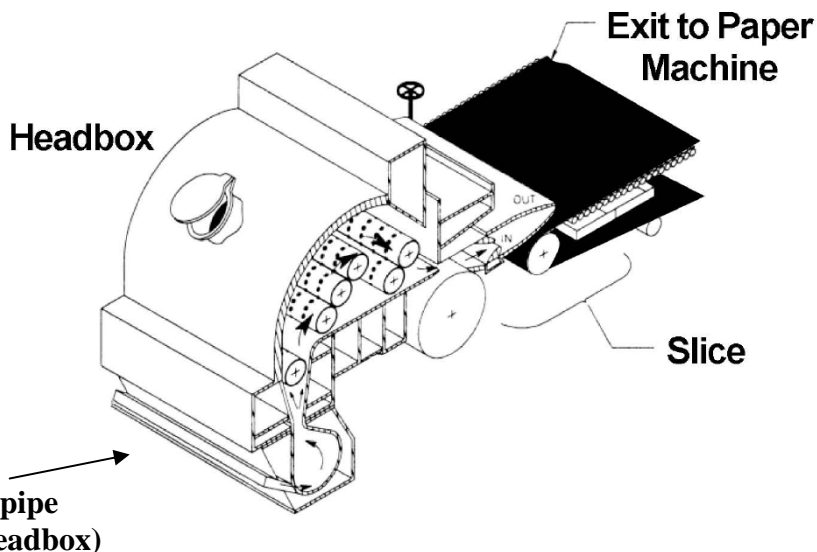

**Product**

## Recommendations

The headbox is the final place for pH control that can alter the pulp stock before it reaches the paper machine. Therefore, it is very important to have an accurate, reliable and continuous pH measurement.

Yokogawa has extensive experience dealing with the clogging and fouling problems that occur with pH measurements in paper mills. This has led us to select the Model PH97/DP sensor which has a solid state reference resistant to clogging and fouling. The PH97 is designed as a replaceable 4-1 sensor used in conjunction with the Model PH87 retractable assembly. The PH97 includes a pH (glass) electrode, solid state reference electrode, solution ground and a Pt 1000 temperature element. All these components are sealed in a rugged Ryton™ body.

### PH87/B Retractable Holder

#### SPECIFICATIONS

pH range:	0-14pH
ORP range: (requires/ORP option which replaces pH bulb)	-5000 mV to 5000 mV
Temperature range:	0-221°F (0-105°C)
Maximum pressure:	100 psig @ 212°F (100°C)
Maximum flow:	10 feet per second (3 meters per second)
Reference electrode:	Ag-Ag/Cl

### PH97/DP pH Electrode

#### Specifications:

pH Range:	0-14 pH
ORP range	-5000 mV to 5000 mV (requires/ORP option which replaces pH bulb)
Temperature range:	0-221°F (0-105°C)
Maximum pressure:	100 psig @ 212°F (100°C)
Maximum flow:	10 feet per second (3 meters per second)
Reference electrode:	Ag/AgCl
Temperature compensation:	Pt1000



The Model PH87 assemblies are constructed of chemically-resistant titanium and include blowout safety protection utilizing a flared tip design which provides a metal to metal stop during retraction. Integral junction boxes are provided for simple installation and wiring. The retractable assembly is suitable for removal from a process line or vessel at pressures up to 70 PSI without interrupting the flow or draining the tank. The PH87 comes different lengths to simplify proper insertion in the process line or tank.

Another alternative Yokogawa offers is the model PH18 differential pH sensor that is constructed of an enamel coated steel rod. The PH18 consists of a pH sensitive enamel and a sodium ion enamel combined with an integral temperature element, to form a probe without internal solutions. Therefore, the PH18 contains no reference electrode or junction that could become clogged or give way to fouling. This sensor has very little maintenance, once it is initially installed and calibrated in place for the first time.

### PH18 Differential Electrode

#### GENERAL SPECIFICATIONS

##### Model PH18 Differential pH Sensor

Temperature sensor	: Pt1000 Ω RTD
Wetted parts	: pH sensor -pH sensitive enamel : Reference sensor - Na <sup>+</sup> sensitive enamel : Liquid earth via SS adapter : O-rings (EPDM) : Adapters (SS 316)
Max. measuring range	: 3 to 11 pH (The actual range will be advised with reference to the completed application data sheet)
Temperature range	: 0 to 140 °C (284 °F)
Pressure range	: -1 to 15 Bar (214 psi)

