

General Specifications

GS12J6K4-01E-A

Model DO30G and FD30/PB30 Sensor and fittings for Dissolved Oxygen

The **DO30G sensor** for dissolved oxygen is designed for use in water treatment plants such as sewage treatment works, effluent activated sludge process, and potable water treatment. It is also effective in river monitoring, intake protection, fish farming and other fields where water quality is important.

This galvanic cell has a fast response time and good long term stability, and features replaceable diaphragm and cable for easy maintenance. A temperature sensor is incorporated for compensation. The DO30G sensor can be used in either the PB30 floating ball fitting or in the FD30 immersion fitting.

The **PB30 floating ball holder** for the DO30G features a design which minimises fouling by the process. A brass ring around the sensor facilitates a check for membrane integrity, and helps to eliminate any deposits of algae, making a cleaning system unnecessary for the model PB30. Maintenance is very simple, with only periodic inspection and calibration needed.

The **FD30 PVC immersion fitting** is designed for installing the DO30G sensor in tanks, open vessels and drains. It can be supplied in lengths between 0.5 and 2.0 meter. Flange mounting is also possible.

In applications with a heavy load of solids the use of a cleaning system is recommended, so an option, a "jet cleaner" is available for the immersion fitting. The use of this device can extend the continuous measurement period and eases maintenance.



Features

DO30G • Fast response time

- Good long term stability
- Easy membrane change

PB30 • Easy to install

- Easy calibration
- Sensor diagnosis for membrane integrity

FD30 • Various immersion depths

- Flange mounting possible
- Cleaner option

System configuration

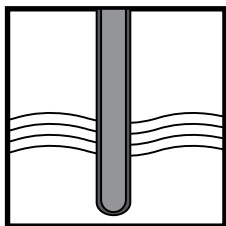

Sensors

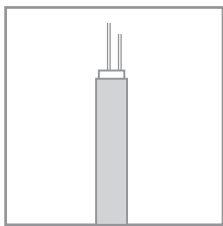

Cables

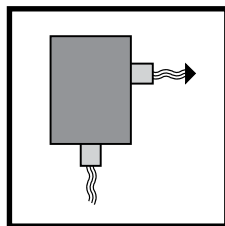

Fittings

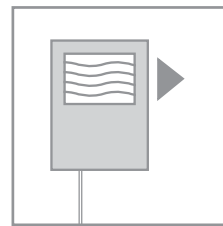

Transmitters

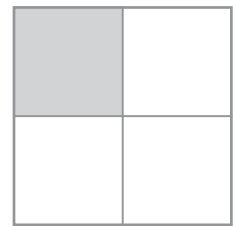

Accessories

DO30G Sensor

The DO30G sensor, which replaces the previous model DO30, is the heart of Yokogawa's Dissolved Oxygen measuring loop. It can be supplied with membrane thicknesses of 50 µm. The integral connection cable comes in 5 different lengths between 3 meters and 20 meters. For convenience the membrane sets and O-rings available as spare parts.

Specifications

General

Measuring	: Dissolved Oxygen
Measuring Principle	: Galvanic cell method
Measuring Range	
- Minimum	: 0-2.5 ppm
- Maximum	: 0 to 20 ppm
Liquid operating conditions	
- Temperature	: 0 to 40°C
- Pressure	: 0 to 100 kPa
- Flow speed	: 20 cm/s or more
Response time	: < Within 2 minutes (90% response)

Repeatability : 0.1 mg/l or 3% FS, whichever is greater (including sensor)

Sensor

Temperature compensation sensor	: Pt1000
Wetted part materials	: Hard PVC Fluorinated polymer (FEP) Stainless steel (SUS304) Nitrile rubber Soft PVC Polycarbonate
Membrane	: 50 µm

Shipping details

Weight :	: Approx. 0.9 kg (with cable length of 5m) Weight of the sensor is approx. 0.3 kg
Package size	: 295 x 230 x 165 mm

Model and Suffix Code

DO Sensor

Model	Suffix Code	Option code	Description
DO30G	DO sensor
-	-NN.....	Always -NN
Membrane thickness	-50.....	50 µm
Cable length	-03.....	3m
	-05.....	5m
	-10.....	10m
	-15.....	15m
	-20.....	20m
Cable terminal	-PN.....	Always -PN

Accessories

Parts set for maintenance

Model	Suffix Code	Option code	Description
DOX8A	Part set for maintenance (for membrane thickness of 50 µm)
Sensor	-M.....	For membrane replacing type sensor
-	*B.....	Style B

DOX8A Parts Set for Maintenance

A set of zero-adjusting reagent and maintenance parts

<Contents>

Zero adjusting reagent (sodium sulfite 500 g)	1 bottle
Membrane assembly (for membrane thickness of 50 µm)	3 sets
Electrolyte for sensor (50 ml)	1 bottle
Syringe for replacing electrolyte	1
Polish for silver electrode (30 g)	1 bottle
Polyethylene beaker (200 ml)	1

Spare Parts

Part Name	Part No.	Remarks
Membrane and electrolyte for sensor	K 9171HK	3 membrane assemblies (thickness of 50 µm) 50 ml or electrolyte*
Zero adjusting reagent	L 9920BR	Sodium sulfite 500g
Polisher	K 9088PE	For polishing silver electrode 30g
Electrolyte	K 9171DN	Refill solution 50ml

* Available with longer lead time, purchase DOX8A-M*B kit, for quicker delivery for membrane and electrolyte replacement

Dimensions

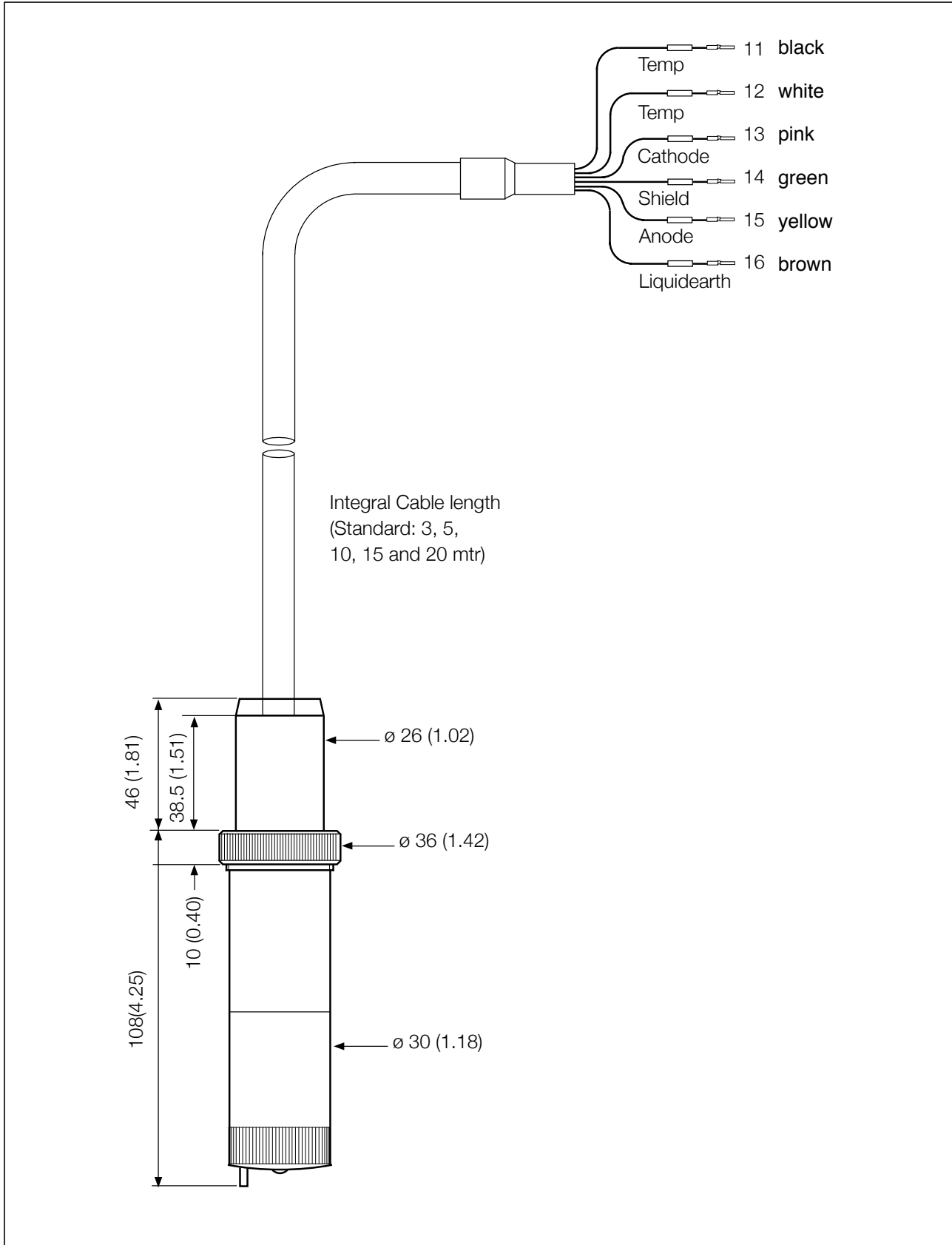

Figure 1. DO30G sensor

FD30 Immersion Holder

Intended to mount the sensor in tanks, the immersion fittings should be installed where the point of measurement truly represents the entire solution. Avoid areas where the measurement value varies significantly e.g. stagnant corners.

Select a place where the sensor is always immersed in the process liquid. The FD30 fitting is standard equipped with membrane check-facility and can be specified with or without a flange. Cable length and sensor membrane can also be specified in the MS code. For types without a flange, a mounting set and a jet cleaner are available as options.

/JC Jet Cleaner

This optional cleaner gives the opportunity to avoid build up of deposits and consequent fouling on the sensor membrane. This is achieved by spraying water (or air) onto the membrane of the DO-sensor. The spray head is equipped with a built-in (non-return) valve to avoid penetration of the process liquid into the cleaning system. The EXA DO402 has a built-in wash timer with programmable wash time, interval time and recovery time for the automatic cleaning of the sensor.

Specifications

General

Wetted materials

Fitting

- Body & flange : Polyvinylchloride (PVC)
- O-rings : Silicone rubber
- Blanking plug : Ryton R4 (remove before use!)
- Conductive bushing : Brass

Options

- Sensor/cable : See DO30G
- Flex. conduit : PVC and Nylon
- Jet cleaner : PVC, Nylon, PVDF and PTFE
- Mounting : Galvanized steel

Weight

- Without flange : 1.35 kg + 0.2 kg per 0.5 meter
- With flange : 0.5 kg extra

Functional

Fitting

- Temperature : Min. : -10°C
Max. : +50°C
- Pressure : Max. 2 bar
- Immersion length : 0.5 to 2.0 m (10 cm steps)
When ordered as a subassembly (pipe length 00), a tube with PVC cement will be delivered with the holder.

Cleaner (optional)

- Temperature : As FD30V27
- Pressure : As FD30V27
- Immersion length : Additional + 4 cm.

Model and Suffix Codes

Immersion Fitting

Model	Suffix	Option	Description
FD30V27			Immersion Fitting PVC
Immersion length	-00 -xx		Pipe supplied by user Between 0.5 and 2.0 (in steps of 0.1m) Example: 06 = 0.6 m
Mounting flange	-FN -F1 -F2		No flange DIN DN50 PN10 ANSI 2" 150 lbs
	*A		Style A
Protection hose		/PH5 /PH10	5 meter 10 mtr
Jet Cleaner		/JC	*
Mounting set		/MS1	*

* Not available with flanged versions.

Accessories

Accessories and Options

Part no.	Description
K1530YZ	Jet Cleaner (/JC)
K1541ZY	Mounting set (/MS1)
K1500CJ	5 meter Protection hose kit (/PH5)
K1500CK	10 meter Protection hose kit (/PH10)

Spare Parts

Part no.	Description
K1530UK	Spray nozzle for Jet Cleaner
K1530UL	Tubing 1/4" for Jet Cleaner, 10 meter
K1500AW	Flexible conduit 5 meter
K1500AX	Flexible conduit 10 meter
K1500AY	Connection parts for flexible conduit
K1500AZ	Nozzle parts
K1500FX	O-ring set (5 pieces, silicone) for sealing the sensor
K1500FY	O-ring set (5 pieces, silicone) for mounting the sensor in the fitting

Dimensions

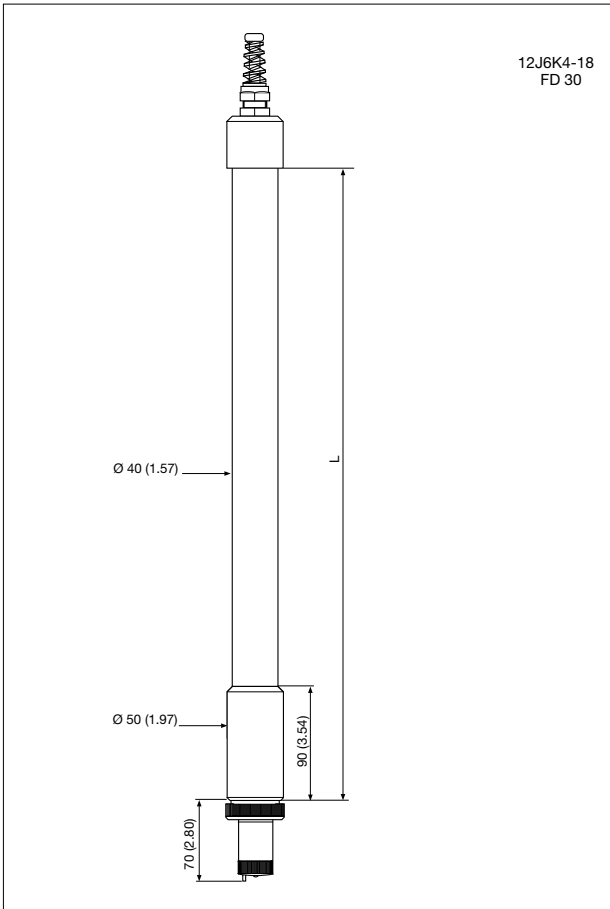

Figure 2. Immersion assembly without flange

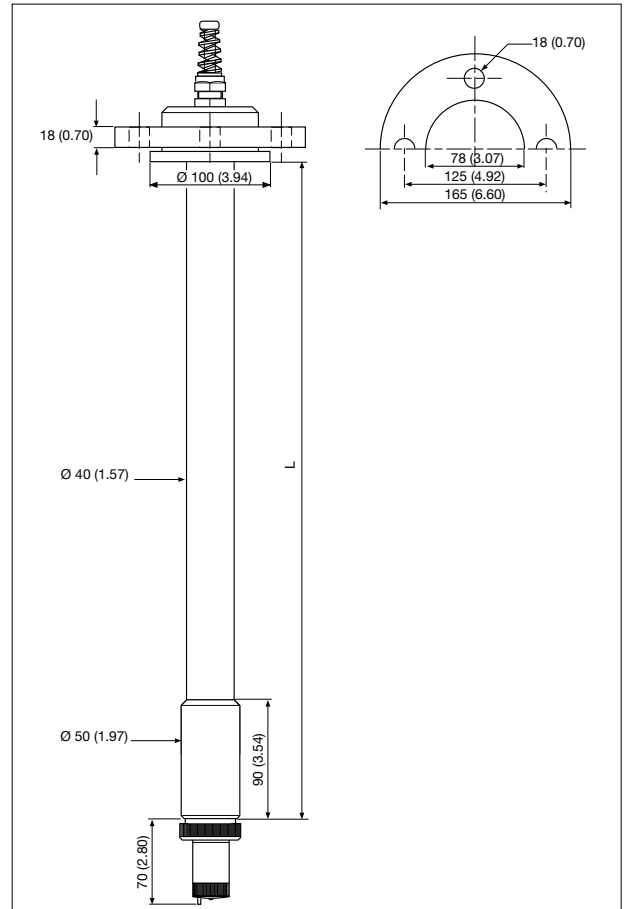

Figure 3. Immersion assembly with flange

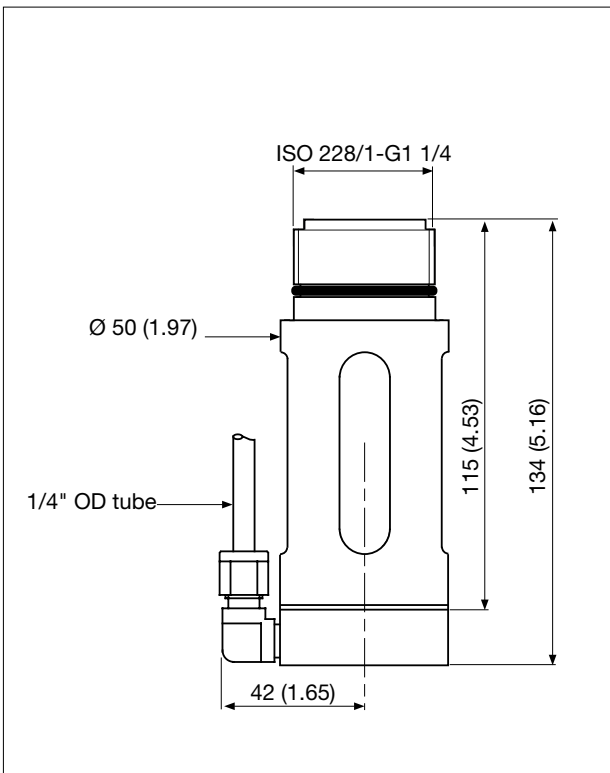

Figure 4. Option /JC Jet cleaner

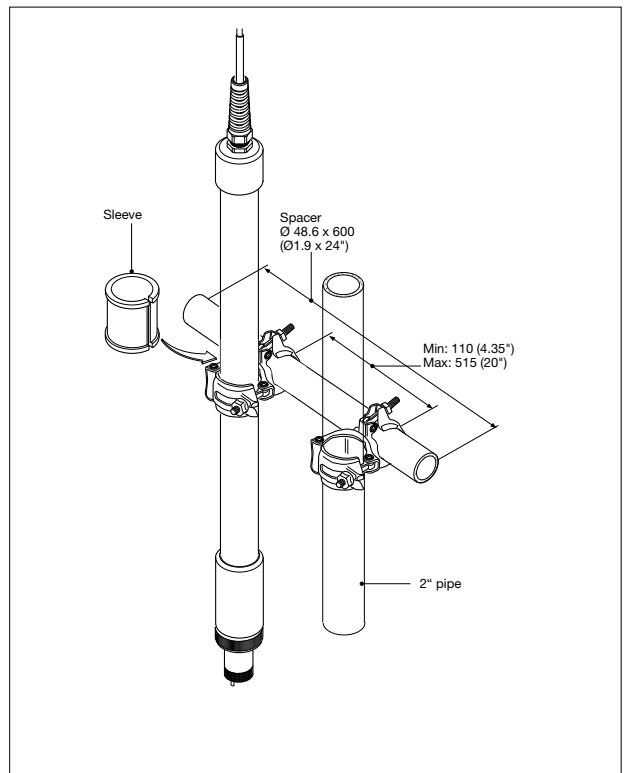

Figure 5. Option /MS1 Mounting set

PB30 Floating Ball

The design of the PB30 floating ball ensures minimum user maintenance. The constant movement of the ball with the action of waves on the surface of the tank provides a good flow of sample at the membrane surface. Constant measurement depth is also assured. The solution ground ring in brass, gives the facility of a membrane check, while also minimising algae growth on the sensor. For convenience, the PB30 includes a winch mounting mechanism, and is normally specified as a unit complete with sensor and cable.

Specifications

Fitting

- Wetted parts : High impact polystyrene, PVC & Brass
- Temperature : 0-40°C
- Mounting bracket : Galvanised steel, for rail, or surface mounting.
- Sensor/cable : See DO30G

Note:

The standard pipe used for PB30 has a 50 mm outer diameter. For 1 1/2" pipe it is necessary to use the 1 1/2" adapters delivered with the PB30-00.

Shipping details

- Weight : Approx 12.5 kg.
- Package size : 490x320x340 mm
- Main support arm : 2.5 m

Dimensions

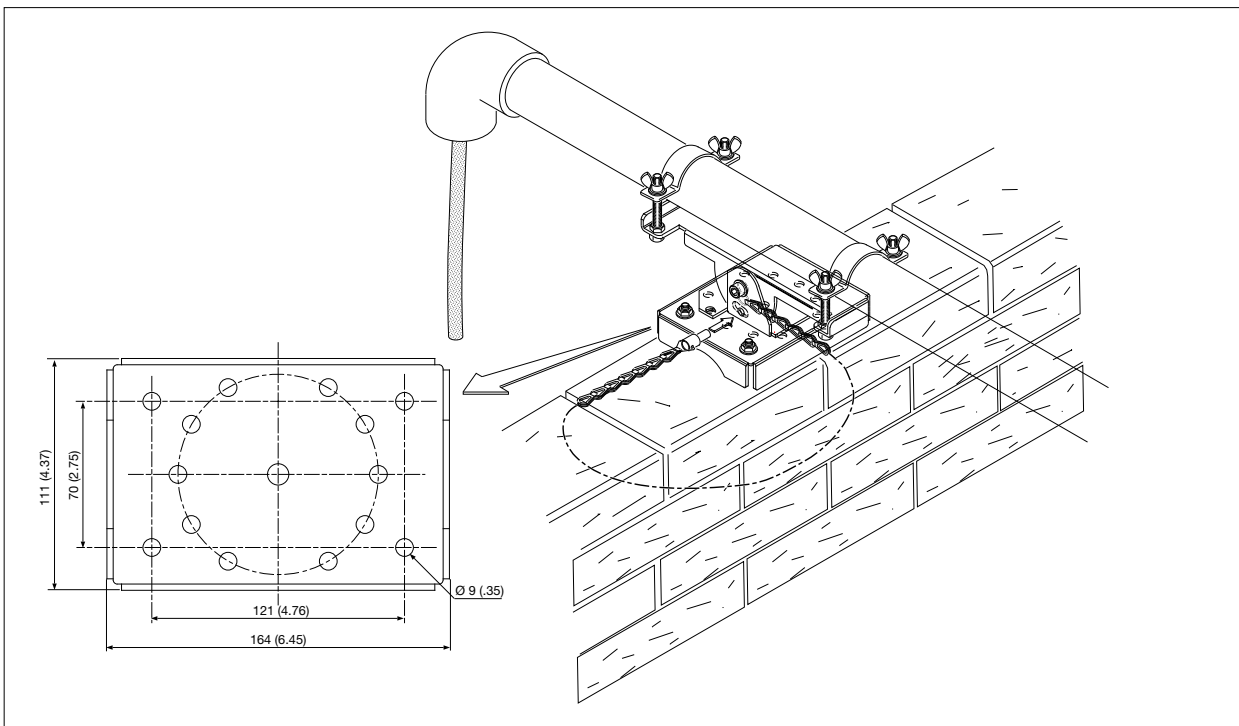

Figure 6.

Model and Suffix Codes

Floating Ball

Model	Suffix Code	Description
PB30		Floating Ball Fitting
Pipe length	-00 -25	Pipe supplied by user 2.5 meter
Sensor type	-SNN	No sensor
Cable length	-00	No cable

ACCESSORIES

Spare Parts

Part no.	Description
K1530DQ	Mounting bracket for PB30
K1500AV	O-ring set for PB30 25.3x3.2 (5x)
K1530SA	Floating ball ass.

Note: The standard pipe used for PB30 has a 50 mm outer diameter. For 1 1/2" pipe it is necessary to use the 1 1/2" adapters delivered with the PB30-00.

Dimensions

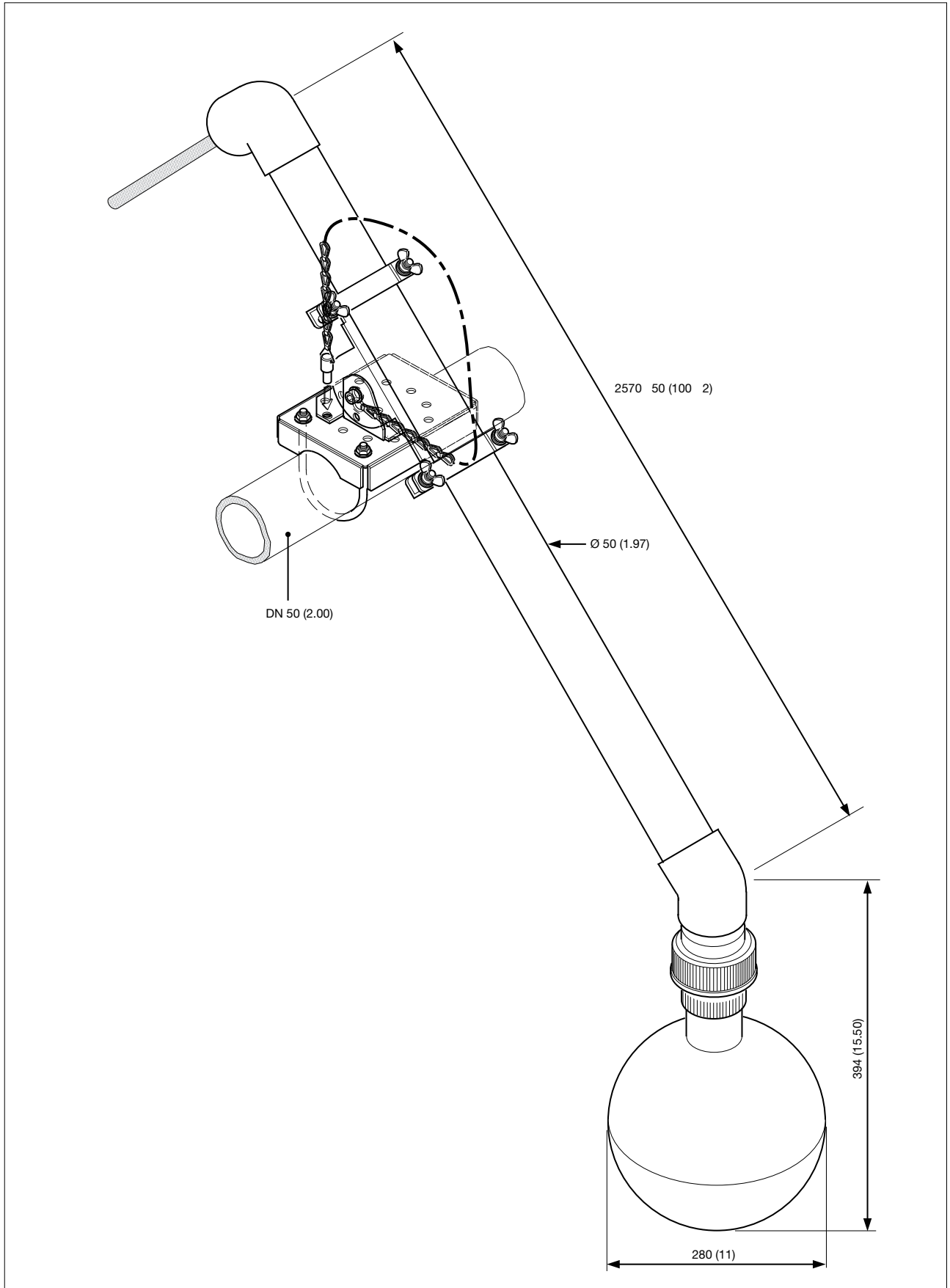

Figure 7. Universal mounting assembly for floating ball fitting

Accessories

Part no.	Description	DO30G	FD30	PB30
K1530YZ	Jet Cleaner (/JC)		x	
K1541ZY	Mounting set (/MS1)		x	
K1500CJ	Flexible conduit 5 meter and connection set (/PH5)		x	
K1500CK	Flexible conduit 10 meter and connection set (/PH10)		x	
DOX8A-M*B	Parts set for Maintenance of DO30G sensor	x		

Spare Parts

Part no.	Description	DO30G	FD30	PB30
K1530UK	Spray nozzle for Jet Cleaner		x	
K1530UL	Tubing 1/4" for Jet Cleaner, 10 meter		x	
K1500AW	Flexible conduit 5 meter		x	
K1500AX	Flexible conduit 10 meter		x	
K1500AY	Connection parts for flexible conduit		x	
K1500AZ	Nozzle parts		x	
K1500FX	O-ring set (5 pieces, silicone) for sealing the sensor		x	
K1500FY	O-ring set (5 pieces, silicone) for mounting the sensor in the fitting		x	
K1530QA	Lower support for PB30			x
K1530DQ	Mounting bracket for PB30			x
K1500AV	O-ring set for PB30			x
K1530SA	PB30 assembly			x
K9171HK	Membrane and electrolyte for	x		
L9920BR	Zero adjusting reagent	x		
K9088PE	Polisher	x		
K9171DN	Electrolyte solution	x		