



Model EXAxt ZR Series HART Protocol

IM 11M12A01-51E

Introduction

This is the HART Communicator manual for the EXAxt ZR series of Model ZR202G, ZR402G. This manual is described under the HART equipment that is ready to operate.

When using the EXAxt ZR HART Protocol for the Zirconia Oxygen Analyzer/High Temperature Humidity Analyzer, please refer to the following instruction manuals.

Zirconia Oxygen Analyzer

IM 11M12A01-02E for ZR22G and ZR402G Separate type Zirconia Oxygen Analyzer

IM 11M12A01-04E for ZR202G Integrated type Zirconia Oxygen Analyzer

Zirconia High Temperature Humidity Analyzer

IM 11M12A01-03E for ZR22G and ZR402G Separate type Zirconia High temperature Humidity Analyzer

IM 11M12A01-05E for ZR202G Integrated-type Zirconia High temperature Humidity Analyzer

◆ Special descriptions in this manual

This manual generally describes the products and instruction manuals as given below.

Products

ZR202G: Integrated type converter

ZR402G: Separate type converter

Instruction manual

ZR202G Instruction Manual: IM 11M12A01-04E or IM 11M12A-05E

ZR402G Instruction Manual: IM 11M12A01-02E or IM 11M12A-03E

◆ Drawings in this manual

Drawings in this manual may be emphasized, abbreviated or partially omitted for easier explanation.

Screen images in this instruction manual are drawings to give you an idea of functions and operation; they may not be exactly the same as actual screen displays.

◆ Other items

The contents of this manual are subject to change without prior notice.

Contents

Introduction	i
◆ Special descriptions in this manual	i
◆ Drawings in this manual	i
◆ Other items	i
1. Operation via HART Communicator	1-1
1.1 Conditions of Communication Line	1-1
1.1.1 Interconnection between ZR202G/ZR402G and HART Communicator	1-1
1.1.2 Communication Line Requirements	1-1
2. Basic Operation of the HART Communicator(Model 275)	2-1
2.1 Keys and Functions	2-1
2.2 Display	2-2
2.3 Calling Up Menu Addresses	2-3
2.4 Entering, Setting and Sending Data	2-5
3. Parameters	3-1
3.1 Menu Tree	3-1
3.1.1 Menu Tree for Model ZR202G Integrated type Zirconia Oxygen Analyzer .	3-1
3.1.2 Menu Tree for Model ZR202G Integrated type Zirconia High Temperature	3-5
Humidity Analyzer	
3.1.3 Menu Tree for Model ZR402G Separate type Zirconia Oxygen Analyzer	3-9
3.1.4 Menu Tree for Model ZR402G Separate type Zirconia High Temperature	3-13
Humidity Analyzer	
3.1.5 Menu Tree for Model ZR402G Separate type Zirconia High Temperature	3-18
Humidity Analyzer with Temperature Analog input option	
3.2 Setting Parameters	3-24
3.3 Calibration	3-39
3.4 Blow back (ZR402G only)	3-41
3.5 Self Diagnostics	3-42
4. Maintenance	4-1
4.1 Test Output	4-1
4.2 Read DI	4-2
4.3 Test DO	4-3
4.4 Test Cal. DO	4-4
Revision Record	i

1. Operation via HART Communicator

1.1 Conditions of Communication Line

1.1.1 Interconnection between ZR202G/ZR402G and HART Communicator

The HART Communicator can interface with the ZR202G/ZR402G from the control room, the ZR202G/ZR402G site, or any other wiring termination point in the loop, provided there is a minimum load resistance of 250Ω between the connection and the receiving instrument. To communicate, it must be connected in parallel with the ZR202G/ZR402G, the connections are non-polarized. Figure 1.1 illustrates the wiring connections for direct interface at the ZR202G/ZR402G site. The HART Communicator can be used for remote access from any terminal strip as well.

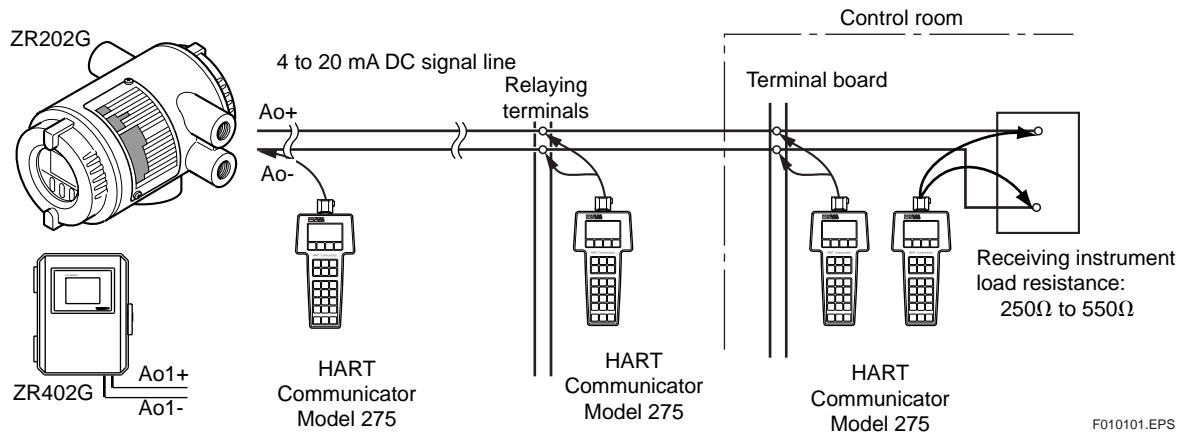

Figure 1.1 Interconnection Diagram

1.1.2 Communication Line Requirements

Specifications for Communication Line:

- Load resistance: 250 to 550Ω (including cable resistance)
When multidrop mode, see Figure 1.2.
 - Minimum cable size: 24 AWG, (0.51 mm diameter)
 - Cable type: Single pair shielded or multiple pair with overall shield
 - Maximum twisted-pair length: 6,500 ft (2,000 m)
 - Maximum multiple twisted-pair length: 3,200 ft (1,000 m)
- Use the following formula to determine cable length for a specific application;

$$L = \frac{65 \times 10^6}{(R \times C)} - \frac{(C_f + 10,000)}{C}$$

- where:
- L = length in feet or meters
 - R = resistance in ohms, current sense resistance
 - C = cable capacitance in pF/ft or pF/m
 - C_f = 50,000 pF

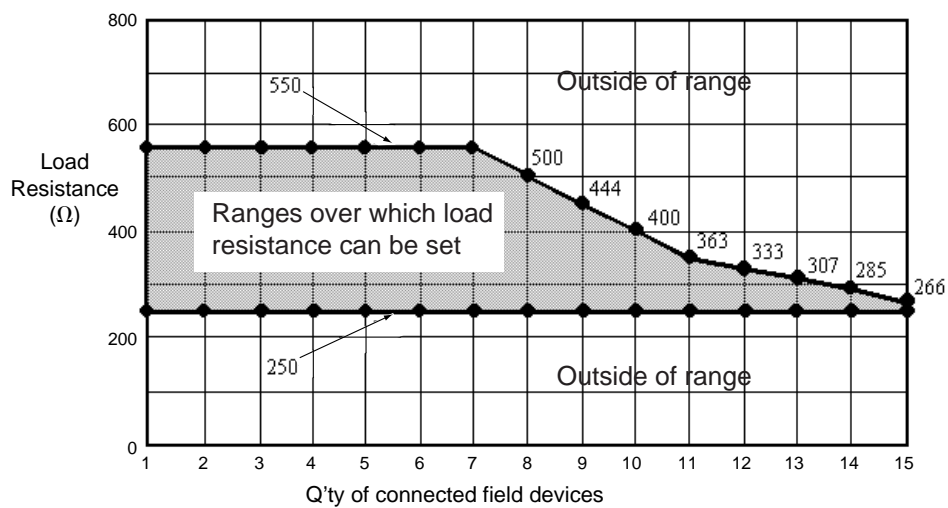

F010201.EPS

Figure 1.2 Load Resistance and Quantity of Devices in Multidrop Mode

2. Basic Operation of the HART Communicator(Model 275)

2.1 Keys and Functions

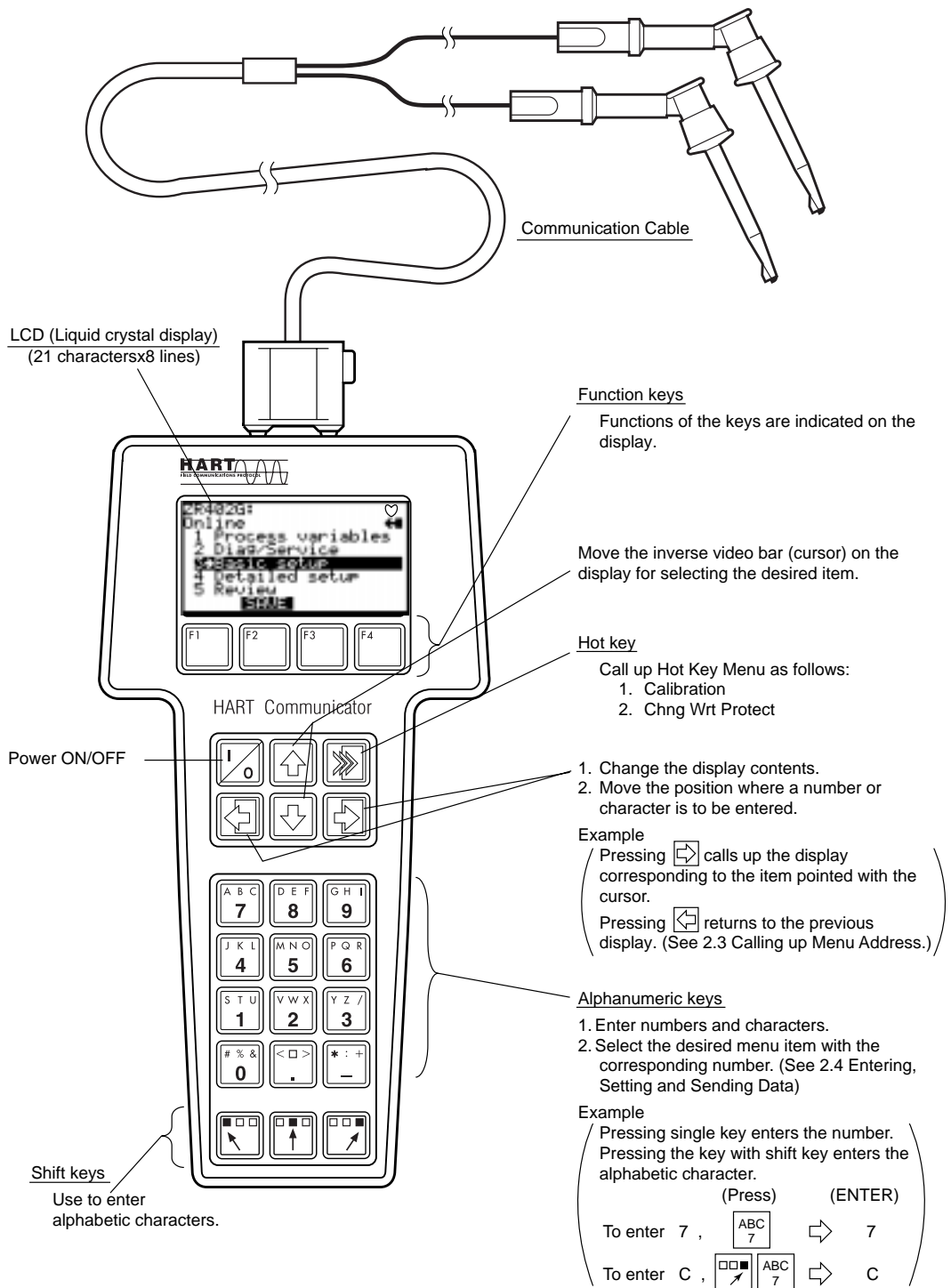

F020101.EPS

Figure 2.1 HART Communicator

2.2 Display

The HART Communicator automatically searches for ZR202G/ZR402G on the 4 to 20 mA loop when it is turned on. When the HART Communicator is connected to the ZR202G/ZR402G, it displays “Online” menu as shown below. (If ZR202G/ZR402G is not found, the communicator displays the message “No Device Found. Press OK....” Press the OK ‘F4’ function key and the main menu appears. Please retry after confirming the connection with the ZR202G/ZR402G.)

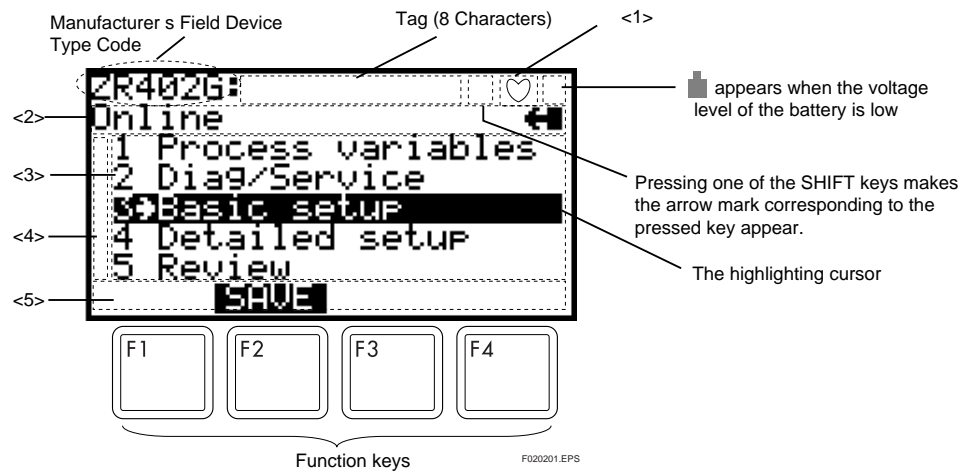

Figure 2.2 Display

- <1> ♥ appears and flashes during communication between the HART Communicator and the ZR202G/ZR402G. At Burst mode*, ♥ appears.
- <2> The current display menu title appears.
- <3> Each item in menu of <2> appears.
- <4> ↓ and/or ↑ appear when the items are scrolled out of the display.
- <5> On any given menu, the label appearing above a function key indicates the function of that key for the current menu.

Note: Refer to “3.4 Setting Parameters (5) Burst Mode”.

Function Key Labels

F1	F2	F3	F4
HELP access on-line help	ON/OFF activates or deactivates a binary variable	ABORT terminate current task	OK acknowledge information on screen
RETRY try to re-establish communication	DEL delete current character or Hot Key Menu item	ESC leave value unchanged	ENTER accept user-entered data
EXIT leave the current menu	SEND send data to device, or mark data to send	QUIT terminate session because of a communication error	NEXT leave the current menu
YES answer to yes/no question	PGUP move up one help screen	PGDN move down one help screen	NO answer to yes/no question
ALL include current Hot Key item on Hot Key Menu for all devices	PREV go to previous message in a list of messages	NEXT go to next message in the list of messages	SKIP do not mark variable to be sent in off-line configuration
SAVE save information to communicator	EDIT edit a variable value	HOME go to the top menu in the device description	ONE include Hot Key item for one device
SEND send data to device, or mark data to send	ADD add current item to Hot Key Menu	BACK go back to menu from which HOME was pressed	

F0204.EPS



2.3 Calling Up Menu Addresses

3.1 Menu Tree shows the configuration of Online Menu which is needed for the operation with HART Communicator. The desired item can be displayed with ease by understanding the menu configuration.

When the HART Communicator is connected to the ZR202G/ZR402G, “**Online**” menu will be displayed after the power is turned on (See Figure 2.2). Call up the desired item as follows:

Key operation

There are two choices to select the desired menu item.

1. Use the  or  key to select the desired item, and then press the  key.
2. Press the number key displayed for the desired item.

- To return to the previous display, press the  key,

If **EXIT**, **ESC** and **ABORT** are displayed, press the desired function Key.

Example: Call up the “**Tag**” to change the tag number.

Check where “**Tag**” is located in the menu configuration. Then, call up “**Tag**” on the display according to the menu configuration.

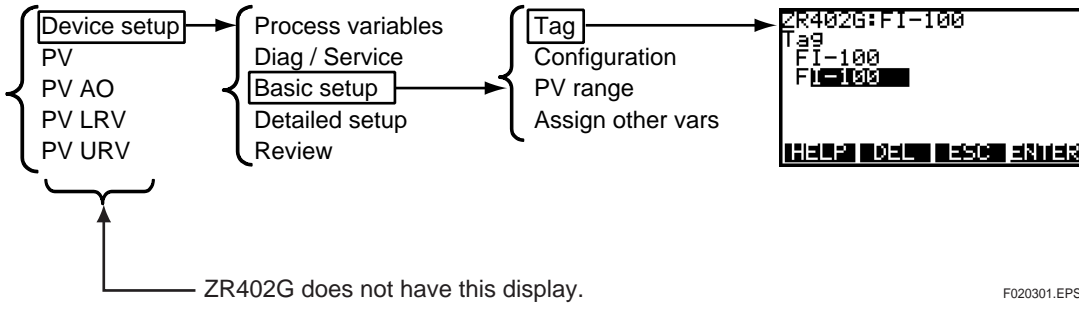

- | | Display | Operation | |
|---|--|---------------|--|
| 1 | <pre>ZR202G: Online 1 Device setup 2 PV 20.95 % 3 PV AO 4.00 mA 4 PV LRV 0 % 5 PV URV 25 % SAVE</pre> | or | <p>Display 1 appears when the HART communicator is turned on.
Select "Device set up"</p> <p>Display 1 is for the ZR202G only. If you use the ZR402G, Display 2 below will appear when the HART communicator is turned on.</p> |
| 2 | <pre>ZR402G:FI-100 Online 1 Process variables 2 Diag/Service 3 Basic setup 4 Detailed setup 5 Review SAVE</pre> | x 2
or
 | <p>Select "Basic setup".</p> |
| 3 | <pre>ZR402G:FI-100 Basic setup 1 Tag FI-100 2 Configuration 3 PV range 4 SV range 5 Assign TV & QV HELP SAVE HOME</pre> | or | <p>Select "Tag".</p> |
| 4 | <pre>ZR402G:FI-100 Tag FI-100 FI-100 HELP DEL ESC ENTER</pre> | | <p>The display for Tag setting appears.
(The default value of "Tag" is blank.)</p> |

2.4 Entering, Setting and Sending Data

The data which are input with the keys are set in the HART Communicator by pressing **ENTER (F4)**. Then, by pressing **SEND (F2)**, the data are sent to the ZR202G/ZR402G. Note that the data are not set in the ZR202G/ZR402G if **SEND (F2)** is not pressed. All the data set with the HART Communicator is held in memory unless power is turned off, so every data can be sent to the ZR202G/ZR402G at one lot.

Operation

Entering data on the “**Tag**” setting display.
On alphabetic characters, only capital letters can be used for setting Tag No. with HART Communicator.

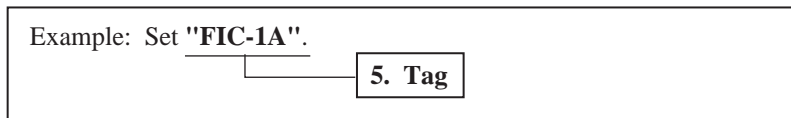

F020401.EPS

Call up "Tag" setting display.
ZR202G

1. Device setup ---> 3.basic setup ---> 5.Tag

ZR402G

- 3.basic setup ---> 5.Tag



F020402.EPS

On the setting display shown above, enter the data as follows:

Character to be entered	Operation	Display
F	DEF 8	
I	GHI 9	
C	ABC 7	
-	*: + —	
1	STU 1	
A	ABC 7	

F020403.EPS

Display

1

```
ZR402G:
Tag
 10-1A
HELP DEL ESC ENTER
```

Operation



(ENTER)

Press **ENTER (F4)** to set the data in the HART Communicator after entering the data.

2

```
ZR402G:
Basic setup
1 10-1A FIC-1A
2 Configuration
3 PV range
4 SV range
5 Assign TV & QV
HELP SEND HOME
```



(SEND)

Press **SEND (F2)** to send the data to the ZR202G / ZR402G.

is flashing during communication.

3

```
ZR402G:FIC-1A
Basic setup
1 10-1A FIC-1A
2 Configuration
3 PV range
4 SV range
5 Assign TV & QV
HELP SAVE HOME
```

label changed to label, and the transmission is completed.

Press **HOME (F3)**, and return "Online Menu".

F020404.EPS



NOTE

Parameter setting on the indicator of ZR202G/ZR402G is prohibited during HART Communication.

3. Parameters



IMPORTANT

- The changed data with the HART Communicator is sent to ZR202G / ZR402G by pressing SEND (F2) of HART Communicator.
- If HART communication is performed while parameters are being set with the analyzer, the changed data may not be set correctly. In such a case, the analyzer provides the following displays:
 - ZR202G; Returns to the Basic panel display.
 - ZR402G; Returns to the Execution / Setup display and the word "Communication" appears in the bottom of the display. However, there is no effect when the analyzer is in the detailed-data display or trend graph display.
- If data settings were carried out simultaneously both in the analyzer and the HART Communicator, the set value on the HART Communicator may not match the actually set value.

3.1 Menu Tree

3.1.1 Menu Tree for Model ZR202G Integrated type Zirconia Oxygen Analyzer

The Online menu summary for Model ZR202G Integrated type Zirconia Oxygen Analyzer is shown below.

- Model ZR202G Integrated type Zirconia Oxygen Analyzer 1page of 4.
- Model ZR202G Integrated type Zirconia Oxygen Analyzer 2page of 4.
- Model ZR202G Integrated type Zirconia Oxygen Analyzer 3page of 4.
- Model ZR202G Integrated type Zirconia Oxygen Analyzer 4page of 4.

● Model ZR202G Integrated type Zirconia Oxygen Analyzer 1page of 4.

Online Menu

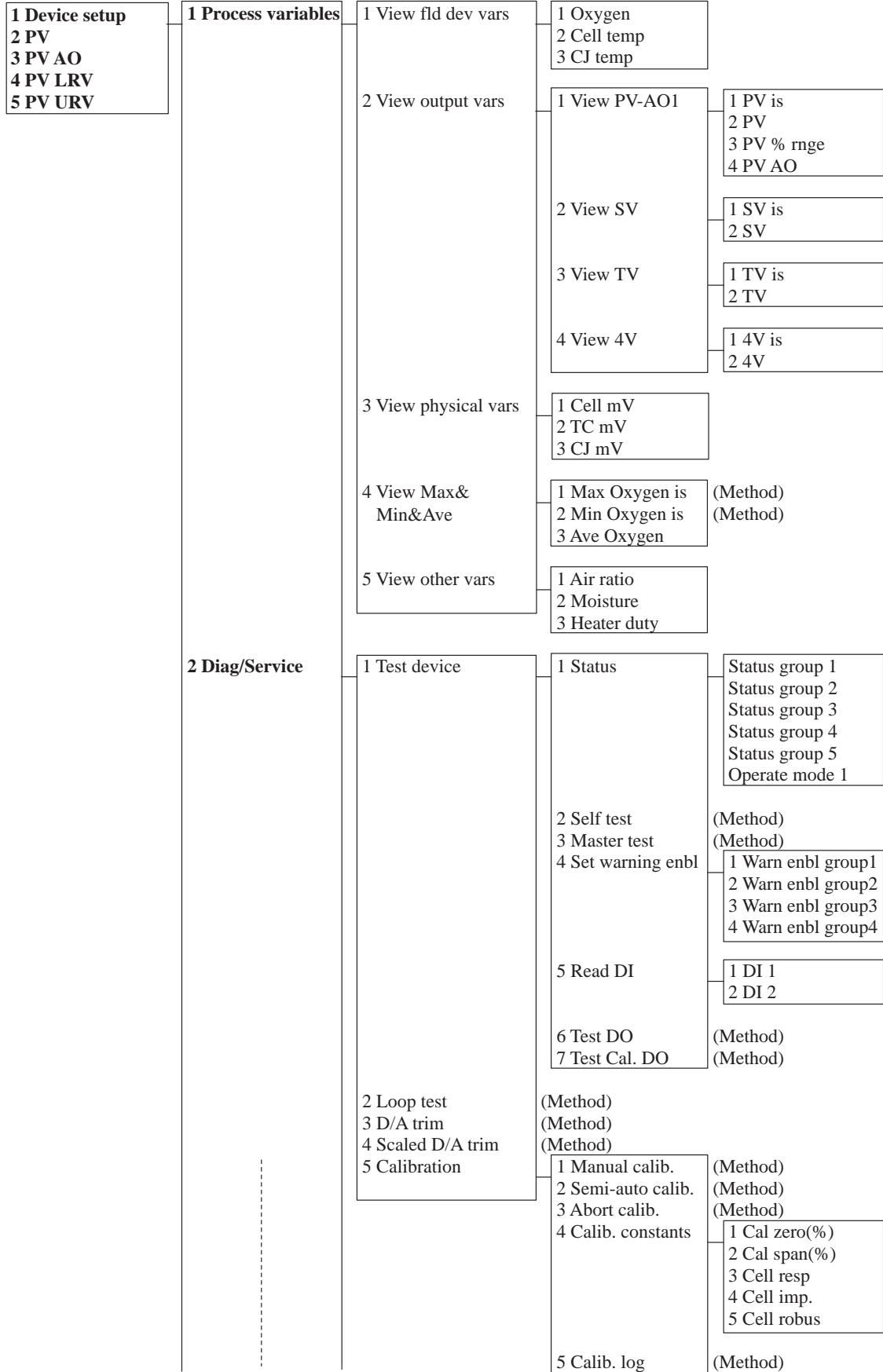

to be continued next page

● Model ZR202G Integrated type Zirconia Oxygen Analyzer 2page of 4.

Online Menu

- 1 Device setup
- 2 PV
- 3 PV AO
- 4 PV LRV
- 5 PV URV

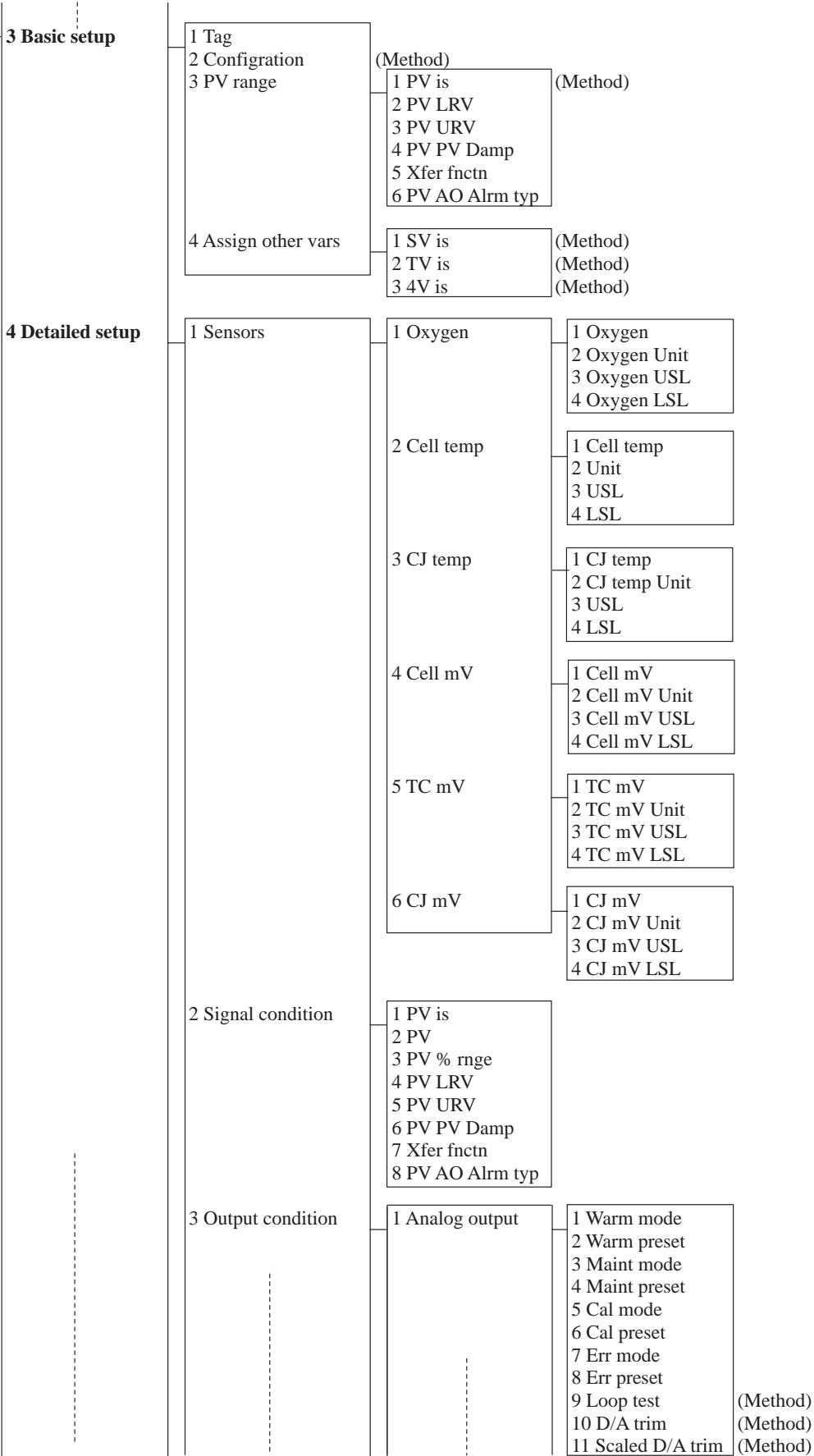

to be continued next page

ZR202Oxygen-2.EPS

● Model ZR202G Integrated type Zirconia Oxygen Analyzer 3page of 4.

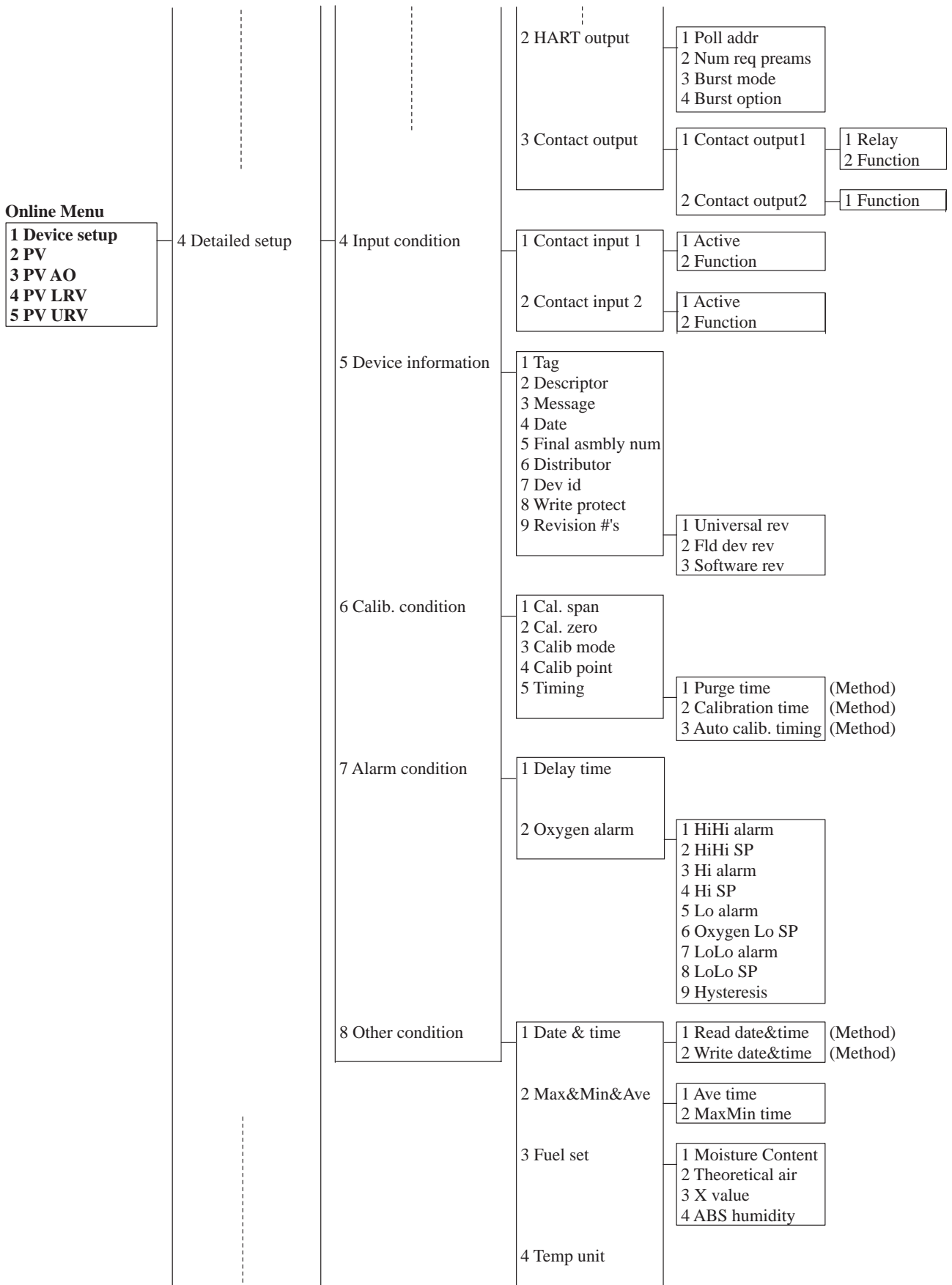

to be continued next page

ZR202Oxygen-3.EPS

● Model ZR202G Integrated type Zirconia Oxygen Analyzer 4page of 4.

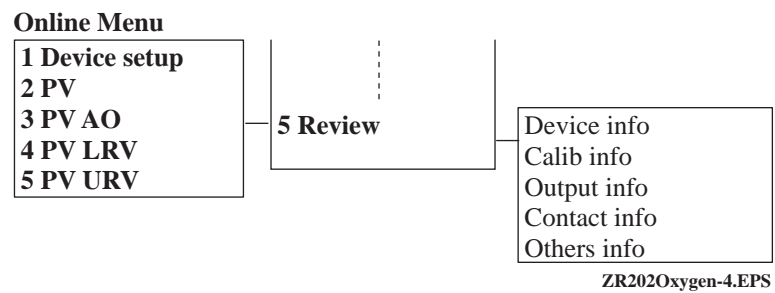

3.1.2 Menu Tree for Model ZR202G Integrated type Zirconia High Temperature Humidity Analyzer

The Online menu summary for Model ZR202G Integrated type Zirconia High Temperature Humidity Analyzer is shown below.

- Model ZR202G Integrated type Zirconia High Temperature Humidity Analyzer 1page of 4.
- Model ZR202G Integrated type Zirconia High Temperature Humidity Analyzer 2page of 4.
- Model ZR202G Integrated type Zirconia High Temperature Humidity Analyzer 3page of 4.
- Model ZR202G Integrated type Zirconia High Temperature Humidity Analyzer 4page of 4.

● Model ZR202G Integrated type Zirconia High Temperature Humidity Analyzer 1page of 4.

Online Menu

<p>1 Device setup 2 PV 3 PV AO 4 PV LRV 5 PV URV</p>	<p>1 Process variables</p>	<p>1 View fld dev vars</p> <p>2 View output vars</p> <p>3 View physical vars</p> <p>4 View Max&Min&Ave</p> <p>5 View other vars</p>	<p>1 Oxygen 2 Humidity 3 Mixing 4 Cell temp 5 CJ temp</p> <p>1 View PV-AO1</p> <p>2 View SV</p> <p>3 View TV</p> <p>4 View 4V</p> <p>1 Cell mV 2 TC mV 3 CJ mV</p> <p>1 Oxygen Max&Min&Ave</p> <p>2 Humid Max&Min&Ave</p> <p>3 Mixing Max&Min&Ave</p> <p>1 Temp 2 Press 3 RH% 4 Dew-P 5 Heater duty</p>	<p>1 PV is 2 PV 3 PV % rnge 4 PV AO</p> <p>1 SV is 2 SV</p> <p>1 TV is 2 TV</p> <p>1 4V is 2 4V</p>	<p>(Method) (Method)</p> <p>(Method) (Method)</p> <p>(Method) (Method)</p>
	<p>2 Diag/Service</p>	<p>1 Test device</p> <p>2 Loop test 3 D/A trim 4 Scaled D/A trim</p>	<p>1 Status</p> <p>2 Self test 3 Master test 4 Set warning enbl</p> <p>5 Read DI</p> <p>6 Test DO 7 Test Cal. DO</p>	<p>Status group 1 Status group 2 Status group 3 Status group 4 Status group 5 Operate mode 1</p> <p>(Method) (Method)</p> <p>1 Warn enbl group1 2 Warn enbl group2 3 Warn enbl group3 4 Warn enbl group4</p> <p>1 DI 1 2 DI 2</p>	<p>(Method) (Method) (Method)</p>

to be continued next page

● Model ZR202G Integrated type Zirconia High Temperature Humidity Analyzer 2 page of 4.

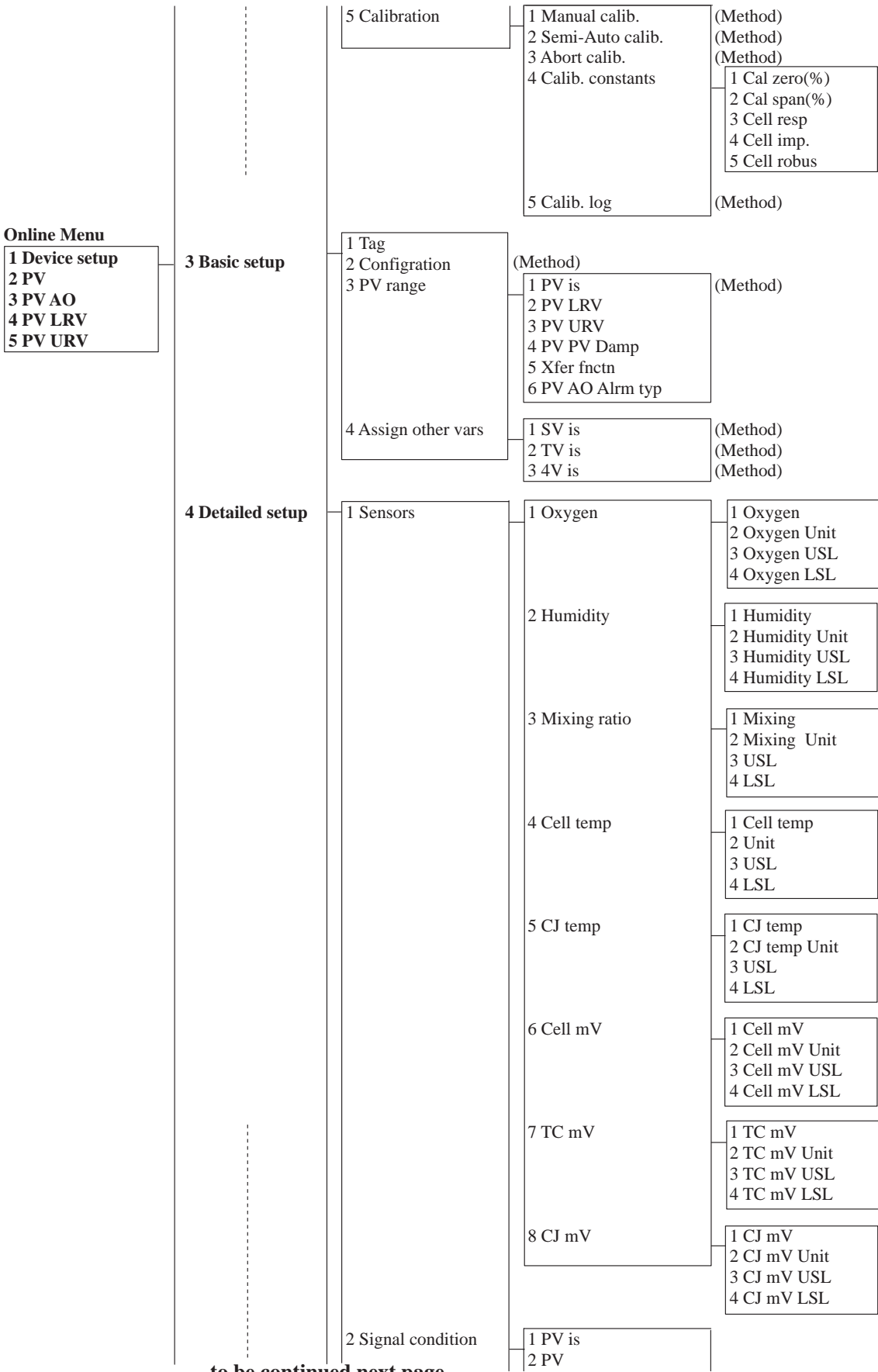

to be continued next page

● Model ZR202G Integrated type Zirconia High Temperature Humidity Analyzer 3 page of 4.

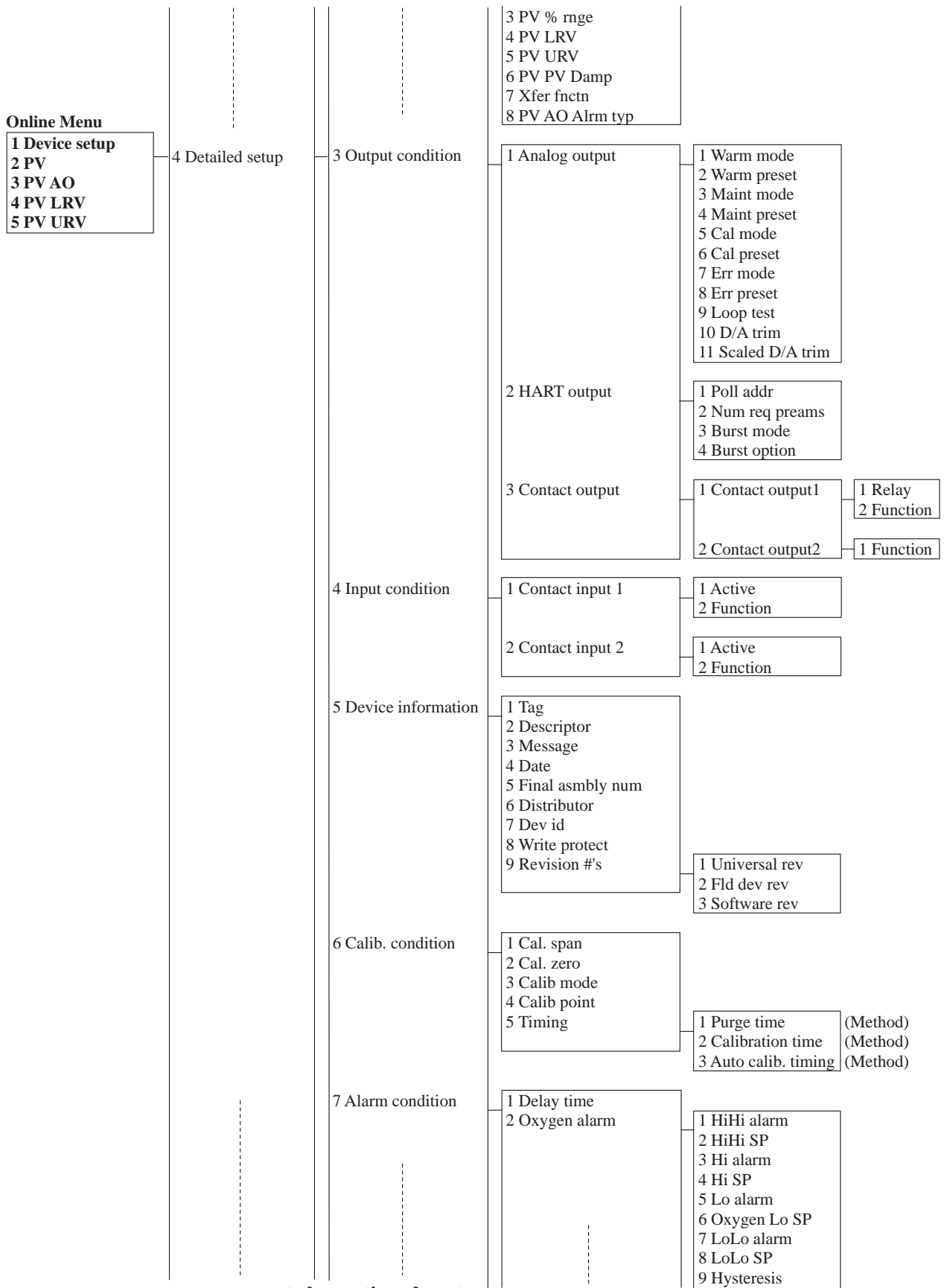

to be continued next page

ZR202Humidity-3.EPS

● Model ZR202G Integrated type Zirconia High Temperature Humidity Analyzer 4 page of 4.

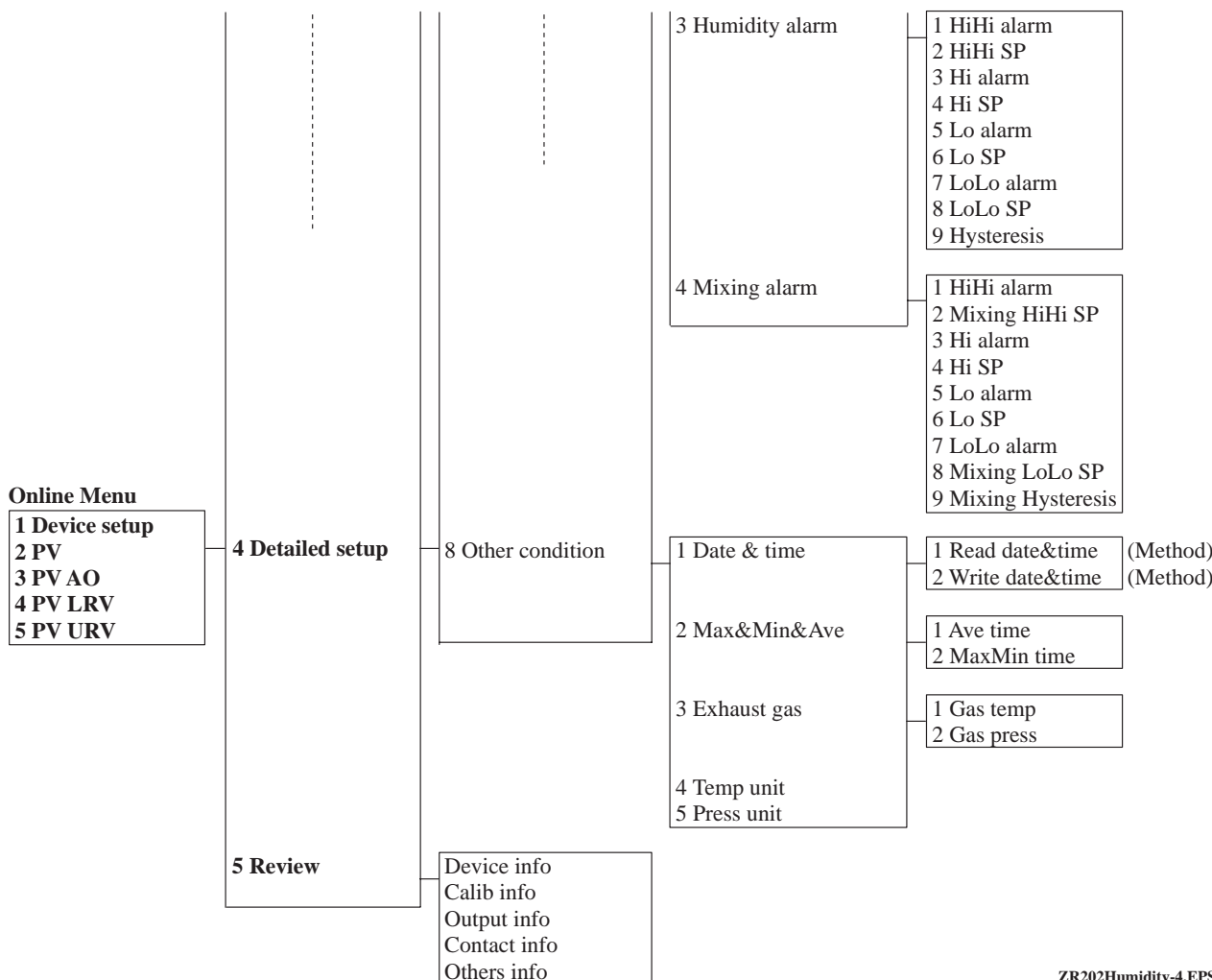

ZR202Humidity-4.EPS

3.1.3 Menu Tree for Model ZR402G Separate type Zirconia Oxygen Analyzer

The Online menu summary for Model ZR402G Sparate type Zirconia Oxygen Analyzer is shown below.

- Model ZR402G Sparate type Zirconia Oxygen Analyzer 1page of 4.
- Model ZR402G Sparate type Zirconia Oxygen Analyzer 2page of 4.
- Model ZR402G Sparate type Zirconia Oxygen Analyzer 3page of 4.
- Model ZR402G Sparate type Zirconia Oxygen Analyzer 4page of 4.

● Model ZR402G Sparate type Zirconia Oxygen Analyzer 1page of 4.

Online Menu

1 Process variables	1 View fld dev vars	1 Oxygen 2 Cell temp 3 CJ temp		
	2 View output vars	1 View PV-AO1	1 PV is 2 PV 3 PV % rng 4 PV AO	
		2 View SV-AO2	1 SV is 2 SV 3 SV % rng 4 SV AO	
		3 View TV	1 TV is 2 TV	
		4 View 4V	1 4V is 2 4V	
	3 View physical vars	1 Cell mV 2 TC mV 3 CJ snsr		
	4 View Max&Min&Ave	1 Max Oxygen is 2 Min Oxygen is 3 Ave Oxygen	(Method) (Method)	
	5 View other vars	1 Air ratio 2 Moisture 3 Heater duty		
	2 Diag/Service	1 Test device	1 Status	Status group 1 Status group 2 Status group 3 Status group 4 Status group 5 Operate mode 1
			2 Self test 3 Master test 4 Set warning enbl	(Method) (Method) Warn enbl group1 Warn enbl group2 Warn enbl group3 Warn enbl group4
5 Read DI			1 DI1 2 DI2	
6 Test DO 7 Test Cal. DO			(Method) (Method)	
2 Fix analog output 3 Trim analog output 4 Calibration			(Method) (Method) 1 Manual calib. 2 Semi-auto calib. 3 Abort calib. 4 Calib. constants	(Method) (Method) (Method) 1 Cal zero(%) 2 Cal span(%) 3 Cell resp 4 Cell imp. 5 Cell robus
	5 Calib. log	(Method)		

to be continued next page

● Model ZR402G Sparate type Zirconia Oxygen Analyzer 2 page of 4.

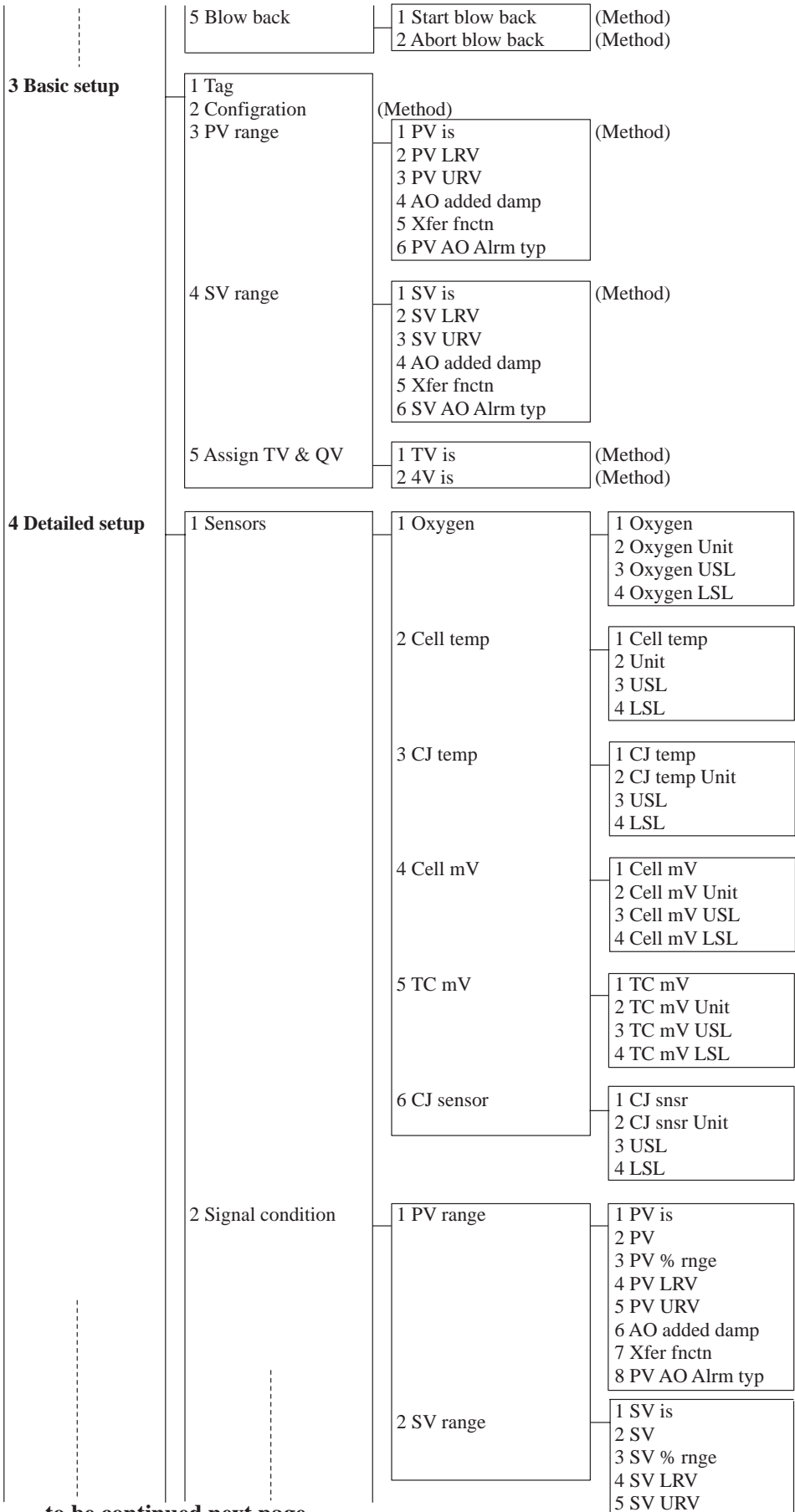

to be continued next page

● Model ZR402G Sparate type Zirconia Oxygen Analyzer 3 page of 4.

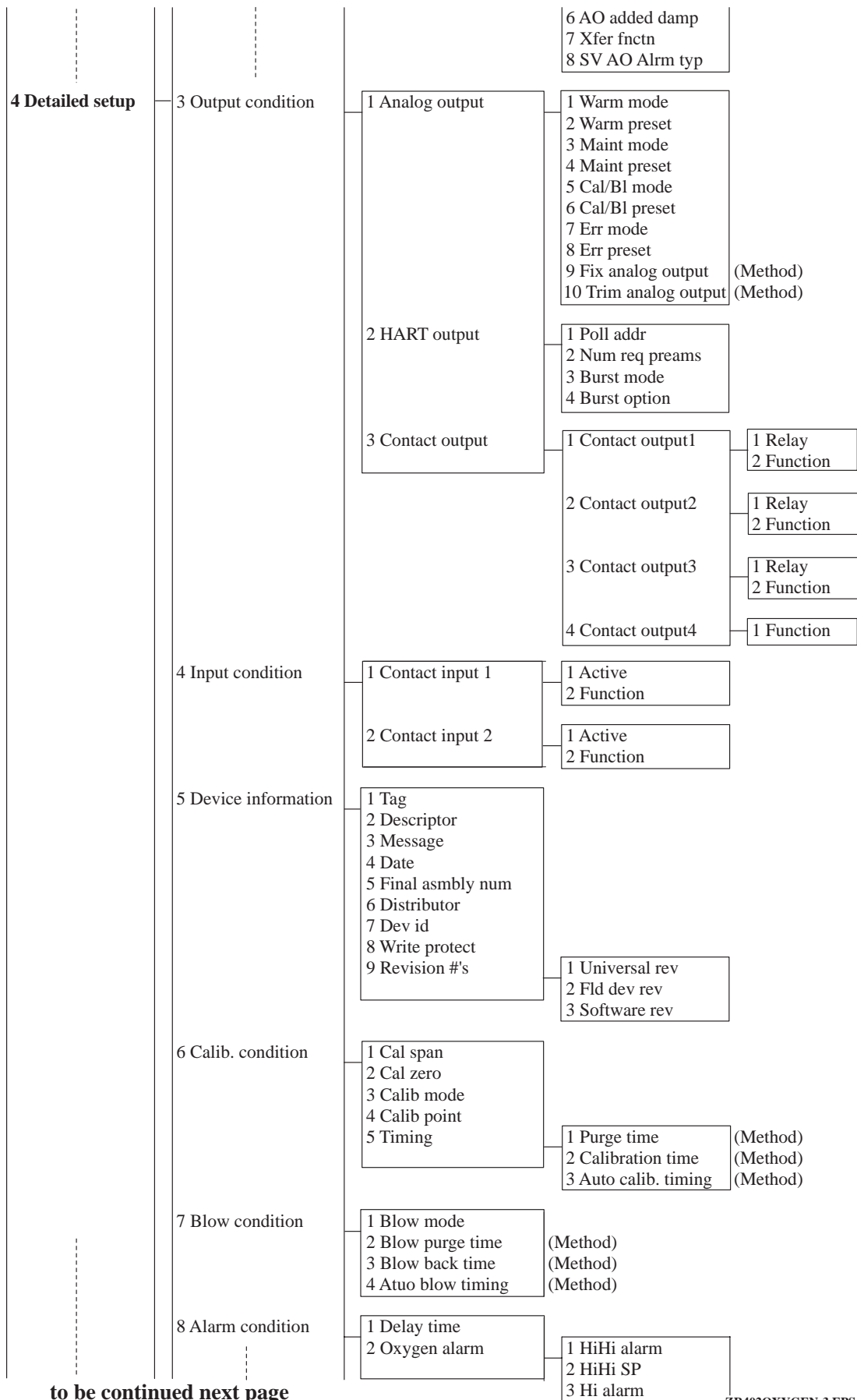

to be continued next page

ZR402OXYGEN-3.EPS

● Model ZR402G Sparate type Zirconia Oxygen Analyzer 4 page of 4.

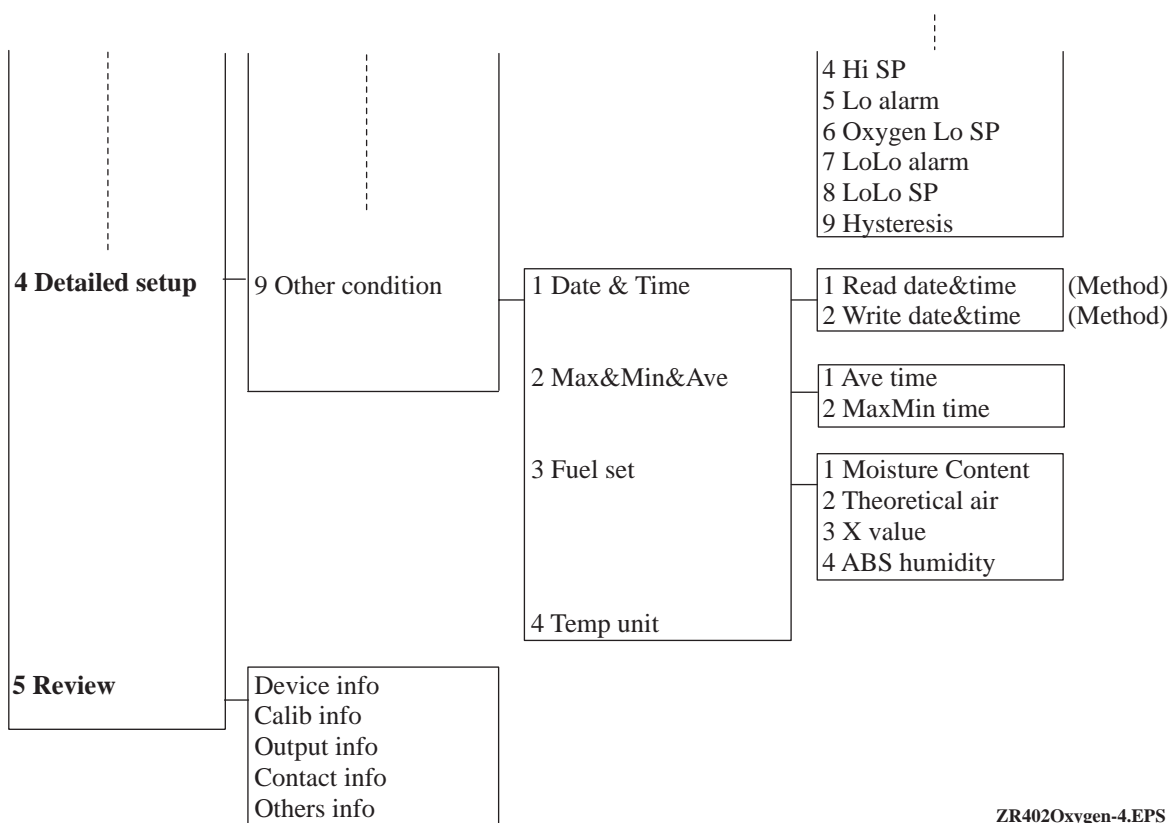

ZR402Oxygen-4.EPS

3.1.4 Menu Tree for Model ZR402G Sparate type Zirconia High Temperature Humidity Analyzer

The Online menu summary for Model ZR402G Sparate type Zirconia High Temperature Humidity Analyzer is shown below.

- Model ZR402G Sparate type Zirconia High Temperature Humidity Analyzer 1page of 4.
- Model ZR402G Sparate type Zirconia High Temperature Humidity Analyzer 2page of 4.
- Model ZR402G Sparate type Zirconia High Temperature Humidity Analyzer 3page of 4.
- Model ZR402G Sparate type Zirconia High Temperature Humidity Analyzer 4page of 4.

● Model ZR402G Separate type Zirconia High Temperature Humidity Analyzer 1 page of 4.

Online Menu

1 Process variables	1 View fld dev vars	1 Oxygen 2 Humidity 3 Mixing 4 Cell temp 5 CJ temp	
	2 View output vars	1 View PV-AO1	1 PV is 2 PV 3 PV % rng 4 PV AO
		2 View SV-AO2	1 SV is 2 SV 3 SV % rng 4 SV AO
		3 View TV	1 TV is 2 TV
		4 View 4V	1 4V is 2 4V
3 View physical vars	1 Cell mV 2 TC mV 3 CJ snsr		
4 View Max&Min&Ave	1 Oxygen Max&Min&Ave	1 Max oxygen is 2 Min oxygen is 3 Ave oxygen	(Method) (Method)
	2 Humid Max&Min&Ave	1 Max humidity is 2 Min humidity is 3 Ave humid	(Method) (Method)
	3 Mixing Max&Min&Ave	1 Max mixing is 2 Min mixing is 3 Ave mixing	(Method) (Method)
5 View other vars	1 Temp 2 Press 3 RH% 4 Dew-P 5 Heater duty		
2 Diag/Service	1 Test device	1 Status	Status group 1 Status group 2 Status group 3 Status group 4 Status group 5 Operate mode 1
		2 Self test	(Method)
		3 Master test	(Method)
		4 Set warning enbl	Warn enbl group1 Warn enbl group2 Warn enbl group3 Warn enbl group4
		5 Read DI	1 DI1 2 DI2
		6 Test DO	(Method)
	7 Test Cal. DO	(Method)	
2 Fix analog output	(Method)		
3 Trim analog output	(Method)		

to be continued next page

● Model ZR402G Separate type Zirconia High Temperature Humidity Analyzer 2 page of 4.

	4 Calibration	1 Manual calib. (Method) 2 Semi-auto calib. (Method) 3 Abort calib. (Method) 4 Calib. constants 5 Calib. log (Method)	1 Cal zero(%) 2 Cal span(%) 3 Cell resp 4 Cell imp. 5 Cell robus
	5 Blow back	1 Start blow back (Method) 2 Abort blow back (Method)	
3 Basic setup	1 Tag 2 Configuration 3 PV range	(Method) 1 PV is 2 PV LRV 3 PV URV 4 AO added damp 5 Xfer fnctn 6 PV AO Alrm typ	
	4 SV range	1 SV is 2 SV LRV 3 SV URV 4 AO added damp 5 Xfer fnctn 6 SV AO Alrm typ	
	5 Assign TV & QV	1 TV is 2 4V is	
4 Detailed setup	1 Sensors	1 Oxygen	1 Oxygen 2 Oxygen Unit 3 Oxygen USL 4 Oxygen LSL
		2 Humidity	1 Humidity 2 Humidity Unit 3 Humidity USL 4 Humidity LSL
		3 Mixing ratio	1 Mixing 2 Mixing Unit 3 USL 4 LSL
		4 Cell temp	1 Cell temp 2 Unit 3 USL 4 LSL
		5 CJ temp	1 CJ temp 2 CJ temp Unit 3 USL 4 LSL
		6 Cell mV	1 Cell mV 2 Cell mV Unit 3 Cell mV USL 4 Cell mV LSL
		7 TC mV	1 TC mV 2 TC mV Unit 3 TC mV USL

to be continued next page

● Model ZR402G Separate type Zirconia High Temperature Humidity Analyzer 3 page of 4.

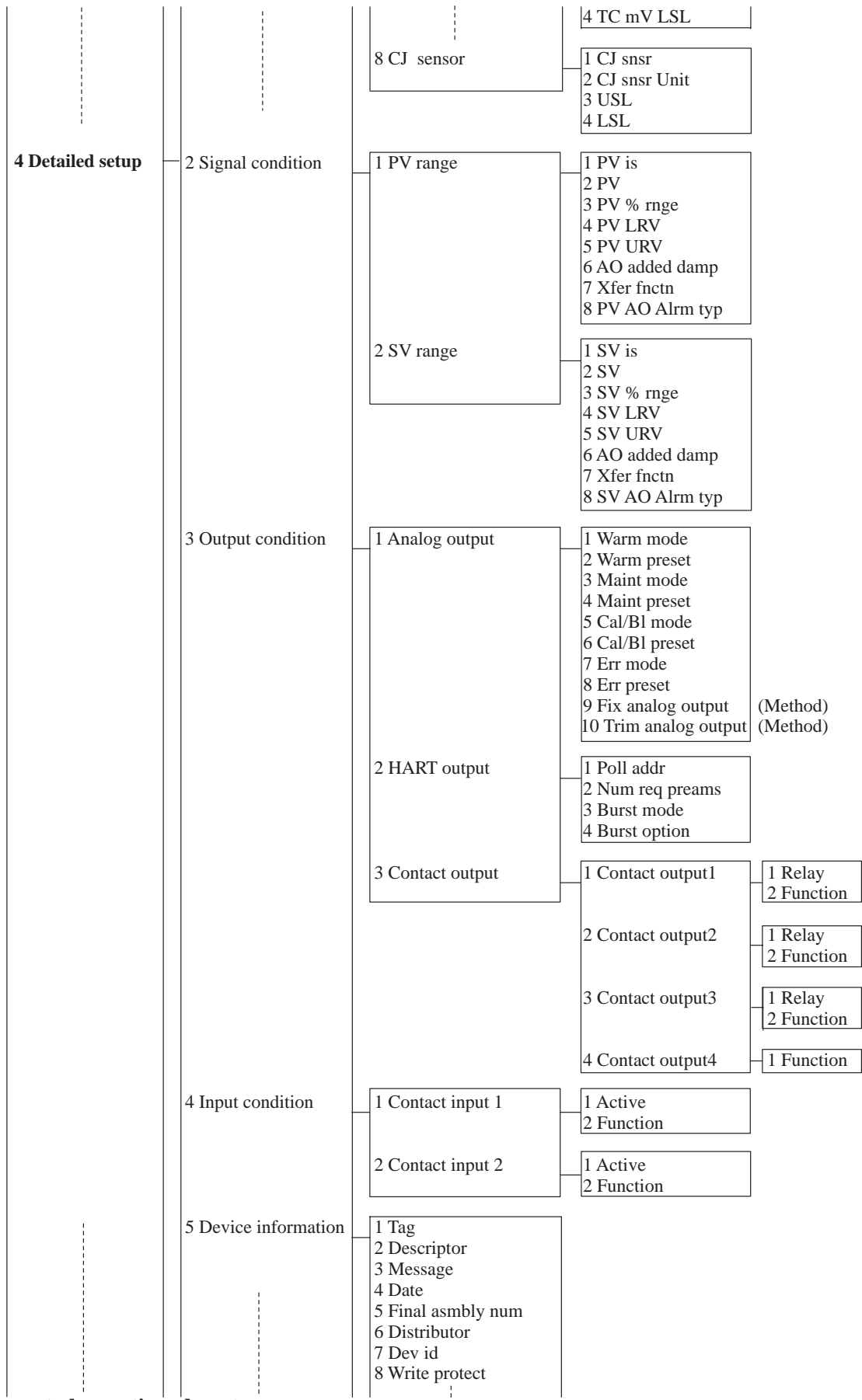

to be continued next page

● Model ZR402G Separate type Zirconia High Temperature Humidity Analyzer 4 page of 4.

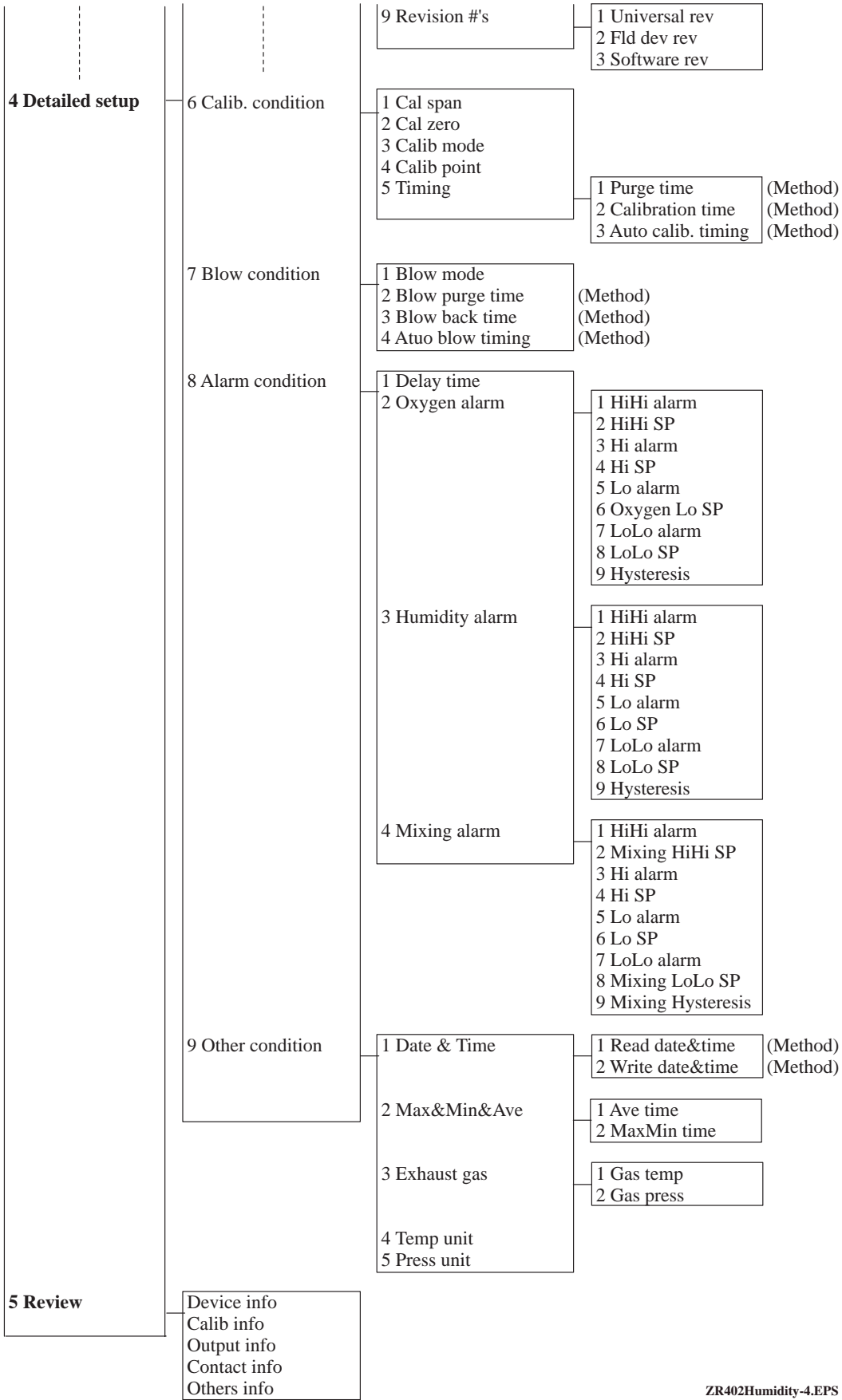

3.1.5 Menu Tree for Model ZR402G Separate type Zirconia High Temperature Humidity Analyzer with Temperature Analog input option

The Online menu summary for Model ZR402G Separate type Zirconia High Temperature Humidity Analyzer with Temperature Analog input option is shown below.

- Model ZR402G Separate type Zirconia High Temperature Humidity Analyzer with Temperature Analog input option 1 page of 5.
- Model ZR402G Separate type Zirconia High Temperature Humidity Analyzer with Temperature Analog input option 2 page of 5.
- Model ZR402G Separate type Zirconia High Temperature Humidity Analyzer with Temperature Analog input option 3 page of 5.
- Model ZR402G Separate type Zirconia High Temperature Humidity Analyzer with Temperature Analog input option 4 page of 5.
- Model ZR402G Separate type Zirconia High Temperature Humidity Analyzer with Temperature Analog input option 5 page of 5.

● Model ZR402G Separate type Zirconia High Temperature Humidity Analyzer with Temperature Analog input option 1 page of 5.

Online Menu

1 Process variables	1 View fld dev vars	1 Oxygen 2 Humidity 3 Mixing 4 Cell temp 5 CJ temp 6 AI temp		
	2 View output vars	1 View PV-AO1	1 PV is 2 PV 3 PV % rnge 4 PV AO	
		2 View SV-AO2	1 SV is 2 SV 3 SV % rnge 4 SV AO	
		3 View TV	1 TV is 2 TV	
		4 View 4V	1 4V is 2 4V	
	3 View physical vars	1 Cell mV 2 TC mV 3 CJ snsr 4 AI mA		
	4 View Max&Min&Ave	1 Oxygen Max&Min&Ave	1 Max oxygen is 2 Min oxygen is 3 Ave oxygen	(Method) (Method)
		2 Humid Max&Min&Ave	1 Max humidity is 2 Min humidity is 3 Ave humid	(Method) (Method)
		3 Mixing Max&Min&Ave	1 Max mixing is 2 Min mixing is 3 Ave mixing	(Method) (Method)
	5 View other vars	1 Temp 2 Press 3 RH% 4 Dew-P 5 Heater duty		
2 Diag/Service	1 Test device	1 Status	Status group 1 Status group 2 Status group 3 Status group 4 Status group 5 Operate mode 1	
		2 Self test 3 Master test 4 Set warning enbl	(Method) (Method) Warn enbl group1 Warn enbl group2 Warn enbl group3 Warn enbl group4	
		5 Read DI	1 DI1 2 DI2	

to be continued next page

● Model ZR402G Separate type Zirconia High Temperature Humidity Analyzer with Temperature Analog input option 2 page of 5.

		6 Test DO (Method)	
		7 Test Cal. DO (Method)	
	2 Fix analog output (Method)		
	3 Trim analog output (Method)		
	4 Calibration	1 Manual calib. (Method)	
		2 Semi-auto calib. (Method)	
		3 Abort calib. (Method)	
		4 Calib. constants	1 Cal zero(%)
			2 Cal span(%)
			3 Cell resp
			4 Cell imp.
			5 Cell robus
		5 Calib. log (Method)	
	5 Blow back	1 Start blow back (Method)	
		2 Abort blow back (Method)	
3 Basic setup	1 Tag		
	2 Configuration (Method)		
	3 PV range	1 PV is	
		2 PV LRV	
		3 PV URV	
		4 AO added damp	
		5 Xfer fnctn	
		6 PV AO Alrm typ	
	4 SV range	1 SV is	
		2 SV LRV	
		3 SV URV	
		4 AO added damp	
		5 Xfer fnctn	
		6 SV AO Alrm typ	
	5 Assign TV & QV	1 TV is	
		2 4V is	
4 Detailed setup	1 Sensors	1 Oxygen	1 Oxygen
			2 Oxygen Unit
			3 Oxygen USL
			4 Oxygen LSL
		2 Humidity	1 Humidity
			2 Humidity Unit
		3 Humidity USL	
		4 Humidity LSL	
	3 Mixing ratio	1 Mixing	
		2 Mixing Unit	
		3 USL	
		4 LSL	
	4 Cell temp	1 Cell temp	
		2 Unit	
		3 USL	
		4 LSL	
	5 CJ temp	1 CJ temp	
		2 CJ temp Unit	
		3 USL	
		4 LSL	
	6 AI temp	1 AI temp	

to be continued next page

ZR402HumidityAI-2.EPS

● Model ZR402G Separate type Zirconia High Temperature Humidity Analyzer with Temperature Analog input option 3 page of 5.

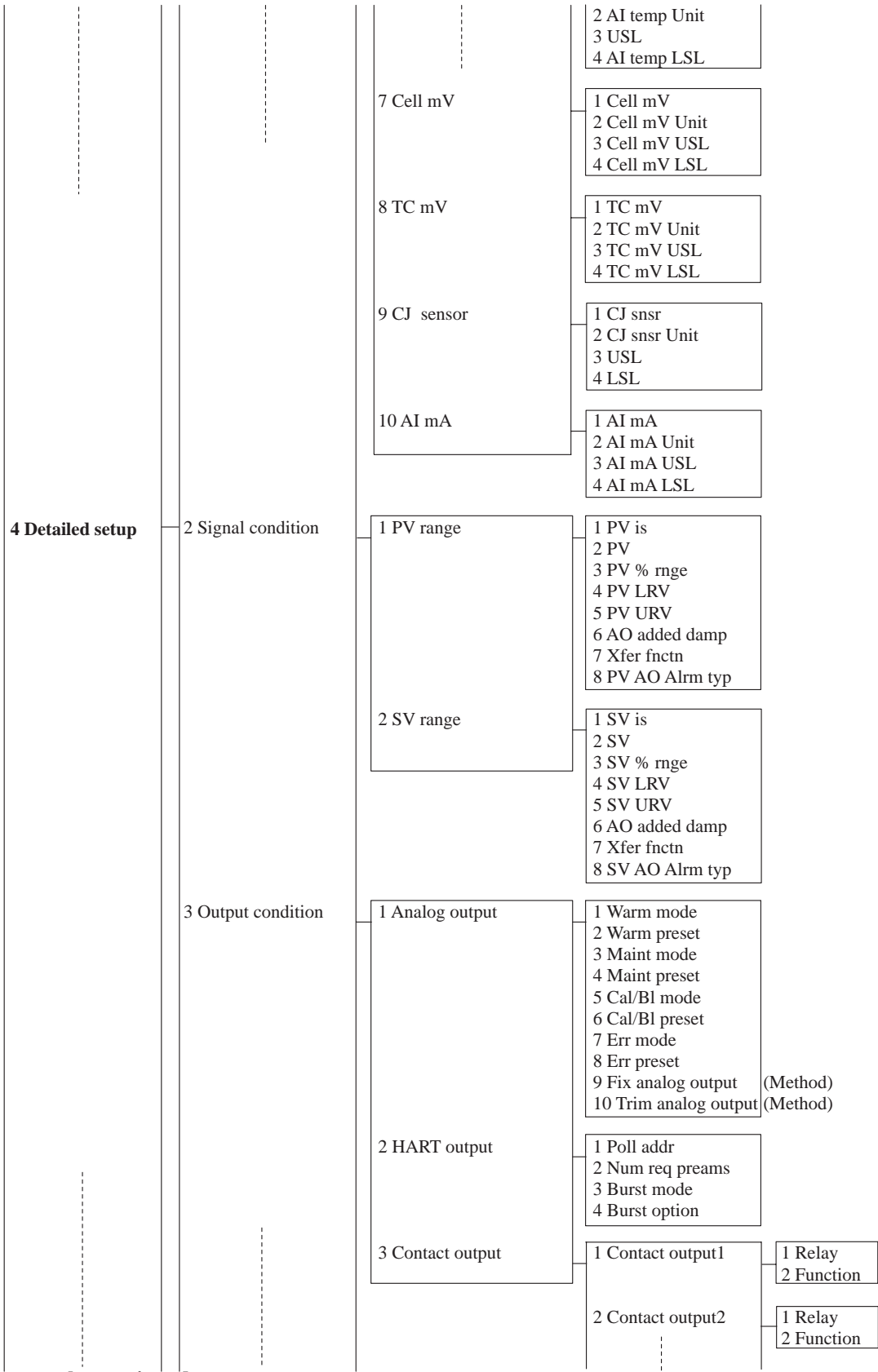

to be continued next page

ZR402HumidityAI-3.EPS

● Model ZR402G Separate type Zirconia High Temperature Humidity Analyzer with Temperature Analog input option 4 page of 5.

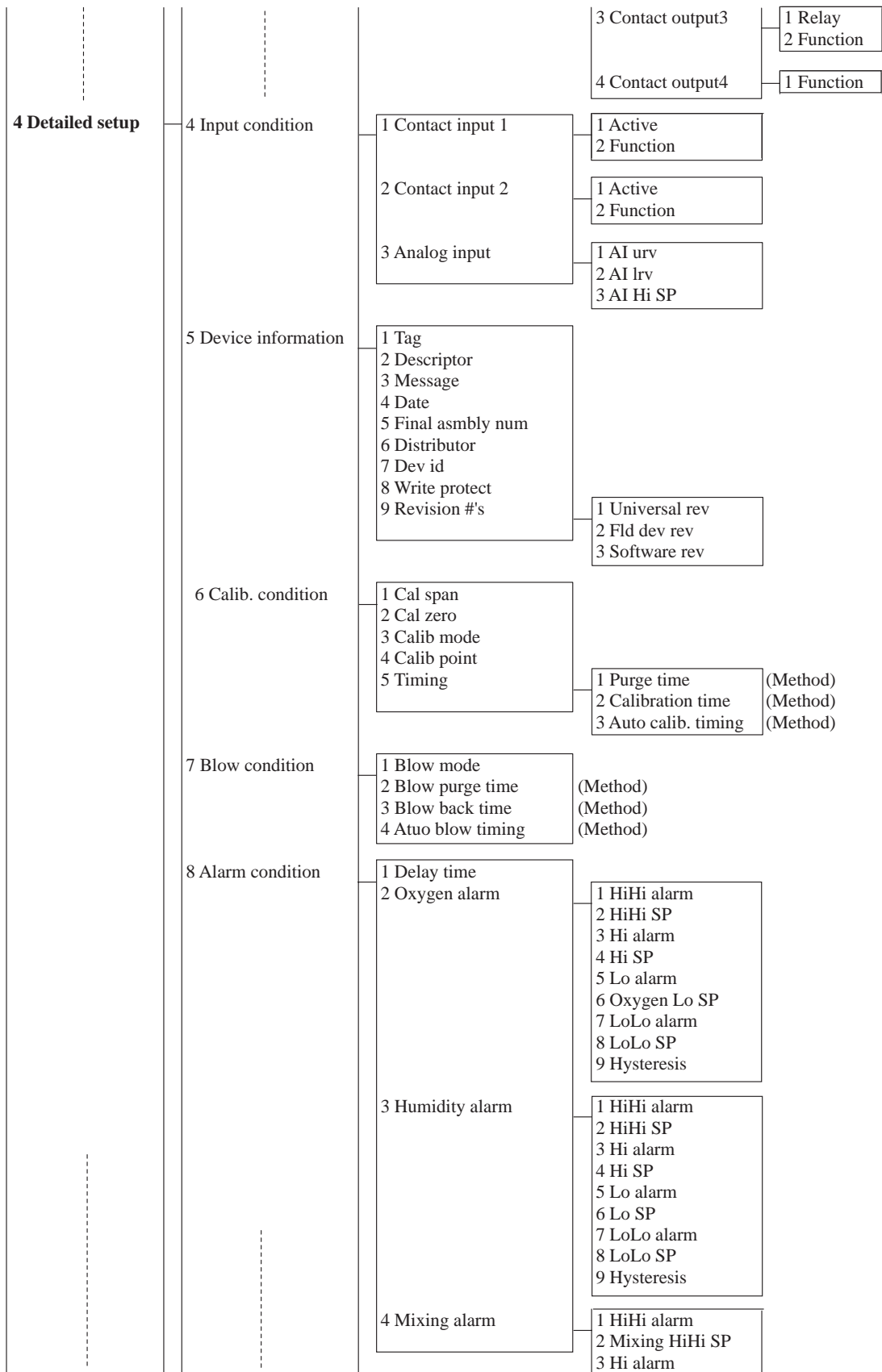

to be continued next page

ZR402HumidityAI-4.EPS

● Model ZR402G Separate type Zirconia High Temperature Humidity Analyzer with Temperature Analog input option 5 page of 5.

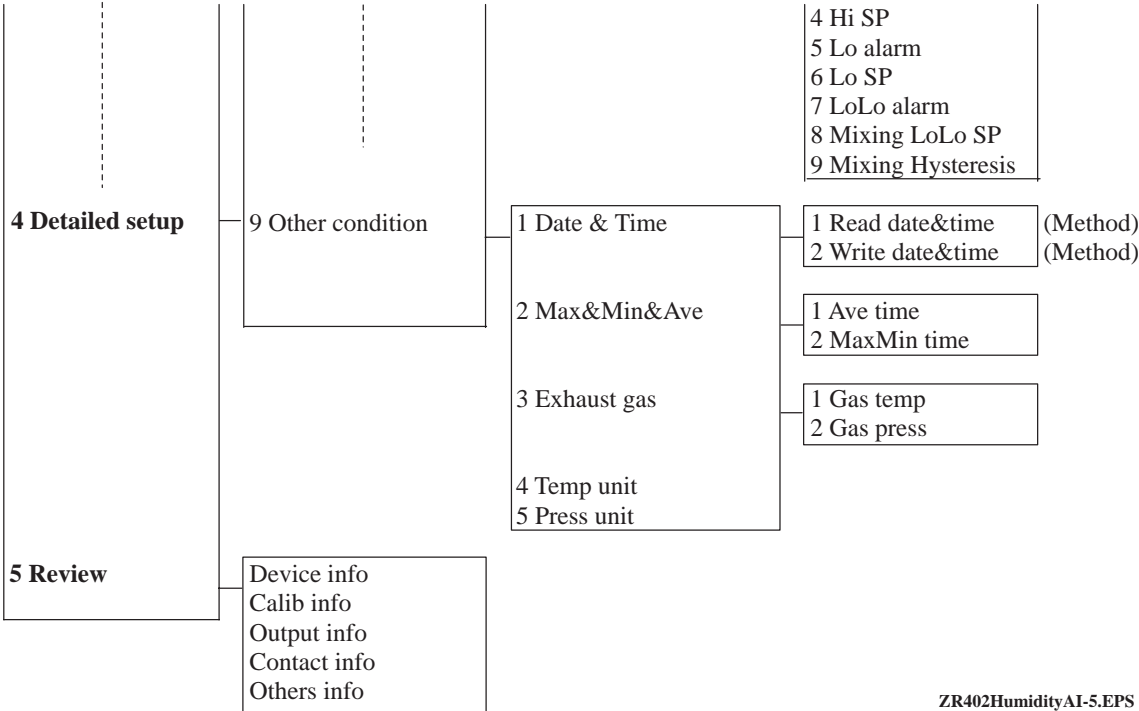

ZR402HumidityAI-5.EPS

3.2 Setting Parameters

(1) PV selection

(Refer to Section 8.1, "Current Output Setting," in the ZR202G Instruction Manual.)

(Refer to Section 8.1, "Current Output Setting," in the ZR402G Instruction Manual.)



NOTE

For the oxygen analyzer, the PV (Analog Output 1) is for oxygen concentration (fixed), so parameter setting is not required.

Call up "PV range" display.

ZR202G

1.Device setup ---> 3.Basic setup ---> 3.PV range

ZR402G

3.Basic setup ---> 3.PV range

	Display	Operation
1		Select "PV is".
2		Press OK (F4) . (OK)
3		Press OK (F4) . (OK)
4		Select the desired item for the PV (Analog Output 1). An example of selecting item "3" (Mixing ratio.) is shown on the left. The ZR202G and ZR402G outputs change.

F030201.EPS

(2) PV LRV input

(Refer to Section 8.1.1, "Minimum/Maximum Setting," in the ZR202G Instruction Manual.)

(Refer to Section 8.1.1, "Minimum/Maximum Setting," in the ZR402G Instruction Manual.)

Example: To set PV LRV for 10%

Set "PV URV", "SV LRV" and "SV URV" using the same procedures as the following as required. For the ZR202G, no SV-range settings are required.







Call up "PV range" display.

ZR202G

1.Device setup ---> 3.Basic setup ---> 3.PV range

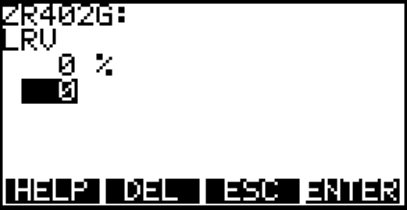
ZR402G

3.Basic setup ---> 3.PV range

	Display	Operation	
1			Select "PV LRV".
2		'10'  (ENTER)	Enter "10" and press ENTER (F4).
3		 (SEND)	Press SEND (F2).

F030202.EPS

(3) Calibration condition setting

(Refer to Section 9.2.1, "Calibration Setting," in the ZR202G Instruction Manual.)

(Refer to Section 9.2.1, "Calibration Setting," in the ZR402G Instruction Manual.)

Set parameters to carry out calibration.

Example: To set the zero gas concentration at 0.98% O₂, the calibration mode to automatic calibration, and the "purge time" to five minutes

Set other items as necessary.

Call up "Calib. condition" display.

ZR202G











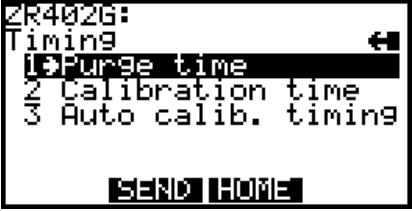

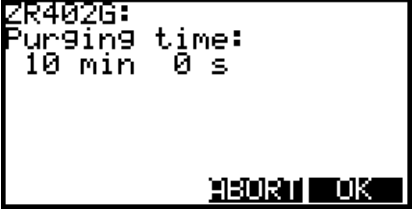
1.Device setup ---> 4.Detailed setup ---> 6.Calib. condition

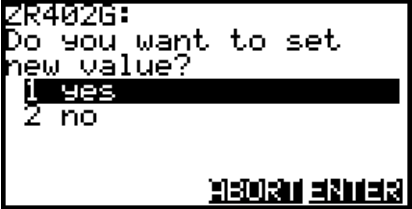
ZR402G

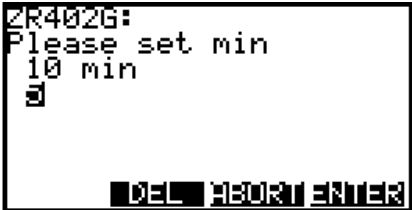
5.Detailed setup ---> 6.Calib. condition

	Display	Operation	
1	<pre>ZR402G: Calib. condition ← 1 Cal span 21.00 % 2 Cal zero 1.00 % 3 Calib mode Manual 4 Calib point Both 5 Timing HELP SEND HOME</pre>	<div style="border: 1px solid black; padding: 5px; width: 40px; margin: 0 auto;">VWX 2</div>	Set the zero gas concentration. Select "Cal zero".
2	<pre>ZR402G: Cal zero 1.00 % 0.98</pre>	<div style="border: 1px solid black; padding: 5px; width: 40px; margin: 0 auto;">F1</div> <p>(ENTER)</p>	Enter "0.98" and press ENTER (F4) .
3	<pre>ZR402G: Calib. condition ← 1 Cal span 21.00 % 2 Cal zero 0.98 % 3 Calib mode Manual 4 Calib point Both 5 Timing HELP SEND HOME</pre>	<div style="border: 1px solid black; padding: 5px; width: 40px; margin: 0 auto;">YZ/ 3</div>	Set the calibration mode. Select "Calib mode".
4	<pre>ZR402G: Calib mode Manual Manual Semi-Auto Auto</pre>	<div style="display: flex; justify-content: center; align-items: center; gap: 10px;"> <div style="border: 1px solid black; padding: 5px; width: 40px; height: 40px; text-align: center; line-height: 40px;">↓</div> <div style="border: 1px solid black; padding: 5px; width: 40px; height: 40px; text-align: center; line-height: 40px;">F4</div> </div> <p>(ENTER)</p>	Select "Auto" and press ENTER (F4) .
5	<pre>ZR402G: Calib. condition ← 1 Cal span 21.00 % 2 Cal zero 0.98 % 3 Calib mode Auto 4 Calib point Both 5 Timing</pre>	<div style="border: 1px solid black; padding: 5px; width: 40px; margin: 0 auto;">MNO 5</div>	Select "Timing".

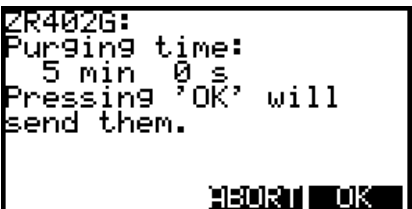
to be continued next page

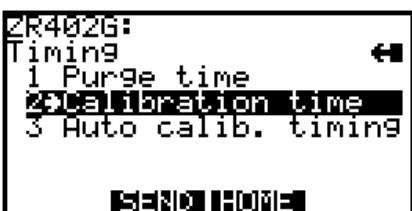
- 6   Set the purge time.
Select "Purge time".
- 7   Press **OK (F4)**.
- 8   Select "Yes".
- 9  '5'  Enter "5" and press **ENTER (F4)**.
(ENTER)
- 10   Press **ENTER (F4)**.
(ENTER)
- 11   Press **OK (F4)**.
(OK)
- 12 

(4) Blow back condition setting

(The ZR202G does not have this function.)

(Refer to Section 10.2.1, "Blow back Setup," in the ZR402G Instruction Manual.)

Set parameters to carry out blowback.











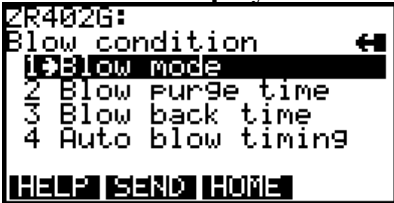

Example: To set the mode to automatic and the starting date to June 21, 2000

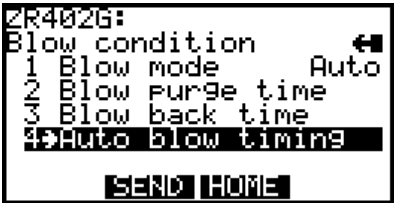
Set other items as necessary

Call up "**Blow condition**" display.

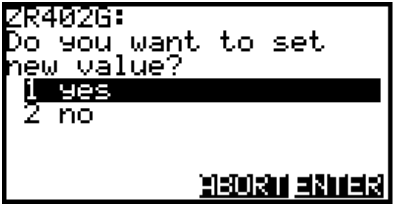
ZR402G

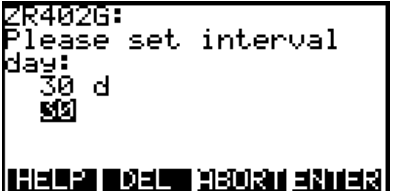
5.Detailed setup ---> 7.Blow condition

	Display	Operation	
1			Set the blow back mode. Select " Blow mode ".
2		  (ENTER)	Select " Auto " and press ENTER (F4).
3			Set the automatic blow back timing. Select " Auto blow timing ".
4		 (OK)	Press OK (F4).
5			Select " Yes ".
6		 (ENTER)	Press ENTER (F4).

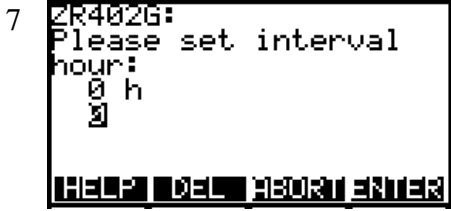

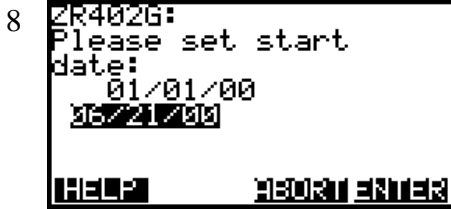

(ENTER)

Press **ENTER (F4)**.

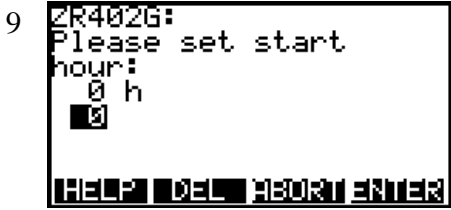

'062100' 
(ENTER)

Enter month/day/year with two digits for each. For example, enter "**062100**" for June 21, 2000. Press **ENTER (F4)**



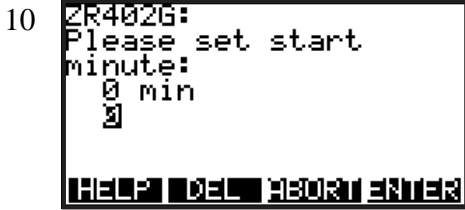

(ENTER)

Press **ENTER (F4)**.



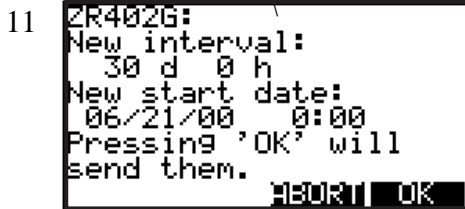

(ENTER)

Press **ENTER (F4)**.

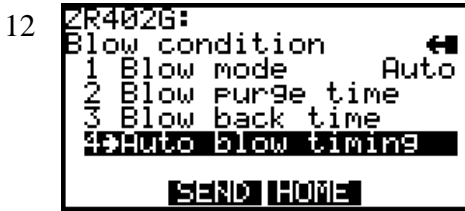

(OK)

New settings will appear on the display. Press **OK (F4)**



F030206.EPS

(5) Trim Analog Output

The following shows analog-output adjustment procedures.

Example: To trim PV (Analog Output 1)

Call up the "Blow condition" display.

ZR202G

1.Device setup ---> 2.Diag / Service ---> 3.D/A Trim

ZR402G

2.Diag / Service ---> 3.Trim analog output

	Display	Operation	
1	<pre>ZR402G: WARN-Loop should be removed from automatic control ABORT OK</pre>	<div style="border: 1px solid black; width: 30px; height: 30px; margin: 0 auto; display: flex; align-items: center; justify-content: center;">F4</div> (OK)	Press OK (F4) .
2	<pre>ZR402G: Connect reference meter ABORT OK</pre>	<div style="border: 1px solid black; width: 30px; height: 30px; margin: 0 auto; display: flex; align-items: center; justify-content: center;">F4</div> (OK)	Connect the ammeter (± 1 μA is measurable), and press OK (F4) .
3	<pre>ZR402G: Select analog output to trim PV 50 50 ABORT ENTER</pre>	<div style="border: 1px solid black; width: 30px; height: 30px; margin: 0 auto; display: flex; align-items: center; justify-content: center;">F4</div> (ENTER)	Select "PV" and press ENTER (F4) . This display does not appear when using the ZR202G.
4	<pre>ZR402G: Select analog output units mA EXIT</pre>	<div style="border: 1px solid black; width: 30px; height: 30px; margin: 0 auto; display: flex; align-items: center; justify-content: center;">F4</div> (EXIT)	Press EXIT (F4) . This display does not appear when using the ZR202G.
5	<div style="border: 1px solid black; padding: 5px; width: 45%;"> <pre>ZR202G Setting fld dev output to 4mA ABORT OK</pre> </div> <div style="border: 1px solid black; padding: 5px; width: 45%;"> <pre>ZR402G About to set fld dev output to 4.00 mA ABORT OK</pre> </div>	<div style="border: 1px solid black; width: 30px; height: 30px; margin: 0 auto; display: flex; align-items: center; justify-content: center;">F4</div> (OK)	Press OK (F4) , and ZR202G / ZR402G outputs the output signal of 0%.
6	<pre>ZR402G: Enter meter value 4.002 HELP DEL ABORT ENTER</pre>	"4.002" <div style="border: 1px solid black; width: 30px; height: 30px; margin: 0 auto; display: flex; align-items: center; justify-content: center;">F4</div> (OK)	<div style="border: 2px solid black; padding: 5px; display: inline-block; margin-bottom: 5px;">Ammeter reading: 4.002</div> Enter the read value 4.002 of the ammeter, and press ENTER (F4) . (The output of ZR202G / ZR402G changes.)

F030207.EPS

to be continued next page

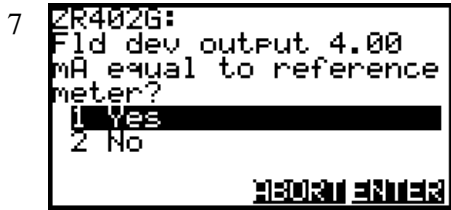

F4
(ENTER)

Ammeter reading: 4.000

Because the reading on the ammeter is 4.000 mA, select YES and press **ENTER (F4)** . If the reading is not 4.000 mA, select item **2. NO** . Repeat steps 5 and 6 until the ammeter reads 4.000mA.

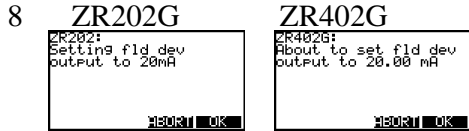

F4
(ENTER)

Press **OK (F4)** , and ZR202G / ZR402G output signal of 100%.



"199.998"
F4
(ENTER)

Ammeter reading: 19.998
Carry out the same procedures as those described under 5 and 6.

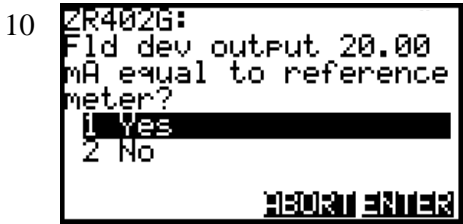

F4
(ENTER)

Ammeter reading: 20.000
Returning fld dev to original output appears.

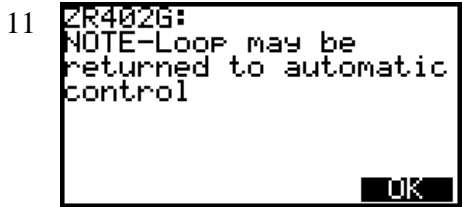

F4
(OK)

Press **OK (F4)**.

(6) Burst Mode

The ZR202G / ZR402G continuously sends the data stored in it when the burst mode is set "On". Either one of measured value, % output value, or 4 to 20 mA output value can be selected and sent. The data is sent intermittently as a digital signal at 75 ms intervals when the ZR202G / ZR402G is set in the burst mode. Therefore, communication by the HART simultaneous communicator is also possible.

Setting of Burst Mode

Call up "Burst option" display.

ZR202G

- 1.Device setup ---> 4.Detailed setup ---> 3.Output condition --->
- 2.HART output ---> 4.Burst option

ZR402G

- 4.Detailed setup ---> 3.Output condition ---> 2.HART output --->
- 4.Burst option

Display

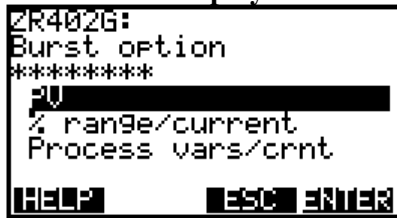

Operation

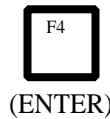

- Set data to be sent.
- Measured value (PV)
 - % output value (% range/current)
 - 4 to 20 mA output value (Process vars /crnt)

Call up "Burst mode" display.

3.HART output → 3.Burst mode

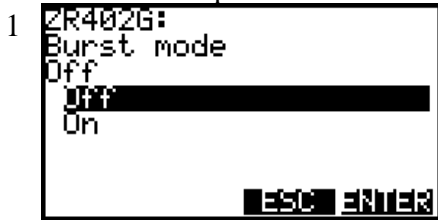

Set "On" and press **ENTER (F4)**.

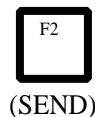
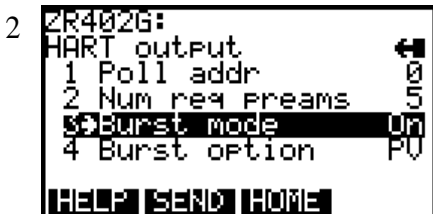

Press **SEND (F2)**.



Select "Configure Communication".

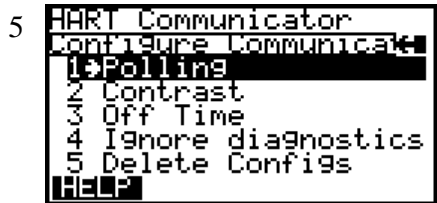

Select "Polling".

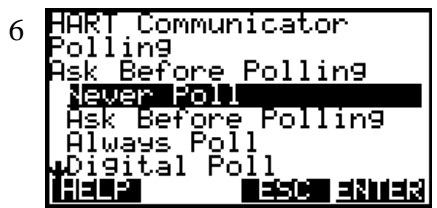

×3



(ENTER)

Select "Digital Poll" and press ENTER (F4).

F030212.EPS



NOTE

1. If "Never Poll" is set in "Polling" when the address is set "Online Menu" cannot be called up and displayed. Be sure to set "Digital Poll" in "Polling" after setting the polling address.
2. When the same polling address is set for two or more field devices in multidrop mode, communication with these field devices is disabled.

Example: Communication when set in the multidrop mode.

Display



Operation

(1) The HART Communicator searches for the field device is set in the multidrop mode when the HART Communicator is turned on. When the HART Communicator is connected to the field device, the tag will be displayed (display 1).



(2) Select desired field device. After that, normal communication with the selected field device is possible. However, the communication speed is slow in this case (display 2).

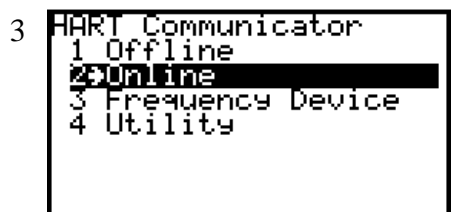

(3) To communicate with another field device, call up display 3, and select "Online".

(4) Display 1 will appear. Repeat the above operation.

F030213.EPS

Releasing from Multidrop Mode

First, call up the "Poll addr" display, and set the address to 0.

Second, call up the "Polling" display, and set "Never Poll".

	NOTE	If the above releasing method is carried out in the reverse order "Online Menu" can not be called up.
---	-------------	---

(8) Software Write Protect

ZR202G/ZR402G configured data is saved by the write protect function. Write protect status is set to YES when 8 alphanumeric characters are entered in the New password field and transferred to the ZR202G/ZR402G. In write protect YES status, the transmitter ZR202G/ZR402G does not accept parameter changes. When the 8 alphanumeric string entered in the New password field is also entered in the Enable write field and transferred to the transmitter, it will be possible to change transmitter parameters during a 10 minute period.









To change the transmitter from Write protect YES status back to Write protect NO status, enter 8 spaces in the New password field after Write protect has been released using enable write.

Setting Password

Example: Set the password to 1234

Call up "Chng Wrt protect" display.

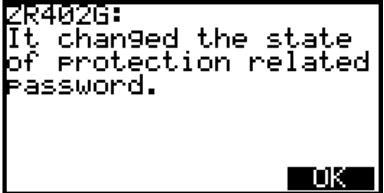
Hot key ---> 2.chng Wrt protect

Display	Operation	
<p>1</p> 		Select the "New password".
<p>2</p> 	<p>'1 2 3 4'</p>  (ENTER)	Set "1234" and press ENTER (F4).
<p>3</p> 	<p>"1 2 3 4"</p>  (ENTER)	Reenter "1234" and press ENTER (F4) within 30 seconds.
<p>4</p> 	 (OK)	

F030215.EPS

to be continued next page

5

```
ZR402G:
Chng Wrt Protect  ←
1 Write protect Yes
2 Enable wrt 10min
3 New Password
4 Software seal Keep

SAVE
```







F030216.EPS

Changing Password

Example: To change the password from 1234 to 6789A

Call up "Chng Wrt protect" display.

Hot key ---> 2.chng Wrt protect

Display	Operation	
<p>1</p> <pre>ZR402G: Chng Wrt Protect ← 1 Write protect Yes 2 Enable wrt 10min 3 New Password 4 Software seal Keep SAVE</pre>		<p>Select the "Enable wrt 10min".</p>
<p>2</p> <pre>ZR402G: Enter current Password to enable to write for 10 minutes: 1234 DEL REOR ENTER</pre>	<p>' 1 2 3 4 '</p>  <p>(ENTER)</p>	<p>Set the old password "1234" and press ENTER (F4).</p>
<p>3</p> <pre>ZR402G: Released the write protection for 10 minutes. REOR OK</pre>	 <p>(OK)</p>	<p>Press OK (F4).</p>
<p>4</p> <pre>ZR402G: If you want to release completely, you have to change password to all of spaces. REOR OK</pre>	 <p>(OK)</p>	<p>Press OK (F4).</p>
<p>5</p> <pre>ZR402G: Chng Wrt Protect ← 1 Write protect No 2 Enable wrt 10min 3 New Password 4 Software seal Keep SAVE</pre>		<p>Select the "New password".</p>
<p>6</p> <pre>ZR402G: Enter new password to change state of write protect: 6789A DEL REOR ENTER</pre>	<p>"6789A"</p>  <p>(ENTER)</p>	<p>Set new password "6789A" and press ENTER (F4).</p>
<p>7</p> <pre>ZR402G: Re-enter new password within 30 seconds: 6789A DEL REOR ENTER</pre>	<p>"6789A"</p>  <p>(ENTER)</p>	<p>Reenter new password "6789A" and press ENTER (F4).</p>

to be continued next page

8

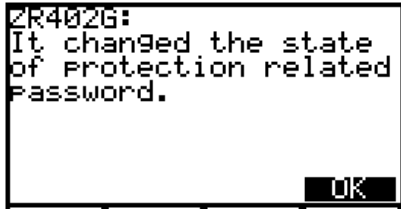

(OK)

Press **OK (F4)**.

F030219.EPS



NOTE

1. Enable Wrt 10 min releases Write Protect status for 10 minutes. While Write Protect status is released, enter a new password in the New Password field. It will not be possible to set a new password when 10 minutes have elapsed.
2. To release Write Protect status completely, enter 8 spaces in the New Password field according to the instructions given in Changing the Password. This causes Write Protect status to change from YES to NO.

"Joker password" and "Software Seal"

When you forget the password that has been registered, it is possible to release the mode for 10 minutes by using a joker password. Enter YOKOGAWA to release Write protect status for 10 minutes. If this joker password is used, the status shown in the parameter "Software seal" is changed from "Keep" to "Break" Press Hot key and select "2. Wrt Protect menu". Current status is shown m "4 Software seal". This status will be returned from "Break" to "Keep" by registering a new password.

(9) Hardware Write Protect

This function prohibits parameter changes through a slide switch on a Main board assembly. In the case the hardware write protection switch is set to YES, none of the communication method including the handheld terminal such as model 275 is allowed for the alteration of parameters. The write protection switch is factory set to NO (L position in the figure below).

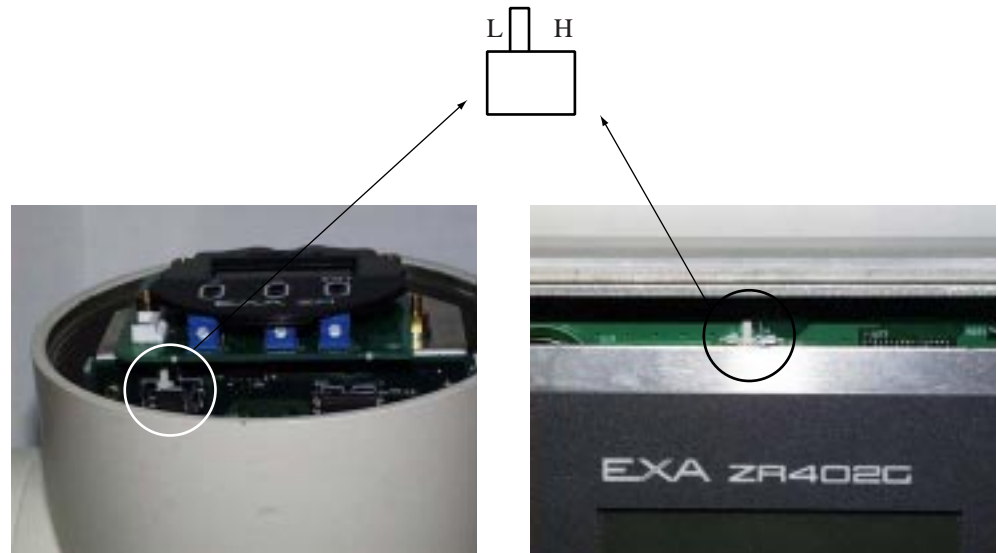

ZR202G

ZR402G

F030220.EPS

Switch position	Write protection
L	NO
H	YES

T030201.EPS

3.3 Calibration

(Refer to Chapter 9, "Calibration," in the ZR202G Instruction Manual.)

(Refer to Chapter 9, "Calibration," in the ZR402G Instruction Manual.)

The following shows manual calibration procedures using the HART communicator.

Call up "Calibration" display.

Hot key ---> 1.Calibration ---> 1.Manual Calib

	Display	Operation	
1			Select the "Span".
2			Check the span gas concentration and press OK (F4) .
3			To change the span gas concentration, select "Yes" then set a new value. If you do not want to change the value, select "No." An example of selecting "No" is shown on the left.
4			Flow the specified span gas, then press OK (F4) . When the automatic calibration unit is connected, the solenoid valve for the span gas will be opened automatically.
5			The O ₂ value will be updated when you select the "Update o ₂ value". Select "Cal done" after the o ₂ -value reading has stabilized.
6			Select the "Zero".

F030301.EPS

to be continued next page

- | | | | |
|----|--|---|--|
| 7 | <pre>ZR402G: Check the zero gas concentration. Zero gas conc.: 1.00 % HEORTI OK</pre> | <div style="border: 1px solid black; padding: 2px; display: inline-block; text-align: center;">F4</div>
(OK) | <p>Check the zero gas concentration and press OK (F4).</p> |
| 8 | <pre>ZR402G: Do you want to set new value?: 1 Yes 2 No HEORTI ENTER</pre> | <div style="border: 1px solid black; padding: 2px; display: inline-block; text-align: center;">STU
1</div> | <p>To change the zero gas concentration, press "Yes" and set a new value. If you do not want to change the value, select "No".</p> |
| 9 | <pre>ZR402G: Please open zero gas valve. Set the flow of zero gas to 500ml/min HEORTI OK</pre> | <div style="border: 1px solid black; padding: 2px; display: inline-block; text-align: center;">F4</div>
(OK) | <p>Flow the specified zero gas, then press OK (F4). When the automatic calibration unit is connected, the solenoid valve for the zero gas will be opened automatically.</p> |
| 10 | <pre>ZR402G: o2 value: 1.00 % 1 Update o2 value 2 Cal done 3 Abort cal HEORTI ENTER</pre> | <div style="border: 1px solid black; padding: 2px; display: inline-block; text-align: center;">VWX
2</div> | <p>The o2 value will be updated when you select the "Update o2 value". Select "Cal done" after the o2-value reading has stabilized.</p> |
| 11 | <pre>ZR402G: Please wait Purge time 5 min 0 s HEORTI OK</pre> | <div style="border: 1px solid black; padding: 2px; display: inline-block; text-align: center;">F4</div>
(OK) | <p>Calibration is complete and the purge time begins.</p> |
| 12 | <pre>ZR402G: Calibration ← 1 Manual calib. 2 Semi-auto calib. 3 Abort calib. 4 Calib. constants 5 Calib. log HELP SAVE</pre> | <div style="border: 1px solid black; padding: 2px; display: inline-block; text-align: center;">YZ/
3</div> | <p>To cancel the Purge time, select "Abort calib.".</p> |
| 13 | <pre>ZR402G: Do you want to cancel purge time: 1 yes 2 no HEORTI ENTER</pre> | <div style="border: 1px solid black; padding: 2px; display: inline-block; text-align: center;">STU
1</div> | <p>When you press "Yes", the purge time is canceled</p> |

F030302.EPS

3.4 Blow back (ZR402G only)







(The ZR202G does not have this function.)

(Refer to Section 10.2, "Blow back," in the ZR402G Instruction Manual.)

The following shows the blow-back procedure with the HART communicator. Blow back is carried out only when semi-auto is selected in the Blow back mode and one of the contact outputs is set for the blow back function. Refer to Section 4.2, "Blow back," in the Instruction Manual for more details. The ZR202G does not have the blow back function.

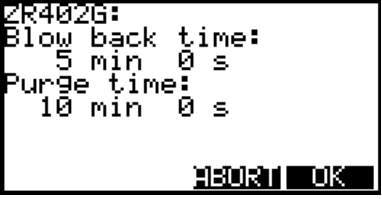
Call up "Blow back" display.

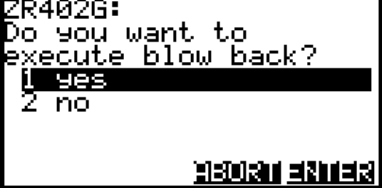
2.Diag / Service ---> 5.Blow back

	Display	Operation
1		 Select the "Start blow back".
2		 Check the Blow back time and Purge time, and press OK (F4) .
3		 Select "Yes" and press ENTER (F4) . Blow back will start.

F030401.EPS

3.5 Self Diagnostics

Self-diagnostics of the transmitter and check of incorrect data setting can be carried out with the HART communicator. There are two methods for self-diagnosis of the transmitter, self-diagnosis for every transmission and manually executing the SELF TEST command. When an error message appears, follow "ERROR MESSAGES".

For ERROR and ALARM messages, and troubleshooting procedures, refer to Chapter 12, "Troubleshooting" of the ZR202G/ZR402G Instruction Manual.







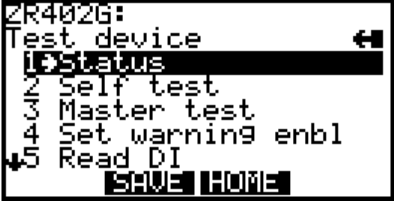

Dagnostic by "Self test"

ZR202G

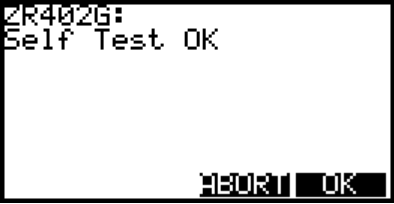
1.Device setup ---> 2.Diag / Service ---> 1.Test device

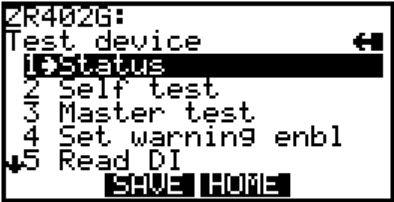
ZR402G

2.Diag / Service ---> 1.Test device

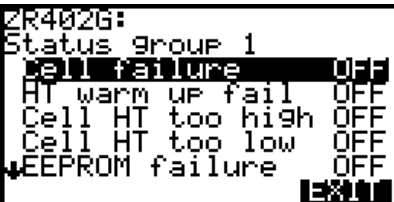
	Display	Operation	
1			Select the "Self test".
2		 (OK)	If there is no error detected, "Self test OK" will be displayed. Press OK (F4). When an error occurs, an error message appears and the results of self-diagnostics appear in the "Status".
3			Call up "Status".
4			The status menu is separated 5 groups. About items of each group, see "Alarm/Error Messages and Display on the Analyzer".
5			Select the desired group. If there is no error, the result of diagnostics is indicated as "OFF". If "ON" is indicated, a countermeasure for that error is necessary.

F030501.EPS

Table 3.1 Alarm/Error Messages and Analyzer Display

	Display on the HART Communicator	Detail	ZR202G Display	ZR402G Display
Group 1	Cell failure	Abnormal cell voltage	Err-01	Error 1
	HT warm up fail	Temperature does not rise enough during warming up.	Err-02	Error 2
	Cell HT too high	Detector heater temperature exceeds high-limit.	Err-02	Error 2
	Cell HT too low	Detector heater temperature falls below low-limit.	Err-02	Error 2
	EEPROM failure	Abnormal memory in the electrical circuit.	Err-03	Error 3
Group 2	ADC failure	Abnormal AD converter in the electrical circuit.	Err-04	Error 4
	Excess input TC	Thermocouple voltage exceeds the input range.	AL-11	Alarm 11
	Excess input CJ	The input signal from the cold junction exceeds the input range.	AL-10	Alarm 10
	Excess input AI	The input signal from the temperature transmitter is out of the input range.	*Note 1	Alarm 12
	CJ temp too high	Cold junction temperature exceeds high-limit.	AL-10	Alarm 10
	CJ temp too low	Cold junction temperature falls below low-limit.	AL-10	Alarm 10
Group 3	Low battery	Backup battery voltage is low.		
	Cal. zero error	Zero-point compensation ratio is outside normal range.	AL-06	Alarm 6
	Cal. span error	Span compensation ratio is outside normal range.	AL-07	Alarm 7
	Cal. stabl error	Cell voltage is not stable during calibration.	AL-08	Alarm 8
Group 4	Cell Imp too high	The cell impedance exceeds 10 kΩ.		
	AO is holding	Analog Output is holding.		
	AO1 is testing	Analog Output 1 is loop testing.		
Group 5	AO2 is testing	Analog Output 2 is loop testing.	*Note 1	
	Cal. gas too low	Calibration gas pressure signal is input to contact input.		
Group 5	Changing AO range	Range changing signal is input to contact input.		
	Process gas fail	Process gas fail signal is input to contact input.		
	DO1 is active	Active Contact Output 1.		
	DO2 is active	Active Contact Output 2.		
	DO3 is active	Active Contact Output 3.	*Note 1	
	DO4 is active	Active Contact Output 4.	*Note 1	

Note 1: The ZR202G does not have these functions.

T030501.eps

4. Maintenance

4.1 Test Output

(Refer to Section 7.8, "Checking Current Loop," in the ZR202G Instruction Manual.)

(Refer to Section 7.10, "Checking Current Loop," in the ZR402G Instruction Manual.)

Example: To output 12mA for Analog Output 1

Call up "**Fix analog output**" display.

ZR202G

1.Device setup ---> 2.Diag / Service ---> 2.Loop test

ZR402G

2.Diag / Service ---> 2.Fix analog output

	Display	Operation	
1	<pre>ZR402G: WARN-Loop should be removed from automatic control HELP OK</pre>	<div style="border: 1px solid black; width: 30px; height: 30px; margin: 0 auto; display: flex; align-items: center; justify-content: center;">F4</div> <p>(OK)</p>	<p>Press OK (F4).</p> <p>When using ZR202G, press ENTER (F4) to skip to display 4 below.</p>
2	<pre>ZR402G: Select analog output to trim SU PV SU HELP ENTER</pre>	<div style="border: 1px solid black; width: 30px; height: 30px; margin: 0 auto; display: flex; align-items: center; justify-content: center;">F4</div> <p>(OK)</p>	<p>Select an analog output to trim. An example of selecting PV (Analog Output 1) is shown on the left.</p>
3	<pre>ZR402G: Select analog output units mA EXIT</pre>	<div style="border: 1px solid black; width: 30px; height: 30px; margin: 0 auto; display: flex; align-items: center; justify-content: center;">F4</div> <p>(EXIT)</p>	<p>Press EXIT (F4).</p>
4	<pre>ZR402G: Choose analog output level 1 4mA 2 20mA 3 Other 4 End HELP ENTER</pre>	<div style="border: 1px solid black; width: 30px; height: 30px; margin: 0 auto; display: flex; align-items: center; justify-content: center;">YZ/3</div>	<p>Select "3.Other".</p>
5	<pre>ZR402G: Enter desired analog output value 12 HELP DEL ABORT ENTER</pre>	<p>'12'</p> <div style="border: 1px solid black; width: 30px; height: 30px; margin: 0 auto; display: flex; align-items: center; justify-content: center;">F4</div> <p>(ENTER)</p>	<p>Enter "12" and press ENTER (F4).</p>
6	<pre>ZR402G: Field dev PV A0 is fixed at 12.00 mA HELP OK</pre>	<div style="border: 1px solid black; width: 30px; height: 30px; margin: 0 auto; display: flex; align-items: center; justify-content: center;">F4</div> <p>(OK)</p>	<p>A 12-mA output is provided. Press OK (F4) to return the analog output to its original value.</p>

F040101.EPS

4.2 Read DI

(Refer to Section 7.9, "Checking Contact I/O" in the ZR202G Instruction Manual.)

(Refer to Section 7.11, "Checking Contact I/O" in the ZR402G Instruction Manual.)

The following shows the procedures for checking the input contact open/closed status.

Call up "**Read DI**" display.

ZR202G

1.Device setup ---> 2.Diag / Service ---> 1.Test device ---> 5.Read DI

ZR402G

2.Diag / Service ---> 1.Test device ---> 5.Read DI

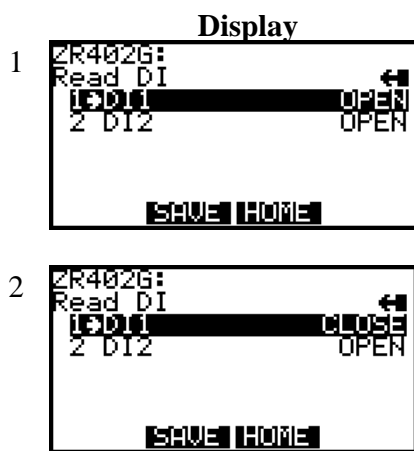

Operation

Both Input Contact 1 and 2 are "Open".

When you close Input Contact 1, the display changes to indicate that DI1 is "Closed".

F040201.EPS

4.3 Test DO

The following shows the procedures for checking the output contact open/closed status.

(Refer to Section 7.9, "Checking Contact I/O" in the ZR202 Instruction Manual.)

(Refer to Section 7.11, "Checking Contact I/O" in the ZR402G Instruction Manual.)

Prior to carrying out this test, refer to the Contact Check section in the Instruction Manual.

Call up "Test DO" display.

ZR202G

1.Device setup ---> 2.Diag / Service ---> 1.Test device ---> 6.Test DO

ZR402G

2.Diag / Service ---> 1.Test device ---> 6.Test DO

	Display	Operation	
1	<pre>ZR402G: WARN-Loop should be removed from automatic control ABORT OK</pre>	<div style="border: 1px solid black; width: 30px; height: 30px; display: flex; align-items: center; justify-content: center; margin: 0 auto;">F4</div> (OK)	Press OK (F4) .
2	<pre>ZR402G: Test DO: 1 DO1 2 DO2 3 DO3 4 DO4 5 Exit ABORT ENTER</pre>	<div style="border: 1px solid black; width: 30px; height: 30px; display: flex; align-items: center; justify-content: center; margin: 0 auto;">F4</div> (ENTER)	Select an Output Contact to be tested. An example of selecting DO1 is shown on the left. After selecting the Output Contact, press ENTER (F4) .
3	<pre>ZR402G: Test DO1: 1 OPEN 2 CLOSE 3 EXIT ABORT ENTER</pre>	<div style="border: 1px solid black; width: 30px; height: 30px; display: flex; align-items: center; justify-content: center; margin: 0 auto;">STU 1</div>	Select " 1. OPEN ", then the Output Contact is "Open".
4	<pre>ZR402G: DO1 is OPEN Press OK ABORT OK</pre>	<div style="border: 1px solid black; width: 30px; height: 30px; display: flex; align-items: center; justify-content: center; margin: 0 auto;">F4</div> (OK)	Press OK (F4) .

F040301.EPS

4.4 Test Cal. DO

The following shows the procedures for checking the automatic calibration solenoid valve.

(Refer to Section 7.9, "Checking Contact I/O" in the ZR202G Instruction Manual.)

(Refer to Section 7.11, "Checking Contact I/O" in the ZR402G Instruction Manual.)

Call up "Test Cal. DO" display.

ZR202G

1.Device setup ---> 2.Diag / Service ---> 1.Test device ---> 7.Test Cal. DO

ZR402G

2.Diag / Service ---> 1.Test device ---> 7.Test Cal. DO

	Display	Operation	
1		 (OK)	Press OK (F4) .
2			Select the solenoid valve output to be checked. An example of selecting the valve for ZERO calibration gas is shown on the left. After selecting the valve, press ENTER (F4) .
3			When you select "2. ON", the solenoid valve for the zero calibration gas becomes active.
4		 (OK)	Press OK (F4) .

F040401.EPS

Revision Record

Manual Title : Model EXAxt ZR Series HART Protocol

Manual Number : IM 11M12A01-51E

Edition	Date	Remark (s)
1st	Sept. 2000	Newly published
