

General Specifications

Model PH20 and FU20
pH/Redox and Temperature sensor

The PH20 is nicknamed "Tempress" because of the patented compensation for changes in the process temperature and pressure. This simple mechanical feature makes the sensor more accurate, and gives it a longer lifetime. The compensation panels flex to accommodate changes in the avoiding large differential pressures across the diaphragm. This prevents most problems associated with the reference junction. Made in chemically resistant PVDF, this all-in-one sensor has elements to measure pH, ORP and temperature. The reference system is Silver/Silver Chloride, with a double junction and a gelled electrolyte to combat pollution. The Platinum Redox electrode doubles as a solution ground, essential for uncompromising accuracy, and for sensor diagnostic measurements.

The FU20 combination sensors show how Yokogawa applies the motto "Simply the Best" to sensor technology. The wide body sensors (26 mm diameter) hold four separate elements in one unbreakable PPS 40GF (Ryton™) body. Installation is simple with the integrated industrial 3/4" tapered thread. The large volume gelled electrolyte and the double junction reference system slows down depletion and poisoning therefore extending the lifetime. The system is targeted at those applications where simplicity will result in accurate and reliable pH- or redox measurements. This means that in 90% of the know applications this sensor will be an excellent choice.

Features

- Simultaneous pH- and ORP measurement
- Integral Pt1000 temperature element for enhanced accuracy
- Available with VP connector
- Double junction and long diffusional path for reference pollution resistance
- Extended life time by large volume of polymerized electrolyte and porous PTFE diaphragm
- Solid Glass/Platinum electrode for solution ground or ORP measurement
- Simple maintenance by comprehensive design
- Direct in-line, immersion or off-line installation
- Calibration certificate delivered with each sensor



System Configuration

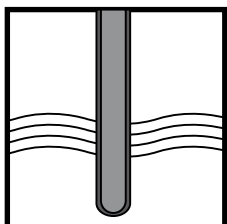

Sensors

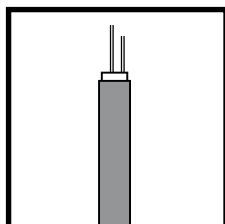

Cables

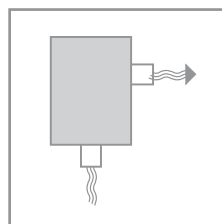

Fittings

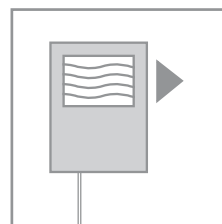

Transmitters

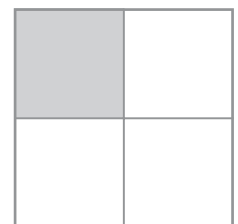

Accessories

General Specifications PH20

Measuring elements : pH glass electrode and Silver /Silver chloride reference system.
: Platinum electrode and Pt1000 temperature sensor.

Construction materials

Body : PVDF
Earthing pin : Solid platinum/glass
O-ring : Viton
Reference junction : Porous PTFE
Cable : Coaxial with 4 extra leads
Sheetmaterial : Thermoplastic rubber

Functional specifications (at 25°C)

Isothermal point : pH 7
Reference system : Ag/AgCl with saturated KCl
Glass impedance : 200 M Ω (nominal), G-glass
Junction resistance : 1 to 10 k Ω
Temperature element : Pt1000 to IEC 751
Asymmetry potential : < 15 mV
Slope : > 96 % (of theoretical value)

Dynamic specifications (at 25°C)

Response time pH step (7 to 4)
: < 10 sec for 90%
Response time temp. step (10°C)
: < 3 min for 90 %
Stabilisation time (0.02 pH/10 s)
: < 1 minute

Operating range

pH : 0 - 14*
Temperature : -10 to 105°C (14 to 212 °F)
Pressure : 0 to 10 bar (0 to 142 PSIG)
Conductivity : > 50 μ S/cm
Storage temperature : -30 to 50°C (-22 to 122 °F)

The erratic trend of the standard sensor shows the progressive contamination of its reference junction. The graph indicates between 0.1 to 0.4 pH error with the conventional sensor while the readings from the PH20 are extremely stable.

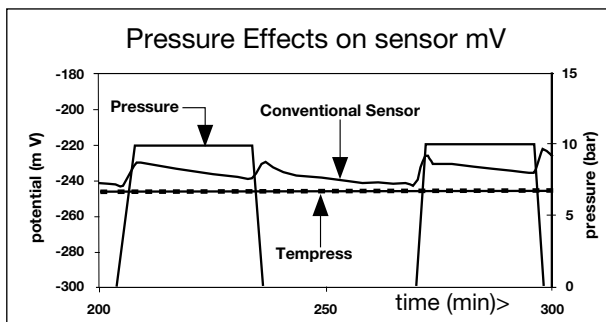

General Specifications FU20

Measuring elements : pH glass electrode and silver chloride reference system.
Platinum electrode and Pt1000 temperature sensor.

Construction materials

Body : Ryton R4™ (PPS 40GF) with glass filling
Earthing pin : Solid platinum
O-ring : None
Reference junction : Porous PTFE
Cable : Coaxial with 4 extra leads
Sheetmaterial : Thermoplastic rubber

Functional specifications (at 25°C)

Isothermal point : pH 7
Reference system : Ag/AgCl with saturated KCl
Glass impedance : 350M Ω , G-glass
- Dome shape : 750M Ω , G-glass
Junction resistance : 0.5 to 5 k Ω
Temperature element : Pt1000 to IEC 751
Asymmetry potential : < 15 mV
Slope : > 96 % (of theoretical value)

Dynamic specifications (at 25°C)

Response time pH step (7 to 4)
: < 15 sec for 90%
Response time temp step (10°C)
: < 3 min for 90%
Stabilisation time (0.02 pH/10 s)
: < 2 minutes

Operating range

pH : 0 - 14*
Temperature : -10 to 105°C (14 to 212 °F)
Pressure : 0 to 10 bar (0 to 142 PSIG)
Conductivity : > 50 μ S/cm
Storage temperature : -30 to 50°C (-22 to 122 °F)

* The pH range at room temperature is 0 -14 pH, but at high temperatures the lifetime will be seriously shortened outside 2 - 12 pH range.

Dimensions

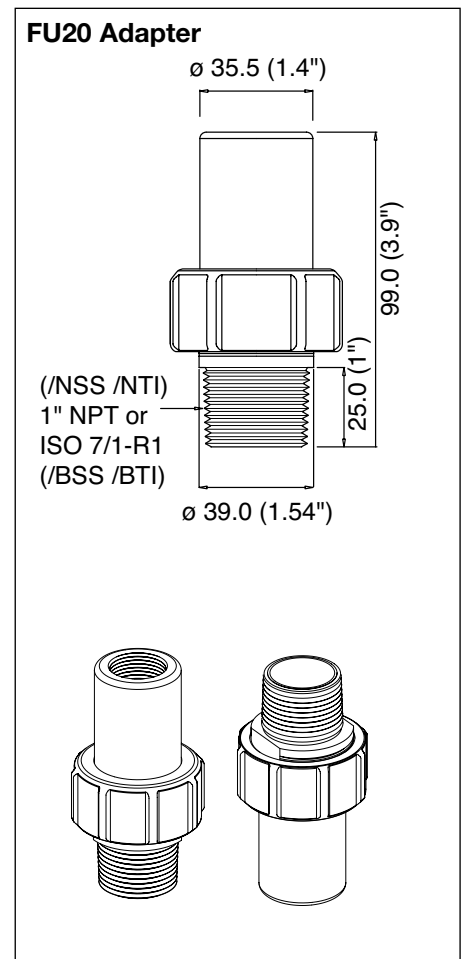
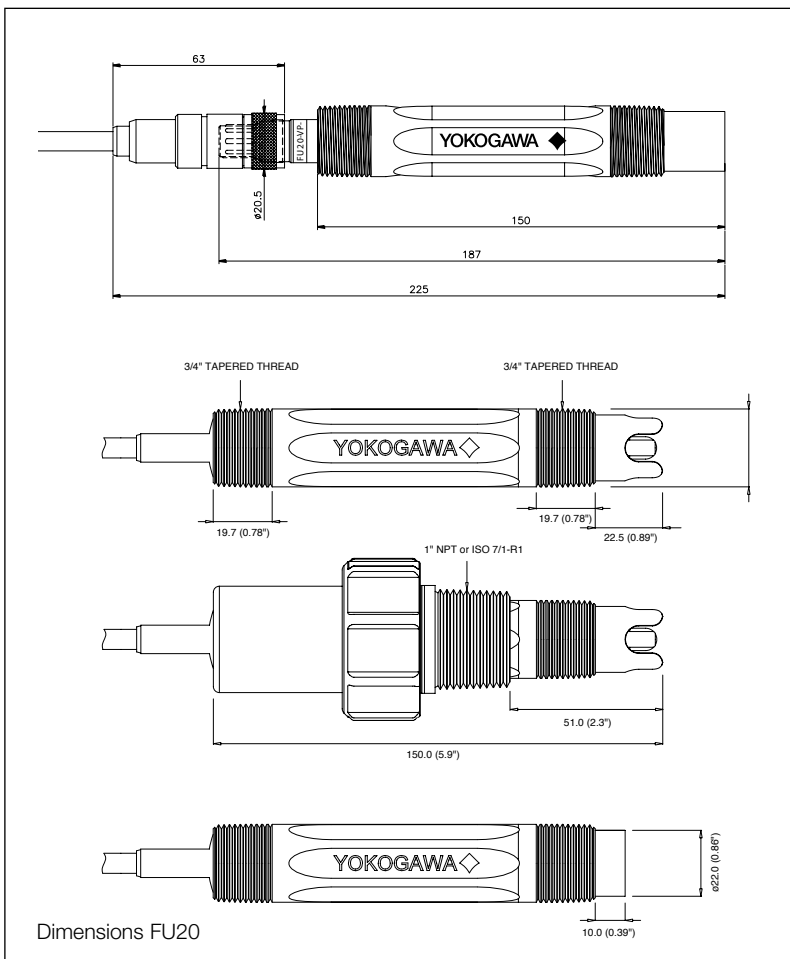
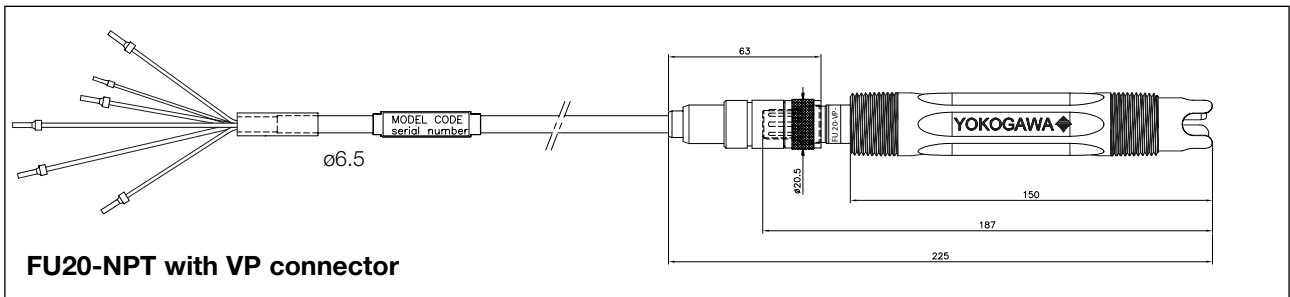
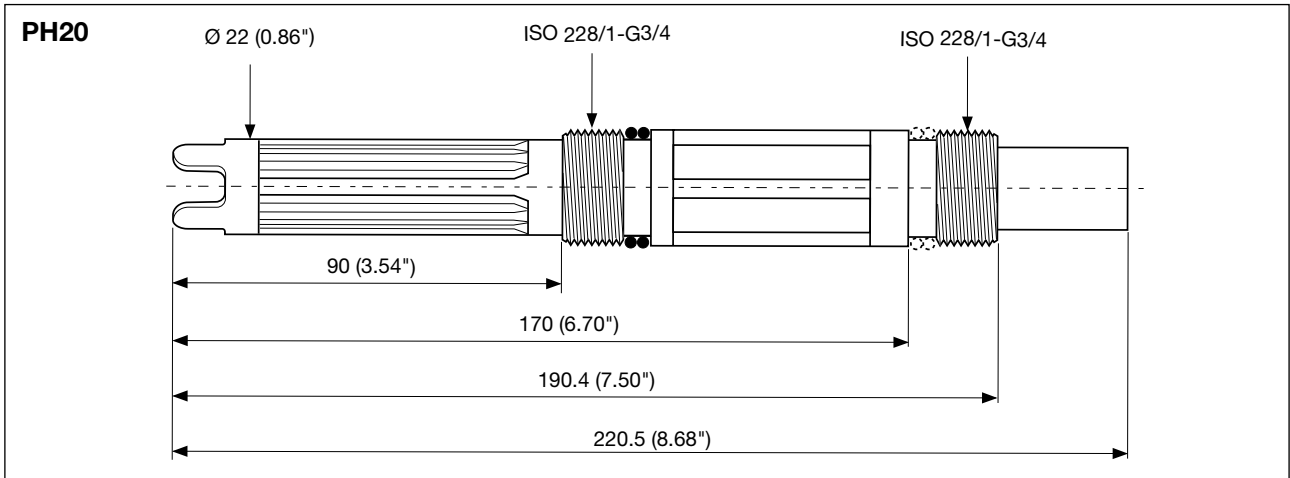

Installation examples using the PH20 adapter range

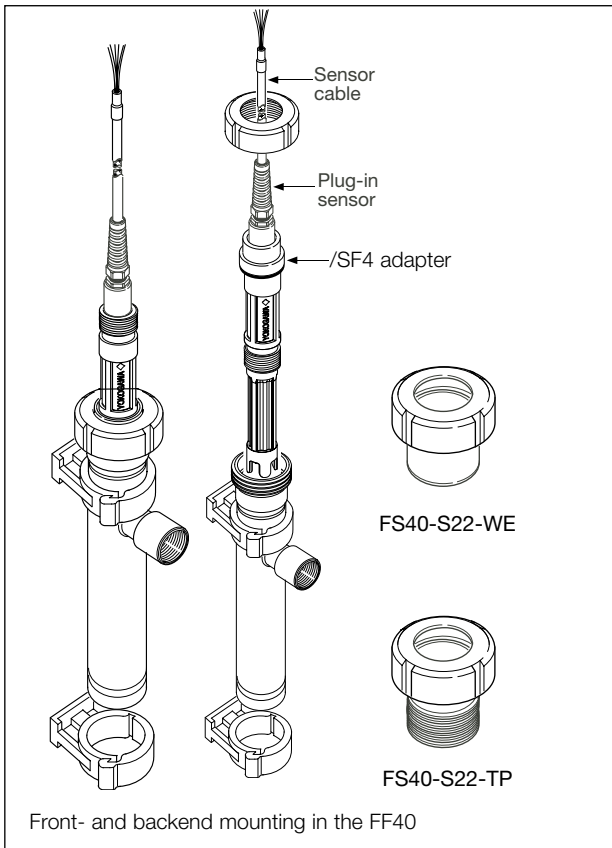

Using the /SF4 adapter, the PH 20 can be mounted in the standard range of conductivity flow fitting (FF40...), the immersion fittings (FD40...) and sub-assemblies (FS40...). The adapter can be mounted on the front thread, or the back thread dependent on the required insertion depth.

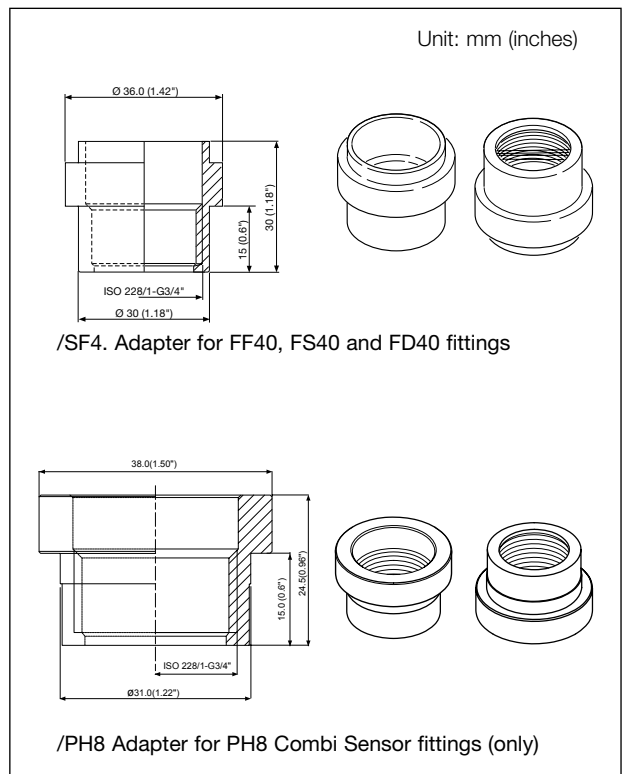
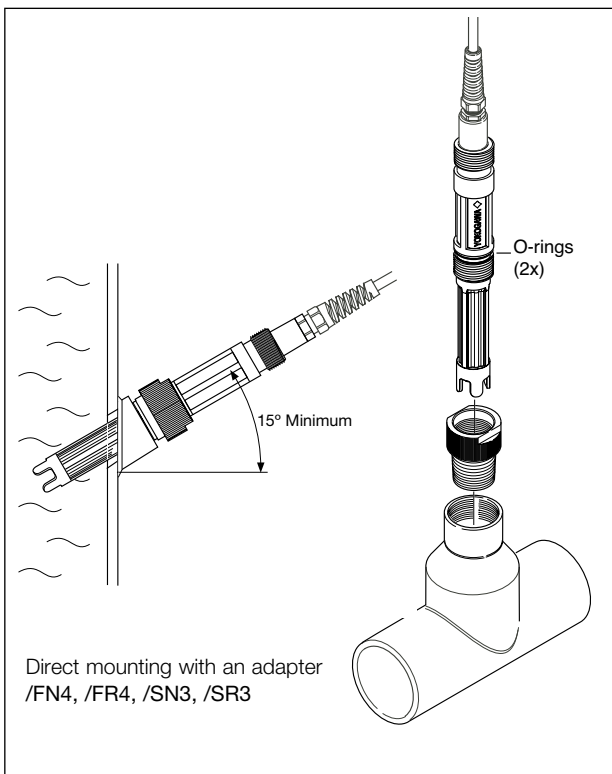
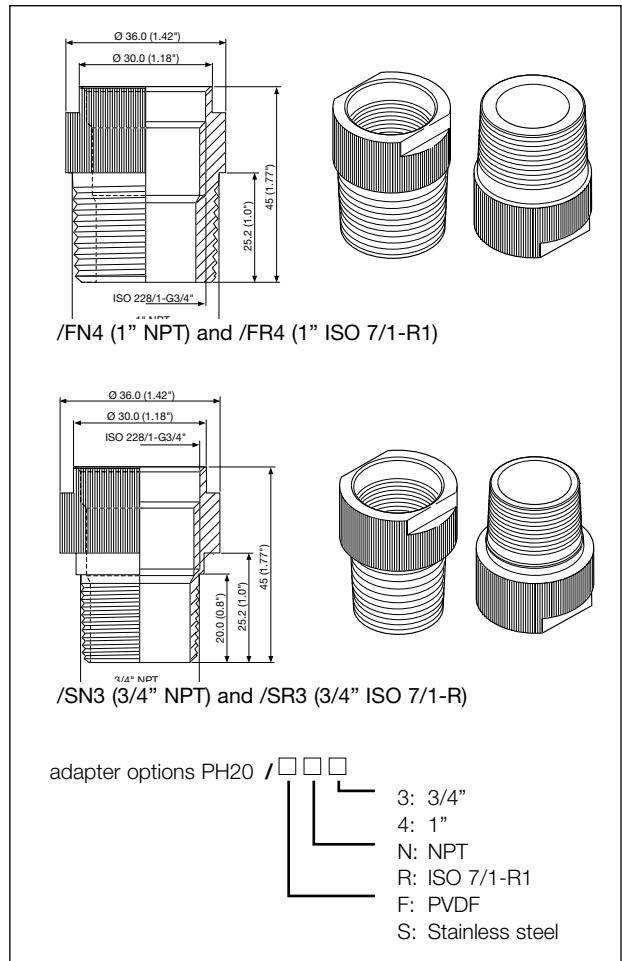

Installation examples using the FU20 adapter range

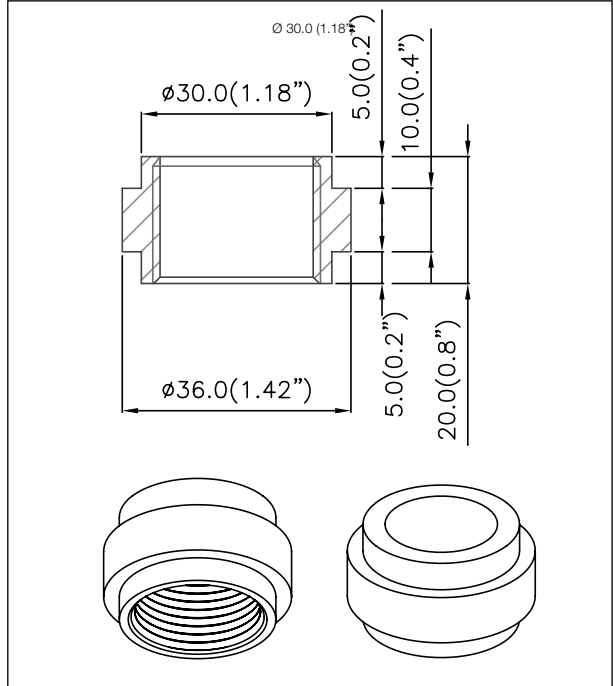
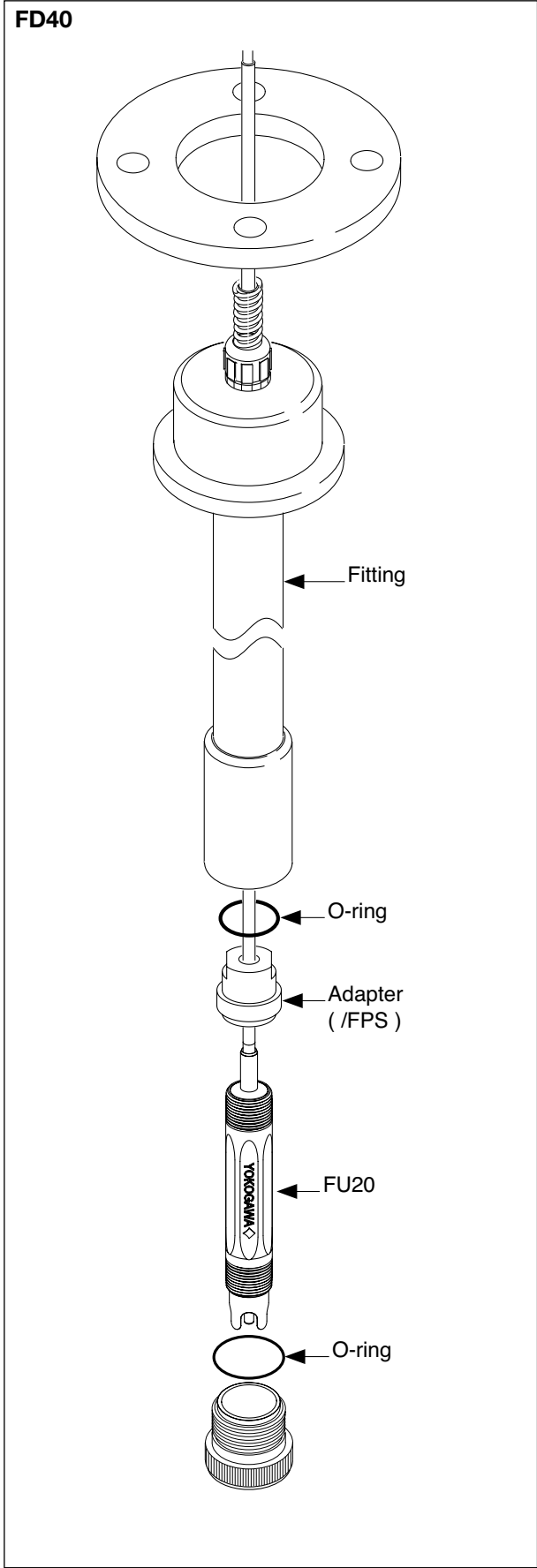

Dimensions Ryton adapter for FF40, FS40 and FD40 fittings (/FPS or K1523DD)

Note: old part K1523DC is not compatible with VP connector.

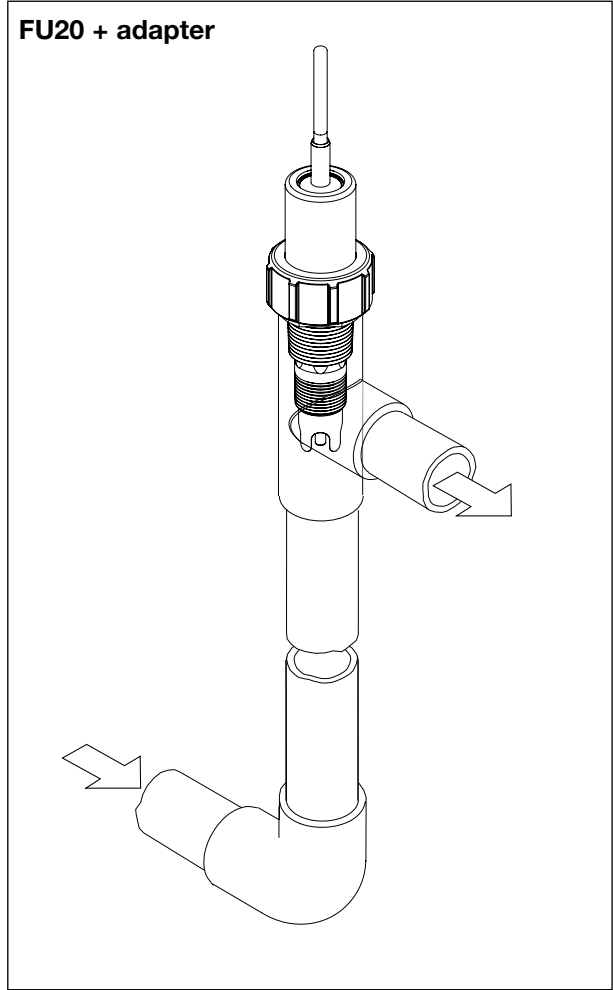

Model and Suffix codes

Model Code	Suffix code	Option	Description
PH20			4-in-1 pH sensor
Material	-F		PVDF
Membrane	-G		Dome shaped
Cable length	-02 -05 -10 -20 -30		2 meter 5 meter 10 meter 20 meter 30 meter
Temp. element	-T1		Pt1000
	-N -A		Always -N -A
Options*		/SN3 /SR3 /FN4 /FR4 /PH8 /SF4 /HCNF	Stainless steel 3/4" NPT adapter (316L) Stainless steel 3/4" R adapter (316L) PVDF 1" NPT adapter PVDF 1" R adapter Adapter for PH8 combi sensor fittings (only) Stainless steel adapter for FF40, FS40 and FD40 fittings Hastelloy cleaning system

* **Note:** Option /Q: Quality Inspection certificate is always included with the product.

Model Code	Suffix code	Option	Description
FU20			Wide body sensor
	-VP		Variopin connector
Cable length	-03 -05 -10 -20		3 meter 5 meter 10 meter 20 meter
Temp. element	-T1		Pt1000
Model	-NPT -FSM		Dome shape model Flat surface model
Options*		/HCNF /FPS /NSS /NTI /BSS /BTI	Hastelloy cleaning system Adapter F*40 from noryl 1" NPT adapter, SS (316L) 1" NPT adapter, Titanium 1" BSP adapter, SS (316L) 1" BSP adapter, Titanium

* **Note:** Option /Q: Quality Inspection certificate is always included with the product.

Model	Suffix Code	Description
WU10		Sensor cable
Connector type	-V	Variopin
Cable type	-S	Single Coax
Cable length	-02 -05 -10 -15 -20	2 meters 5 meters 10 meters 15 meters 20 meters

Spare parts PH20, FU20 and cleaning system

Part no.	Description
K1500EK	O-rings viton 6.07x1.78 (5x2)
K1500ER	O-ring set Viton FF20-S22
K1511DP	O-rings viton 21.9x2.62 (5x2)
K1511DQ	O-rings EPDM 21.9x2.62 (5x2)
K1547PC	/FN4 for PH20
K1547PD	/FR4 for PH20
K1547PE	/PH8 for PH20
K1547PG	Nozzle and mounting HCN4
K1547PP	Spare Part EPDM spraying valves
K1547QA	/SN3 for PH20
K1547QB	/SR3 for PH20
K1547QF	/SF4 for PH20
K1500FR	O-rings Viton 29.82x2.62 (5)
K1500FS	O-rings EPDM 29.82x2.62 (5)
K1500FT	O-rings Silicon, 29.82x2.62 (5)
K1520ZD	Mounting nut for PS20
K1523DD	/FPS, FU20-mounting in F*40
K1547PK	Adapter 1" NPT, SS 316 for FU20
K1547PL	Adapter 1" BSP, SS 316 for FU20
K1547PM	Adapter 1" NPT, Ti for FU20
K1547PN	Adapter 1" BSP, Ti for FU20
K1547PJ	Hast. cleaning unit HCNF
K1547PF	Nozzle and mounting HCN2/3/F

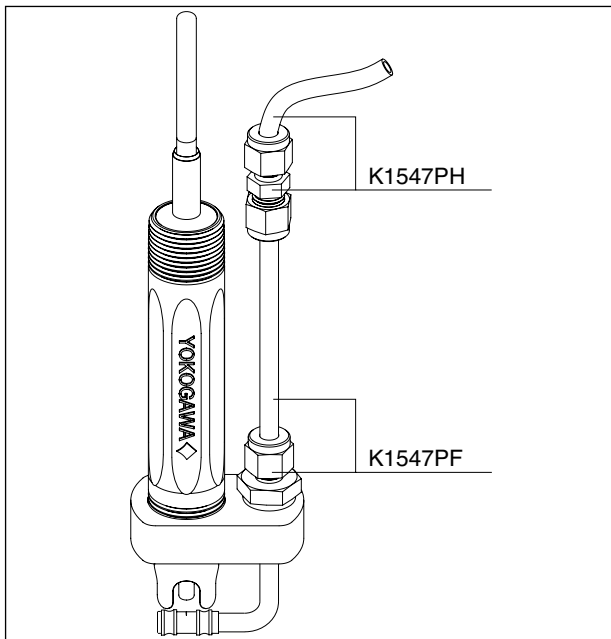

Option /HCNF

Accessories

Buffer powder

6C231	Buffer powder pH 1.68 ; IEC 60746-2
6C232	Buffer powder pH 4.01 ; IEC 60746-2
6C236	Buffer powder pH 9.18 ; IEC 60746-2
6C237	Buffer powder pH 6.87 ; IEC 60746-2

Connection equipment

BA10	Junction box for pH extension cables
WF10-xxx-F	pH signal cable with terminated ends. Specify length in whole meters

Cleaning system for FU20 & PH20

Some applications require frequent cleaning of the electrode. For these applications Yokogawa designed a chemical cleaning system that can either be used in the Yokogawa fitting range (HCN2, HCN3 or HCN4) or as back-end mounting option for the PH20 and FU20. The /HCNF option comes with a hastelloy cleaning nozzle, Stainless steel mounting (and ferrules) sets and a nylon tube of 10 meters.

Wiring of the PH20 / FU20

Conventional pH (& ORP) wiring

Connect the PH20 or FU20 to the EXA or EXAxt PH analyzer as shown. With this configuration, it is possible to measure ORP (or rH) at the same time (Refer to the EXA or EXAxt manual for appropriate impedance jumper and Service Code settings).

pH (& ORP) WIRING DIAGRAM

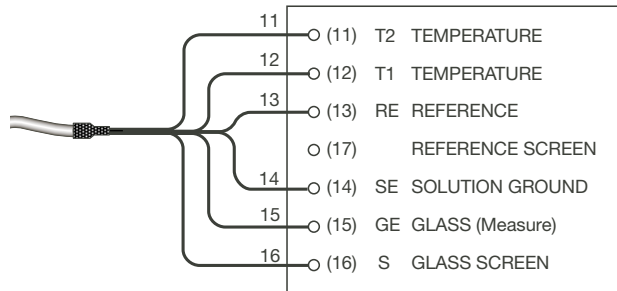

Wiring for ORP measurement with normal reference

Connect the PH20 or FU20 to the EXA PH analyzer as shown. Refer to the EXA manual for appropriate impedance jumper and Service Code settings.

ORP WIRING DIAGRAM with normal reference

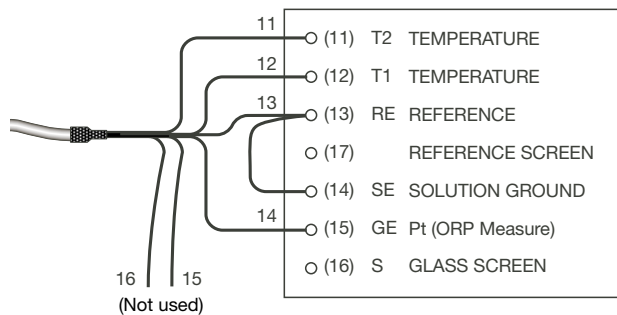

Wiring for ORP measurement with pH reference

Connect the PH20 or FU20 to the EXA Glass PH analyzer as shown. Refer to the EXA manual for appropriate impedance jumper and Service Code settings.

ORP WIRING DIAGRAM with pH sensor as reference

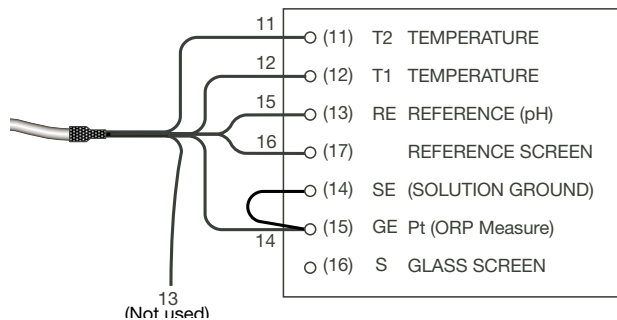

YOKOGAWA HEADQUARTERS
9-32, Nakacho 2-chome,
Musashinoshi
Tokyo 180
Japan
Tel. (81)-422-52-5535
Fax (81)-422-55-1202
www.yokogawa.com

YOKOGAWA CORPORATION OF AMERICA
2 Dart Road
Newnan GA 30265
United States
Tel. (1)-770-253-7000
Fax (1)-770-251-2088
www.yokogawa.com/us

Yokogawa has an extensive sales and distribution network. Please refer to the European website (www.yokogawa.com/eu) to contact your nearest representative.

YOKOGAWA EUROPE B.V.
Databankweg 20
3821 AL AMERSFOORT
The Netherlands
Tel. +31-33-4641 611
Fax +31-33-4641 610
www.yokogawa.com/eu

YOKOGAWA ELECTRIC ASIA Pte. Ltd.
5 Bedok South Road
Singapore 469270
Singapore
Tel. (65)-241-9933
Fax (65)-241-2606
www.yokogawa.com/sg



YOKOGAWA ◆