

# General Specifications

Junction box and Connecting cable  
Model BA10 and WF10

pH/ORP

Between measuring plant and control room, especially when the distance between these places is greater than the length of the standard appropriate electrode cables, the connecting equipment can be an expedient method for connecting sensor cables to a measuring instrument.

The equipment includes:

1. A junction box.
2. Special purpose connecting cable.

The items are available for common as well as for intrinsically safe applications.



## SYSTEM CONFIGURATION

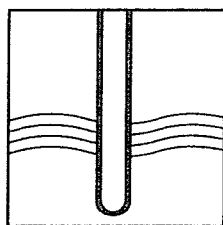

Sensors

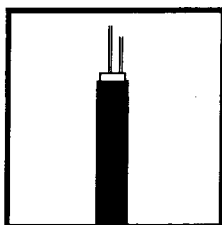

Cables

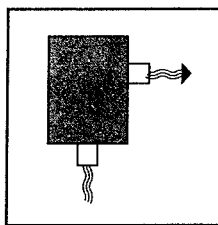

Fittings

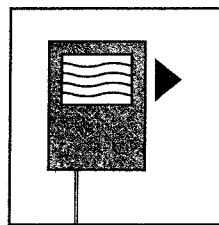

Transmitters

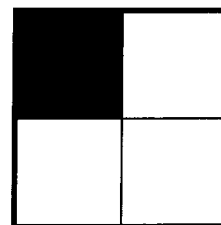

Accessories

### 1. JUNCTION BOX, type BA10

The junction box is an expedient method for connecting sensor cables to a measuring instrument.

**Note**

The special purpose cable, type WF10 should be used to interconnect the junction box and the measuring instrument. To have optimum measuring results the length of this cable may be max. 100 m.

**SPECIFICATIONS**

- Material** : Cast aluminium with chemically resistant lacquer
- Rain- and dust protection** : Meets IP 65
- Terminals** : Wires up to 6 mm<sup>2</sup>
- Cable entries\*** : 2 Holes with screw thread for 1 hose connection and a gland PG 16 or 2 glands PG 16
- Colour terminal block**
  - Normal use : Brown
  - IS Design : Blue
- Weight** : Ca. 2 kg.
- Dimensions** : See dimensional drawing
- Fixing** : 140 x 110 mm (indicated on reverse side of the box)

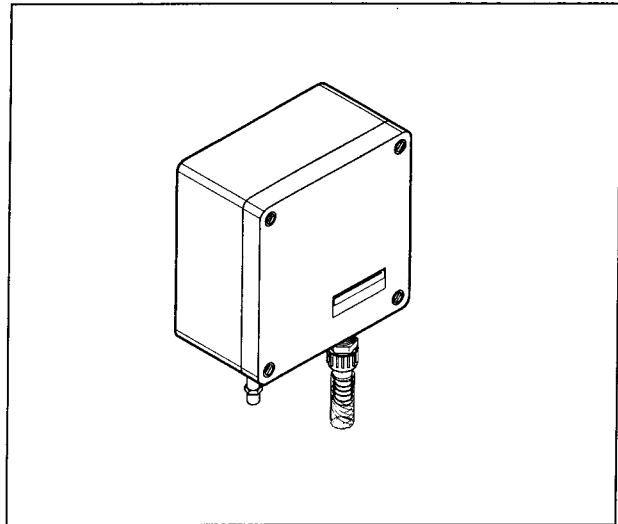

**Junction box**

**ORDERING INSTRUCTIONS**

Type	Description
BA10	For normal use

\* As delivered the box includes a plastic pocket with 2 glands PG 16, a hose connection for a 19 mm I/D protection hose and a grommet for watertight cable input in a gland (3 electrode cables and the liquid earth cable).

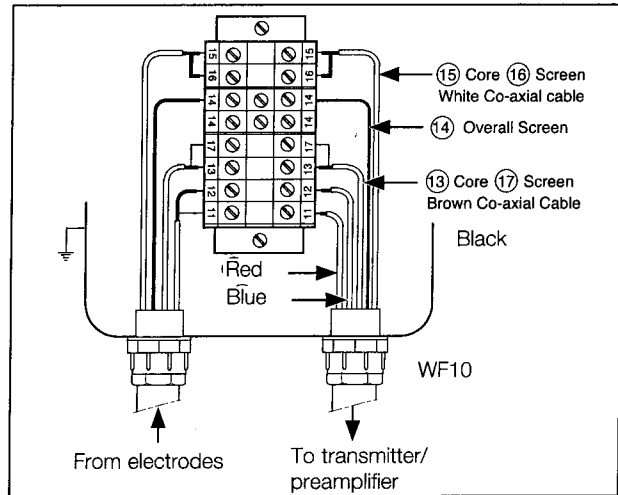

**Connection diagram**

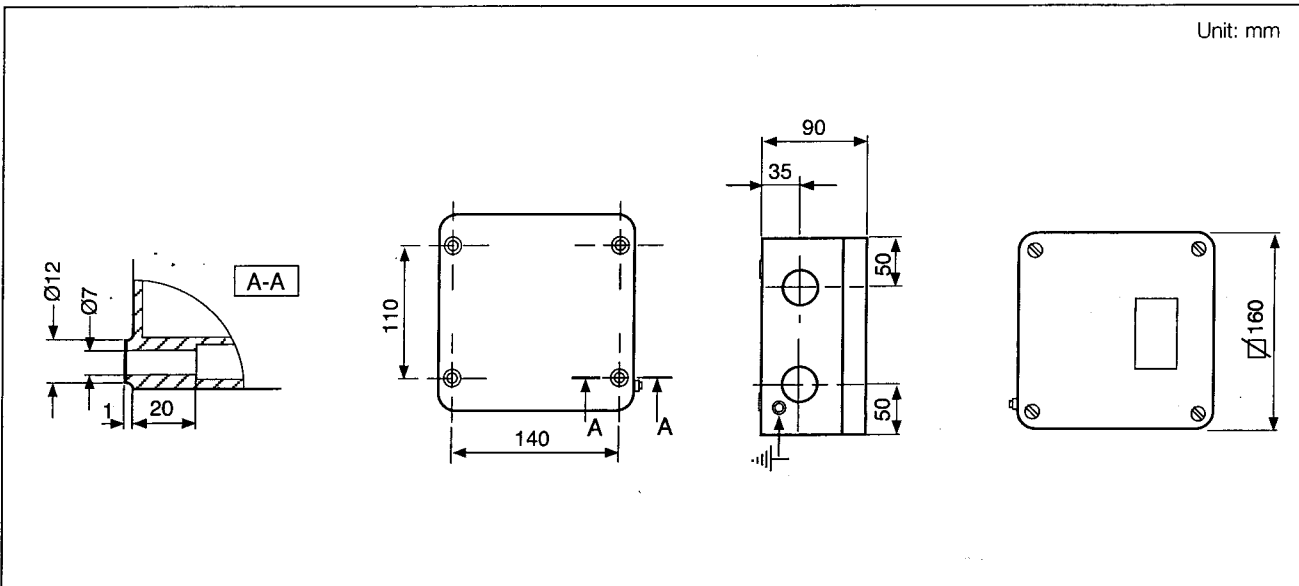

Unit: mm

**Dimensions/Fixing**

## 2. CONNECTING CABLE, type WF10

This cable satisfies the high requirements of insulating resistance and screening. It suits the application of signal transmission representing low voltage and high impedance level. The cable is used to interconnect junction box and measuring instrument.

**Note:**

Long cable lengths add resistance and capacitance to the measuring loop.

These values are specified below.

The maximum values for cable length, cable capacity that are specified in the Instruction Manual of the analyzer may not be exceeded. The resistance may introduce a measuring error, especially when using a 100 Ohm RTD.

Normally the analyzer can be calibrated for this error.

### SPECIFICATIONS

- Max. temperature** : 110 °C
- Material** : Thermoplastic Rubber (T.P.R.)
- Bending radius**
  - Permanent : > 83 mm
  - Frequently : > 125 mm
- Diameter** : 8.5 mm
- Colour** : Black

**CABLE A/B**

- Capacitance between core and screen** : max. 120 pF/m
- Insulation resistance between core and screen** : min. 15 x 10<sup>14</sup> Ohm. m
- Resistance** : ca. 80 Ohm/km
- Dielectric** : T.P. Rubber
- Jacket A** : Brown
- Jacket B** : White

**CABLE C/D**

- Resistance** : ca. 35 Ohm/km
- Jacket C** : T.P. Rubber (Red)
- Jacket D** : T.P. Rubber (Blue)

- CABLE E** : Overall shield

### ORDERING INSTRUCTIONS

**Model and Suffix code**

Model	Suffix code	Description
WF10	.....	Connecting cable
Cable length	- □ □ □ .....	Length in meters between 1 and 200
	-F .....	Finished
	-N .....	Not finished

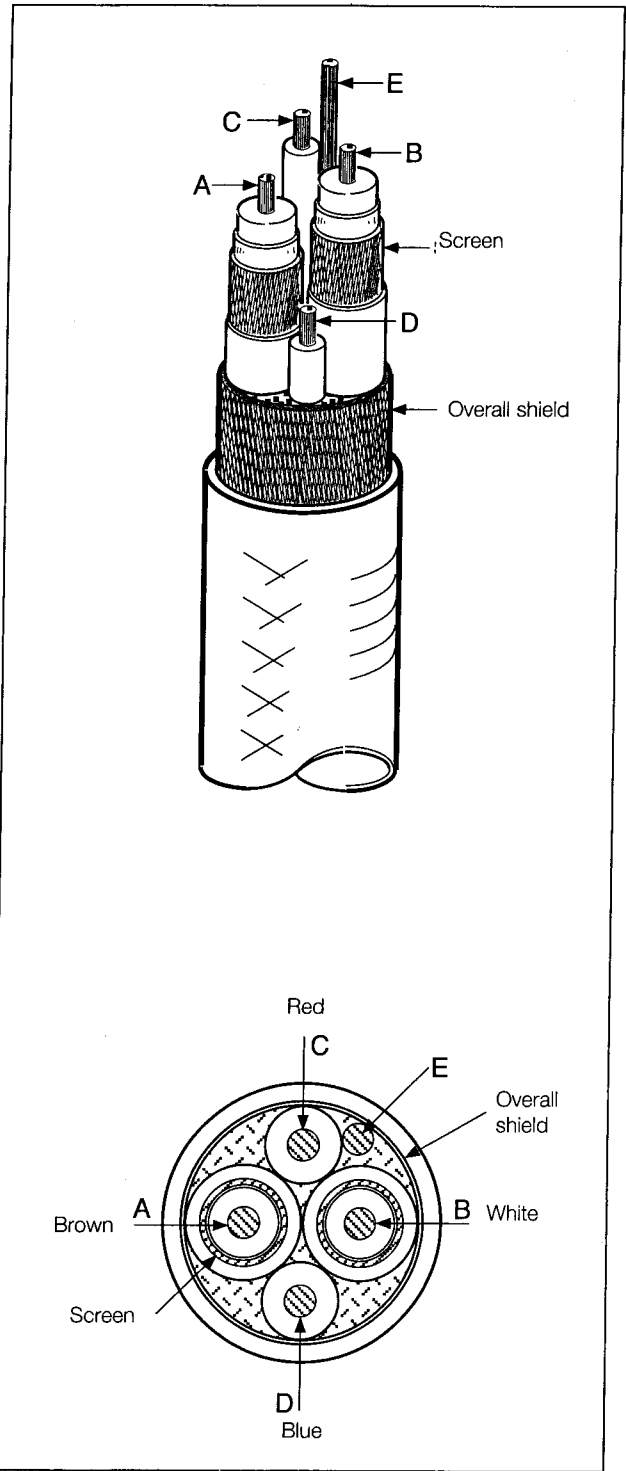

**Connecting cable WF10**

## ACCESSORIES AND PARTS

Type	Description
WU20-PC01	COAX-cable for single electrode (1 m)
WU20-PC02	COAX-cable for single electrode (2 m)
WU20-PC05	COAX-cable for single electrode (5,5 m)
WU20-PC10	COAX-cable for single electrode (10 m)
WU20-PC15	COAX-cable for single electrode (15 m)
WU20-PC20	COAX-cable for single electrode (20 m)
WU20-PC25	COAX-cable for single electrode (25 m)
WU20-LT01	TRIAX-cable for combined electrode (1 m)
WU20-LT02	TRIAX-cable for combined electrode (2 m)
WU20-LT05	TRIAX-cable for combined electrode (5,5 m)
WU20-LT10	TRIAX-cable for combined electrode (10 m)
WU20-LT15	TRIAX-cable for combined electrode (15 m)
WU20-LT20	TRIAX-cable for combined electrode (20 m)
WU20-LT25	TRIAX-cable for combined electrode (25 m)
82895002	Liquid earth cable (10 m)
K1500BX	Grommet for watertight cable input in PG 16 gland (3 electrode cables and liquid earth cable)
K1520NC	Protection hose (I/D 19 mm), per m

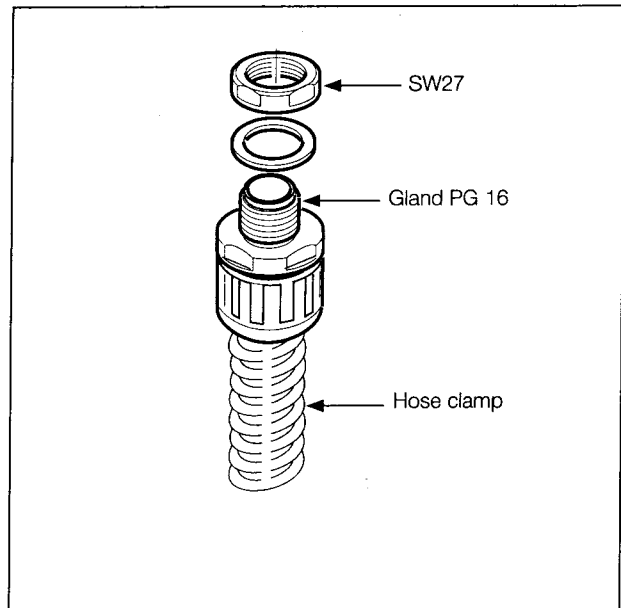

Hose connection

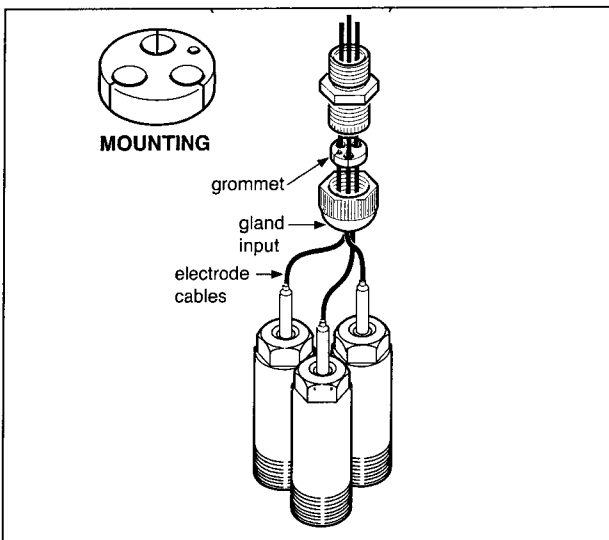

Application

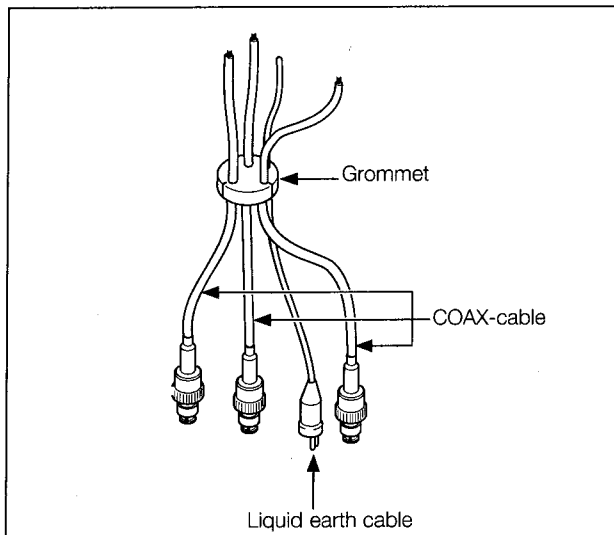

Cable

**YOKOGAWA HEADQUARTERS**  
 9-32, Nakacho 2-chome,  
 Musashinoshi  
 Tokyo 180  
 Japan  
 Tel. (81)-422-52-5535  
 Fax (81)-422-55-1202  
 E-mail: webinfo@mls.yokogawa.co.jp  
 www.yokogawa.com

**YOKOGAWA CORPORATION OF AMERICA**  
 2 Dart Road  
 Newnan GA 30265  
 United States  
 Tel. (1)-770-253-7000  
 Fax (1)-770-251-2088  
 E-mail: info@yca.com  
 www.yca.com

**YOKOGAWA EUROPE B.V.**  
 Databankweg 20  
 3821 AL AMERSFOORT  
 The Netherlands  
 Tel. +31-33-4641 611  
 Fax +31-33-4641 610  
 E-mail: info@yokogawa.nl  
 www.yokogawa-europe.com

**YOKOGAWA ELECTRIC ASIA Pte. Ltd.**  
 5 Bedok South Road  
 Singapore 469270  
 Singapore  
 Tel. (65)-241-9933  
 Fax (65)-241-2606  
 E-mail: webinfo@yas.com.sg  
 www.yokogawa.com.sg

Yokogawa has an extensive sales and distribution network. Please refer to the European web-site ([www.yokogawa-europe.com](http://www.yokogawa-europe.com)) to contact your nearest representative.



**YOKOGAWA** ◆